



Model created in COMSOL Multiphysics 6.4

Rat-Race Coupler

Introduction

A 180° Ring Hybrid (Rat-Race Coupler) is a four-port network with 180° phase difference between two ports. It is easier to manufacture this type of microstrip line component compared to a waveguide 180° hybrid junction, a so-called magic-T. The objective of this example is to compute the S-parameters and to observe the matching, isolation, and coupling around the operating frequency.

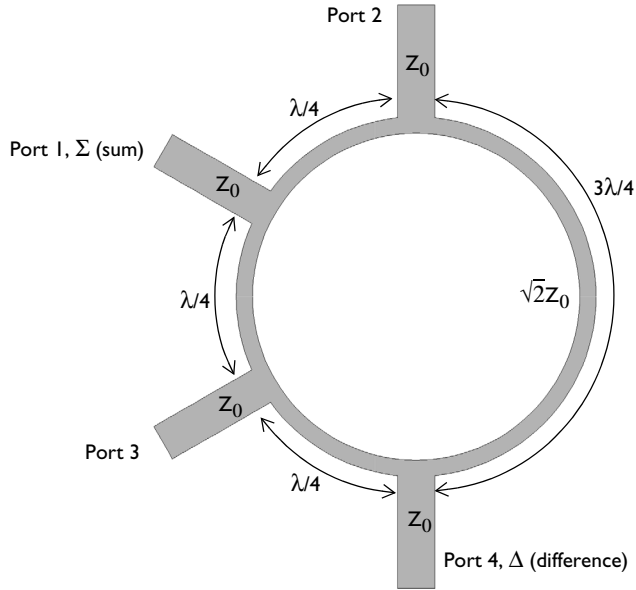

Figure 1: The geometry of rat-race coupler consists of four ports and a ring strip.

Model Definition

The form of the rat race coupler is shown schematically in [Figure 1](#). The layout design is based upon [Ref. 1](#), and is tuned to operate at 3 GHz. The design is realized as microstrip lines patterned onto a 0.060 inch dielectric substrate. The microstrip lines are modeled as perfect electric conductor (PEC) surfaces, and another PEC surface on the bottom of the dielectric substrate acts as a ground plane. The entire modeling domain is bounded by PEC boundaries that represent the device packaging. The four ports are modeled as small

rectangular faces that bridge the gap between the PEC face that represents the ground plane, and the PEC faces that represent the microstrip line at each port.

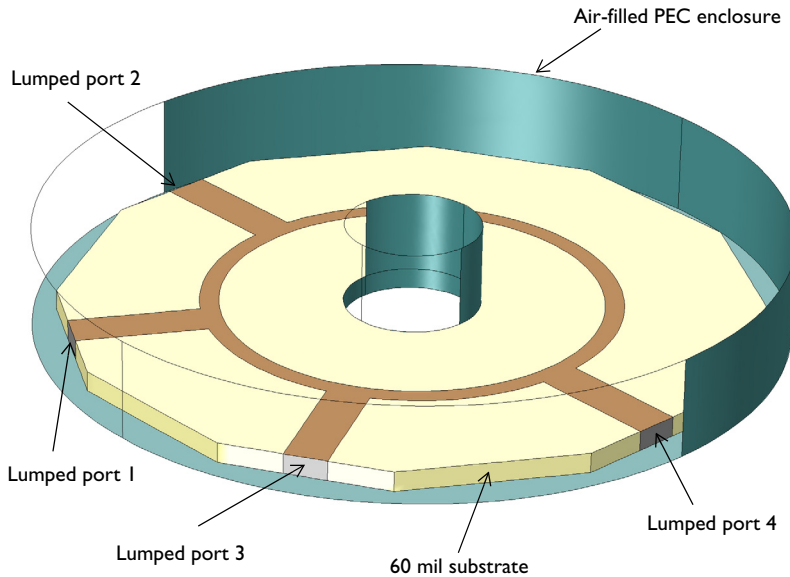

Figure 2: The model of the rat-race coupler. Some exterior faces are removed for visualization.

The model is shown in [Figure 2](#). A small air domain bounded by PEC surface around the device is also modeled. The PEC enclosure representing a metallic housing works as a cylindrical cavity. A metallic cylindrical post in the middle of the cavity is added to remove possible cavity resonances in the simulation frequency sweep range. The model is meshed using a tetrahedral mesh. A good rule of thumb is to use approximately five elements per wavelength in each material.

Results and Discussion

There are two paths from a source port to an observation port. The response at the observation port can be estimated from the difference between two paths. [Figure 3](#) shows the computed S-parameters when the port 1 is excited. At a frequency of 3 GHz, the signal is evenly split between the two output ports (lumped port 2 and 3) with a very small

amount of losses. The input signal is barely coupled to the isolation port (lumped port 4) where S_{41} is less than -30 dB at 3 GHz.

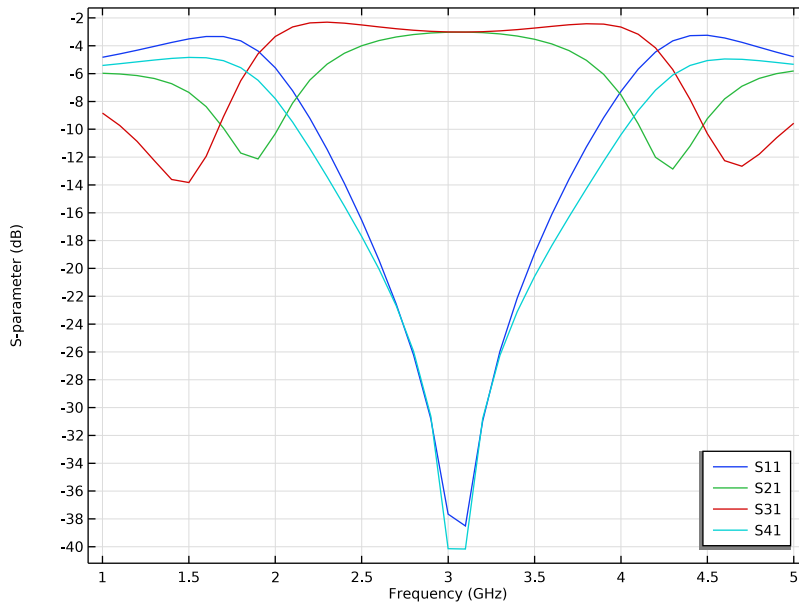

Figure 3: The frequency response of the branch line coupler shows good input matching (S_{11}) and isolation (S_{41}) around 3 GHz. The coupled signal at two output ports (S_{21} and S_{31}) is about -3 dB at 3 GHz.

Next, the port 2 and 3 are excited evenly at the same time and the voltages at the port 1 (sum port) and port 4 (difference port) are observed. At a frequency of 3 GHz, the voltage at the port 1 is 3 dB higher than the voltage at each input port and almost zero response

is shown at the port 4 where two input signals are canceled out. The sum and difference port responses are plotted in [Figure 4](#).

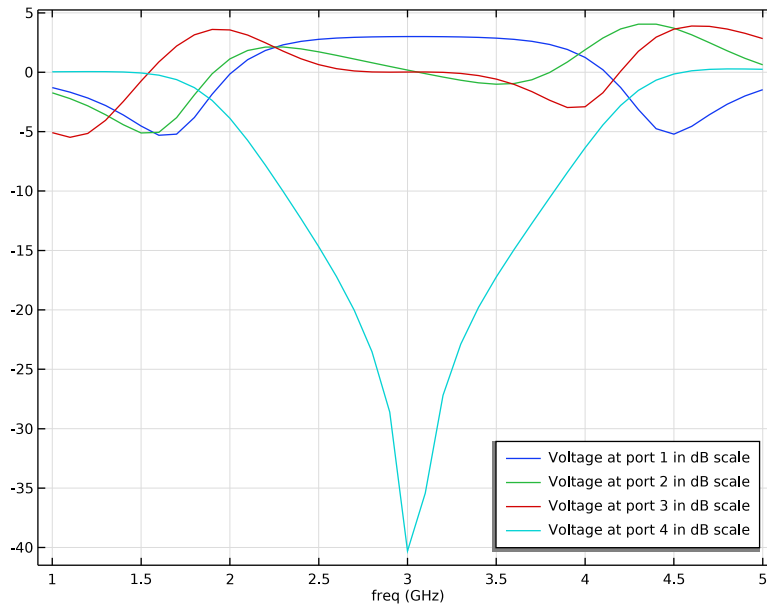

Figure 4: The rat race coupler works as a power combiner, too. The responses at the sum and difference ports at 3 GHz are as expected.

References

1. D.M. Pozar, *Microwave Engineering*, John Wiley & Sons, 1998.
 2. R.E. Collin, *Foundation of Microwave Engineering*, McGraw Hill, 1992.
-

Application Library path: RF_Module/Couplers_and_Power_Dividers/
rat_race_coupler



Modeling Instructions

From the **File** menu, choose **New**.

NEW

In the **New** window, click  **Model Wizard**.

MODEL WIZARD

- 1 In the **Model Wizard** window, click  **3D**.
- 2 In the **Select Physics** tree, select **Radio Frequency > Electromagnetic Waves, Frequency Domain (emw)**.
- 3 Click **Add**.
- 4 Click  **Study**.
- 5 In the **Select Study** tree, select **General Studies > Frequency Domain**.
- 6 Click  **Done**.

STUDY I

Step 1: Frequency Domain

Define the study frequency ahead of performing any frequency-dependent operation such as building mesh. The physics-controlled mesh uses the highest frequency value in the specified range.

- 1 In the **Model Builder** window, under **Study I** click **Step 1: Frequency Domain**.
- 2 In the **Settings** window for **Frequency Domain**, locate the **Study Settings** section.
- 3 Click  **Range**.
- 4 In the **Range** dialog, type 1 [GHz] in the **Start** text field.
- 5 In the **Stop** text field, type 5 [GHz].
- 6 In the **Step** text field, type 100 [MHz].
- 7 Click **Replace**.

GLOBAL DEFINITIONS

Parameters I

- 1 In the **Model Builder** window, under **Global Definitions** click **Parameters I**.
- 2 In the **Settings** window for **Parameters**, locate the **Parameters** section.
- 3 Click  **Load from File**.
- 4 Browse to the model's Application Libraries folder and double-click the file `rat_race_coupler_parameters.txt`.
Here, `mil` refers to the unit milliinch.

GEOMETRY I

Click the  **Wireframe Rendering** button in the **Graphics** toolbar.

First, create two cylinders for the metallic housing.

Cylinder 1 (cyl1)



- 1 In the **Geometry** toolbar, click  **Cylinder**.
- 2 In the **Settings** window for **Cylinder**, locate the **Size and Shape** section.
- 3 In the **Radius** text field, type $r_{\text{subs}} \cdot 1.1$.
- 4 In the **Height** text field, type $d_{\text{subs}} \cdot 5$.

Cylinder 2 (cyl2)

- 1 In the **Geometry** toolbar, click  **Cylinder**.
- 2 In the **Settings** window for **Cylinder**, locate the **Size and Shape** section.
- 3 In the **Radius** text field, type 0.005 .
- 4 In the **Height** text field, type $d_{\text{subs}} \cdot 5$.

Add a work plane for the coupler layout.



Work Plane 1 (wp1)

- 1 In the **Geometry** toolbar, click  **Work Plane**.
Create two circles and subtract one from another for the ring strip.
- 2 In the **Settings** window for **Work Plane**, click  **Go to Plane Geometry**.

Work Plane 1 (wp1) > Plane Geometry

In the **Model Builder** window, click **Plane Geometry**.

Work Plane 1 (wp1) > Circle 1 (c1)

- 1 In the **Work Plane** toolbar, click  **Circle**.
- 2 Click the  **Zoom Extents** button in the **Graphics** toolbar.
- 3 In the **Settings** window for **Circle**, locate the **Size and Shape** section.
- 4 In the **Radius** text field, type $r_{\text{ring}} - w_{\text{ring}} / 2$.

Work Plane 1 (wp1) > Circle 2 (c2)

- 1 In the **Work Plane** toolbar, click  **Circle**.
- 2 In the **Settings** window for **Circle**, locate the **Size and Shape** section.
- 3 In the **Radius** text field, type $r_{\text{ring}} + w_{\text{ring}} / 2$.

Work Plane 1 (wp1) > Difference 1 (dif1)

- 1 In the **Work Plane** toolbar, click  **Booleans and Partitions** and choose **Difference**.



- 2 Select the object **c2** only.
- 3 In the **Settings** window for **Difference**, locate the **Difference** section.
- 4 Click to select the  **Activate Selection** toggle button for **Objects to subtract**.
- 5 Select the object **c1** only.

Add a rectangle for the feed line and generate the four feed lines by rotating the rectangle. Use the rotation angle range to create multiple objects.

Work Plane 1 (wp1) > Rectangle 1 (r1)

- 1 In the **Work Plane** toolbar, click  **Rectangle**.
- 2 In the **Settings** window for **Rectangle**, locate the **Size and Shape** section.
- 3 In the **Width** text field, type w_line .
- 4 In the **Height** text field, type l_line .
- 5 Locate the **Position** section. In the **xw** text field, type $-w_line/2$.
- 6 In the **yw** text field, type r_subs-l_line .

Work Plane 1 (wp1) > Rotate 1 (rot1)

- 1 In the **Work Plane** toolbar, click  **Transforms** and choose **Rotate**.
- 2 Select the object **r1** only.
- 3 In the **Settings** window for **Rotate**, locate the **Rotation** section.
- 4 Click  **Range**.
- 5 In the **Range** dialog, type 0 in the **Start** text field.
- 6 In the **Stop** text field, type 180.
- 7 In the **Step** text field, type 60.
- 8 Click **Replace**.

Create a union of all 2D objects on the work plane to remove the unnecessary interior boundaries.

Work Plane 1 (wp1) > Union 1 (uni1)

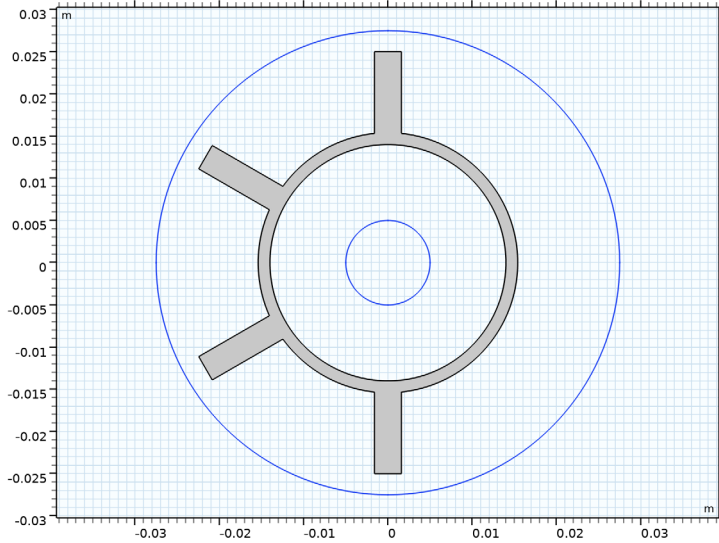

- 1 In the **Work Plane** toolbar, click  **Booleans and Partitions** and choose **Union**.
- 2 Click in the **Graphics** window and then press Ctrl+A to select all objects.
- 3 In the **Settings** window for **Union**, locate the **Union** section.
- 4 Clear the **Keep interior boundaries** checkbox.

5 Click  **Build Selected.**



Add a polygon for the substrate. This polygon covers only about 1/6 of the substrate area.

Work Plane 1 (wp1) > Polygon 1 (pol1)

- 1 In the **Work Plane** toolbar, click  **Polygon**.
- 2 Click the  **Zoom Extents** button in the **Graphics** toolbar.
- 3 In the **Settings** window for **Polygon**, locate the **Coordinates** section.
- 4 In the table, enter the following settings:

| xw (m) | yw (m) |
|--|---|
| 0 | 0 |
| x1 | y1 |
| -x1 | y1 |
| $-y1 \cdot \sin(\pi/3) + x1 \cdot \cos(\pi/3)$ | $y1 \cdot \cos(\pi/3) + x1 \cdot \sin(\pi/3)$ |
| $-y1 \cdot \sin(\pi/3) - x1 \cdot \cos(\pi/3)$ | $y1 \cdot \cos(\pi/3) - x1 \cdot \sin(\pi/3)$ |

5 Click  **Build Selected.**

Complete the substrate layout by rotating the polygon.



Work Plane 1 (wp1) > Rotate 2 (rot2)

- 1 In the **Work Plane** toolbar, click  **Transforms** and choose **Rotate**.
- 2 Select the object **pol1** only.

- 3 In the **Settings** window for **Rotate**, locate the **Rotation** section.
- 4 Click  **Range**.
- 5 In the **Range** dialog, type 0 in the **Start** text field.
- 6 In the **Stop** text field, type 300.
- 7 In the **Step** text field, type 60.
- 8 Click **Replace**.

Create a union of the polygon pieces to remove the unnecessary interior boundaries.

Work Plane 1 (wp1) > Union 2 (uni2)

- 1 In the **Work Plane** toolbar, click  **Booleans and Partitions** and choose **Union**.
- 2 Select the objects **rot2(1)**, **rot2(2)**, **rot2(3)**, **rot2(4)**, **rot2(5)**, and **rot2(6)** only.
- 3 In the **Settings** window for **Union**, locate the **Union** section.
- 4 Clear the **Keep interior boundaries** checkbox.
- 5 Click  **Build Selected**.

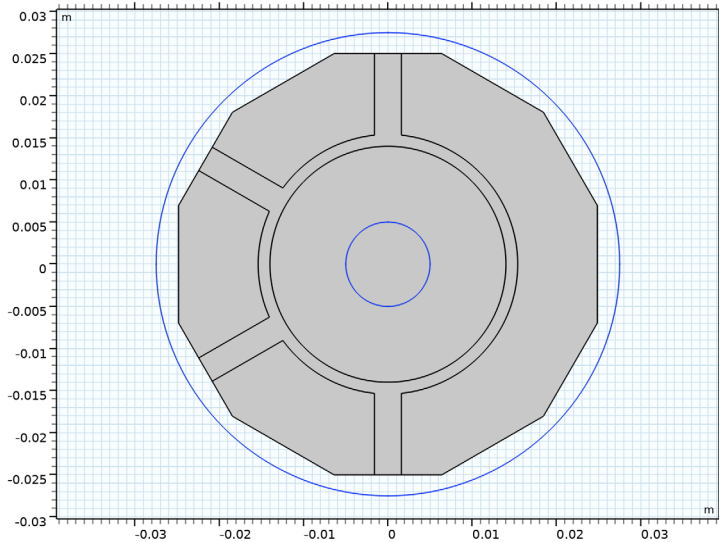

This is the rat race coupler layout on the *xy*-plane.

Turn the coupler layout into a 3D structure by extruding the layout.

Extrude 1 (ext1)

- 1 In the **Model Builder** window, under **Component 1 (comp1) > Geometry 1** right-click **Work Plane 1 (wp1)** and choose **Extrude**.

2 In the **Settings** window for **Extrude**, click  **Build All Objects**.

3 Locate the **Distances** section. In the table, enter the following settings:

| Distances (m) |
|----------------------|
| d_sub |

4 Click  **Build All Objects**.

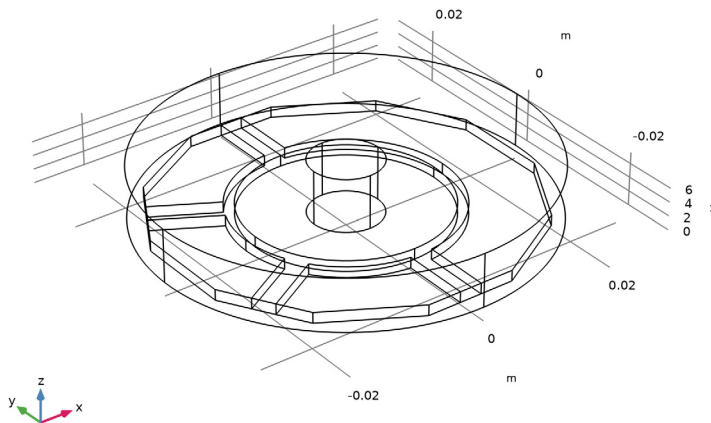

DEFINITIONS

Create a set of selections for use while setting up the physics. First, create a selection for the substrate.

Substrate

1 In the **Definitions** toolbar, click  **Explicit**.

2 In the **Settings** window for **Explicit**, type Substrate in the **Label** text field.

3 Select Domains 2–6 and 9 only.

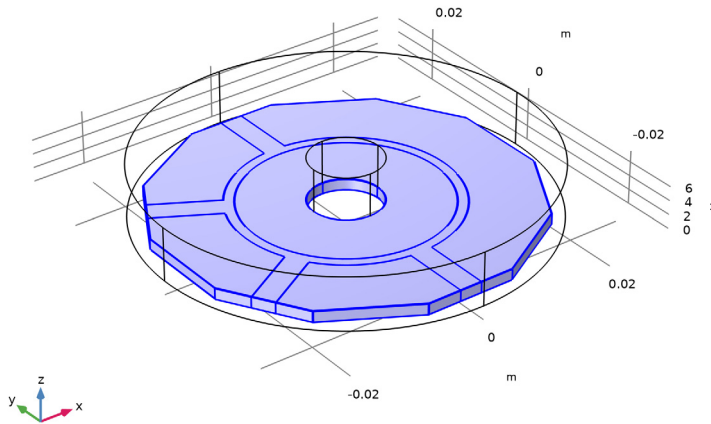

Next, add a selection for the microstrip line.

Microstrip line

- 1 In the **Definitions** toolbar, click  **Explicit**.
- 2 In the **Settings** window for **Explicit**, type **Microstrip line** in the **Label** text field.
- 3 Locate the **Input Entities** section. From the **Geometric entity level** list, choose **Boundary**.

4 Select Boundary 13 only.

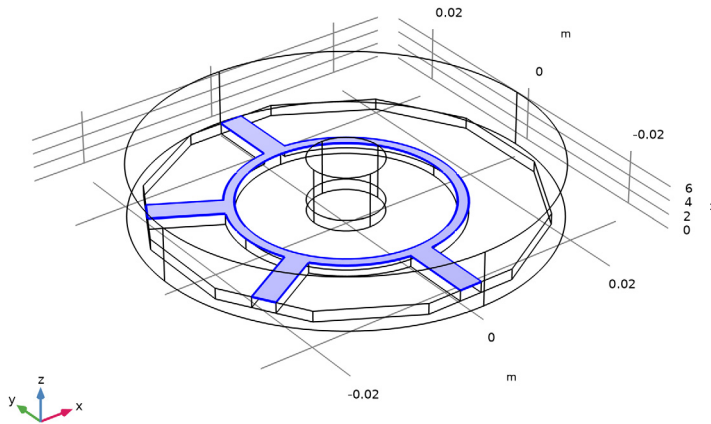

Add a selection for the cylindrical post in the cavity. This domain is not a part of the modeling domain.

Post

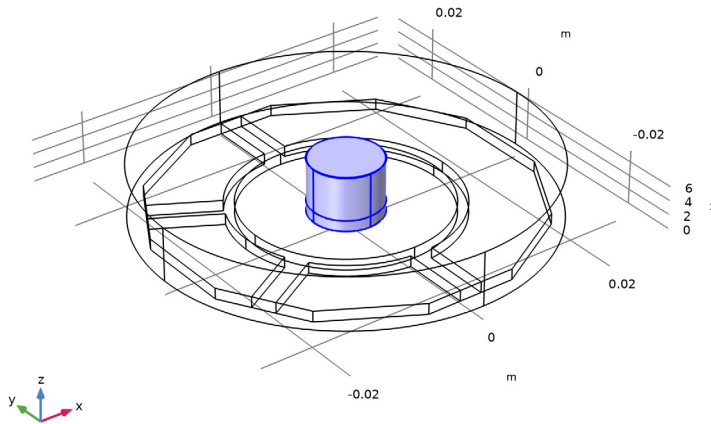

- 1 In the **Definitions** toolbar, click  **Explicit**.
- 2 In the **Settings** window for **Explicit**, type **Post** in the **Label** text field.

3 Select Domains 7 and 8 only.



Add a selection for the modeling domain. This is the complement of the cylindrical post domain.

Model space

- 1 In the **Definitions** toolbar, click  **Complement**.
- 2 In the **Settings** window for **Complement**, type `Model space` in the **Label** text field.
- 3 Locate the **Input Entities** section. Under **Selections to invert**, click  **Add**.
- 4 In the **Add** dialog, select **Post** in the **Selections to invert** list.

5 Click **OK**.

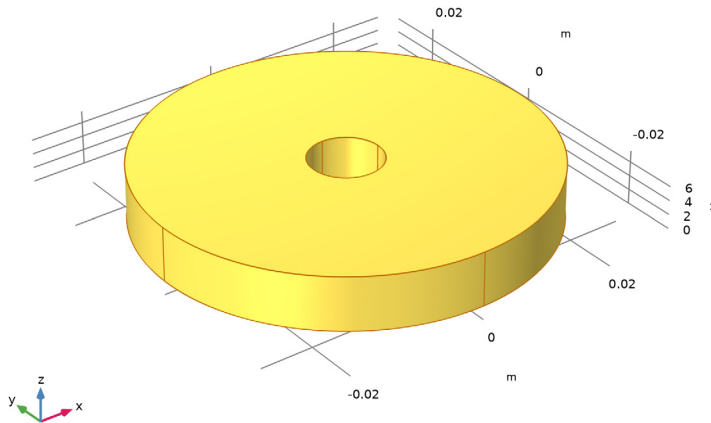

View 1

Hide some boundaries to get a better view of the interior parts when setting up the physics and reviewing the mesh.

Hide for Physics 1

- 1 In the **Model Builder** window, right-click **View 1** and choose **Hide for Physics**.
- 2 In the **Settings** window for **Hide for Physics**, locate the **Geometric Entity Selection** section.
- 3 From the **Geometric entity level** list, choose **Boundary**.

4 Select Boundaries 1, 2, and 4 only.

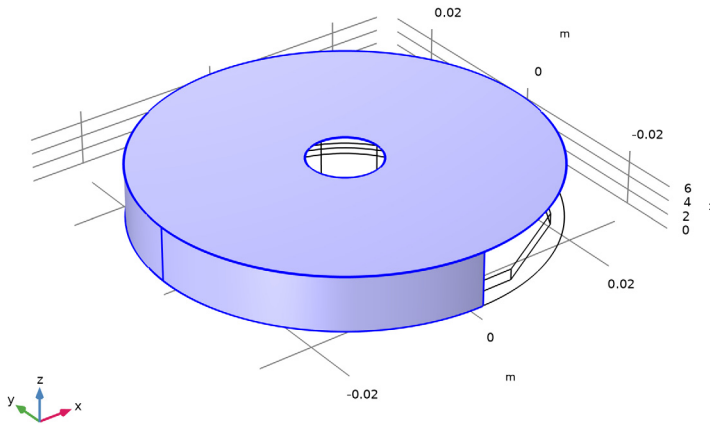

ELECTROMAGNETIC WAVES, FREQUENCY DOMAIN (EMW)

Now set up the physics.

- 1 In the **Model Builder** window, under **Component 1 (comp1)** click **Electromagnetic Waves, Frequency Domain (emw)**.
- 2 In the **Settings** window for **Electromagnetic Waves, Frequency Domain**, locate the **Domain Selection** section.
- 3 From the **Selection** list, choose **Model space**.

The default boundary condition is Perfect electric conductor, which applies to all exterior boundaries. Assign Perfect electric conductor on the interior boundary on the microstrip lines.

Perfect Electric Conductor 2

- 1 In the **Physics** toolbar, click  **Boundaries** and choose **Perfect Electric Conductor**.
- 2 In the **Settings** window for **Perfect Electric Conductor**, locate the **Boundary Selection** section.
- 3 From the **Selection** list, choose **Microstrip line**.
Set four ports as shown in [Figure 2](#).

Lumped Port 1

- 1 In the **Physics** toolbar, click  **Boundaries** and choose **Lumped Port**.
- 2 Select Boundary 14 only.

For the first port, wave excitation is **on** by default.

Lumped Port 2

- 1 In the **Physics** toolbar, click  **Boundaries** and choose **Lumped Port**.
- 2 Select Boundary 46 only.

Lumped Port 3

- 1 In the **Physics** toolbar, click  **Boundaries** and choose **Lumped Port**.
- 2 Select Boundary 10 only.



Lumped Port 4

- 1 In the **Physics** toolbar, click  **Boundaries** and choose **Lumped Port**.
- 2 Select Boundary 44 only.

MATERIALS

Next, assign material properties to the model. Begin by specifying air for all domains.

ADD MATERIAL

- 1 In the **Materials** toolbar, click  **Add Material** to open the **Add Material** window.
- 2 Go to the **Add Material** window.
- 3 In the tree, select **Built-in > Air**.
- 4 Click the **Add to Component** button in the window toolbar.
- 5 In the **Materials** toolbar, click  **Add Material** to close the **Add Material** window.

MATERIALS

Air (mat1)

Override the substrate with the dielectric material of $\epsilon_r = 3.38$.

Substrate

- 1 In the **Model Builder** window, right-click **Materials** and choose **Blank Material**.
- 2 In the **Settings** window for **Material**, type Substrate in the **Label** text field.
- 3 Locate the **Geometric Entity Selection** section. From the **Selection** list, choose **Substrate**.

4 Locate the **Material Contents** section. In the table, enter the following settings:

| Property | Variable | Value | Unit | Property group |
|-----------------------|---|-------|------|----------------|
| Relative permittivity | epsilon _{r_} iso ; epsilon _{r_} ii = epsilon _{r_} iso, epsilon _{r_} ij = 0 | 3.38 | | Basic |
| Relative permeability | mu _{r_} iso ; mu _{r_} ii = mu _{r_} iso, mu _{r_} ij = 0 | 1 | | Basic |
| Electric conductivity | sigma _{iso} ; sigma _{ii} = sigma _{iso} , sigma _{ij} = 0 | 0 | S/m | Basic |

MESH I

In the **Model Builder** window, under **Component I (comp1)** right-click **Mesh I** and choose **Build All**.

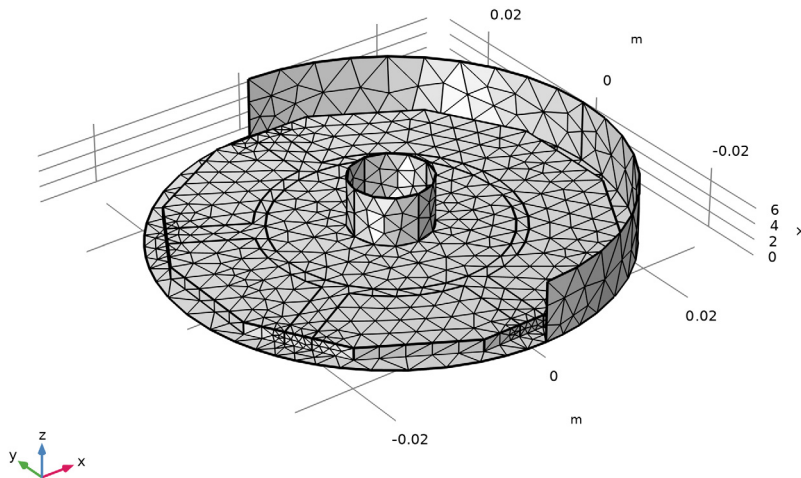

STUDY I

In the **Study** toolbar, click **Compute**.

RESULTS

Electric Field (emw)

Begin the results analysis and visualization by modifying the first default plot to show the E-field norm on the bottom of the substrate at 3 GHz.

- 1 In the **Settings** window for **3D Plot Group**, locate the **Data** section.
- 2 From the **Parameter value (freq (GHz))** list, choose **3**.

Multislice 1

- 1 In the **Model Builder** window, expand the **Electric Field (emw)** node, then click **Multislice 1**.
- 2 In the **Settings** window for **Multislice**, locate the **Multiplane Data** section.
- 3 Find the **X-planes** subsection. In the **Planes** text field, type 0.
- 4 Find the **Y-planes** subsection. In the **Planes** text field, type 0.
- 5 Find the **Z-planes** subsection. From the **Entry method** list, choose **Coordinates**.
- 6 In the **Coordinates** text field, type 0.
- 7 In the **Electric Field (emw)** toolbar, click  **Plot**.

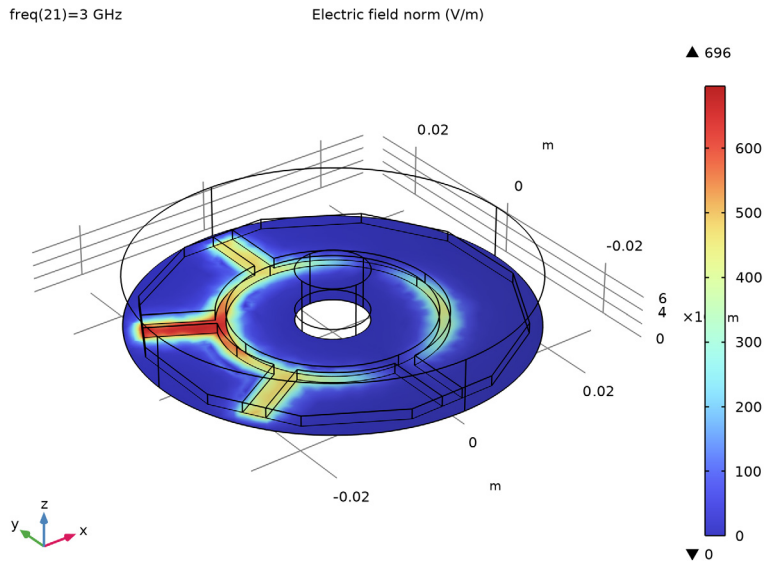

The input power is evenly split between the two output ports.

S-Parameter (emw)

- 1 In the **Model Builder** window, under **Results** click **S-Parameter (emw)**.
- 2 In the **Settings** window for **ID Plot Group**, locate the **Legend** section.
- 3 From the **Position** list, choose **Lower right**.

Compare the resulting plot with that shown in [Figure 3](#).

Next, change some port settings to run the device as a power combiner and see the performance at the sum and difference ports.

Smith Plot (emw)

In the **Model Builder** window, click **Smith Plot (emw)**.

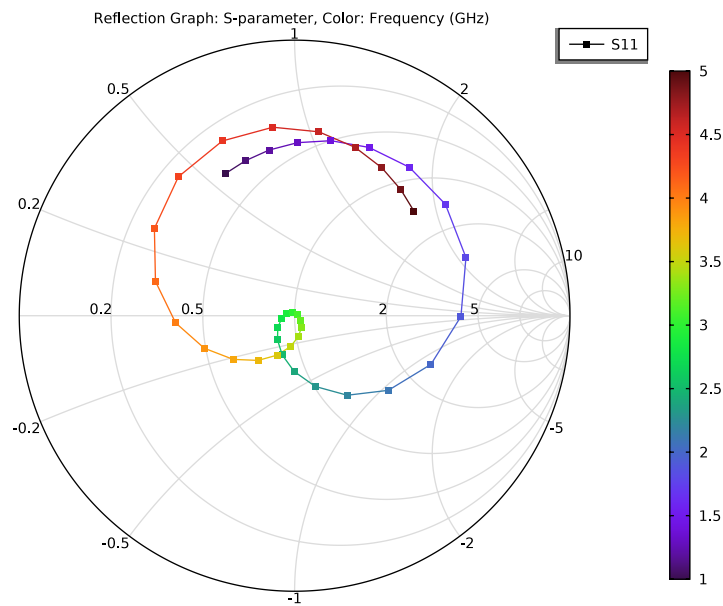

Electric Field, Logarithmic (emw)

In the **Model Builder** window, click **Electric Field, Logarithmic (emw)**.

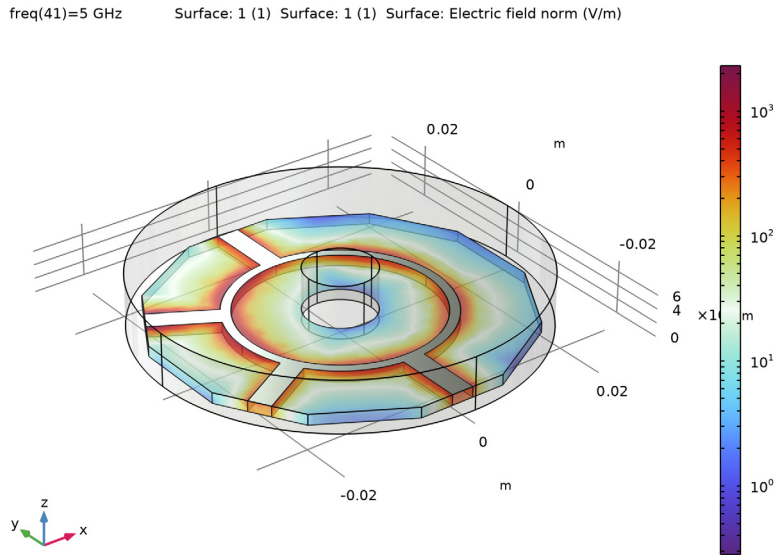

ELECTROMAGNETIC WAVES, FREQUENCY DOMAIN (EMW)

Lumped Port 1

- 1 In the **Model Builder** window, under **Component 1 (comp1) > Electromagnetic Waves, Frequency Domain (emw)** click **Lumped Port 1**.
- 2 In the **Settings** window for **Lumped Port**, locate the **Lumped Port Properties** section.
- 3 From the **Wave excitation at this port** list, choose **Off**.

Lumped Port 2



- 1 In the **Model Builder** window, click **Lumped Port 2**.
- 2 In the **Settings** window for **Lumped Port**, locate the **Lumped Port Properties** section.
- 3 From the **Wave excitation at this port** list, choose **On**.

Lumped Port 3

- 1 In the **Model Builder** window, click **Lumped Port 3**.
- 2 In the **Settings** window for **Lumped Port**, locate the **Lumped Port Properties** section.
- 3 From the **Wave excitation at this port** list, choose **On**.



Add a new study for the coupler (power divider) case in order to keep the result from the previous computation.

ADD STUDY

- 1 In the **Home** toolbar, click  **Add Study** to open the **Add Study** window.
- 2 Go to the **Add Study** window.
- 3 Find the **Studies** subsection. In the **Select Study** tree, select **General Studies** > **Frequency Domain**.
- 4 Click the **Add Study** button in the window toolbar.
- 5 In the **Home** toolbar, click  **Add Study** to close the **Add Study** window.

STUDY 2

Step 1: Frequency Domain

- 1 In the **Settings** window for **Frequency Domain**, locate the **Study Settings** section.
- 2 Click  **Range**.
- 3 In the **Range** dialog, type 1 [GHz] in the **Start** text field.
- 4 In the **Stop** text field, type 5 [GHz].
- 5 In the **Step** text field, type 100 [MHz].
- 6 Click **Replace**.
- 7 In the **Model Builder** window, click **Study 2**.
- 8 In the **Settings** window for **Study**, locate the **Study Settings** section.
- 9 Clear the **Generate default plots** checkbox.
- 10 In the **Study** toolbar, click  **Compute**.

RESULTS

ID Plot Group 6

- 1 In the **Results** toolbar, click  **ID Plot Group**.
- 2 In the **Settings** window for **ID Plot Group**, locate the **Data** section.
- 3 From the **Dataset** list, choose **Study 2/Solution 2 (sol2)**.
- 4 Locate the **Legend** section. From the **Position** list, choose **Lower right**.

Global 1

- 1 Right-click **ID Plot Group 6** and choose **Global**.
- 2 In the **Settings** window for **Global**, locate the **y-Axis Data** section.

3 In the table, enter the following settings:

| Expression | Unit | Description |
|---|------|-------------------------------|
| $20 \cdot \log_{10}(\text{emw.Vport_1})$ | | Voltage at port 1 in dB scale |
| $20 \cdot \log_{10}(\text{emw.Vport_2})$ | | Voltage at port 2 in dB scale |
| $20 \cdot \log_{10}(\text{emw.Vport_3})$ | | Voltage at port 3 in dB scale |
| $20 \cdot \log_{10}(\text{emw.Vport_4})$ | | Voltage at port 4 in dB scale |

4 In the **ID Plot Group 6** toolbar, click  **Plot**.

Compare the resulting plot with that shown in [Figure 4](#).

Lossy microstrip lines with multiple layers can be addressed using a **Layered Transition Boundary Condition**. Change the lumped port settings back as in the first study, and prepare materials in multiple layers.

ELECTROMAGNETIC WAVES, FREQUENCY DOMAIN (EMW)

Lumped Port 1

1 In the **Model Builder** window, under **Component 1 (comp1) > Electromagnetic Waves, Frequency Domain (emw)** click **Lumped Port 1**.

2 In the **Settings** window for **Lumped Port**, locate the **Lumped Port Properties** section.

3 From the **Wave excitation at this port** list, choose **On**.

Lumped Port 2

1 In the **Model Builder** window, click **Lumped Port 2**.

2 In the **Settings** window for **Lumped Port**, locate the **Lumped Port Properties** section.

3 From the **Wave excitation at this port** list, choose **Off**.

Lumped Port 3

1 In the **Model Builder** window, click **Lumped Port 3**.

2 In the **Settings** window for **Lumped Port**, locate the **Lumped Port Properties** section.

3 From the **Wave excitation at this port** list, choose **Off**.

Perfect Electric Conductor 2

In the **Model Builder** window, right-click **Perfect Electric Conductor 2** and choose **Disable**.

ADD MATERIAL

1 In the **Materials** toolbar, click  **Add Material** to open the **Add Material** window.

2 Go to the **Add Material** window.

- 3 In the tree, select **Built-in > Aluminum 6063-T83**.
- 4 Click the **Add to Global Materials** button in the window toolbar.
- 5 In the tree, select **Built-in > Copper**.
- 6 Click the **Add to Global Materials** button in the window toolbar.
- 7 In the **Materials** toolbar, click  **Add Material** to close the **Add Material** window.

GLOBAL DEFINITIONS

Layered Material 1 (lmat1)

- 1 In the **Model Builder** window, under **Global Definitions** right-click **Materials** and choose **Layered Material**.
- 2 In the **Settings** window for **Layered Material**, locate the **Layer Definition** section.
- 3 In the table, enter the following settings:

| Layer | Material | Rotation | Value | Thickness | Mesh elements |
|---------|--------------------------|----------|-------|-----------|---------------|
| Layer 1 | Aluminum 6063-T83 (mat3) | 0.0 | 0 rad | 20 [um] | 2 |

- 4 Click  **Add**.
- 5 In the table, enter the following settings:

| Layer | Material | Rotation | Value | Thickness | Mesh elements |
|---------|---------------|----------|-------|-----------|---------------|
| Layer 2 | Copper (mat4) | 0.0 | 0 rad | 20 [um] | 2 |

MATERIALS

Layered Material Link 1 (lmat1)

- 1 In the **Model Builder** window, under **Component 1 (comp1)** right-click **Materials** and choose **Layers > Layered Material Link**.
- 2 Select Boundary 13 only.



ELECTROMAGNETIC WAVES, FREQUENCY DOMAIN (EMW)

Layered Transition Boundary Condition 1

- 1 In the **Physics** toolbar, click  **Boundaries** and choose **Layered Transition Boundary Condition**.

2 Select Boundary 13 only.

ADD STUDY

- 1 In the **Home** toolbar, click  **Add Study** to open the **Add Study** window.
- 2 Go to the **Add Study** window.
- 3 Find the **Studies** subsection. In the **Select Study** tree, select **General Studies** > **Frequency Domain**.
- 4 Click the **Add Study** button in the window toolbar.
- 5 In the **Home** toolbar, click  **Add Study** to close the **Add Study** window.

STUDY 3

Step 1: Frequency Domain

- 1 In the **Settings** window for **Frequency Domain**, locate the **Study Settings** section.
- 2 In the **Frequencies** text field, type range (1 [GHz], 100 [MHz], 5 [GHz]).
- 3 In the **Study** toolbar, click  **Compute**.

RESULTS

Multislice 1

- 1 In the **Model Builder** window, expand the **Electric Field (emw) 1** node, then click **Multislice 1**.
- 2 In the **Settings** window for **Multislice**, locate the **Multiphase Data** section.
- 3 Find the **X-planes** subsection. In the **Planes** text field, type 0.
- 4 Find the **Y-planes** subsection. In the **Planes** text field, type 0.
- 5 Find the **Z-planes** subsection. From the **Entry method** list, choose **Coordinates**.
- 6 In the **Coordinates** text field, type 0.

7 Locate the **Coloring and Style** section. From the **Color table** list, choose **ThermalWaveDark**.

freq(41)=5 GHz

Electric field norm (V/m)

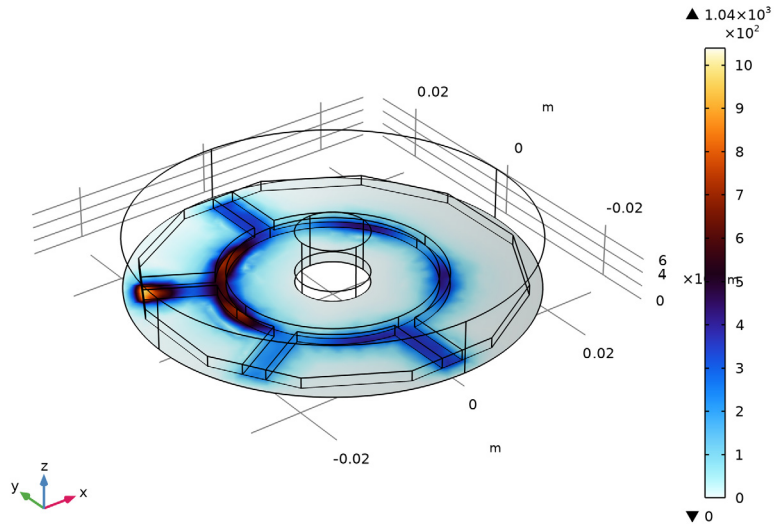

S-Parameter (emw) I

In the **Model Builder** window, under **Results** click **S-Parameter (emw) I**.

