



Model created in COMSOL Multiphysics 6.4

Modeling of Pyramidal Absorbers for an Anechoic Chamber

Introduction

In this example, a microwave absorber is constructed from an infinite 2D array of pyramidal lossy structures. Pyramidal absorbers with radiation-absorbent material (RAM) are commonly used in anechoic chambers for electromagnetic wave measurements. Microwave absorption is modeled using a lossy material to imitate the electromagnetic properties of conductive carbon-loaded foam.

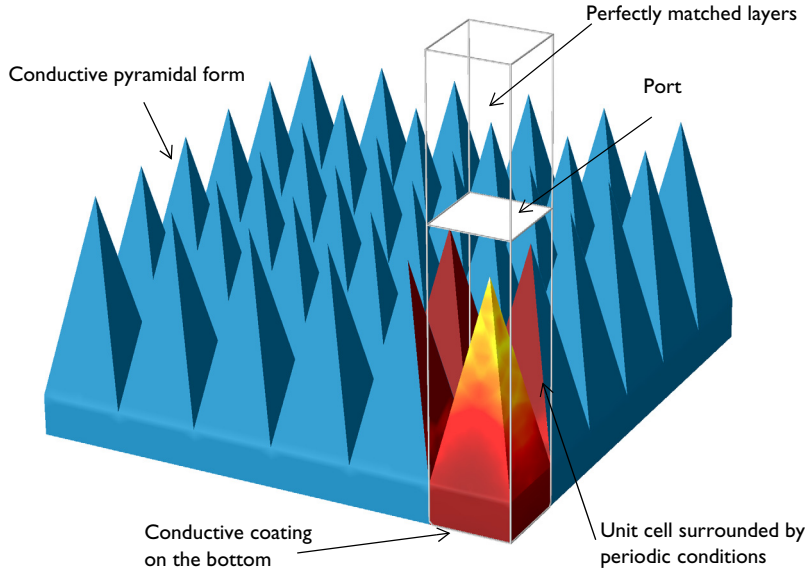

Figure 1: An infinite 2D array of pyramidal absorbers is modeled using periodic boundary conditions on the sides of one unit cell.

Model Definition

The infinite 2D array of pyramidal structures is modeled using one unit cell with Floquet-periodic boundary conditions on four sides, as shown in [Figure 1](#). The geometry of one unit cell consists of one pyramid sitting on a block made of the same material. There are perfectly matched layers (PMLs) above the pyramid and the remaining space between the pyramid and the PMLs is filled with air.

The pyramidal absorber is made of a conductive material ($\sigma = 0.5 \text{ S/m}$). At the interface of the conductive material and air, the incident field is partially reflected and partially transmitted into the pyramid. The transmitted field is attenuated inside of the lossy

material. For angles within a particular range of normal incidence, the propagation direction of the reflected field is not back toward the source, but instead toward another surface of the conductive material. The process of partial reflection and partial transmission with subsequent attenuation is repeated until the field reaches the base of the pyramid. The amplitude of the field at the base of the pyramid is drastically reduced and so the reflection from the absorber at this point is marginal. The process is illustrated in Figure 2.

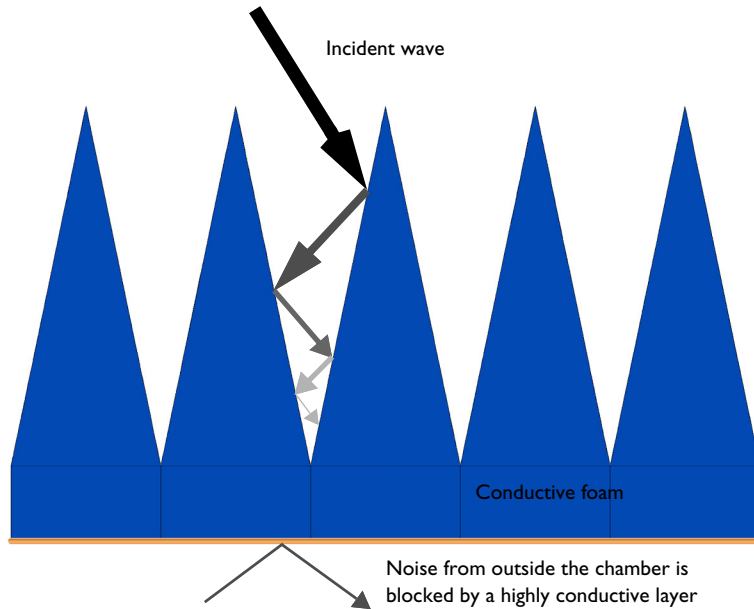

Figure 2: The incident wave is partially transmitted into the conductive foam where it is subsequently attenuated. For angles within a particular range of normal incidence, the reflected component of the field propagates toward another conducting surface where the process is repeated.

The bottom of the absorber has a thin highly conductive layer to block any noise from outside the anechoic chamber. Before mounting absorbers on the walls of the anechoic chamber, it is necessary to apply a conductive coating on the walls, which is modeled as a perfect electric conductor (PEC).

The model domain immediately outside of the conducting foam is filled with air. Perfectly matched layers (PMLs) above the air at the top of the unit cell absorb higher-order modes generated by the periodic structure — if there are any — as well as the upward traveling excited mode from the source port. The PMLs attenuate the field in the direction

perpendicular to the PML boundary. Since the model is solved for a range of incident angles, the wavelength inside the PMLs is set to $2\pi/|k_0\cos\theta|$, which, in some sense, is the wavelength of the normal component of the wave vector.

A port boundary condition is placed on the interior boundary of the PMLs, adjacent to the air domain. The interior port boundaries with PML backing require the slit condition that can be found in the port settings. The port orientation is specified to define the inward direction for the S-parameter calculation. Since higher order diffraction modes are not of particular interest in this example, the combination of a Domain-backed type slit port and PMLs is used instead of adding a Diffraction order port for each diffraction order and polarization.

The periodic boundary condition requires identical surface meshes on paired boundaries. An identical surface mesh can be created by using the Copy Face operation from one boundary to another boundary.

Results and Discussion

[Figure 3](#) shows the norm of the electric field and power flow in the case where the elevation angle of incidence is 30 degrees and the azimuth angle is zero. The intensity of the illuminating wave is strong near the tip of the absorber. It decreases toward the base of the pyramid, where it is ultimately very weak.

The S-parameter for *y*-axis polarized incident waves is plotted in [Figure 4](#). The plot shows quantitatively that the absorber performs well for a range of incident elevation angles less than 40 degrees.

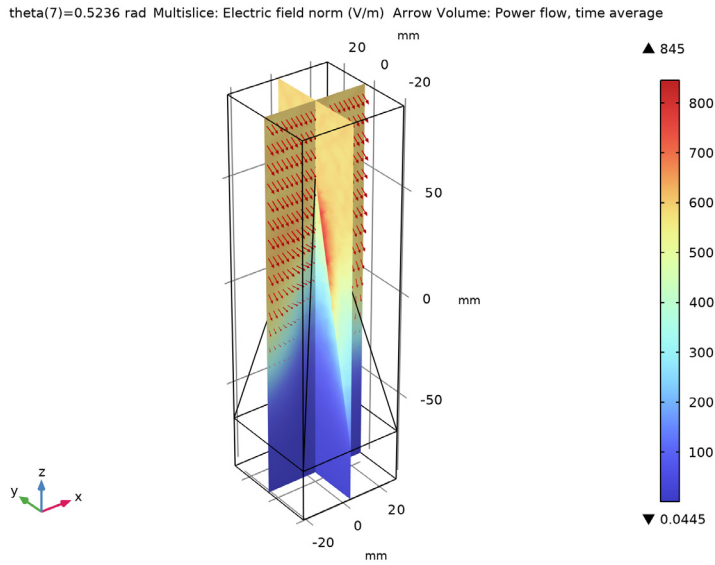

Figure 3: The power flow and the default multislice plot of the electric field norm for the case where the elevation angle of incidence is 30 degrees and the azimuthal angle is zero.

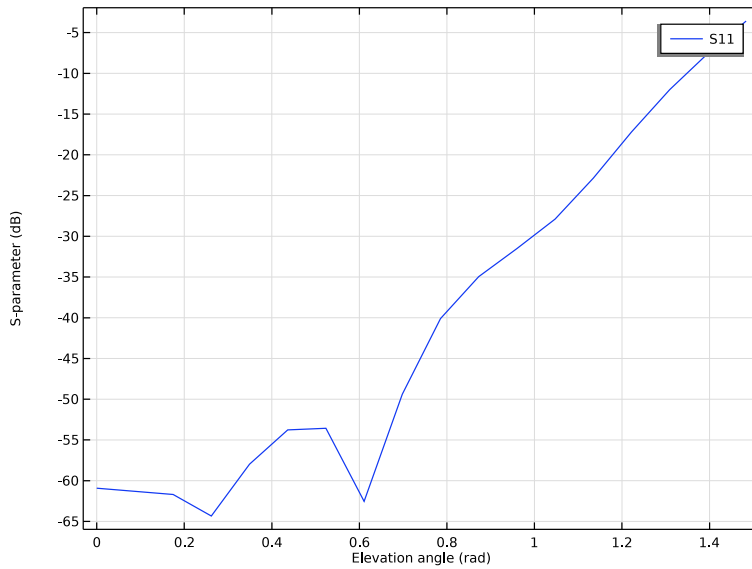



Figure 4: The S-parameter is plotted as a function of incident angle.

Application Library path: RF_Module/EMI_EMG_Applications/
pyramidal_absorber



Modeling Instructions

From the **File** menu, choose **New**.

NEW

In the **New** window, click  **Model Wizard**.

MODEL WIZARD

- 1 In the **Model Wizard** window, click  **3D**.
- 2 In the **Select Physics** tree, select **Radio Frequency > Electromagnetic Waves, Frequency Domain (emw)**.
- 3 Click **Add**.
- 4 Click  **Study**.
- 5 In the **Select Study** tree, select **General Studies > Frequency Domain**.
- 6 Click  **Done**.

STUDY I

Step 1: Frequency Domain

Define the study frequency ahead of performing any frequency-dependent operation such as building mesh. The physics-controlled mesh uses the specified frequency value.

- 1 In the **Model Builder** window, under **Study I** click **Step 1: Frequency Domain**.
- 2 In the **Settings** window for **Frequency Domain**, locate the **Study Settings** section.
- 3 In the **Frequencies** text field, type 5[GHz].

GEOMETRY I

- 1 In the **Model Builder** window, under **Component 1 (comp1)** click **Geometry 1**.
- 2 In the **Settings** window for **Geometry**, locate the **Units** section.
- 3 From the **Length unit** list, choose **mm**.

GLOBAL DEFINITIONS



Parameters 1

- 1 In the **Model Builder** window, under **Global Definitions** click **Parameters 1**.
- 2 In the **Settings** window for **Parameters**, locate the **Parameters** section.
- 3 In the table, enter the following settings:

Name	Expression	Value	Description
theta	0[deg]	0 rad	Elevation angle

GEOMETRY 1

Block 1 (blk1)

- 1 In the **Geometry** toolbar, click  **Block**.
- 2 In the **Settings** window for **Block**, locate the **Size and Shape** section.
- 3 In the **Width** text field, type 50.
- 4 In the **Depth** text field, type 50.
- 5 In the **Height** text field, type 280.
- 6 Locate the **Position** section. In the **x** text field, type -25.
- 7 In the **y** text field, type -25.
- 8 In the **z** text field, type -90.
- 9 Click  **Build Selected**.
- 10 Click the  **Wireframe Rendering** button in the **Graphics** toolbar.

Block 2 (blk2)



- 1 In the **Geometry** toolbar, click  **Block**.
- 2 In the **Settings** window for **Block**, locate the **Size and Shape** section.
- 3 In the **Width** text field, type 50.
- 4 In the **Depth** text field, type 50.
- 5 In the **Height** text field, type 180.
- 6 Locate the **Position** section. From the **Base** list, choose **Center**.

Block 3 (blk3)

- 1 In the **Geometry** toolbar, click  **Block**.
- 2 In the **Settings** window for **Block**, locate the **Size and Shape** section.
- 3 In the **Width** text field, type 50.

- 4 In the **Depth** text field, type 50.
- 5 In the **Height** text field, type 25.
- 6 Locate the **Position** section. From the **Base** list, choose **Center**.
- 7 In the **z** text field, type -77.5.

Pyramid 1 (pyr1)

- 1 In the **Geometry** toolbar, click  **More Primitives** and choose **Pyramid**.
- 2 In the **Settings** window for **Pyramid**, locate the **Size and Shape** section.
- 3 In the **Base length 1** text field, type 50.
- 4 In the **Base length 2** text field, type 50.
- 5 In the **Height** text field, type 120.
- 6 In the **Ratio** text field, type 0.
- 7 Locate the **Position** section. In the **z** text field, type -65.
- 8 Click  **Build All Objects**.

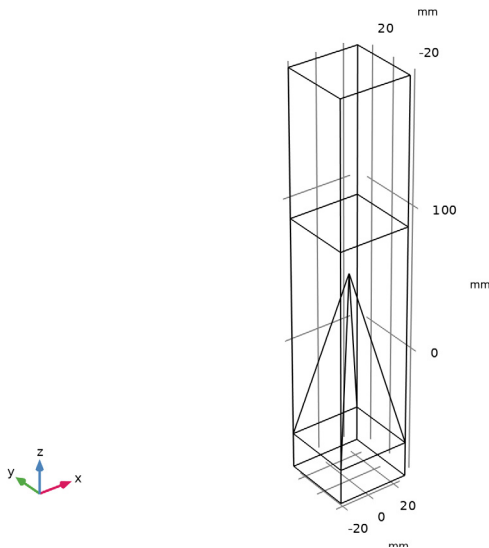

The finished geometry should look like this.

Set up the physics based on the direction of propagation and the E-field polarization. Assume a TE-polarized wave which is equivalent to *s*-polarization and perpendicular polarization. E_x and E_z are zero while E_y is dominant.

ELECTROMAGNETIC WAVES, FREQUENCY DOMAIN (EMW)

Periodic Condition 1

- 1 In the **Physics** toolbar, click  **Boundaries** and choose **Periodic Condition**.
- 2 Select Boundaries 1, 4, 9, and 18–20 only.

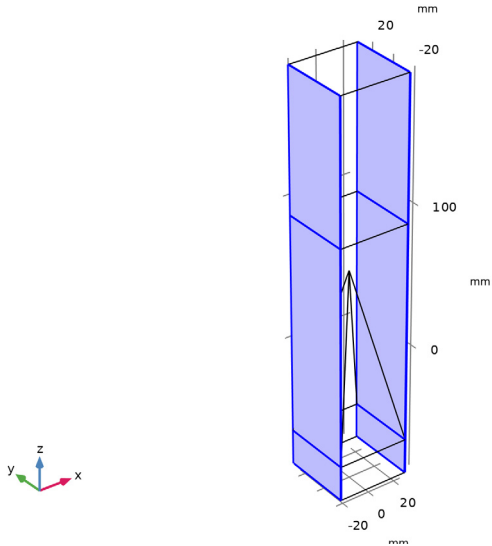

- 3 In the **Settings** window for **Periodic Condition**, locate the **Periodicity Settings** section.
- 4 From the **Type of periodicity** list, choose **Floquet periodicity**.
- 5 From the **k-vector for Floquet periodicity** list, choose **From periodic port**.

Periodic Condition 2

- 1 In the **Physics** toolbar, click  **Boundaries** and choose **Periodic Condition**.

2 Select Boundaries 2, 5, 10, 13, 14, and 16 only.

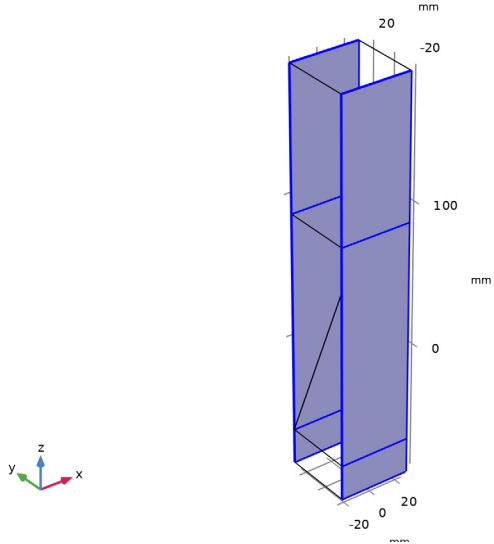

3 In the **Settings** window for **Periodic Condition**, locate the **Periodicity Settings** section.

4 From the **Type of periodicity** list, choose **Floquet periodicity**.

5 From the **k-vector for Floquet periodicity** list, choose **From periodic port**.

Port 1

1 In the **Physics** toolbar, click  **Boundaries** and choose **Port**.

2 Select Boundary 11 only.

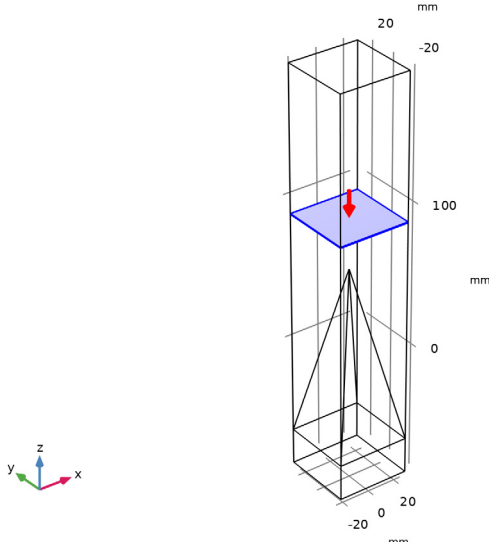

3 In the **Settings** window for **Port**, locate the **Port Properties** section.

4 From the **Type of port** list, choose **Periodic**.

For the first port, wave excitation is **on** by default.

5 Select the **Activate slit condition on interior port** checkbox.

6 Click **Toggle Power Flow Direction**.

7 Locate the **Port Mode Settings** section. Specify the \mathbf{E}_0 vector as

0	x
1	y
0	z

8 In the α_1 text field, type theta.

The maximum frequency in the setting window will be used only when **Compute Diffraction Order** button is clicked to generate Diffraction Order features handling higher order mode individually. In this model, PML absorbs all higher order modes, so this setting is ineffective.

Scattering Boundary Condition 1

1 In the **Physics** toolbar, click  **Boundaries** and choose **Scattering Boundary Condition**.

2 Select Boundary 12 only.

DEFINITIONS

Perfectly Matched Layer 1 (pml1)

- 1 In the **Definitions** toolbar, click  **Perfectly Matched Layer**.
- 2 Select Domain 4 only.

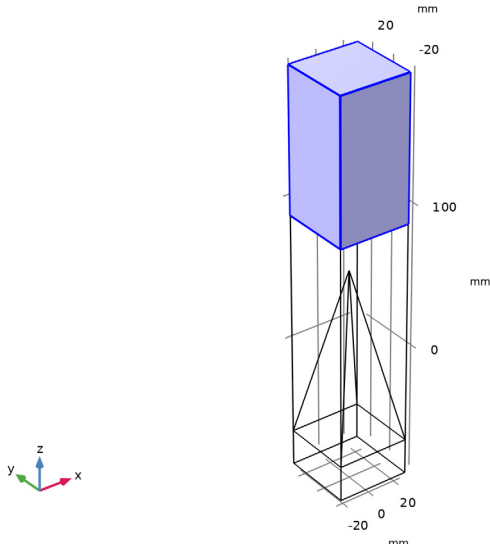

MATERIALS

Material 1 (mat1)

- 1 In the **Model Builder** window, under **Component 1 (comp1)** right-click **Materials** and choose **Blank Material**.
- 2 In the **Settings** window for **Material**, locate the **Material Contents** section.
- 3 In the table, enter the following settings:

Property	Variable	Value	Unit	Property group
Relative permittivity	epsilon _{r_iso} ; epsilon _{r_ii} = epsilon _{r_iso} , epsilon _{r_ij} = 0	1		Basic

Property	Variable	Value	Unit	Property group
Relative permeability	mur_iso ; muri = mur_iso , $\text{murij} = 0$	1		Basic
Electric conductivity	sigma_iso ; sigmai = sigma_iso , $\text{sigmaij} = 0$	0	S/m	Basic

Material 2 (mat2)

- 1 Right-click **Materials** and choose **Blank Material**.
- 2 Select Domains 1 and 3 only.

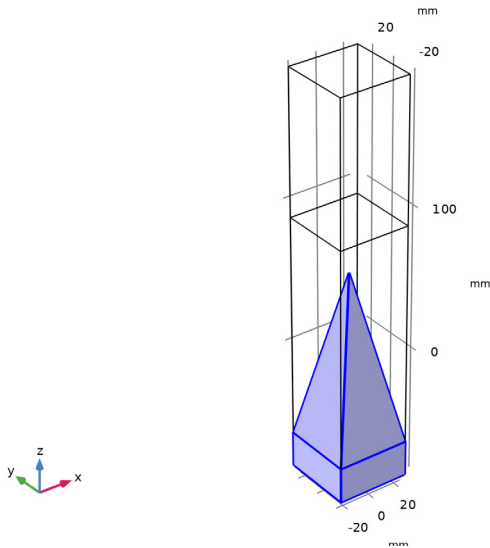

- 3 In the **Settings** window for **Material**, locate the **Material Contents** section.

4 In the table, enter the following settings:

Property	Variable	Value	Unit	Property group
Relative permittivity	epsilon _{r_} iso ; epsilon _{r_} ii = epsilon _{r_} iso, epsilon _{r_} ij = 0	1		Basic
Relative permeability	mu _{r_} iso ; mu _{r_} ii = mu _{r_} iso, mu _{r_} ij = 0	1		Basic
Electric conductivity	sigma _{iso} ; sigma _{ii} = sigma _{iso} , sigma _{ij} = 0	0.5	S/m	Basic

MESH 1

In the **Model Builder** window, under **Component 1 (comp1)** right-click **Mesh 1** and choose **Build All**.

DEFINITIONS

Hide for Physics 1

- 1 In the **Model Builder** window, right-click **View 1** and choose **Hide for Physics**.
- 2 Select Domain 4 only.
- 3 In the **Settings** window for **Hide for Physics**, locate the **Geometric Entity Selection** section.
- 4 From the **Geometric entity level** list, choose **Boundary**.
- 5 Select Boundaries 4, 5, 9, and 10 only.

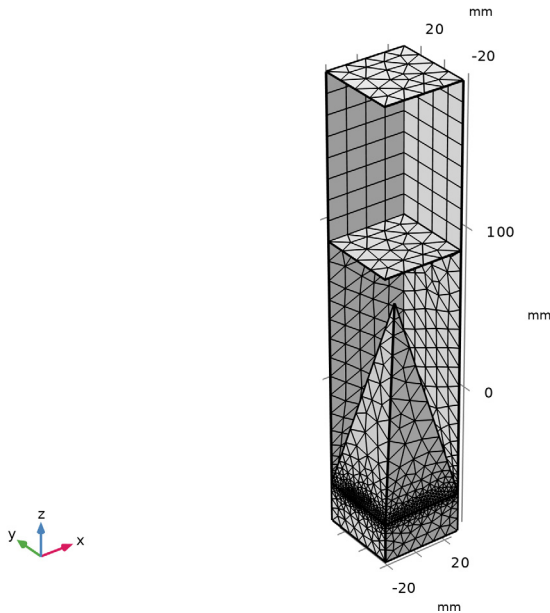

MESH 1

In the **Model Builder** window, under **Component 1 (comp1)** click **Mesh 1**.



STUDY 1

Parametric Sweep

- 1 In the **Study** toolbar, click  **Parametric Sweep**.
- 2 In the **Settings** window for **Parametric Sweep**, locate the **Study Settings** section.
- 3 Click  **Add**.
- 4 In the table, enter the following settings:

Parameter name	Parameter value list	Parameter unit
theta (Elevation angle)	range (0[deg], 5[deg], 85[deg])	rad

- 5 In the **Study** toolbar, click  **Compute**.

RESULTS

Study 1/Solution 1 (sol1)

In the **Model Builder** window, expand the **Results > Datasets** node, then click **Study 1/Solution 1 (sol1)**.

Selection

- 1 In the **Results** toolbar, click  **Attributes** and choose **Selection**.
- 2 In the **Settings** window for **Selection**, locate the **Geometric Entity Selection** section.
- 3 From the **Geometric entity level** list, choose **Domain**.
- 4 Select Domains 1–3 only.



Multislice 1

- 1 In the **Model Builder** window, expand the **Results > Electric Field (emw)** node, then click **Multislice 1**.
- 2 In the **Settings** window for **Multislice**, locate the **Multiplane Data** section.
- 3 Find the **Z-planes** subsection. In the **Planes** text field, type 0.

Arrow Volume 1

- 1 In the **Model Builder** window, right-click **Electric Field (emw)** and choose **Arrow Volume**.
- 2 In the **Settings** window for **Arrow Volume**, click **Replace Expression** in the upper-right corner of the **Expression** section. From the menu, choose **Component 1 (comp1) > Electromagnetic Waves, Frequency Domain > Energy and power > emw.Poavx,..., emw.Poavz - Power flow, time average**.
- 3 Locate the **Arrow Positioning** section. Find the **X grid points** subsection. In the **Points** text field, type 21.
- 4 Find the **Y grid points** subsection. In the **Points** text field, type 1.
- 5 Find the **Z grid points** subsection. In the **Points** text field, type 21.
- 6 In the **Electric Field (emw)** toolbar, click  **Plot**.

Electric Field (emw)

- 1 In the **Model Builder** window, click **Electric Field (emw)**.
- 2 In the **Settings** window for **3D Plot Group**, locate the **Data** section.
- 3 From the **Parameter value (theta (rad))** list, choose **0.5236**.
- 4 In the **Electric Field (emw)** toolbar, click  **Plot**.
- 5 Click the  **Zoom Extents** button in the **Graphics** toolbar.
See [Figure 3](#) to compare the plotted results.

Global 1

- 1 In the **Model Builder** window, expand the **S-Parameter (emw)** node, then click **Global 1**.

- 2 In the **Settings** window for **Global**, click **Replace Expression** in the upper-right corner of the **y-Axis Data** section. From the menu, choose **Component I (comp I) > Electromagnetic Waves, Frequency Domain > Ports > emw.S11 dB - S11 - dB**.

- 3 In the **S-Parameter (emw)** toolbar, click  **Plot**.

The calculated S-parameters at the input port are shown as a function of the incident angle. Compare with that shown in [Figure 4](#).

Electric Field, Logarithmic (emw)

In the **Model Builder** window, under **Results** click **Electric Field, Logarithmic (emw)**.

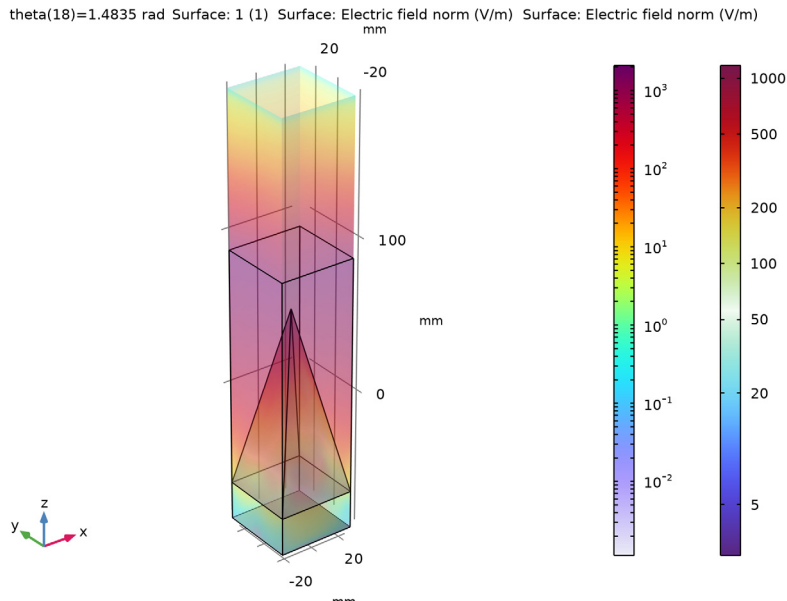

3D Plot Group 7

- 1 In the **Results** toolbar, click  **3D Plot Group**.
- 2 In the **Settings** window for **3D Plot Group**, locate the **Data** section.
- 3 From the **Parameter value (theta (rad))** list, choose **0.5236**.
- 4 Locate the **Plot Settings** section. Clear the **Plot dataset edges** checkbox.

Isosurface 1

- 1 Right-click **3D Plot Group 7** and choose **Isosurface**.
- 2 In the **Settings** window for **Isosurface**, locate the **Levels** section.
- 3 In the **Total levels** text field, type 20.

- 4 Locate the **Coloring and Style** section. From the **Color table** list, choose **Ranitomeya**.

Transparency 1

- 1 In the **Model Builder** window, right-click **Isosurface 1** and choose **Transparency**.
- 2 In the **Settings** window for **Transparency**, locate the **Transparency** section.
- 3 Find the **Transparency** subsection. Set the **Transparency** value to **0.85**.

Surface 1

- 1 In the **Model Builder** window, right-click **3D Plot Group 7** and choose **Surface**.
- 2 In the **Settings** window for **Surface**, locate the **Coloring and Style** section.
- 3 From the **Color table** list, choose **Xylethrus**.

Selection 1

- 1 Right-click **Surface 1** and choose **Selection**.
- 2 Select Boundaries 1, 2, 6, 8, 13, 15, 17, and 18 only.
- 3 In the **3D Plot Group 7** toolbar, click  **Plot**.

theta(7)=0.5236 rad Isosurface: Electric field norm (V/m) Surface: Electric field norm (V/m)

