



Model created in COMSOL Multiphysics 6.4

Polarized Circular Ports

Introduction

This example of a circular waveguide demonstrates how to excite and terminate ports with degenerate port modes. In particular it shows how to model and excite the TE₁₁ mode of circular waveguides in 3D.

Model Definition

A straight piece of circular waveguide with perfect metallic walls is excited by a linearly polarized TE₁₁ mode at one end and ideally terminated at the other end.

The TE₁₁ mode of a circular waveguide is degenerate, meaning that there is an infinite number of possible variants of the TE₁₁ mode that only differ in polarization. Any type of polarization (for example circular polarization) of the TE₁₁ mode can be constructed by or decomposed into two linearly polarized modes. The direction of polarization of the first one can be chosen freely and the second one is obtained from the first one by a rotation of 90 degrees around the waveguide axis.

As a general structure may change the polarization of the incident field as it is transmitted or reflected, ideal termination means that any circular waveguide port that operates in the TE₁₁ mode need to have two port features which are tuned to mutually orthogonal, linear polarizations of the TE₁₁ mode respectively. The reference directions for the two port features are subject to a manual choice but must differ by a rotation of 90 degrees around the waveguide axis.

The Port subfeature, Circular Port Reference Axis is used to determine the reference direction for the polarization of each mode/port by means of selecting two vertices (points) on the port circumference. In this example, extra vertices that are equally distributed along the port edge are added to the geometry to allow for the definition of the desired reference directions.

With the stipulated excitation using the two mutually orthogonal TE₁₁ ports as boundary conditions, the following equation is solved for the electric field vector \mathbf{E} inside the waveguide:

$$\nabla \times (\mu_r^{-1} \nabla \times \mathbf{E}) - k_0^2 \left(\epsilon_r - \frac{j\sigma}{\omega \epsilon_0} \right) \mathbf{E} = 0$$

Results and Discussion

The first TE_{11} mode of the inport is shown in Figure 1.

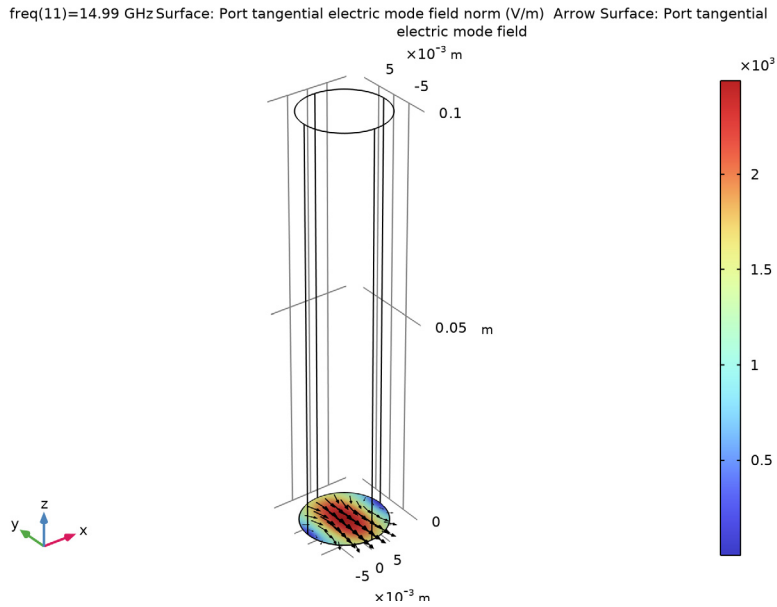

Figure 1: The first TE_{11} mode of the inport

Note: Depending on the details of the mesh, which in turn may depend on the origin of the CAD geometry, a mode that is rotated 180 degrees may be found.

The first TE_{11} mode of the outpost is shown in Figure 2.

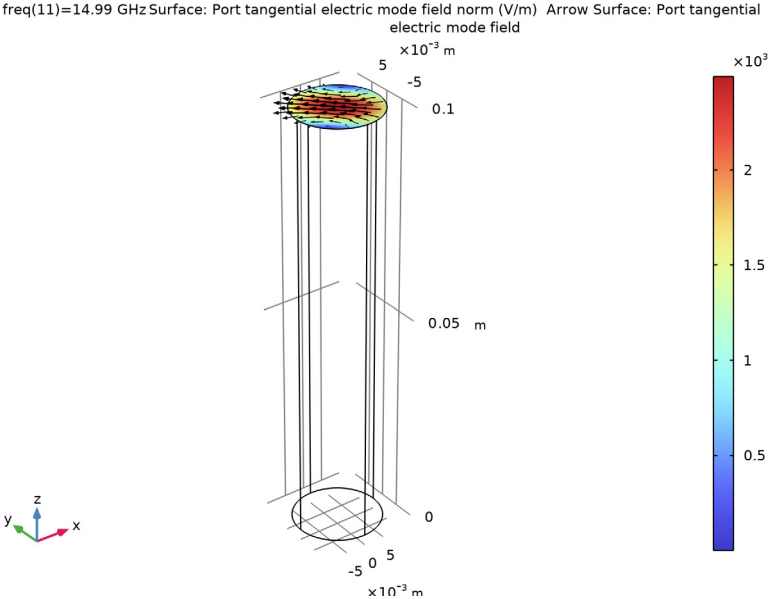

Figure 2: The first TE_{11} mode of the outpost.

Note: Depending on the details of the mesh, which in turn may depend on the origin of the CAD geometry, a mode that is rotated 180 degrees may be found.

The transmission coefficients between the inport and outport modes are shown in Figure 3.

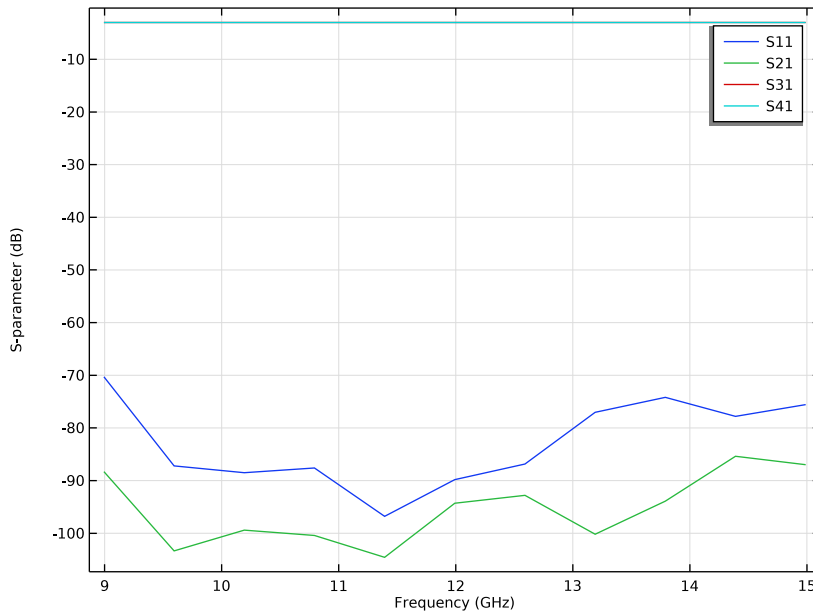



Figure 3: The transmission coefficients between inport modes and outport modes are plotted as a function of frequency. As the port modes are misaligned by 45 degrees the transmission coefficients approach the -3dB level.

Application Library path: RF_Module/Tutorials/polarized_circular_ports

Modeling Instructions



From the **File** menu, choose **New**.

NEW

In the **New** window, click  **Model Wizard**.

MODEL WIZARD

I In the **Model Wizard** window, click  **3D**.

- 2 In the **Select Physics** tree, select **Radio Frequency > Electromagnetic Waves, Frequency Domain (emw)**.
- 3 Click **Add**.
- 4 Click  **Study**.
- 5 In the **Select Study** tree, select **General Studies > Frequency Domain**.
- 6 Click  **Done**.

GLOBAL DEFINITIONS

Add a parameter for the operating frequency.

Parameters 1

- 1 In the **Model Builder** window, under **Global Definitions** click **Parameters 1**.
- 2 In the **Settings** window for **Parameters**, locate the **Parameters** section.
- 3 In the table, enter the following settings:

Name	Expression	Value	Description
frq	c_const/0.03[m]	9.9931E9 1/s	Operating frequency

STUDY 1

Step 1: Frequency Domain

Define the study frequency ahead of performing any frequency-dependent operation such as building mesh. The physics-controlled mesh uses the highest frequency value in the specified range.

- 1 In the **Model Builder** window, under **Study 1** click **Step 1: Frequency Domain**.
- 2 In the **Settings** window for **Frequency Domain**, locate the **Study Settings** section.
- 3 In the **Frequencies** text field, type range $(0.9*frq, (1.5*frq - (0.9*frq))/10, 1.5*frq)$.

GEOMETRY 1

The geometry is essentially a cylinder.

Cylinder 1 (cyl1)

- 1 In the **Geometry** toolbar, click  **Cylinder**.
- 2 In the **Settings** window for **Cylinder**, locate the **Size and Shape** section.
- 3 In the **Radius** text field, type 0.01.
- 4 In the **Height** text field, type 0.1.

5 Click  **Build Selected**.

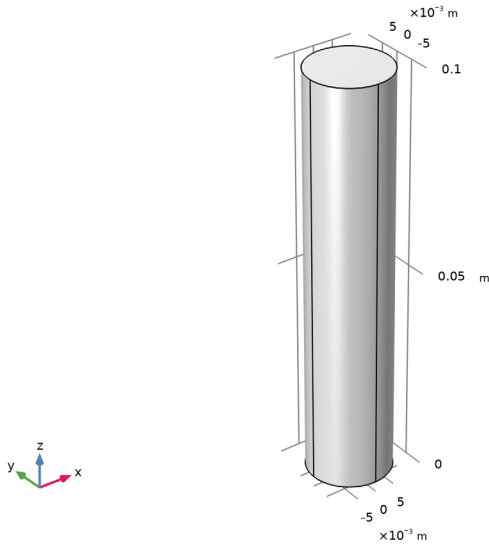

6 Click the  **Wireframe Rendering** button in the **Graphics** toolbar.

You need to add a reference direction for the port polarization. Add a couple of lines on the cylinder end to generate extra vertices. This is done in a work plane.

Work Plane 1 (wp1)

1 In the **Geometry** toolbar, click  **Work Plane**.

2 In the **Settings** window for **Work Plane**, locate the **Plane Definition** section.

3 In the **z-coordinate** text field, type 0.1.

Work Plane 1 (wp1) > Plane Geometry

In the **Model Builder** window, click **Plane Geometry**.

Work Plane 1 (wp1) > Line Segment 1 (ls1)

1 In the **Work Plane** toolbar, click  **More Primitives** and choose **Line Segment**.

2 In the **Settings** window for **Line Segment**, locate the **Starting Point** section.



3 From the **Specify** list, choose **Coordinates**.

4 Locate the **Endpoint** section. From the **Specify** list, choose **Coordinates**.

5 Locate the **Starting Point** section. In the **yw** text field, type 0.01.

6 Locate the **Endpoint** section. In the **yw** text field, type -0.01.

Work Plane 1 (wpl) > Rotate 1 (rot1)

- 1 In the **Work Plane** toolbar, click  **Transforms** and choose **Rotate**.
- 2 Select the object **Is1** only.
- 3 In the **Settings** window for **Rotate**, locate the **Rotation** section.
- 4 In the **Angle** text field, type 45 135.
- 5 Click  **Build Selected**.

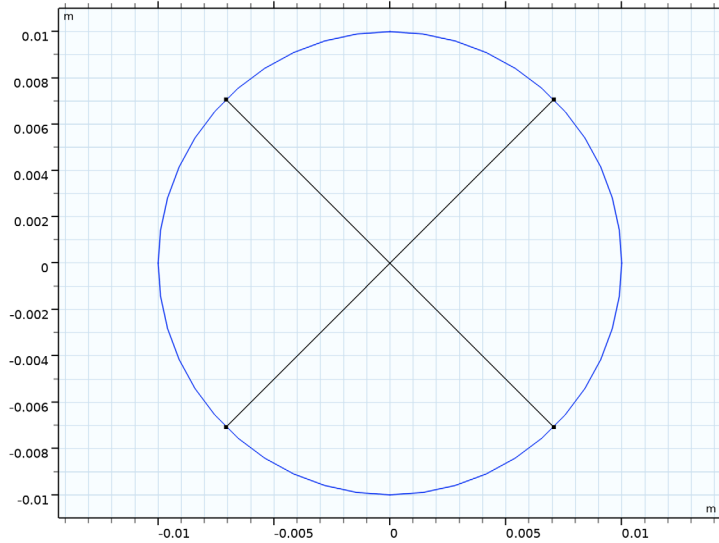

Ignore Edges 1 (ige1)

- 1 In the **Model Builder** window, right-click **Geometry 1** and choose **Virtual Operations > Ignore Edges**.

2 On the object **fin**, select Edges 7, 8, 13, and 14 only.

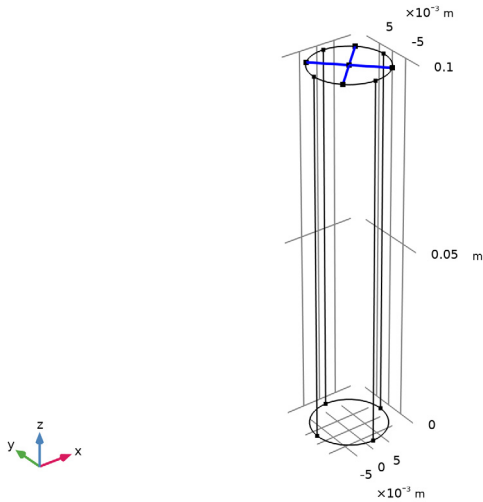

3 In the **Settings** window for **Ignore Edges**, locate the **Input** section.

4 Clear the **Ignore adjacent vertices** checkbox.

5 In the **Geometry** toolbar, click  **Build All**.

MATERIALS

Next, add a material for the interior (air) of the waveguide.

Material 1 (mat1)

1 In the **Model Builder** window, under **Component 1 (comp1)** right-click **Materials** and choose **Blank Material**.

2 In the **Settings** window for **Material**, locate the **Material Contents** section.

3 In the table, enter the following settings:

Property	Variable	Value	Unit	Property group
Relative permittivity	epsilon _{nr_} iso ; epsilon _{nrii} = epsilon _{nr_} iso, epsilon _{nrij} = 0	1		Basic
Relative permeability	mu _{r_} iso ; mu _{rii} = mu _{r_} iso, mu _{rij} = 0	1		Basic
Electric conductivity	sigma _{iso} ; sigma _{ii} = sigma _{iso} , sigma _{ij} = 0	0	S/m	Basic

ELECTROMAGNETIC WAVES, FREQUENCY DOMAIN (EMW)

Set up one inport and three outputs.

Port 1

1 In the **Physics** toolbar, click  **Boundaries** and choose **Port**.

2 Select Boundary 3 only.

It might be easier to select the correct boundary by using the **Selection List** window. To open this window, in the **Home** toolbar click **Windows** and choose **Selection List**. (If you are running the cross-platform desktop, you find **Windows** in the main menu.)

3 In the **Settings** window for **Port**, locate the **Port Properties** section.

4 From the **Type of port** list, choose **Circular**.

Circular Port Reference Axis 1

1 In the **Physics** toolbar, click  **Attributes** and choose **Circular Port Reference Axis**.

2 In the **Settings** window for **Circular Port Reference Axis**, locate the **Point Selection** section.

3 Click  **Clear Selection**.

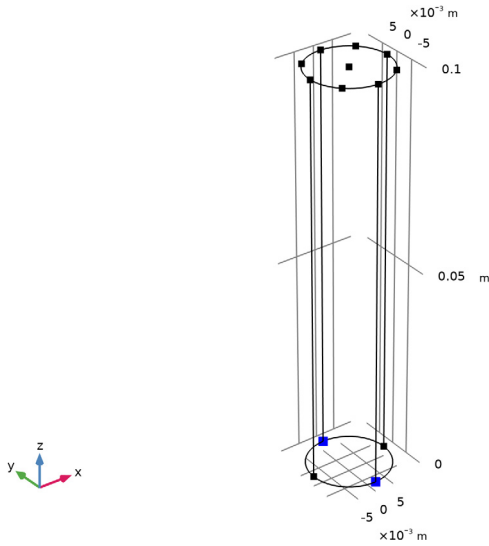

4 Select Points 5 and 8 only.



Port 2

- 1 In the **Physics** toolbar, click  **Boundaries** and choose **Port**.
- 2 Select Boundary 3 only.
- 3 In the **Settings** window for **Port**, locate the **Port Properties** section.
- 4 From the **Type of port** list, choose **Circular**.

Circular Port Reference Axis 1

- 1 In the **Physics** toolbar, click  **Attributes** and choose **Circular Port Reference Axis**.
- 2 In the **Settings** window for **Circular Port Reference Axis**, locate the **Point Selection** section.
- 3 Click  **Clear Selection**.

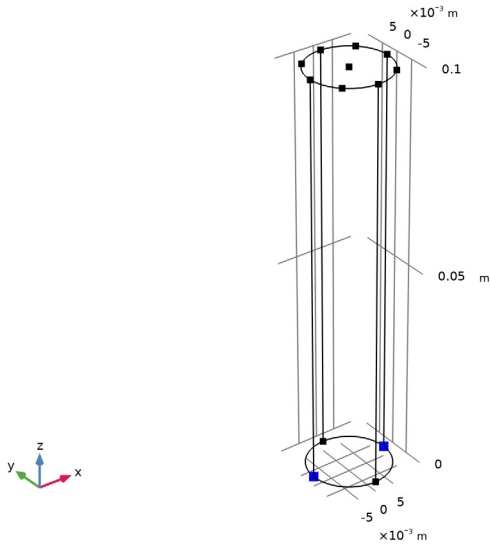

4 Select Points 1 and 12 only.



Port 3

- 1 In the **Physics** toolbar, click  **Boundaries** and choose **Port**.
- 2 Select Boundary 4 only.
- 3 In the **Settings** window for **Port**, locate the **Port Properties** section.
- 4 From the **Type of port** list, choose **Circular**.

Circular Port Reference Axis 1

- 1 In the **Physics** toolbar, click  **Attributes** and choose **Circular Port Reference Axis**.
- 2 In the **Settings** window for **Circular Port Reference Axis**, locate the **Point Selection** section.
- 3 Click  **Clear Selection**.

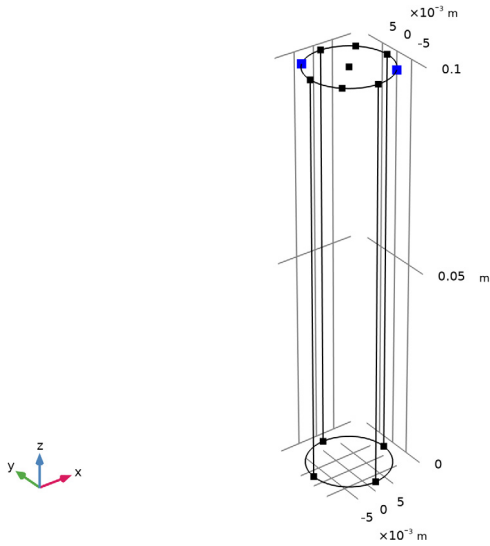

4 Select Points 4 and 10 only.



Port 4

- 1 In the **Physics** toolbar, click  **Boundaries** and choose **Port**.
- 2 Select Boundary 4 only.
- 3 In the **Settings** window for **Port**, locate the **Port Properties** section.
- 4 From the **Type of port** list, choose **Circular**.

Circular Port Reference Axis 1

- 1 In the **Physics** toolbar, click  **Attributes** and choose **Circular Port Reference Axis**.
- 2 In the **Settings** window for **Circular Port Reference Axis**, locate the **Point Selection** section.
- 3 Click  **Clear Selection**.

4 Select Points 3 and 11 only.

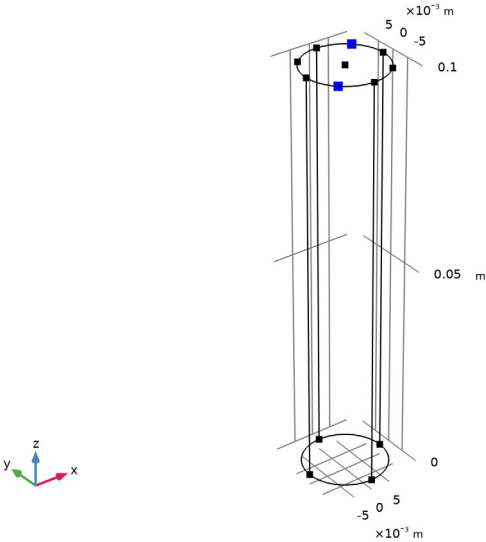

MESH I

In the **Model Builder** window, under **Component I (comp1)** right-click **Mesh I** and choose **Build All**.

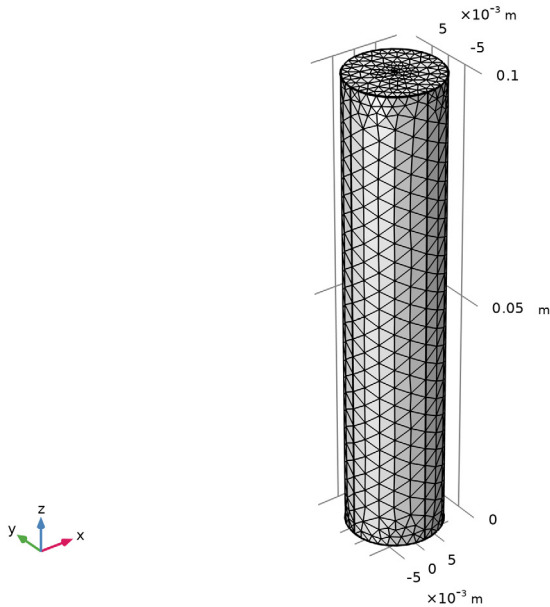

STUDY I

Step 1: Frequency Domain

In the **Study** toolbar, click  **Compute**.

RESULTS

Electric Field (emw)

Inspect the electric field norm.

freq(11)=14.99 GHz

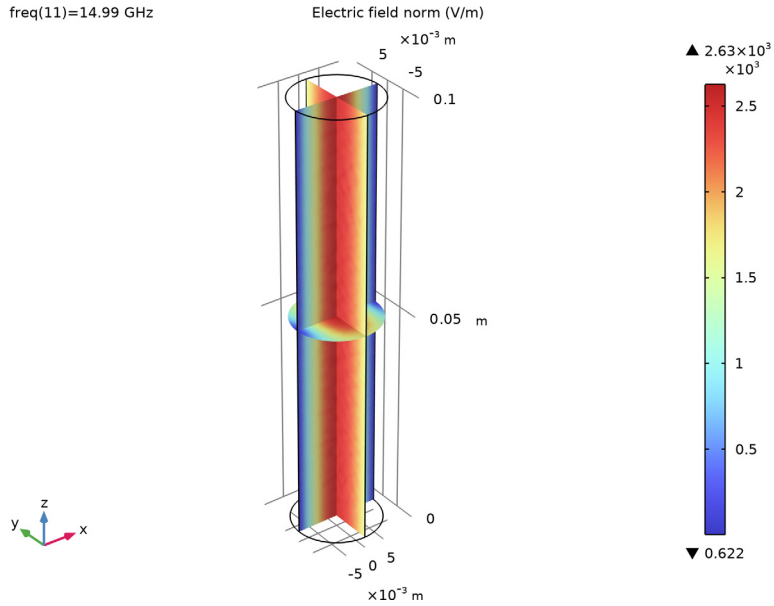

Next, inspect the S-parameters representing transmission.

S-Parameter (emw)

As expected, the transmitted energy is evenly divided between the output modes (Figure 3).

Smith Plot (emw)

In the **Model Builder** window, click **Smith Plot (emw)**.

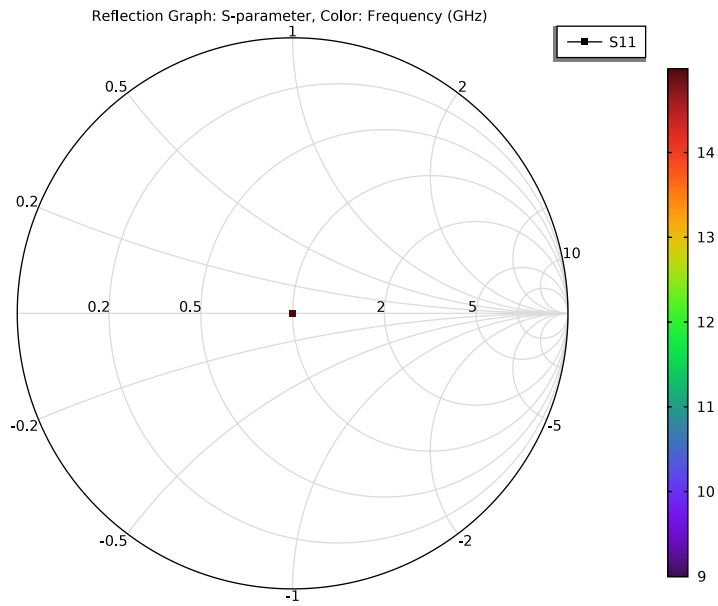

Electric Field, Logarithmic (emw)

In the **Model Builder** window, click **Electric Field, Logarithmic (emw)**.

freq(11)=14.99 GHz

Surface: 1 (1) Surface: Electric field norm (V/m)

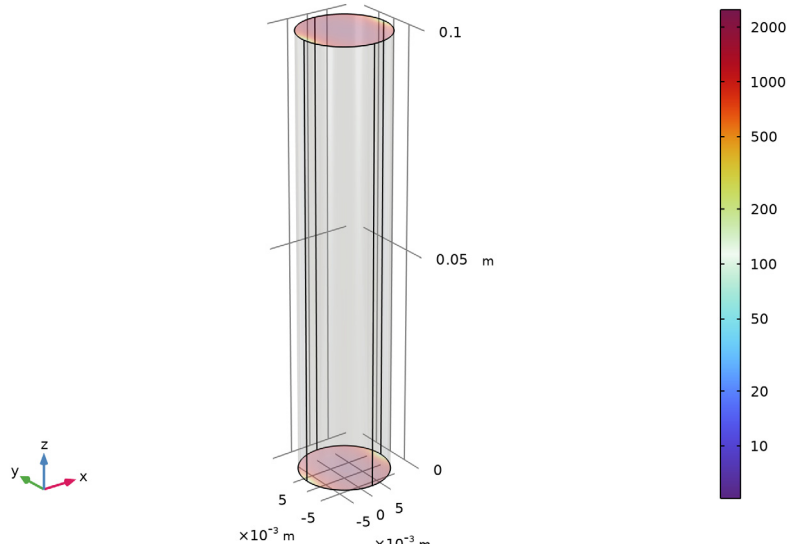

Port 1



- 1 In the **Results** toolbar, click  **3D Plot Group**.
- 2 In the **Settings** window for **3D Plot Group**, type Port 1 in the **Label** text field.

Surface 1

- 1 Right-click **Port 1** and choose **Surface**.
- 2 In the **Settings** window for **Surface**, click **Replace Expression** in the upper-right corner of the **Expression** section. From the menu, choose **Component 1 (comp1) > Electromagnetic Waves, Frequency Domain > Ports > emw.normtEmode_1 - Port tangential electric mode field norm - V/m**.

Arrow Surface 1

- 1 In the **Model Builder** window, right-click **Port 1** and choose **Arrow Surface**.
- 2 In the **Settings** window for **Arrow Surface**, click **Replace Expression** in the upper-right corner of the **Expression** section. From the menu, choose **Component 1 (comp1) > Electromagnetic Waves, Frequency Domain > Ports > emw.tEmodex_1,...,emw.tEmodex_1 - Port tangential electric mode field**.
- 3 Locate the **Arrow Positioning** section. In the **Number of arrows** text field, type 1000.

- 4 Locate the **Coloring and Style** section. From the **Color** list, choose **Black**.
- 5 In the **Port 1** toolbar, click  **Plot**.
- 6 Click  **Plot**.

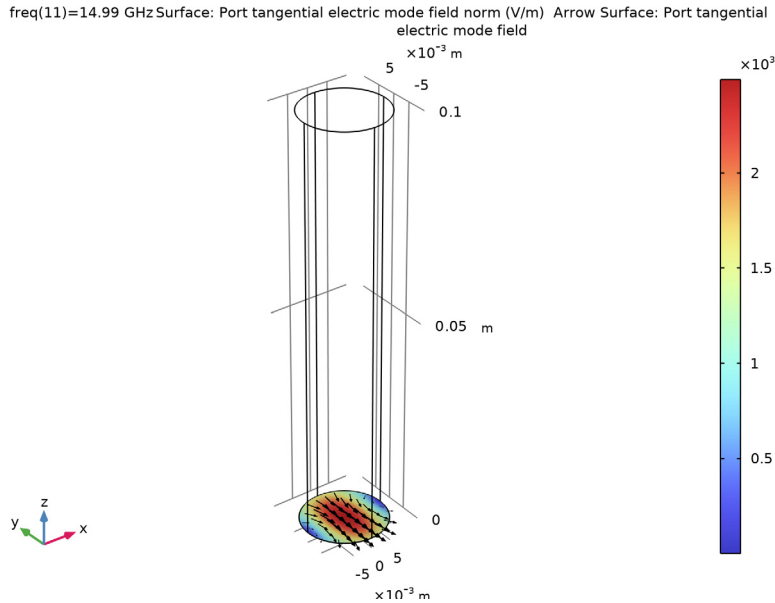

Port 2

- 1 Right-click **Port 1** and choose **Duplicate**.
- 2 In the **Settings** window for **3D Plot Group**, type Port_2 in the **Label** text field.

Surface 1

- 1 In the **Model Builder** window, expand the **Port 2** node, then click **Surface 1**.
- 2 In the **Settings** window for **Surface**, locate the **Expression** section.
- 3 In the **Expression** text field, type `emw.normtEmode_2`.

Arrow Surface 1

- 1 In the **Model Builder** window, click **Arrow Surface 1**.
- 2 In the **Settings** window for **Arrow Surface**, locate the **Expression** section.
- 3 In the **X-component** text field, type `emw.tEmodex_2`.
- 4 In the **Y-component** text field, type `emw.tEmodey_2`.
- 5 In the **Z-component** text field, type `emw.tEmodez_2`.

6 In the **Port 2** toolbar, click  **Plot**.

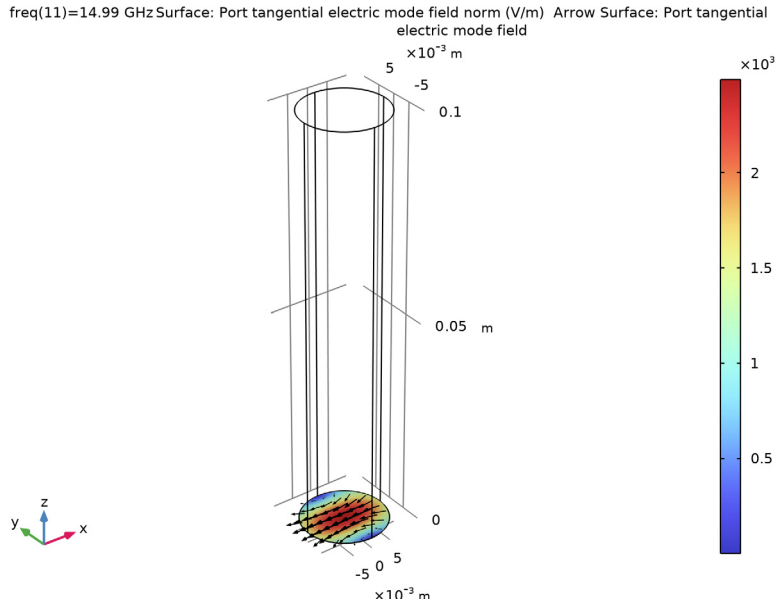

Port 3

- 1 In the **Model Builder** window, right-click **Port 2** and choose **Duplicate**.
- 2 In the **Settings** window for **3D Plot Group**, type Port 3 in the **Label** text field.

Surface 1

- 1 In the **Model Builder** window, expand the **Port 3** node, then click **Surface 1**.
- 2 In the **Settings** window for **Surface**, locate the **Expression** section.
- 3 In the **Expression** text field, type `emw.normtEmode_3`.

Arrow Surface 1

- 1 In the **Model Builder** window, click **Arrow Surface 1**.
- 2 In the **Settings** window for **Arrow Surface**, locate the **Expression** section.
- 3 In the **X-component** text field, type `emw.tEmodex_3`.
- 4 In the **Y-component** text field, type `emw.tEmodey_3`.
- 5 In the **Z-component** text field, type `emw.tEmodez_3`.

6 In the **Port 3** toolbar, click  **Plot**.

freq(11)=14.99 GHz Surface: Port tangential electric mode field norm (V/m) Arrow Surface: Port tangential electric mode field

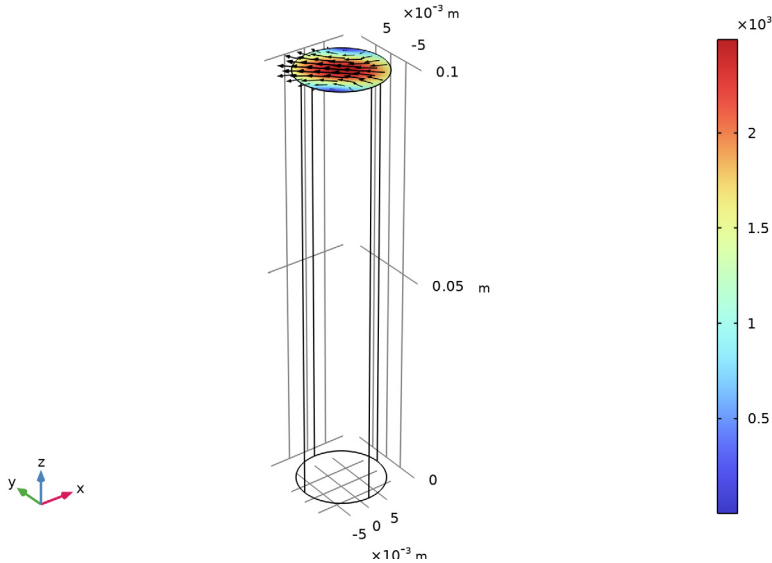

Port 4

- 1 In the **Model Builder** window, right-click **Port 3** and choose **Duplicate**.
- 2 In the **Settings** window for **3D Plot Group**, type Port 4 in the **Label** text field.

Surface 1

- 1 In the **Model Builder** window, expand the **Port 4** node, then click **Results > Port 3 > Surface 1**.
- 2 In the **Settings** window for **Surface**, locate the **Expression** section.
- 3 In the **Expression** text field, type `emw.normtEmode_4`.

Arrow Surface 1

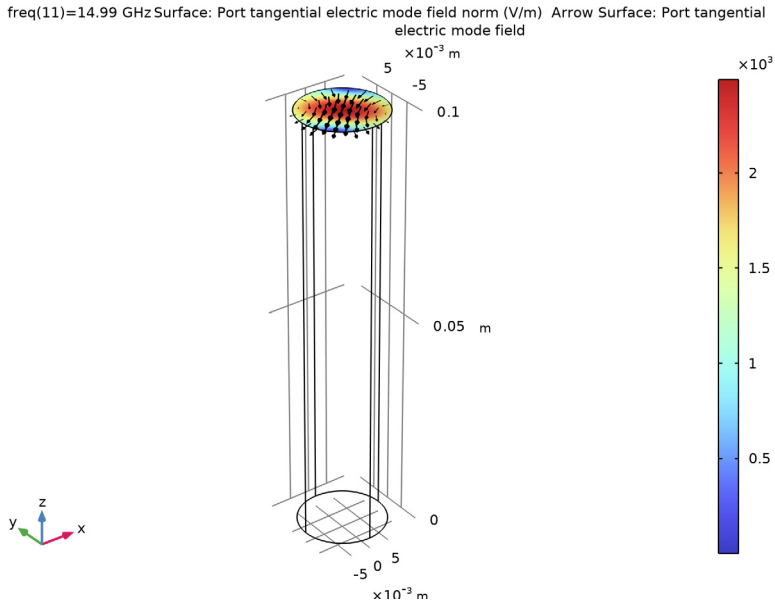

- 1 In the **Model Builder** window, under **Results > Port 4** click **Arrow Surface 1**.
- 2 In the **Settings** window for **Arrow Surface**, locate the **Expression** section.
- 3 In the **X-component** text field, type `emw.tEmode_x_4`.
- 4 In the **Y-component** text field, type `emw.tEmode_y_4`.
- 5 In the **Z-component** text field, type `emw.tEmode_z_4`.

6 In the **Port 4** toolbar, click  **Plot**.



Next, display numerical values for the transmission at the highest frequency.

Global Evaluation 2

- 1 In the **Results** toolbar, click  **Global Evaluation**.
- 2 In the **Settings** window for **Global Evaluation**, locate the **Data** section.
- 3 From the **Parameter selection (freq)** list, choose **Last**.
- 4 Click **Replace Expression** in the upper-right corner of the **Expressions** section. From the menu, choose **Component 1 (comp1) > Electromagnetic Waves, Frequency Domain > Ports > S-parameter, dB - dB > emw.S31 dB - S31**.
- 5 Click  **Evaluate**.

Global Evaluation 3

- 1 In the **Results** toolbar, click  **Global Evaluation**.
- 2 In the **Settings** window for **Global Evaluation**, locate the **Data** section.
- 3 From the **Parameter selection (freq)** list, choose **Last**.
- 4 Click **Replace Expression** in the upper-right corner of the **Expressions** section. From the menu, choose **Component 1 (comp1) > Electromagnetic Waves, Frequency Domain > Ports > S-parameter, dB - dB > emw.S41 dB - S41**.

5 Click  Evaluate.

As expected, the result is about -3 dB for both modes.