



Model created in COMSOL Multiphysics 6.4

Modeling of a Mobile Device Antenna

Introduction

Electrical components in wireless communication systems are designed to be small and light for portability and productivity while maintaining decent performance and efficiency. Antennas are essential components in mobile devices and are required to fit in the limited space allowed by industrial specifications. To fulfill this requirement, a planar inverted-F antenna (PIFA) is common and a popular choice for miniaturized antennas in cellphones. The PIFA design can be tuned and extended to cover multiple frequency bands from cellphones, Wi-Fi, and Bluetooth[®]. The antenna in this introductory example is tuned only for the Advanced Wireless Services (AWS) band downlink frequency range. The impedance matching properties of the antenna are calculated in terms of S-parameters and the far-field radiation pattern is simulated.

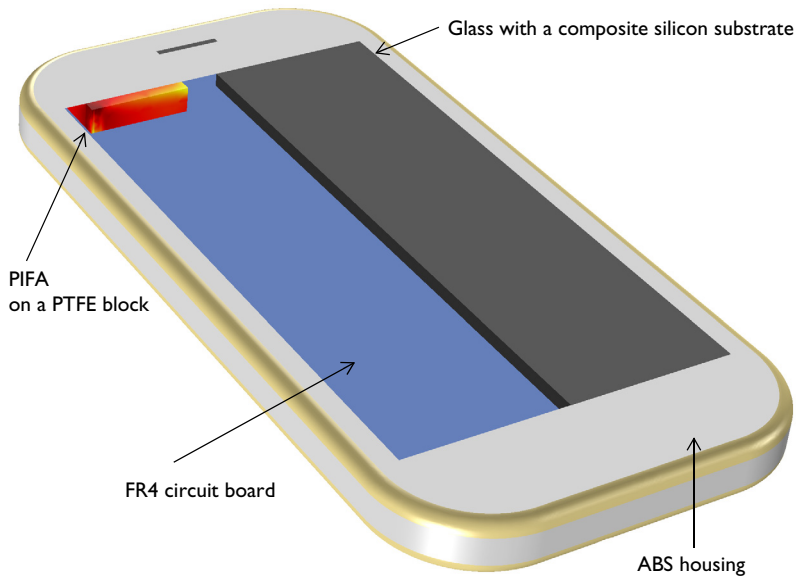

Figure 1: A simple PIFA on an FR4 circuit board is enclosed by an ABS package. The front part of the enclosure contains the combination of glass and a composite silicon substrate that form a touchscreen display. The surrounding air domain and perfectly matched layers, which are required for the simulation, are not included in this figure.

Model Definition

The AWS band downlink frequency range is from 2.11 GHz to 2.155 GHz. At this frequency range, the metal part of the antenna can be modeled using perfect electric

conductor (PEC) boundaries. The losses on the metal surfaces are negligible because of the high conductivity of the copper.

The FR4 circuit board with a ground plane is inserted inside an RF lossless acrylonitrile butadiene styrene (ABS) enclosure. The antenna with the cellphone mock-up case is modeled in a spherical air domain, which is enclosed by perfectly matched layers (PML) that absorb all outgoing radiation from the antenna.

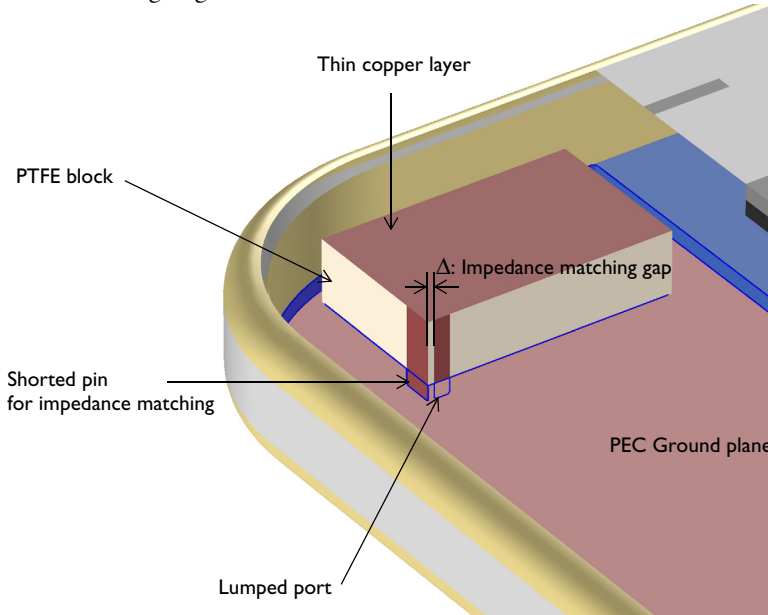

Figure 2: Zoomed view of the PIFA. It consists of a radiating part, a feeding strip and an impedance matching strip shorted to the ground plane.

A lumped port with a reference impedance of 50Ω is used to excite the antenna and evaluate the input impedance. The lumped port is assigned between two metallic boundaries: the ground plane of the FR4 board and a vertical feeding strip (Figure 2). Another strip shorted to the ground plane is added adjacent to the feeding strip for impedance matching. The distance Δ , the impedance matching gap, plays an important role for matching the antenna to the reference impedance.

Results and Discussion

Figure 3 shows the default E-field norm on the xy -plane where the height of the plane is adjusted to visualize the plot on the top surface of the PIFA. The field distribution plot indicates that the electric field is strong at one of the top metallic surfaces far from the

feeding point. This resembles the field distribution of a quarter-wave monopole antenna, which the PIFA evolved from.

The polar-formatted far-field radiation pattern of the antenna is shown in [Figure 5](#). Because the antenna is miniaturized and placed on one corner of the ground plane, this azimuthal radiation pattern is not omnidirectional any more. The antenna gain on the xy -plane varies from -6 dBi to 2 dBi.

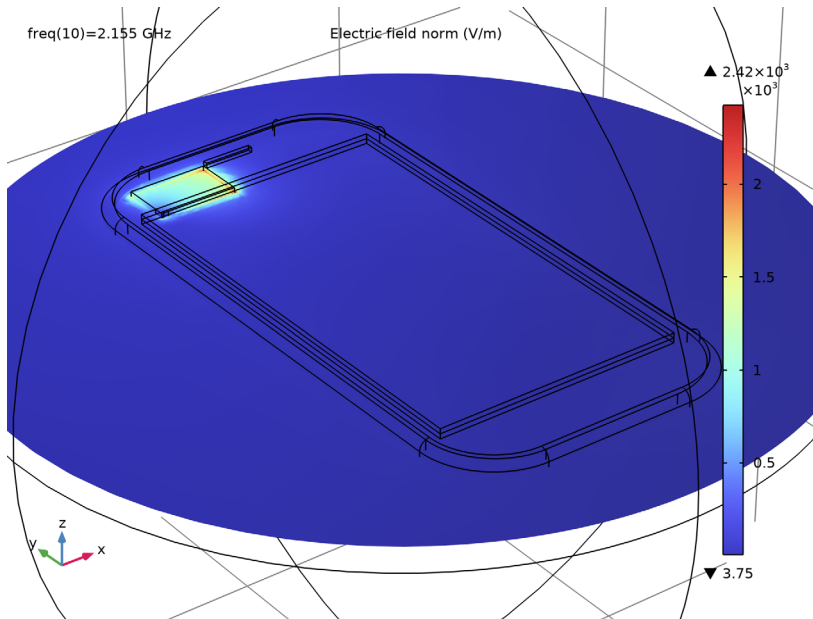

Figure 3: E-field norm distribution on the top of the PIFA.

The S-parameters in the given frequency range are plotted in [Figure 4](#). All calculated S_{11} values are below -10 dB, which is a voltage standing wave ratio (VSWR) of less than 2:1. This ratio describes how well the antenna input impedance is matched to the 50Ω reference impedance typical in common measurement systems such as network analyzers.

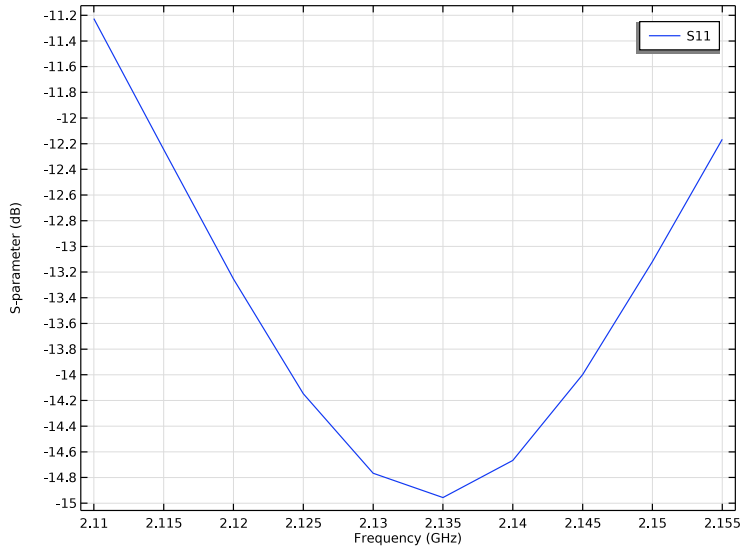

Figure 4: S -parameters (S_{11}) in the advanced wireless services (AWS) downlink frequency range.

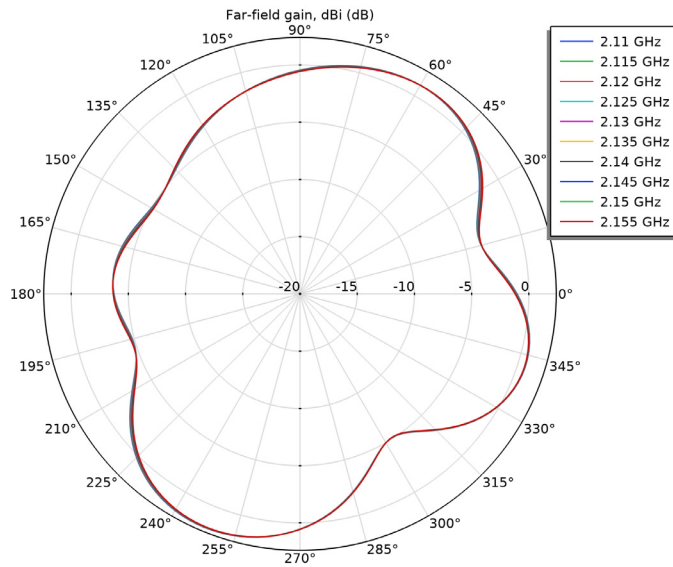

Figure 5: Antenna gain pattern on the xy -plane.

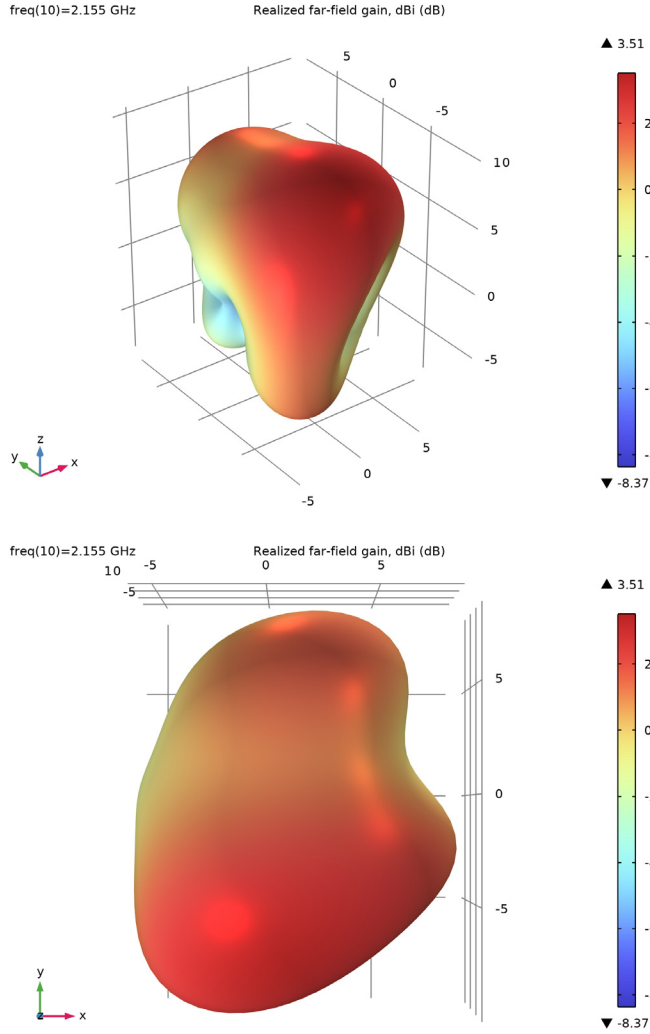

Figure 6: 3D far-field radiation pattern shown from two different angles.

The 2D far-field radiation pattern may not be sufficient to show the maximum radiation and nulls. Therefore, it is a good practice to review 3D radiation patterns as well shown in [Figure 6](#).

Application Library path: RF_Module/Antennas/pifa_handheld



Modeling Instructions

From the **File** menu, choose **New**.

NEW

In the **New** window, click  **Model Wizard**.

MODEL WIZARD

- 1 In the **Model Wizard** window, click  **3D**.
- 2 In the **Select Physics** tree, select **Radio Frequency > Electromagnetic Waves, Frequency Domain (emw)**.
- 3 Click **Add**.
- 4 Click  **Study**.
- 5 In the **Select Study** tree, select **General Studies > Frequency Domain**.
- 6 Click  **Done**.

STUDY I

Step 1: Frequency Domain

Set the simulation frequency to the range of the advanced wireless services (AWS) downlink ahead of performing any frequency-dependent operation such as building mesh. The physics-controlled mesh uses the highest frequency value in the specified range.





- 1 In the **Model Builder** window, under **Study I** click **Step 1: Frequency Domain**.
- 2 In the **Settings** window for **Frequency Domain**, locate the **Study Settings** section.
- 3 In the **Frequencies** text field, type range (2.11 [GHz] , 5 [MHz] , 2.155 [GHz]).

GEOMETRY I

- 1 In the **Model Builder** window, under **Component 1 (comp1)** click **Geometry 1**.
- 2 In the **Settings** window for **Geometry**, locate the **Units** section.
- 3 From the **Length unit** list, choose **mm**.

First, import a mobile device package design created with the Design Module.

Import 1 (imp1)

- 1 In the **Geometry** toolbar, click  **Import**.
- 2 In the **Settings** window for **Import**, locate the **Source** section.
- 3 Click  **Browse**.
- 4 Browse to the model's Application Libraries folder and double-click the file `pifa_handheld.mphbin`.
- 5 Click  **Import**.
- 6 Click the  **Wireframe Rendering** button in the **Graphics** toolbar.
Choose wireframe rendering in order to see the interior of the package.

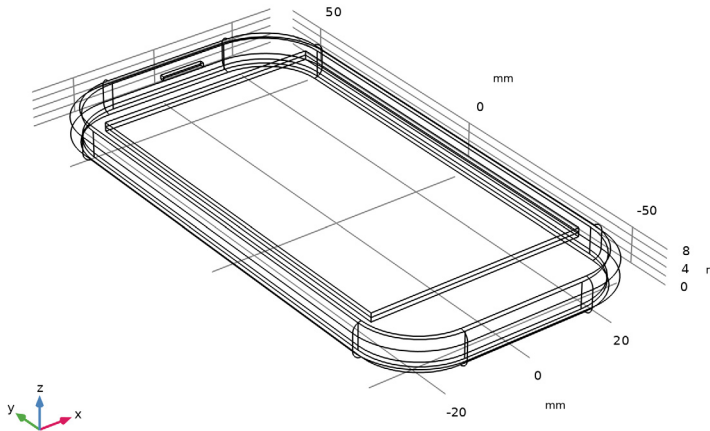

Add a PTFE block where the planar inverted-F antenna (PIFA) will be placed.

PTFE antenna body

- 1 In the **Geometry** toolbar, click  **Block**.
- 2 In the **Settings** window for **Block**, type `PTFE antenna body` in the **Label** text field.
- 3 Locate the **Size and Shape** section. In the **Width** text field, type `15.9`.
- 4 In the **Depth** text field, type `10`.
- 5 In the **Height** text field, type `4`.
- 6 Locate the **Position** section. In the **x** text field, type `-20`.
- 7 In the **z** text field, type `2`.

8 In the **y** text field, type 45.

Add two strips for the feeding and matching parts of the PIFA.

Work Plane 1 (wp1)

1 In the **Geometry** toolbar, click  **Work Plane**.

2 In the **Settings** window for **Work Plane**, locate the **Plane Definition** section.

3 From the **Plane** list, choose **xz-plane**.

4 In the **y-coordinate** text field, type 45.

5 Click  **Go to Plane Geometry**.

Work Plane 1 (wp1) > Rectangle 1 (r1)

1 In the **Work Plane** toolbar, click  **Rectangle**.

2 Click the  **Zoom Extents** button in the **Graphics** toolbar.

3 In the **Settings** window for **Rectangle**, locate the **Size and Shape** section.

4 In the **Height** text field, type 5.

5 Locate the **Position** section. In the **xw** text field, type -19.6.

6 In the **yw** text field, type 1.

7 Click  **Build Selected**.

Work Plane 2 (wp2)

1 In the **Model Builder** window, right-click **Geometry 1** and choose **Work Plane**.

2 In the **Settings** window for **Work Plane**, locate the **Plane Definition** section.

3 From the **Plane type** list, choose **Face parallel**.

4 On the object **blk1**, select Boundary 2 only.

It might be easier to select the correct boundary by using the **Selection List** window. To open this window, in the **Home** toolbar click **Windows** and choose **Selection List**. (If you are running the cross-platform desktop, you find **Windows** in the main menu.)

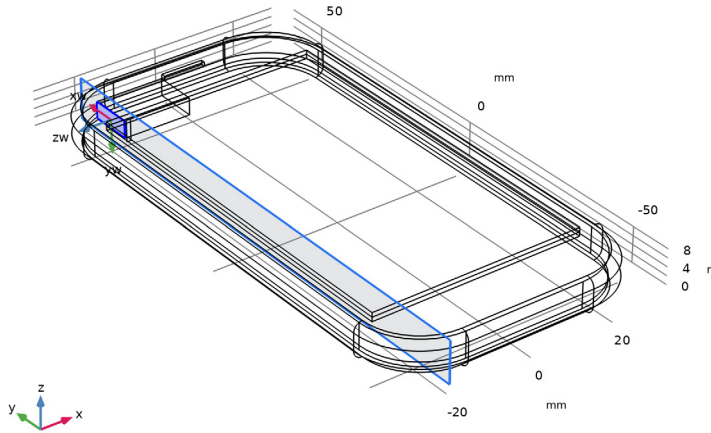

5 Click  **Go to Plane Geometry**.

Work Plane 2 (wp2) > Rectangle 1 (r1)

1 In the **Work Plane** toolbar, click  **Rectangle**.

2 In the **Settings** window for **Rectangle**, locate the **Size and Shape** section.

3 In the **Width** text field, type 2.

4 In the **Height** text field, type 5.

5 Locate the **Position** section. In the **xw** text field, type -5.

6 In the **yw** text field, type -2.

7 Click  **Build Selected**.

Work Plane 2 (wp2)

1 In the **Model Builder** window, under **Component 1 (comp1) > Geometry 1** click **Work Plane 2 (wp2)**.

2 In the **Settings** window for **Work Plane**, click  **Build All Objects**.

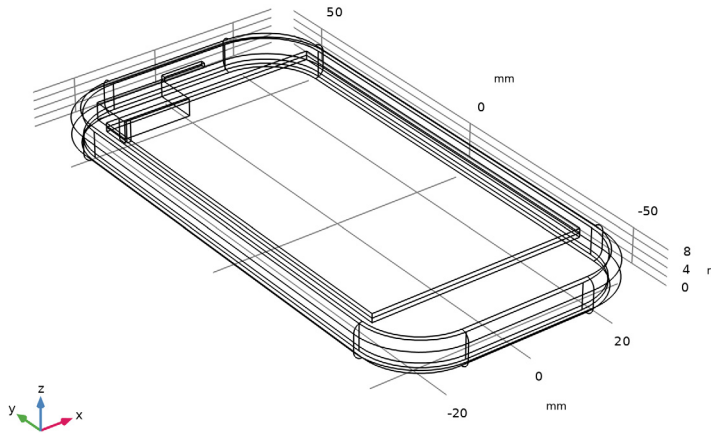



Finish the geometry definition by adding a sphere for a surrounding air domain, where you will configure layer settings to define perfectly matched layers later on.

Sphere 1 (sph1)

- 1 In the **Geometry** toolbar, click  **Sphere**.
- 2 In the **Settings** window for **Sphere**, locate the **Size** section.
- 3 In the **Radius** text field, type 100.
- 4 Click to expand the **Layers** section. In the table, enter the following settings:

Layer name	Thickness (mm)
Layer 1	20

5 In the **Geometry** toolbar, click  **Build All**.

6 Click the  **Zoom Out** button in the **Graphics** toolbar.

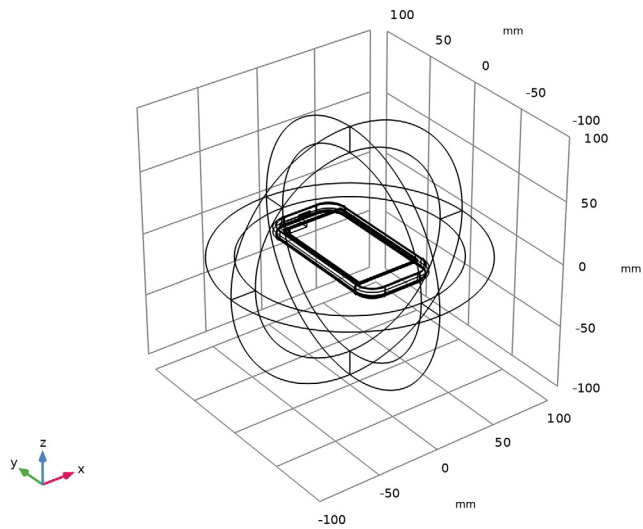

DEFINITIONS

Perfectly Matched Layer I (pmlI)

1 In the **Definitions** toolbar, click  **Perfectly Matched Layer**.

2 Select Domains 1–4 and 13–16 only.

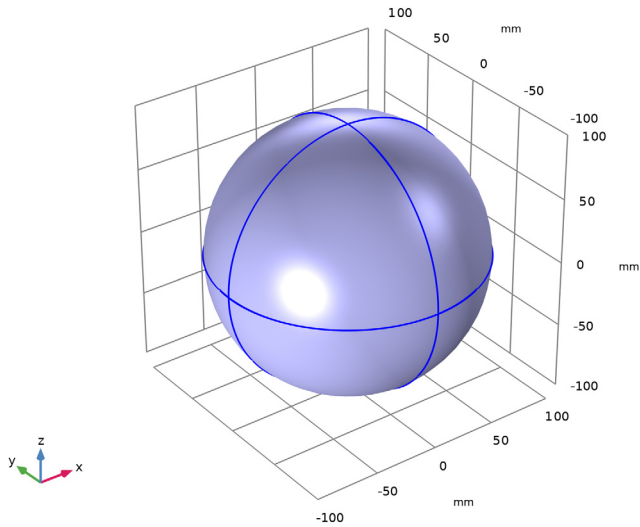

These are all of the outermost domains of the sphere.

3 In the **Settings** window for **Perfectly Matched Layer**, locate the **Geometry** section.

4 From the **Type** list, choose **Spherical**.

Suppress some boundaries to get a better view when setting up materials, physics and mesh.

Hide for Physics 1

1 In the **Model Builder** window, right-click **View 1** and choose **Hide for Physics**.

2 In the **Settings** window for **Hide for Physics**, locate the **Geometric Entity Selection** section.

3 From the **Geometric entity level** list, choose **Boundary**.

4 Select Boundaries 6, 10, 69, 72, and 74 only.

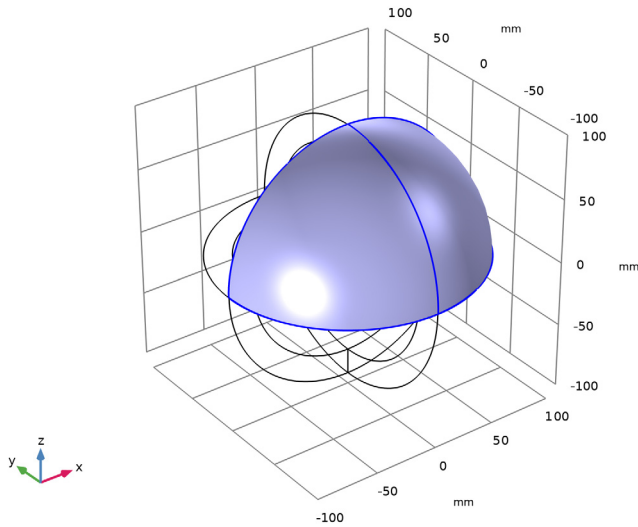

ADD MATERIAL

- 1 In the **Materials** toolbar, click  **Add Material** to open the **Add Material** window.
- 2 Go to the **Add Material** window.
- 3 In the tree, select **Built-in > Air**.
- 4 Click the **Add to Component** button in the window toolbar.

MATERIALS

Air (mat1)

The entire domain is set to air. Override this setting in certain parts with different materials one by one.

ADD MATERIAL

- 1 Go to the **Add Material** window.
- 2 In the tree, select **Built-in > FR4 (Circuit Board)**.
- 3 Click the **Add to Component** button in the window toolbar.
- 4 In the tree, select **Built-in > Glass (quartz)**.
- 5 Click the **Add to Component** button in the window toolbar.
- 6 In the tree, select **Built-in > Silicon**.

7 Click the **Add to Component** button in the window toolbar.

8 In the **Materials** toolbar, click  **Add Material** to close the **Add Material** window.

MATERIALS

FR4 (Circuit Board) (mat2)

1 Click the  **Zoom In** button in the **Graphics** toolbar.

2 Select Domain 7 only.

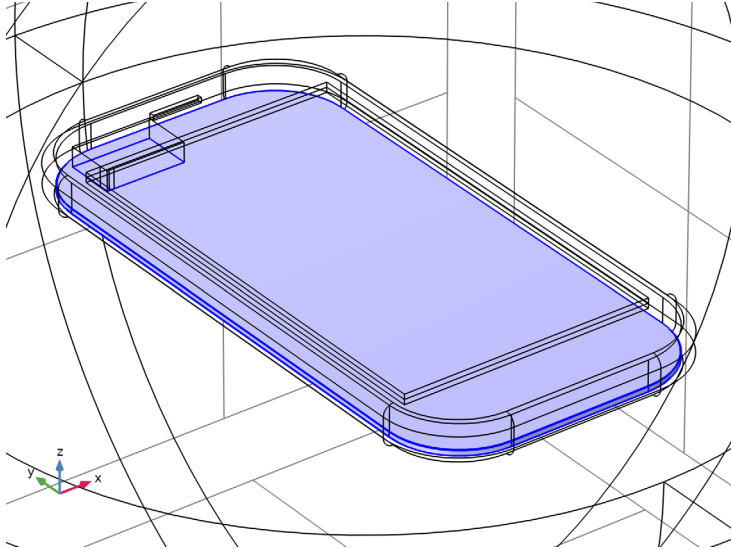

Glass (quartz) (mat3)

1 In the **Model Builder** window, click **Glass (quartz) (mat3)**.

2 Select Domain 10 only.

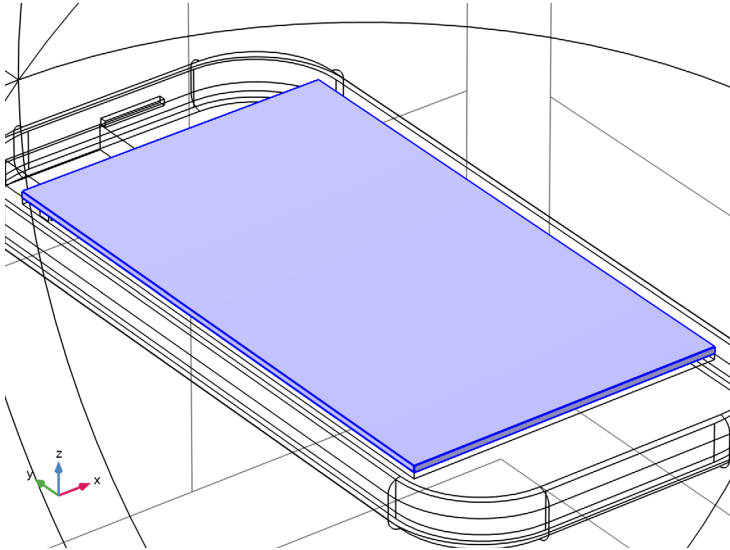

Silicon (mat4)

1 In the **Model Builder** window, click **Silicon (mat4)**.

2 Select Domain 9 only.

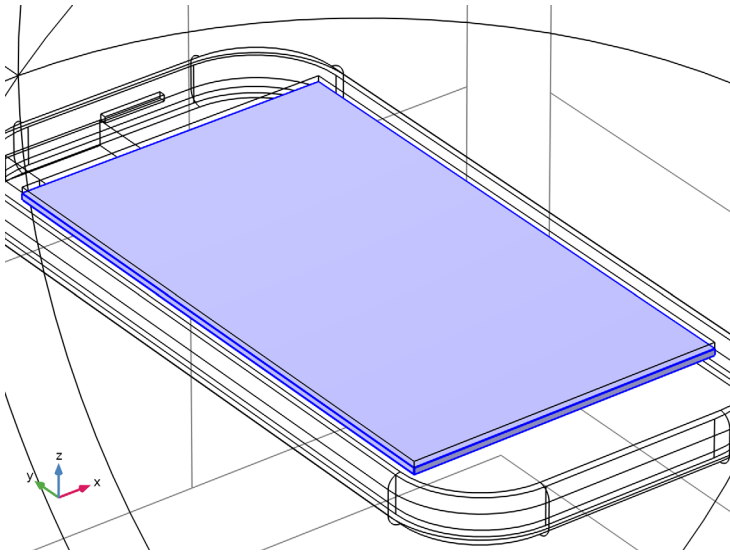

PTFE antenna block

- 1 In the **Model Builder** window, right-click **Materials** and choose **Blank Material**.
- 2 In the **Settings** window for **Material**, type PTFE antenna block in the **Label** text field.
- 3 Select Domain 11 only.

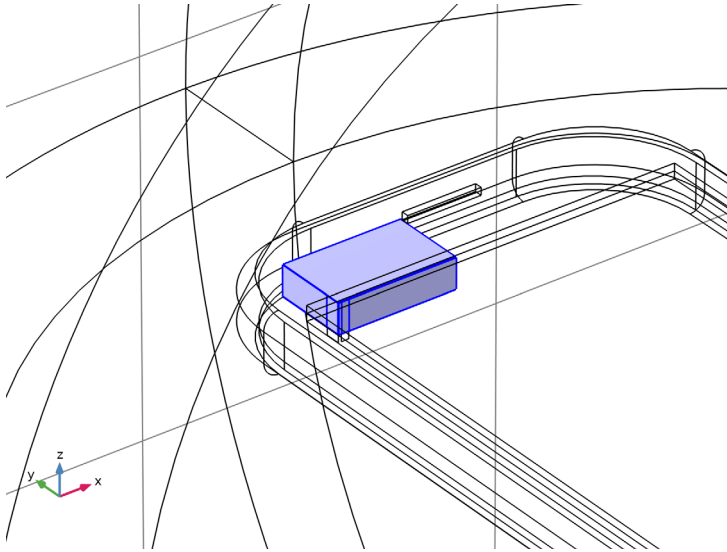

- 4 Locate the **Material Contents** section. In the table, enter the following settings:

Property	Variable	Value	Unit	Property group
Relative permittivity	epsilon _{nr_iso} ; epsilon _{nrii} = epsilon _{nr_iso} , epsilon _{nrij} = 0	2.1		Basic
Relative permeability	mu _{r_iso} ; mu _{rii} = mu _{r_iso} , mu _{rij} = 0	1		Basic
Electric conductivity	sigma _{iso} ; sigma _{ii} = sigma _{iso} , sigma _{ij} = 0	0	S/m	Basic

ABS

- 1 Right-click **Materials** and choose **Blank Material**.
- 2 In the **Settings** window for **Material**, type ABS in the **Label** text field.

3 Select Domain 6 only.

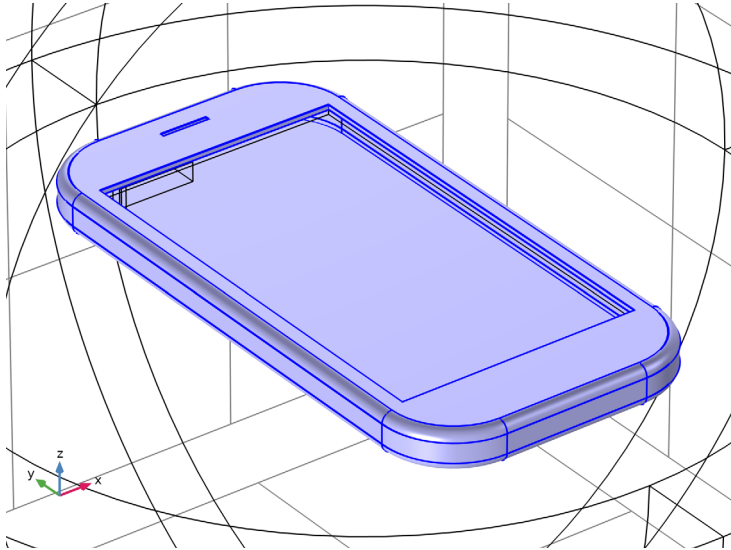

4 Locate the **Material Contents** section. In the table, enter the following settings:

Property	Variable	Value	Unit	Property group
Relative permittivity	epsilon _{nr_iso} ; epsilon _{nrii} = epsilon _{nr_iso} , epsilon _{nrij} = 0	2.1		Basic
Relative permeability	mu _{r_iso} ; mu _{rii} = mu _{r_iso} , mu _{rij} = 0	1		Basic
Electric conductivity	sigma _{iso} ; sigma _{ii} = sigma _{iso} , sigma _{ij} = 0	0	S/m	Basic

Now set up the physics. By assuming the losses on metal surfaces are negligible at the simulation frequency range, all metal parts can be modeled as perfect electric conductors (PEC).

ELECTROMAGNETIC WAVES, FREQUENCY DOMAIN (EMW)

Perfect Electric Conductor 2

- 1 In the **Physics** toolbar, click  **Boundaries** and choose **Perfect Electric Conductor**.
- 2 Select Boundaries 26, 42, 43, 46, and 50 only.

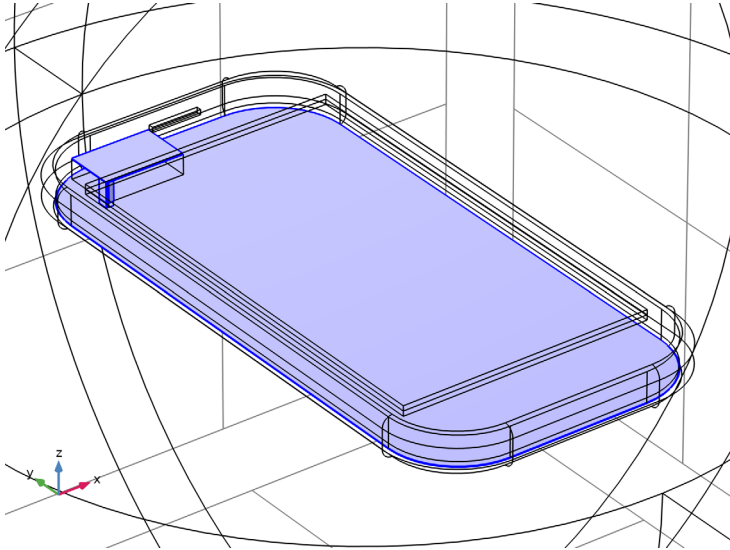

Lumped Port 1

- 1 In the **Physics** toolbar, click  **Boundaries** and choose **Lumped Port**.

2 Select Boundary 49 only.

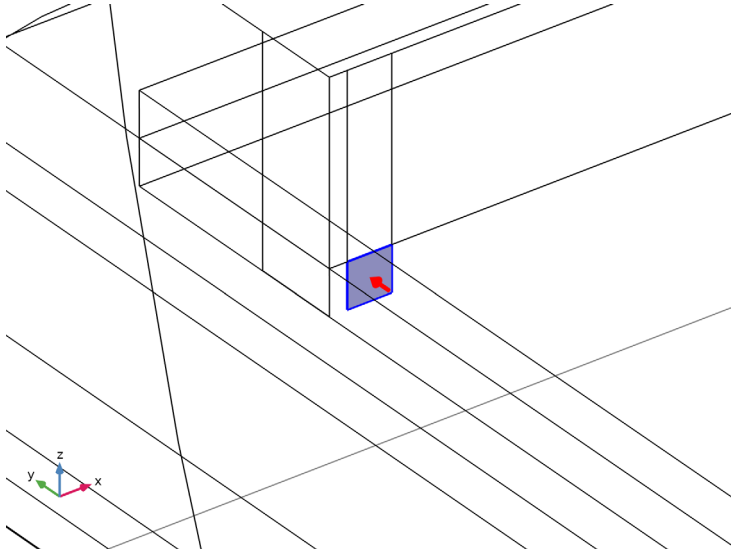

For the first port, wave excitation is **on** by default.

Far-Field Domain 1

In the **Physics** toolbar, click  **Domains** and choose **Far-Field Domain**.

MESH 1

Choose the Coarse element size to reduce the size of the problem (degrees of freedom). This will generate a less dense mesh on curved parts while the maximum element size is still forced to be smaller than 0.2 wavelengths.

- 1 In the **Model Builder** window, under **Component 1 (comp1)** click **Mesh 1**.
- 2 In the **Settings** window for **Mesh**, locate the **Physics-Controlled Mesh** section.
- 3 From the **Element size** list, choose **Coarse**.

4 Click  **Build All**.

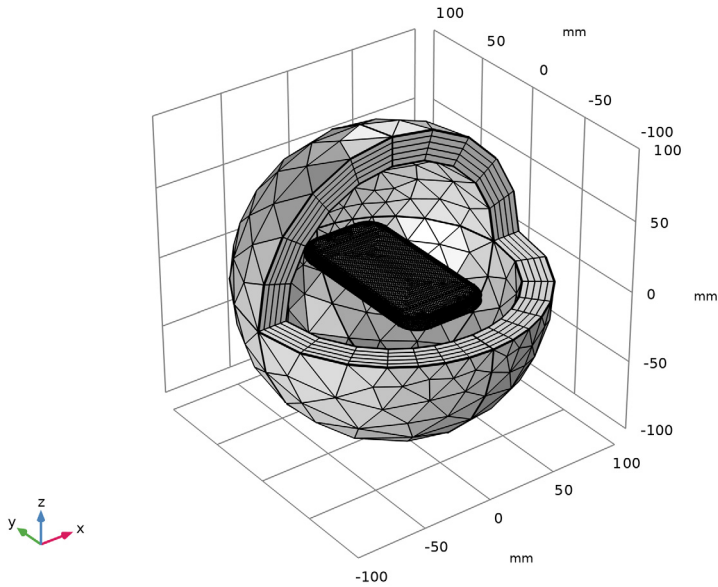

STUDY 1

Step 1: Frequency Domain

In the **Study** toolbar, click  **Compute**.

RESULTS

Electric Field (emw)

Adjust the default E-field norm multislice plot.

Multislice 1

- 1 In the **Model Builder** window, expand the **Electric Field (emw)** node, then click **Multislice 1**.
- 2 In the **Settings** window for **Multislice**, locate the **Multipane Data** section.
- 3 Find the **X-planes** subsection. In the **Planes** text field, type 0.
- 4 Find the **Y-planes** subsection. In the **Planes** text field, type 0.
- 5 Find the **Z-planes** subsection. From the **Entry method** list, choose **Coordinates**.
- 6 In the **Coordinates** text field, type 5.

7 In the **Electric Field (emw)** toolbar, click  **Plot**.

Compare the reproduced plot with [Figure 3](#).

S-Parameter (emw)

The default S-parameter plot shows the impedance matching properties. See [Figure 4](#).

Smith Plot (emw)

In the **Model Builder** window, click **Smith Plot (emw)**.

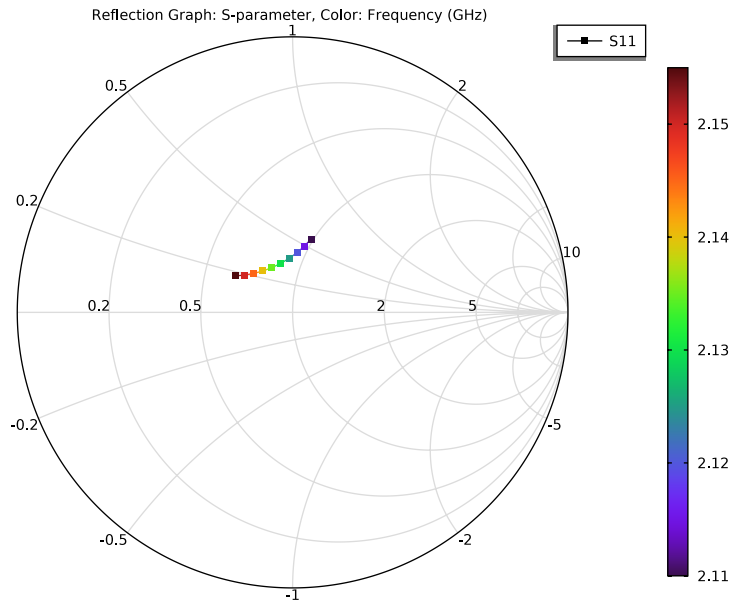

Electric Field, Logarithmic (emw)

In the **Model Builder** window, click **Electric Field, Logarithmic (emw)**.

freq(10)=2.155 GHz Surface: 1 (1) Multislice: Electric field norm (V/m) Surface: Electric field norm (V/m)

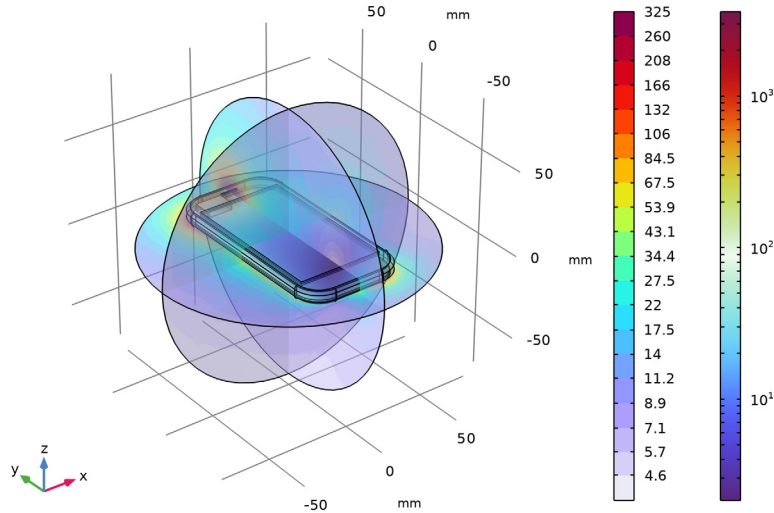

2D Far Field (emw)

Adjust the default polar plot settings to show the antenna gain pattern on the xy -plane.

Radiation Pattern I

- 1 In the **Model Builder** window, expand the **2D Far Field (emw)** node, then click **Radiation Pattern I**.
- 2 In the **Settings** window for **Radiation Pattern**, click **Replace Expression** in the upper-right corner of the **Expression** section. From the menu, choose **Component I (comp1) > Electromagnetic Waves, Frequency Domain > Far field > emw.gaindBefar - Far-field gain, dBi - dB**.



2D Far Field (emw)

- 1 In the **Model Builder** window, click **2D Far Field (emw)**.
- 2 In the **Settings** window for **Polar Plot Group**, locate the **Axis** section.
- 3 Select the **Manual axis limits** checkbox.
- 4 In the **r minimum** text field, type -20.

- 5 In the **2D Far Field (emw)** toolbar, click  **Plot**.

This reproduces [Figure 5](#).

Radiation Pattern 1

- 1 In the **Model Builder** window, expand the **Results > 3D Far Field, Gain (emw)** node, then click **Radiation Pattern 1**.
- 2 In the **Settings** window for **Radiation Pattern**, locate the **Evaluation** section.
- 3 Find the **Angles** subsection. In the **Number of elevation angles** text field, type 90.
- 4 In the **Number of azimuth angles** text field, type 90.
- 5 In the **3D Far Field, Gain (emw)** toolbar, click  **Plot**.
- 6 Click the  **Go to XY View** button in the **Graphics** toolbar.

The reproduced plots are shown in [Figure 6](#).

Grid 3D 1

- 1 In the **Results** toolbar, click  **More Datasets** and choose **Grid > Grid 3D**.
- 2 In the **Settings** window for **Grid 3D**, locate the **Parameter Bounds** section.
- 3 Find the **First parameter** subsection. In the **Minimum** text field, type -10.
- 4 In the **Maximum** text field, type -10.
- 5 Find the **Second parameter** subsection. In the **Minimum** text field, type -150.
- 6 In the **Maximum** text field, type 150.
- 7 Find the **Third parameter** subsection. In the **Minimum** text field, type -150.
- 8 In the **Maximum** text field, type 150.

Using **Grid 3D**, you can evaluate the far-field outside the simulation domain.

3D Plot Group 8

- 1 In the **Results** toolbar, click  **3D Plot Group**.
- 2 In the **Settings** window for **3D Plot Group**, locate the **Data** section.
- 3 From the **Parameter value (freq (GHz))** list, choose **2.13**.
- 4 Locate the **Plot Settings** section. Clear the **Plot dataset edges** checkbox.

Surface 1

- 1 Right-click **3D Plot Group 8** and choose **Surface**.
- 2 In the **Settings** window for **Surface**, locate the **Data** section.
- 3 From the **Dataset** list, choose **Grid 3D 1**.
- 4 Locate the **Expression** section. In the **Expression** text field, type `emw.gaindBefar`.

- 5 Locate the **Coloring and Style** section. From the **Color table** list, choose **Ranitomeya**.

Transparency 1

Right-click **Surface 1** and choose **Transparency**.

Volume 1

- 1 In the **Model Builder** window, right-click **3D Plot Group 8** and choose **Volume**.
- 2 In the **Settings** window for **Volume**, locate the **Coloring and Style** section.
- 3 From the **Color table** list, choose **Avicularia**.

Selection 1

- 1 Right-click **Volume 1** and choose **Selection**.
- 2 Select Domain 6 only.
- 3 In the **3D Plot Group 8** toolbar, click  **Plot**.

Volume 2

In the **Model Builder** window, right-click **3D Plot Group 8** and choose **Volume**.

Selection 1

- 1 In the **Model Builder** window, right-click **Volume 2** and choose **Selection**.
- 2 Select Domain 10 only.

Material Appearance 1

- 1 In the **Model Builder** window, right-click **Volume 2** and choose **Material Appearance**.
- 2 In the **Settings** window for **Material Appearance**, locate the **Appearance** section.
- 3 From the **Appearance** list, choose **Custom**.
- 4 From the **Material type** list, choose **Chrome**.

Deformation 1

- 1 In the **Model Builder** window, right-click **Surface 1** and choose **Deformation**.
- 2 In the **Settings** window for **Deformation**, locate the **Expression** section.
- 3 In the **x-component** text field, type 0.
- 4 In the **y-component** text field, type 55.
- 5 In the **z-component** text field, type 0.
- 6 Locate the **Scale** section.
- 7 Select the **Scale factor** checkbox. In the associated text field, type 1.
- 8 In the **3D Plot Group 8** toolbar, click  **Plot**.

9 Click the  **Zoom Out** button in the **Graphics** toolbar.

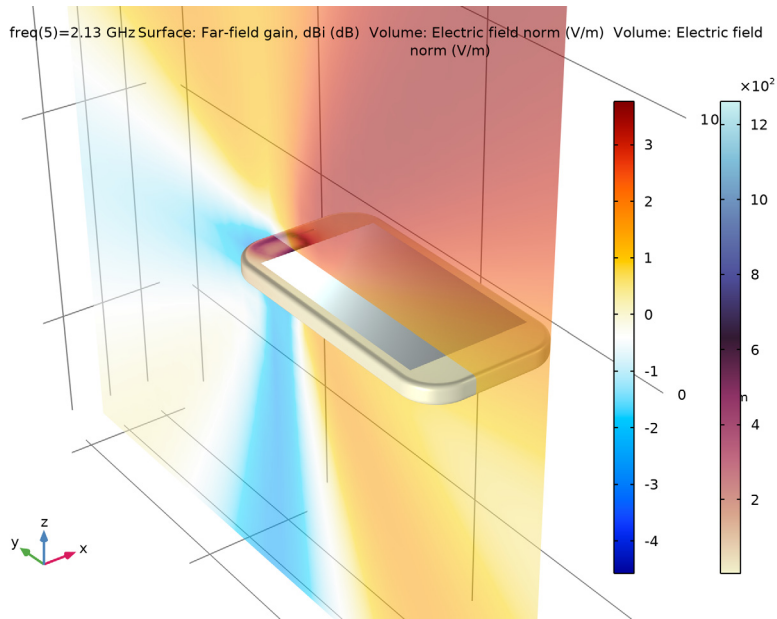

Analyze the same model with a much finer frequency resolution using **Adaptive Frequency Sweep** based on asymptotic waveform evaluation (AWE). When a device presents a slowly varying frequency response, the AWE provides a faster solution time when running the simulation on many frequency points. The following example with the AWE can be computed about twenty times faster than regular Frequency Domain sweeps with a same finer frequency resolution.

ELECTROMAGNETIC WAVES, FREQUENCY DOMAIN (EMW)

Lumped Port 1

- 1 In the **Model Builder** window, under **Component 1 (comp1) > Electromagnetic Waves, Frequency Domain (emw)** click **Lumped Port 1**.
- 2 In the **Settings** window for **Lumped Port**, locate the **Boundary Selection** section.
- 3 Click  **Create Selection**.
- 4 In the **Create Selection** dialog, type Lumped port 1 in the **Selection name** text field.
- 5 Click **OK**.

ADD STUDY

- 1 In the **Home** toolbar, click  **Add Study** to open the **Add Study** window.

- 2 Go to the **Add Study** window.
- 3 Find the **Studies** subsection. In the **Select Study** tree, select **Preset Studies for Selected Physics Interfaces > Adaptive Frequency Sweep**.
- 4 Click the **Add Study** button in the window toolbar.
- 5 In the **Home** toolbar, click  **Add Study** to close the **Add Study** window.

STUDY 2

- 1 In the **Settings** window for **Study**, locate the **Study Settings** section.
- 2 Clear the **Generate default plots** checkbox.

Step 1: Adaptive Frequency Sweep

- 1 In the **Model Builder** window, under **Study 2** click **Step 1: Adaptive Frequency Sweep**.
- 2 In the **Settings** window for **Adaptive Frequency Sweep**, locate the **Study Settings** section.
- 3 In the **Frequencies** text field, type range (2.11 [GHz] , 0.5 [MHz] , 2.155 [GHz]).

A slowly varying scalar value curve works well for AWE expressions. When **AWE expression type** is set to **Physics controlled** in the **Adaptive Frequency Sweep** study settings, $\text{sqrt}(1 - \text{abs}(\text{comp1.emw.S11})^2)$ is used automatically for one-port devices.

Because such a fine frequency step generates a memory-intensive solution, the model file size will increase tremendously when it is saved. When only the frequency response of port related variables are of interest, it is not necessary to store all of the field solutions. By selecting the **Store in Output** checkbox in the **Values of Dependent Variables** section, we can control the part of the model on which the computed solution is saved. We only add the selection containing these boundaries where the port variables are calculated. The lumped port size is typically very small compared to the entire modeling domain, and the saved file size with the fine frequency step is more or less that of the regular discrete frequency sweep model when only the solutions on the lumped port boundaries are stored.

- 4 Click to expand the **Store in Output** section. In the table, enter the following settings:

Interface	Output
Electromagnetic Waves, Frequency Domain (emw)	Selection

- 5 Click to select the first row in the table.
- 6 Under **Selections**, click  **Add**.
- 7 In the **Add** dialog, select **Lumped port 1** in the **Selections** list.

8 Click **OK**.

It is necessary to include the lumped port boundaries to calculate S-parameters. By choosing only the lumped port boundaries for **Store in Output** settings, it is possible to reduce the size of a model file a lot.

9 In the **Study** toolbar, click  **Compute**.

RESULTS

ID Plot Group 9

In the **Results** toolbar, click  **ID Plot Group**.

Global 1

- 1 Right-click **ID Plot Group 9** and choose **Global**.
- 2 In the **Settings** window for **Global**, locate the **y-Axis Data** section.
- 3 In the table, enter the following settings:

Expression	Unit	Description
emw.S11dB	dB	S11 Regular Sweep

- 4 Click to expand the **Coloring and Style** section. Find the **Line markers** subsection. From the **Marker** list, choose **Cycle**.

Global 2

- 1 In the **Model Builder** window, right-click **ID Plot Group 9** and choose **Global**.
- 2 In the **Settings** window for **Global**, locate the **Data** section.
- 3 From the **Dataset** list, choose **Probe Solution 2 (sol2)**.
- 4 Locate the **y-Axis Data** section. In the table, enter the following settings:

Expression	Unit	Description
emw.S11dB	dB	S11 Adaptive Frequency Sweep

5 In the **ID Plot Group 9** toolbar, click  **Plot**.

