

Model created in COMSOL Multiphysics 6.4

RF Implant Heating in MRI

Introduction

Magnetic resonance imaging (MRI) relies on the application of time-varying magnetic fields. Among those, radio frequency (RF) fields are used for volumetric excitation of the target. This tutorial model focuses on the RF excitation and its heating effect on a passive conductive implant inserted into anatomical vertebrae¹ and plunged into a jelly phantom having human body's tissue properties.

RF-induced heating occurs any time a material with finite mass is invested by RF power; this is usually referred to as *specific absorption rate* (SAR):

$$\text{SAR} = \sigma \frac{|\mathbf{E}|^2}{\rho} \quad (1)$$

where σ is the conductivity of material, ρ is the mass density, and $|\mathbf{E}|$ is the norm of the electric field (RMS). This means that a human body's tissue yields a finite SAR even without a conductive prosthesis. However, when a passive conductive implant is present in the tissue, a secondary RF field is induced in the implant that in turn generates an additional, dominant (compared to the original excitation), scattered field toward the surroundings. As a result, the RF power absorption by the tissue, and thus the SAR, are locally enhanced. The resulting local heating increase and consequent tissue damage represent one of the major hazards for the patient under MRI test.

This *MRI implant heating* tutorial model shows the RF-induced heating on a passive conductive polyaxial screw implant inserted into C3-C4-C5 anatomical vertebrae and plunged into a jelly phantom brick so as to mimic the tissue enclosing the spine. The phantom has standard physical properties and geometry as reported in the ASTM-F2182-19e2 standard. The SAR is computed in a first Frequency Domain study step. The resulting heating is coupled to a second Time Dependent study step to assess temperature increase consistently with the procedure reported in the ASTM-F2182-19e2 standard.

Model Definition

The geometry of the system is shown in [Figure 1](#). The 3D model consists of a birdcage coil for RF excitation, a phantom brick having human body's tissue properties, a series of C3-C4-C5 vertebrae, and a polyaxial screw implant. The vertebrae and polyaxial screws are taken directly from the tutorial *STL Import 2 — Combining Geometry with an*

1. The STL geometry is provided courtesy of Mark Yeoman, Continuum Blue, UK.

Imported Mesh in the COMSOL Multiphysics Application Library; they are shown enlarged in [Figure 2](#) for better visualization.

The RF excitation is the same used in *MRI coil* tutorial model; shortly: two lumped ports are used for quadrature excitation and a number of lumped-element capacitors are included for fine frequency tuning and field uniformity inside the MRI chamber.

The 3D mesh is shown in [Figure 3](#). It is built using a free tetrahedral mesh for all domains except for a swept mesh with a distributed number of elements in the outer PML domain.

The implementation requires the use of the Electromagnetic Waves, Frequency Domain interface and the Heat Transfer in Solids interface. The former interface is used to compute the SAR in the phantom and vertebrae at 63.87 MHz operation frequency. The resulting heating is then incorporated into the latter interface via a multiphysics coupling in order to evaluate the temperature evolution over 6 minutes of steady RF-heating exposure.

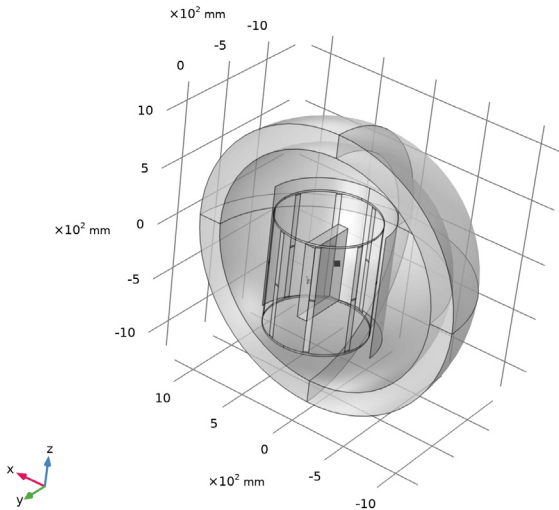

Figure 1: 3D geometry of the MRI system including a birdcage coil, a phantom brick, three anatomical vertebrae and a polyaxial screw implant.

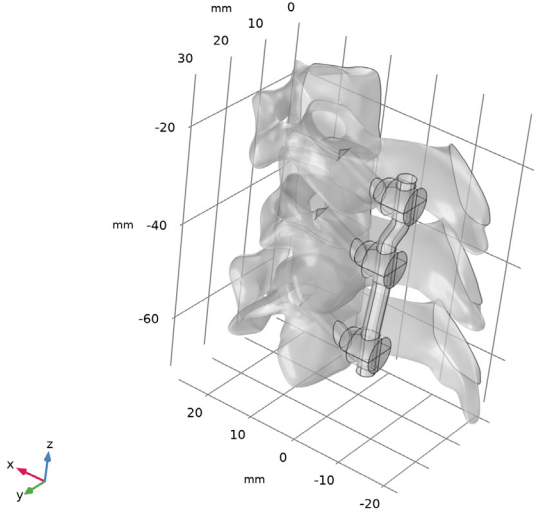

Figure 2: Zoomed view on the polyaxial screw implant inserted into C3-C4-C5 vertebrae.

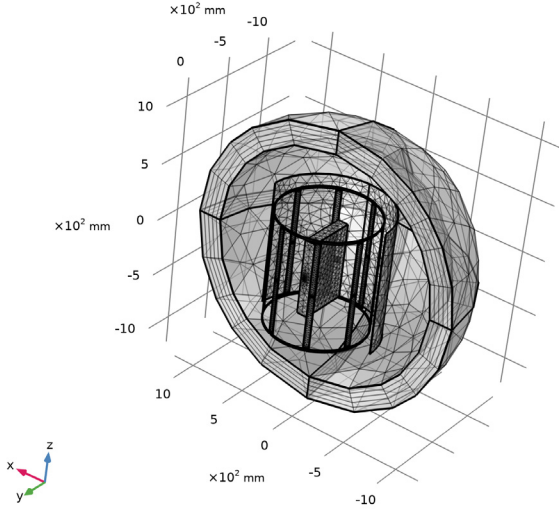

Figure 3: Computational mesh used in this tutorial.

Results and Discussion

Two study steps are performed in this tutorial: a Frequency Domain study step to evaluate the SAR and a Time Dependent study step to assess the temperature rise consequent to the RF heating.

Figure 4 displays, on the primary y-axis, the temperature rise over time (with respect to the baseline) at two point probes located at the distal ends of the implant's rod. The secondary y-axis reports the background SAR at a reference point probe in the phantom specular to the implant location.

Figure 5 shows the electric field norm on the implant surface remarking that the field strengthens at the distal ends of the implant. This field enhancement stems from the scattering induced by the implant.

Figure 6 depicts the SAR on a phantom region surrounding the vertebrae and the implant. The SAR is maximum at the same locations where the RF field strengthens (see Figure 5).

Figure 7 shows the temperature distribution on the implant after 6 minutes of steady RF-heating exposure. This result is consistent with the plot of Figure 4.

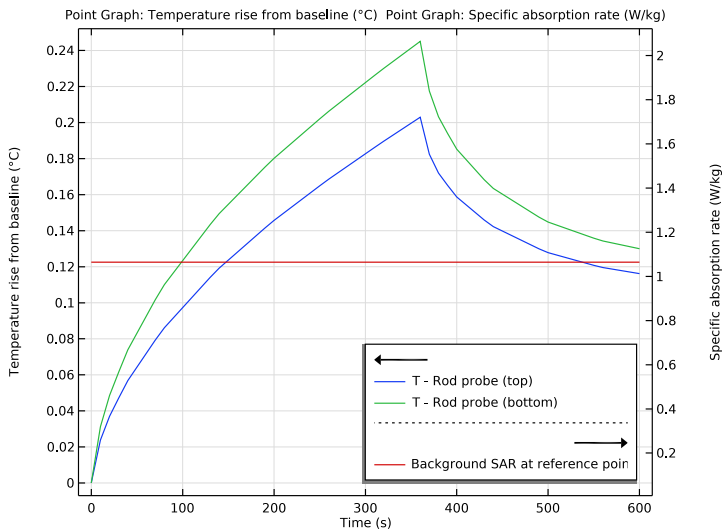

Figure 4: (left axis) Temperature evolution at rod probes, (right axis) SAR at reference probe.

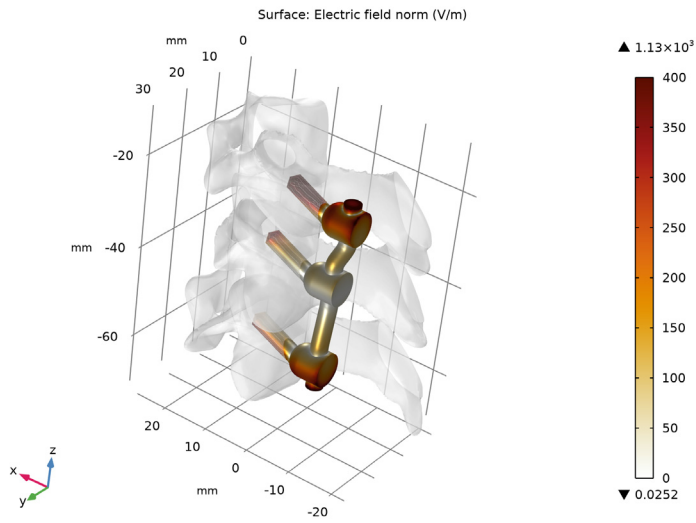

Figure 5: Electric field norm on the implant surface.

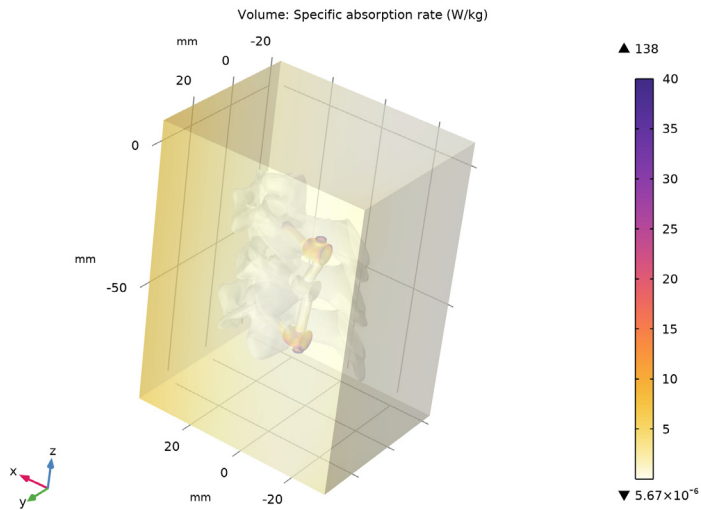

Figure 6: SAR on a phantom region surrounding the implant and the vertebrae.

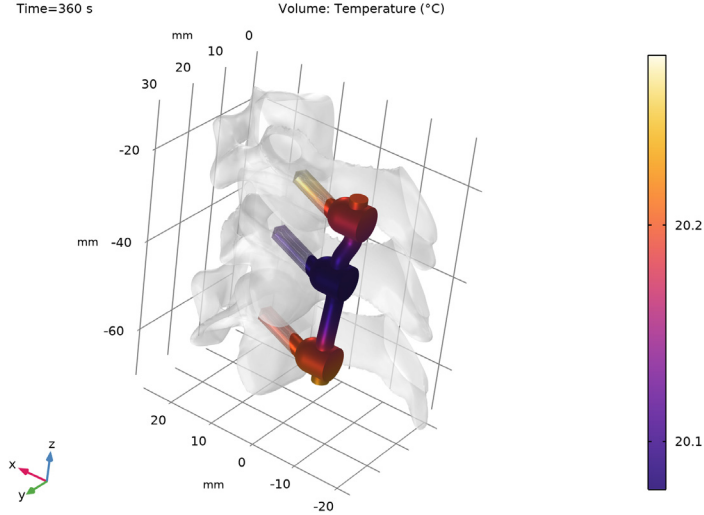

Figure 7: Temperature distribution on the implant after 6 min of RF-heating exposure.

Reference

1. Reprinted, with permission from ASTM-F2182-19e2, Standard Test Method for Measurement of Radio Frequency Induced Heating On or Near Passive Implants During Magnetic Resonance Imaging, copyright ASTM International. A copy of the complete standard may be obtained from ASTM, www.astm.org.

Application Library path: RF_Module/Microwave_Heating/mri_implant_heating

Modeling Instructions

From the **File** menu, choose **New**.

NEW

In the **New** window, click  **Model Wizard**.

MODEL WIZARD

I In the **Model Wizard** window, click  **3D**.

2 Click  **Done**.

ROOT

- 1 From the **File** menu, choose **Open**.
- 2 Browse to the model's Application Libraries folder and double-click the file `stl_2_combine_geom_mesh_geom_sequence.mph`.

GLOBAL DEFINITIONS

Parameters - Vertebrae and Screw

- 1 In the **Model Builder** window, under **Global Definitions** click **Parameters I**.
- 2 In the **Settings** window for **Parameters**, type Parameters - Vertebrae and Screw in the **Label** text field.

Parameters - Birdcage Coil

- 1 In the **Home** toolbar, click  **Parameters** and choose **Add > Parameters**.
- 2 In the **Settings** window for **Parameters**, type Parameters - Birdcage Coil in the **Label** text field.
- 3 Locate the **Parameters** section. In the table, enter the following settings:

Name	Expression	Value	Description
c_value	29.5[pF]	2.95E-11 F	Capacitance used on the rungs
r_coil	xPhantom		Radius of the coil
h_coil	1.5*zPhantom		Height of the coil
l_element	0.01[m]	0.01 m	Length of the capacitive elements
t_ring	0.015[m]	0.015 m	Thickness of the ring
f0	63.87[MHz]	6.387E7 Hz	Operating frequency
wl0	c_const/f0	4.6938 m	Free space wavelength
rAir	1.2[m]	1.2 m	Radius of air sphere
tPml	0.2[m]	0.2 m	PML thickness
V0	540[V]	540 V	Voltage excitation

Parameters - Phantom

- 1 In the **Home** toolbar, click  **Parameters** and choose **Add > Parameters**.
- 2 In the **Settings** window for **Parameters**, type Parameters - Phantom in the **Label** text field.

3 Locate the **Parameters** section. In the table, enter the following settings:

Name	Expression	Value	Description
xPhantom	42[cm]	0.42 m	Phantom length along x-axis
yPhantom	9[cm]	0.09 m	Phantom length along y-axis
zPhantom	65[cm]	0.65 m	Phantom length along z-axis
epsrPhantom	80	80	Relative permittivity phantom
sigmaPhantom	0.47[S/m]	0.47 S/m	Electrical conductivity phantom
murPhantom	1	1	Relative permeability phantom
cPhantom	4150[J/kg/K]	4150 J/(kg·K)	Heat capacity phantom
alphaPhantom	1.3e-7[m^2/s]	1.3E-7 m ² /s	Thermal diffusivity phantom
volPhantom	xPhantom*yPhantom*zPhantom	0.02457 m ³	Volume of phantom
rhoNaCl	1.32[g/L]	1.32 kg/m ³	Density of NaCl
rhoPAA	10[g/L]	10 kg/m ³	Density of polyacrylic acid (PAA)
rhoPhantom	rhoWater+ rhoNaCl + rhoPAA	1004.6 kg/m ³	Density of phantom
rhoWater	993.31[kg/m^3]	993.31 kg/m ³	Density of water at 37C
kPhantom	alphaPhantom* rhoPhantom* cPhantom	0.542 W/(m·K)	Thermal conductivity of phantom
dWall	2[cm]	0.02 m	Distance from phantom wall

First, build the geometry of the polyaxial screw and rod.

GEOMETRY I

Delete Entities I (delI)

- 1 In the **Model Builder** window, expand the **Component I (comp1) > Geometry I** node, then click **Delete Entities I (delI)**.
- 2 In the **Settings** window for **Delete Entities**, click  **Build Selected**.

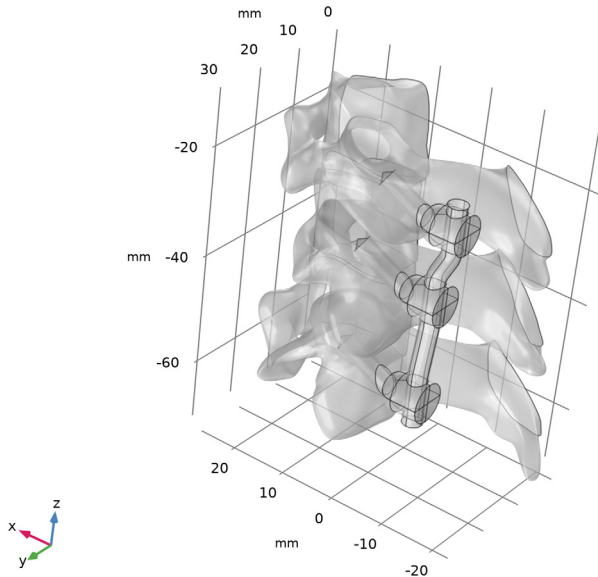



Second, import the geometry sequence for the birdcage coil and phantom, then build all.

- 3 In the **Geometry** toolbar, click **Insert Sequence** and choose **Insert Sequence**.
- 4 Browse to the model's Application Libraries folder and double-click the file `mri_implant_heating_geom_sequence.mph`.
- 5 In the **Geometry** toolbar, click  **Build All**.



Now define useful selections under the Geometry node.

Non-PML

- 1 In the **Geometry** toolbar, click  **Selections** and choose **Ball Selection**.
- 2 In the **Settings** window for **Ball Selection**, type Non-PML in the **Label** text field.
- 3 Locate the **Ball Center** section. In the **x** text field, type `-0.705[cm]`.
- 4 In the **y** text field, type `-xPhantom/2+dWall+d_rod/2+1.15*c3_zw`.

- 5 In the **z** text field, type $-(c3_xw+c5_xw)/2$.
- 6 Locate the **Ball Radius** section. In the **Radius** text field, type $rAir-tPm1/2$.
- 7 Locate the **Output Entities** section. From the **Include entity if** list, choose **Entity inside ball**.
- 8 Click  **Build Selected**.

PML

- 1 In the **Geometry** toolbar, click  **Selections** and choose **Complement Selection**.
- 2 In the **Settings** window for **Complement Selection**, type PML in the **Label** text field.
- 3 Locate the **Input Entities** section. Click  **Add**.
- 4 In the **Add** dialog, select **Non-PML** in the **Selections to invert** list.
- 5 Click **OK**.
- 6 In the **Settings** window for **Complement Selection**, click  **Build Selected**.

Non-PML Boundaries

- 1 In the **Model Builder** window, under **Component 1 (comp1) > Geometry 1** right-click **Non-PML (ballsel1)** and choose **Duplicate**.
- 2 In the **Settings** window for **Ball Selection**, type Non-PML Boundaries in the **Label** text field.
- 3 Locate the **Geometric Entity Level** section. From the **Level** list, choose **Boundary**.

Build the mesh-based geometry and perform a mesh cleanup.

MESH-BASED GEOMETRY 1

Union 1

- 1 In the **Model Builder** window, expand the **Component 1 (comp1) > Mesh-Based Geometry 1** node, then click **Union 1**.
- 2 In the **Settings** window for **Union**, locate the **Cleanup** section.
- 3 From the **Repair tolerance** list, choose **Absolute**.
- 4 In the **Absolute tolerance** text field, type 0.01 [mm].
- 5 In the **Model Builder** window, right-click **Mesh-Based Geometry 1** and choose **Build All**.
- 6 Right-click **Mesh-Based Geometry 1** and choose **Cleanup and Repair > Cleanup Wizard**.

CLEANUP WIZARD

- 1 Go to the **Cleanup Wizard** window.
- 2 Click the **Manual** button.

- 3 In the **Detail size** text field, type 0.1 [mm].
- 4 Click the **Apply** button in the window toolbar.
- 5 Click the **Apply** button in the window toolbar.
- 6 Click the **Done** button in the window toolbar.



DEFINITIONS (COMPI)

Step 1 (step 1)



- 1 In the **Definitions** toolbar, click  **More Functions** and choose **Step**.
- 2 In the **Settings** window for **Step**, locate the **Parameters** section.
- 3 In the **Location** text field, type 0.25.

Continue setting selections under the Definitions node.



Vertebrae and Screws

- 1 In the **Definitions** toolbar, click  **Union**.
- 2 In the **Settings** window for **Union**, type Vertebrae and Screws in the **Label** text field.
- 3 Locate the **Input Entities** section. Under **Selections to add**, click  **Add**.
- 4 In the **Add** dialog, in the **Selections to add** list, choose **Vertebrae** and **Screw Domains**.
- 5 Click **OK**.

Discs



- 1 In the **Definitions** toolbar, click  **Union**.
- 2 In the **Settings** window for **Union**, type Discs in the **Label** text field.
- 3 Locate the **Input Entities** section. Under **Selections to add**, click  **Add**.
- 4 In the **Add** dialog, select **Discs** in the **Selections to add** list.
- 5 Click **OK**.

Vertebrae



- 1 In the **Definitions** toolbar, click  **Difference**.
- 2 In the **Settings** window for **Difference**, type Vertebrae in the **Label** text field.
- 3 Locate the **Input Entities** section. Under **Selections to add**, click  **Add**.
- 4 In the **Add** dialog, select **Vertebrae and Screws** in the **Selections to add** list.
- 5 Click **OK**.
- 6 In the **Settings** window for **Difference**, locate the **Input Entities** section.
- 7 Under **Selections to subtract**, click  **Add**.

- 8 In the **Add** dialog, select **Screw Domains** in the **Selections to subtract** list.
- 9 Click **OK**.

Port 1

- 1 In the **Definitions** toolbar, click  **Explicit**.
- 2 In the **Settings** window for **Explicit**, type Port 1 in the **Label** text field.
- 3 Locate the **Input Entities** section. From the **Geometric entity level** list, choose **Boundary**.
- 4 Click  **Paste Selection**.
- 5 In the **Paste Selection** dialog, type 36 in the **Selection** text field.
- 6 Click **OK**.



Port 2

- 1 In the **Definitions** toolbar, click  **Explicit**.
- 2 In the **Settings** window for **Explicit**, type Port 2 in the **Label** text field.
- 3 Locate the **Input Entities** section. From the **Geometric entity level** list, choose **Boundary**.
- 4 Click  **Paste Selection**.
- 5 In the **Paste Selection** dialog, type 21 in the **Selection** text field.
- 6 Click **OK**.



Phantom

- 1 In the **Definitions** toolbar, click  **Explicit**.
- 2 In the **Settings** window for **Explicit**, type Phantom in the **Label** text field.
- 3 Select Domain 6 only.

HT Domain

- 1 In the **Definitions** toolbar, click  **Union**.
- 2 In the **Settings** window for **Union**, type HT Domain in the **Label** text field.
- 3 Locate the **Input Entities** section. Under **Selections to add**, click  **Add**.
- 4 In the **Add** dialog, in the **Selections to add** list, choose **Vertebrae and Screws**, **Discs**, **Phantom**, and **Rod domain**.
- 5 Click **OK**.

Implant

- 1 In the **Definitions** toolbar, click  **Union**.
- 2 In the **Settings** window for **Union**, type Implant in the **Label** text field.
- 3 Locate the **Input Entities** section. Under **Selections to add**, click  **Add**.

- 4 In the **Add** dialog, in the **Selections to add** list, choose **Screw Domains** and **Rod domain**.
- 5 Click **OK**.



Implant Boundary

- 1 In the **Definitions** toolbar, click  **Adjacent**.
- 2 In the **Settings** window for **Adjacent**, type **Implant Boundary** in the **Label** text field.
- 3 Locate the **Input Entities** section. Under **Input selections**, click **+ Add**.
- 4 In the **Add** dialog, select **Implant** in the **Input selections** list.
- 5 Click **OK**.

SAR Domain

- 1 In the **Definitions** toolbar, click  **Difference**.
- 2 In the **Settings** window for **Difference**, type **SAR Domain** in the **Label** text field.
- 3 Locate the **Input Entities** section. Under **Selections to add**, click **+ Add**.
- 4 In the **Add** dialog, select **HT Domain** in the **Selections to add** list.
- 5 Click **OK**.
- 6 In the **Settings** window for **Difference**, locate the **Input Entities** section.
- 7 Under **Selections to subtract**, click **+ Add**.
- 8 In the **Add** dialog, select **Implant** in the **Selections to subtract** list.
- 9 Click **OK**.

All Elements

- 1 In the **Definitions** toolbar, click  **Explicit**.
- 2 In the **Settings** window for **Explicit**, type **All Elements** in the **Label** text field.
- 3 Locate the **Input Entities** section. From the **Geometric entity level** list, choose **Boundary**.
- 4 Click  **Paste Selection**.
- 5 In the **Paste Selection** dialog, type 19, 21, 23, 24, 26, 28, 29, 31, 33, 34, 36, 38, 171, 173, 175, 176, 178, 180, 181, 183, 185, 186, 188, 190 in the **Selection** text field.
- 6 Click **OK**.

Temperature Probes

- 1 In the **Definitions** toolbar, click  **Explicit**.
- 2 In the **Settings** window for **Explicit**, type **Temperature Probes** in the **Label** text field.
- 3 Locate the **Input Entities** section. From the **Geometric entity level** list, choose **Point**.



4 Select Points 71 and 84 only.

SAR Probe

- 1 In the **Definitions** toolbar, click  **Explicit**.
- 2 In the **Settings** window for **Explicit**, type SAR Probe in the **Label** text field.
- 3 Locate the **Input Entities** section. From the **Geometric entity level** list, choose **Point**.
- 4 Select Point 102 only.

Now add the following physics interfaces with the corresponding settings.

ADD PHYSICS



- 1 In the **Home** toolbar, click  **Add Physics** to open the **Add Physics** window.
- 2 Go to the **Add Physics** window.
- 3 In the tree, select **Radio Frequency > Electromagnetic Waves, Frequency Domain (emw)**.
- 4 Click the **Add to Component 1** button in the window toolbar.
- 5 In the tree, select **Heat Transfer > Heat Transfer in Solids (ht)**.
- 6 Click the **Add to Component 1** button in the window toolbar.
- 7 In the text field, type event.
- 8 In the tree, select **Mathematics > ODE and DAE Interfaces > Events (ev)**.
- 9 Click the **Add to Component 1** button in the window toolbar.
- 10 In the **Home** toolbar, click  **Add Physics** to close the **Add Physics** window.

ELECTROMAGNETIC WAVES, FREQUENCY DOMAIN (EMW)

Perfect Electric Conductor 2

- 1 In the **Physics** toolbar, click  **Boundaries** and choose **Perfect Electric Conductor**.
- 2 In the **Settings** window for **Perfect Electric Conductor**, locate the **Boundary Selection** section.
- 3 From the **Selection** list, choose **Coil**.

Perfect Electric Conductor 3

- 1 In the **Physics** toolbar, click  **Boundaries** and choose **Perfect Electric Conductor**.
- 2 In the **Settings** window for **Perfect Electric Conductor**, locate the **Boundary Selection** section.
- 3 Click  **Paste Selection**.
- 4 In the **Paste Selection** dialog, type 13, 14, 103, 116 in the **Selection** text field.

5 Click **OK**.

Lumped Port 1

- 1 In the **Physics** toolbar, click  **Boundaries** and choose **Lumped Port**.
- 2 In the **Settings** window for **Lumped Port**, locate the **Boundary Selection** section.
- 3 From the **Selection** list, choose **Port 1**.
- 4 Locate the **Settings** section. In the V_0 text field, type V_0 .

Lumped Port 2

- 1 In the **Physics** toolbar, click  **Boundaries** and choose **Lumped Port**.
- 2 In the **Settings** window for **Lumped Port**, locate the **Boundary Selection** section.
- 3 From the **Selection** list, choose **Port 2**.
- 4 Locate the **Lumped Port Properties** section. From the **Wave excitation at this port** list, choose **On**.
- 5 Locate the **Settings** section. In the V_0 text field, type V_0 .
- 6 In the θ_{in} text field, type $\pi/2$.

Lumped Element 1

- 1 In the **Physics** toolbar, click  **Boundaries** and choose **Lumped Element**.
- 2 Select Boundaries 19, 23, 24, 26, 28, 29, 31, 33, 34, 38, 171, 173, 175, 176, 178, 180, 181, 183, 185, 186, 188, and 190 only.
- 3 In the **Settings** window for **Lumped Element**, locate the **Settings** section.
- 4 From the **Lumped element device** list, choose **Capacitor**.
- 5 In the $C_{element}$ text field, type c_value .
- 6 Click the **Split by Connectivity** button in the window toolbar.

Specific Absorption Rate 1

- 1 In the **Physics** toolbar, click  **Domains** and choose **Specific Absorption Rate**.
- 2 In the **Settings** window for **Specific Absorption Rate**, locate the **Domain Selection** section.
- 3 From the **Selection** list, choose **SAR Domain**.

Impedance Boundary Condition 1

- 1 In the **Physics** toolbar, click  **Domains** and choose **Impedance Boundary Condition**.
- 2 In the **Settings** window for **Impedance Boundary Condition**, locate the **Domain Selection** section.
- 3 From the **Selection** list, choose **Implant**.

DEFINITIONS (COMP1)

Perfectly Matched Layer 1 (pml1)

- 1 In the **Definitions** toolbar, click  **Perfectly Matched Layer**.
- 2 In the **Settings** window for **Perfectly Matched Layer**, locate the **Domain Selection** section.
- 3 From the **Selection** list, choose **PML**.
- 4 Locate the **Geometry** section. From the **Type** list, choose **Spherical**.

HEAT TRANSFER IN SOLIDS (HT)

- 1 In the **Model Builder** window, under **Component 1 (comp1)** click **Heat Transfer in Solids (ht)**.
- 2 In the **Settings** window for **Heat Transfer in Solids**, locate the **Domain Selection** section.
- 3 From the **Selection** list, choose **HT Domain**.

Heat Flux 1

- 1 In the **Physics** toolbar, click  **Boundaries** and choose **Heat Flux**.
- 2 In the **Settings** window for **Heat Flux**, locate the **Heat Flux** section.
- 3 From the **Flux type** list, choose **Convective heat flux**.
- 4 In the h text field, type 5.
- 5 Locate the **Boundary Selection** section. From the **Selection** list, choose **All boundaries**.

Heat Source 1

- 1 In the **Physics** toolbar, click  **Domains** and choose **Heat Source**.
- 2 In the **Settings** window for **Heat Source**, locate the **Domain Selection** section.
- 3 From the **Selection** list, choose **SAR Domain**.
- 4 Locate the **Heat Source** section. In the Q_0 text field, type $\text{emw.Qrh}*\text{switch}*\text{step1}(t/1[\text{s}])$.

Boundary Heat Source 1

- 1 In the **Physics** toolbar, click  **Boundaries** and choose **Boundary Heat Source**.
- 2 In the **Settings** window for **Boundary Heat Source**, locate the **Boundary Selection** section.
- 3 From the **Selection** list, choose **Implant Boundary**.
- 4 Locate the **Boundary Heat Source** section. In the Q_b text field, type $\text{emw.Qsrh}*\text{switch}*\text{step1}(t/1[\text{s}])$.

EVENTS (EV)

In the **Model Builder** window, under **Component 1 (comp1)** click **Events (ev)**.

Discrete States I

- 1 In the **Physics** toolbar, click  **Global** and choose **Discrete States**.
- 2 In the **Settings** window for **Discrete States**, locate the **Discrete States** section.
- 3 In the table, enter the following settings:

Name	Initial value (u0)	Description
switch	1	

Explicit Event I

- 1 In the **Physics** toolbar, click  **Global** and choose **Explicit Event**.
- 2 In the **Settings** window for **Explicit Event**, locate the **Event Timings** section.
- 3 In the t_i text field, type 360[s].
- 4 Locate the **Reinitialization** section. In the table, enter the following settings:

	Expression
switch	0

At this point, add and assign the following materials to the respective domains. Set relative permeability to one for all materials.

ADD MATERIAL

- 1 In the **Materials** toolbar, click  **Add Material** to open the **Add Material** window.
- 2 Go to the **Add Material** window.
- 3 In the tree, select **Built-in > Air**.
- 4 Click the **Add to Component** button in the window toolbar.

MATERIALS

Phantom Material

- 1 In the **Model Builder** window, under **Component 1 (comp1)** right-click **Materials** and choose **Blank Material**.
- 2 In the **Settings** window for **Material**, type Phantom Material in the **Label** text field.
- 3 Select Domain 6 only.

4 Locate the **Material Contents** section. In the table, enter the following settings:

Property	Variable	Value	Unit	Property group
Relative permittivity	epsilon _{r_iso} ; epsilon _{r_ii} = epsilon _{r_iso} , epsilon _{r_ij} = 0	epsrPhantom	l	Basic
Relative permeability	mu _{r_iso} ; mu _{r_ii} = mu _{r_iso} , mu _{r_ij} = 0	murPhantom	l	Basic
Electric conductivity	sigma _{iso} ; sigma _{ii} = sigma _{iso} , sigma _{ij} = 0	sigmaPhantom	S/m	Basic
Density	rho	rhoPhantom	kg/m ³	Basic
Thermal conductivity	k _{iso} ; k _{ii} = k _{iso} , k _{ij} = 0	kPhantom	W/(m·K)	Basic
Heat capacity at constant pressure	C _p	cPhantom	J/(kg·K)	Basic

ADD MATERIAL

- 1 Go to the **Add Material** window.
- 2 In the tree, select **Material Library > Titanium Alloys > Ti - 6 Al - 4 V (Grade 5) > Ti - 6 Al - 4 V (Grade 5) [solid] > Ti - 6 Al - 4 V (Grade 5) [solid,annealed]**.
- 3 Click the **Add to Component** button in the window toolbar.

MATERIALS

Ti - 6 Al - 4 V (Grade 5) [solid,annealed] (mat3)

- 1 In the **Settings** window for **Material**, locate the **Geometric Entity Selection** section.
- 2 From the **Selection** list, choose **Implant**.

3 Locate the **Material Contents** section. In the table, enter the following settings:

Property	Variable	Value	Unit	Property group
Relative permittivity	epsilon _{nr_iso} ; epsilon _{nr_{ii}} = epsilon _{nr_iso} , epsilon _{nr_{ij}} = 0	1		Basic
Relative permeability	mu _{r_iso} ; mu _{r_{ii}} = mu _{r_iso} , mu _{r_{ij}} = 0	1		Basic

ADD MATERIAL

- 1 Go to the **Add Material** window.
- 2 In the tree, select **AC/DC > Biological Tissues > Bone Cancellous**.
- 3 Click the **Add to Component** button in the window toolbar.

MATERIALS

Bone Cancellous (mat4)

- 1 In the **Settings** window for **Material**, locate the **Geometric Entity Selection** section.
- 2 From the **Selection** list, choose **Vertebrae**.
- 3 Locate the **Material Contents** section. In the table, enter the following settings:

Property	Variable	Value	Unit	Property group
Relative permeability	mu _{r_iso} ; mu _{r_{ii}} = mu _{r_iso} , mu _{r_{ij}} = 0	1		Basic

ADD MATERIAL

- 1 Go to the **Add Material** window.
- 2 In the tree, select **Bioheat > Bone**.
- 3 Click the **Add to Component** button in the window toolbar.

MATERIALS

Bone (mat5)

In the **Model Builder** window, under **Component 1 (comp1) > Materials** right-click **Bone (mat5)** and choose **Bone Cancellous (mat4)**.

Complete missing parameters for the Cartilage material using those of the phantom and assign it to the discs between vertebrae.

ADD MATERIAL

- 1 Go to the **Add Material** window.
- 2 In the tree, select **AC/DC > Biological Tissues > Cartilage**.
- 3 Click the **Add to Component** button in the window toolbar.
- 4 In the **Materials** toolbar, click  **Add Material** to close the **Add Material** window.

MATERIALS

Cartilage (mat5)

- 1 In the **Settings** window for **Material**, locate the **Geometric Entity Selection** section.
- 2 From the **Selection** list, choose **Discs**.
- 3 Locate the **Material Contents** section. In the table, enter the following settings:

Property	Variable	Value	Unit	Property group
Relative permeability	mur_iso ; muri = mur_iso, muri_j = 0	1	l	Basic
Density	rho	rhoPhantom	kg/m ³	Basic
Thermal conductivity	k_iso ; kii = k_iso, kij = 0	kPhantom	W/(m·K)	Basic
Heat capacity at constant pressure	Cp	cPhantom	J/(kg·K)	Basic

Now build the computational mesh using the following settings.

MESH 1

Size 2

- 1 In the **Model Builder** window, expand the **Component 1 (comp1) > Mesh 1** node.

2 Right-click **Mesh 1** and choose **Size**.

Size

- 1 In the **Settings** window for **Size**, locate the **Element Size** section.
- 2 Click the **Predefined** button.
- 3 From the **Predefined** list, choose **Normal**.
- 4 Locate the **Element Size Parameters** section. In the **Maximum element size** text field, type $w_{10}/6$.
- 5 In the **Minimum element size** text field, type 18 [mm].

Size 2

- 1 In the **Model Builder** window, click **Size 2**.
- 2 In the **Settings** window for **Size**, locate the **Geometric Entity Selection** section.
- 3 From the **Geometric entity level** list, choose **Domain**.
- 4 From the **Selection** list, choose **Phantom**.
- 5 Locate the **Element Size** section. Click the **Custom** button.
- 6 Locate the **Element Size Parameters** section.
- 7 Select the **Maximum element size** checkbox. In the associated text field, type $w_{10}/10/\text{sqrt}(\text{epsrPhantom})$.
- 8 Select the **Minimum element size** checkbox. In the associated text field, type 1 [mm].

Size 3

- 1 In the **Model Builder** window, right-click **Mesh 1** and choose **Size**.
- 2 In the **Settings** window for **Size**, locate the **Geometric Entity Selection** section.
- 3 From the **Geometric entity level** list, choose **Boundary**.
- 4 From the **Selection** list, choose **Coil**.
- 5 Locate the **Element Size** section. Click the **Custom** button.
- 6 Locate the **Element Size Parameters** section.
- 7 Select the **Maximum element size** checkbox. In the associated text field, type 22 [mm].

Size 4

- 1 Right-click **Mesh 1** and choose **Size**.
- 2 In the **Settings** window for **Size**, locate the **Geometric Entity Selection** section.
- 3 From the **Geometric entity level** list, choose **Boundary**.
- 4 From the **Selection** list, choose **All Elements**.

- 5 Locate the **Element Size** section. Click the **Custom** button.
- 6 Locate the **Element Size Parameters** section.
- 7 Select the **Maximum element size** checkbox. In the associated text field, type 8[mm].

Size 5

- 1 Right-click **Mesh 1** and choose **Size**.
- 2 In the **Settings** window for **Size**, locate the **Geometric Entity Selection** section.
- 3 From the **Geometric entity level** list, choose **Boundary**.
- 4 From the **Selection** list, choose **Implant Boundary**.
- 5 Locate the **Element Size** section. Click the **Custom** button.
- 6 Locate the **Element Size Parameters** section.
- 7 Select the **Maximum element size** checkbox. In the associated text field, type d_rod/3.



Free Tetrahedral 1

- 1 In the **Mesh** toolbar, click  **Free Tetrahedral**.
- 2 In the **Settings** window for **Free Tetrahedral**, locate the **Domain Selection** section.
- 3 From the **Geometric entity level** list, choose **Domain**.
- 4 From the **Selection** list, choose **Non-PML**.

Swept 1

- 1 In the **Mesh** toolbar, click  **Swept**.
- 2 In the **Settings** window for **Swept**, locate the **Domain Selection** section.
- 3 From the **Geometric entity level** list, choose **Domain**.
- 4 From the **Selection** list, choose **PML**.

Distribution 1

- 1 Right-click **Swept 1** and choose **Distribution**.
- 2 Right-click **Mesh 1** and choose **Build All**.
- 3 In the **Graphics** window toolbar, click  next to  **Select Domains**, then choose **Select Boundaries**.
- 4 Click the  **Click and Hide** button in the **Graphics** toolbar.
- 5 Select Boundaries 4, 7, 8, 11, 12, 14, 106, 108–110, 112, 113, 116, and 117 only.

GEOMETRY 1

- 1 In the **Model Builder** window, under **Component 1 (comp1)** click **Geometry 1**.
- 2 Click the  **Click and Hide** button in the **Graphics** toolbar.

3 On the object **cmfl**, select Boundaries 4, 7, 8, 11, 12, 14, 100, 102–104, 106, 107, 110, and 111 only.

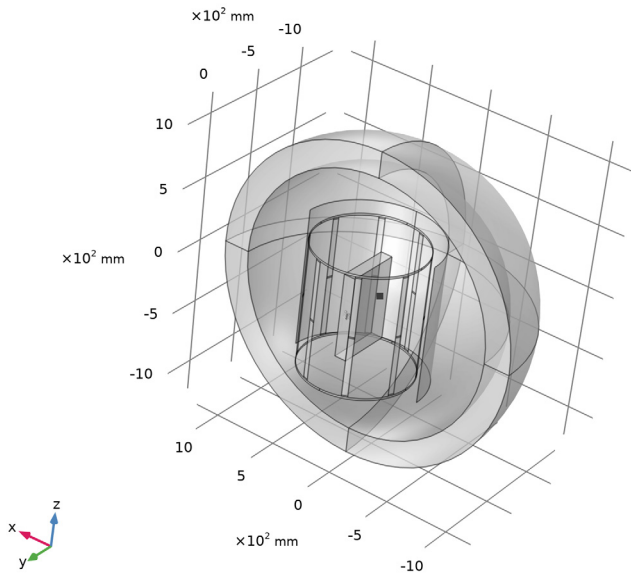

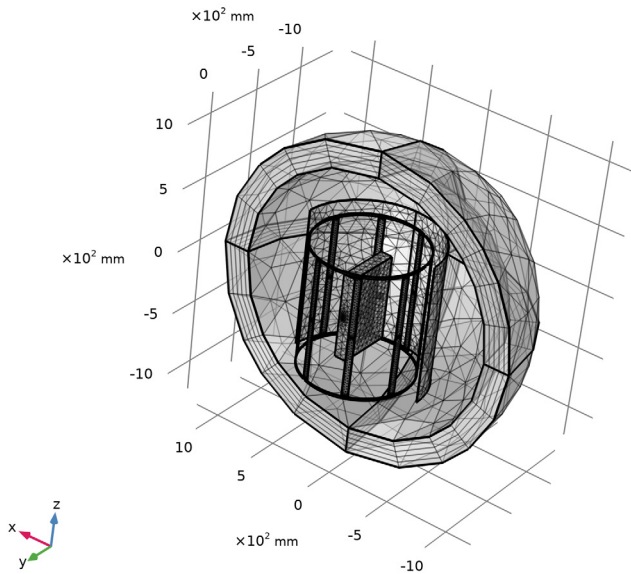

MESH 1

In the **Model Builder** window, under **Component 1 (comp1)** click **Mesh 1**.



ADD STUDY

- 1 In the **Home** toolbar, click  **Add Study** to open the **Add Study** window.
- 2 Go to the **Add Study** window.
- 3 Find the **Studies** subsection. In the **Select Study** tree, select **Preset Studies for Some Physics Interfaces > Frequency Domain**.
- 4 Click the **Add Study** button in the window toolbar.
- 5 In the **Home** toolbar, click  **Add Study** to close the **Add Study** window.

STUDY 1

Step 1: Frequency Domain

Finally, set up the two study steps and then compute.

- 1 In the **Settings** window for **Frequency Domain**, locate the **Study Settings** section.
- 2 In the **Frequencies** text field, type $f0$.

Step 2: Time Dependent

- 1 In the **Study** toolbar, click  **Time Dependent**.

- 2 In the **Settings** window for **Time Dependent**, locate the **Study Settings** section.
- 3 In the **Output times** text field, type range (0, 10, 600).
- 4 In the **Study** toolbar, click  **Compute**.

RESULTS



Study 1/Solution 1 (sol1)

In the **Model Builder** window, expand the **Results > Datasets** node, then click **Study 1/Solution 1 (sol1)**.

Selection

- 1 In the **Results** toolbar, click  **Attributes** and choose **Selection**.
- 2 In the **Settings** window for **Selection**, locate the **Geometric Entity Selection** section.
- 3 From the **Geometric entity level** list, choose **Domain**.
- 4 From the **Selection** list, choose **HT Domain**.

Temperature Evolution

- 1 In the **Results** toolbar, click  **ID Plot Group**.
- 2 In the **Settings** window for **ID Plot Group**, type Temperature Evolution in the **Label** text field.
- 3 Locate the **Plot Settings** section. Select the **Two y-axes** checkbox.
- 4 Click the  **Show Legends** button in the **Graphics** toolbar.
- 5 Locate the **Legend** section. Select the **Show legends** checkbox.
- 6 From the **Position** list, choose **Lower right**.

Point Graph 1

- 1 Right-click **Temperature Evolution** and choose **Point Graph**.
- 2 In the **Settings** window for **Point Graph**, locate the **Selection** section.
- 3 From the **Selection** list, choose **Temperature Probes**.
- 4 Locate the **y-Axis Data** section. In the **Expression** text field, type T.
- 5 From the **Unit** list, choose **°C**.
- 6 In the **Expression** text field, type T-20.
- 7 Select the **Description** checkbox. In the associated text field, type Temperature rise from baseline.
- 8 Click to expand the **Legends** section. From the **Legends** list, choose **Manual**.

9 In the table, enter the following settings:

Legends

T - Rod probe (top)

T - Rod probe (bottom)

Point Graph 2



- 1 In the **Model Builder** window, right-click **Temperature Evolution** and choose **Point Graph**.
- 2 In the **Settings** window for **Point Graph**, locate the **Selection** section.
- 3 From the **Selection** list, choose **SAR Probe**.
- 4 Locate the **y-Axis Data** section. In the **Expression** text field, type `emw.SAR`.
- 5 Locate the **y-Axis** section. Select the **Plot on secondary y-axis** checkbox.
- 6 Locate the **Legends** section. From the **Legends** list, choose **Manual**.
- 7 In the table, enter the following settings:

Legends

Background SAR at reference point

- 8 In the **Temperature Evolution** toolbar, click  **Plot**.

Temperature Evolution

- 1 Click the  **Show Legends** button in the **Graphics** toolbar.
- 2 Click the  **Zoom Extents** button in the **Graphics** toolbar.

3 In the **Model Builder** window, click **Temperature Evolution**.

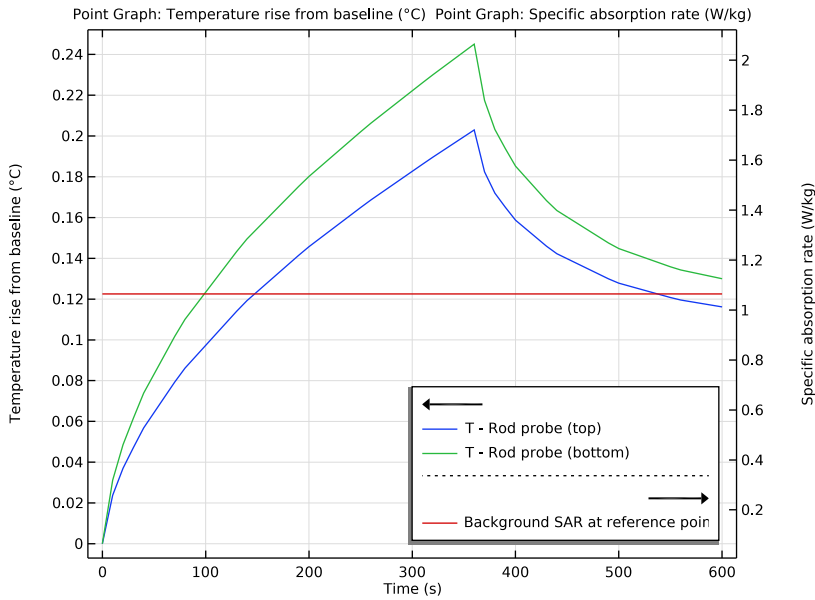

Multislice 1

- 1 In the **Model Builder** window, expand the **Electric Field (emw)** node.
- 2 Right-click **Multislice 1** and choose **Delete**.

Electric Field (emw)

- 1 In the **Settings** window for **3D Plot Group**, click to expand the **Title** section.
- 2 From the **Title type** list, choose **Manual**.
- 3 In the **Title** text area, type Surface: Electric field norm (V/m).
- 4 Clear the **Parameter indicator** text field.
- 5 Locate the **Plot Settings** section. Clear the **Plot dataset edges** checkbox.

Surface 1

- 1 Right-click **Electric Field (emw)** and choose **Surface**.
- 2 In the **Settings** window for **Surface**, locate the **Expression** section.
- 3 In the **Expression** text field, type 1.

Transparency 1

Right-click **Surface 1** and choose **Transparency**.

Material Appearance 1

- 1 In the **Model Builder** window, right-click **Surface 1** and choose **Material Appearance**.
- 2 In the **Settings** window for **Material Appearance**, locate the **Appearance** section.
- 3 From the **Material** list, choose **Bone Cancellous (mat4)**.
- 4 In the **Electric Field (emw)** toolbar, click  **Plot**.

Surface 2

- 1 In the **Model Builder** window, right-click **Electric Field (emw)** and choose **Surface**.
- 2 In the **Settings** window for **Surface**, click to expand the **Range** section.
- 3 Select the **Manual color range** checkbox.
- 4 In the **Maximum** text field, type 400.
- 5 Locate the **Coloring and Style** section. From the **Color table** list, choose **Amber**.

Material Appearance 1

- 1 Right-click **Surface 2** and choose **Material Appearance**.
- 2 In the **Settings** window for **Material Appearance**, locate the **Appearance** section.
- 3 From the **Material** list, choose **Ti - 6 Al - 4 V (Grade 5) [solid,annealed] (mat3)**.
- 4 In the **Electric Field (emw)** toolbar, click  **Plot**.
- 5 Locate the **Color** section. Select the **Use the plot's color** checkbox.

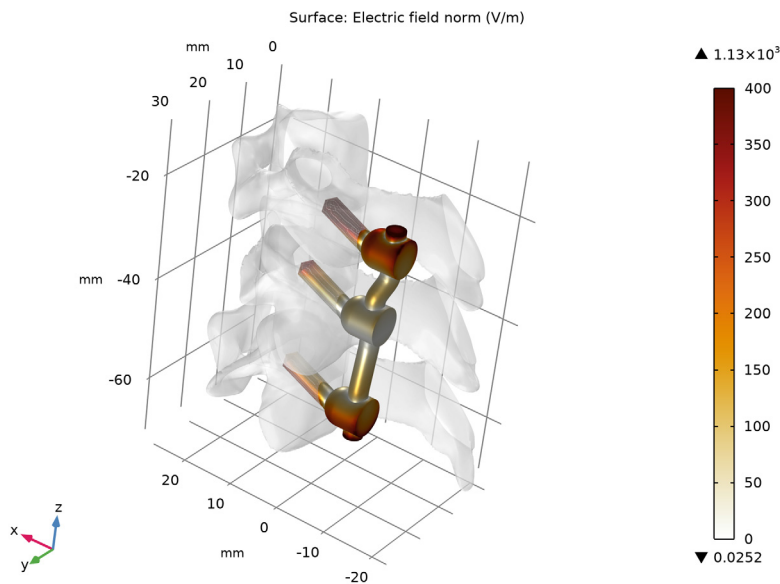

Surface 1

In the **Model Builder** window, under **Results** > **Electric Field (emw)** right-click **Surface 1** and choose **Copy**.

Specific Absorption Rate (sar1)

- 1 In the **Model Builder** window, under **Results** click **Specific Absorption Rate (sar1)**.
- 2 In the **Settings** window for **3D Plot Group**, locate the **Title** section.
- 3 From the **Title type** list, choose **Manual**.
- 4 In the **Title** text area, type Volume: Specific absorption rate (W/kg).
- 5 Clear the **Parameter indicator** text field.
- 6 Locate the **Plot Settings** section. Clear the **Plot dataset edges** checkbox.

Surface 1

Right-click **Specific Absorption Rate (sar1)** and choose **Paste Surface**.

Volume 1

- 1 In the **Settings** window for **Volume**, click to expand the **Range** section.
- 2 Select the **Manual color range** checkbox.
- 3 In the **Maximum** text field, type 40.

Transparency 1

Right-click **Volume 1** and choose **Transparency**.

Filter 1

- 1 Right-click **Volume 1** and choose **Filter**.
- 2 In the **Settings** window for **Filter**, locate the **Element Selection** section.
- 3 In the **Logical expression for inclusion** text field, type $\text{abs}(x-15[\text{mm}]) < 50[\text{mm}] \ \&\& \ y > -20[\text{mm}] \ \&\& \ z < 10[\text{mm}] \ \&\& \ z > -90[\text{mm}]$.

- 4 In the **Specific Absorption Rate (sar1)** toolbar, click  **Plot**.

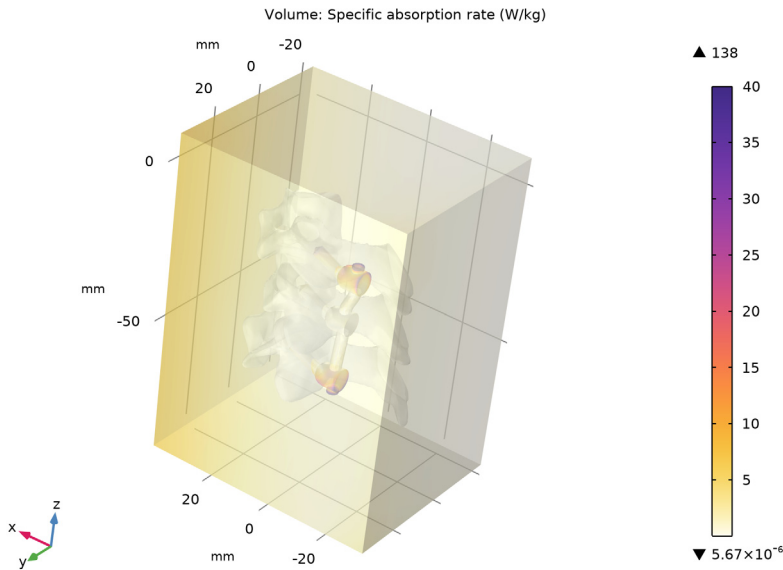

Temperature (ht)

- 1 In the **Model Builder** window, under **Results** click **Temperature (ht)**.
- 2 In the **Settings** window for **3D Plot Group**, locate the **Data** section.
- 3 From the **Time (s)** list, choose **360**.
- 4 Locate the **Title** section. From the **Title type** list, choose **Manual**.
- 5 In the **Title** text area, type Volume: Temperature (°C).
- 6 In the **Parameter indicator** text field, type Time=360 s.
- 7 Locate the **Plot Settings** section. Clear the **Plot dataset edges** checkbox.

Surface 1

Right-click **Temperature (ht)** and choose **Paste Surface**.

Volume 1

- 1 In the **Settings** window for **Volume**, locate the **Expression** section.
- 2 From the **Unit** list, choose **°C**.

Material Appearance 1

- 1 Right-click **Volume 1** and choose **Material Appearance**.

- 2 In the **Settings** window for **Material Appearance**, locate the **Appearance** section.
- 3 From the **Material** list, choose **Ti - 6 Al - 4 V (Grade 5) [solid,annealed] (mat3)**.
- 4 Locate the **Color** section. Select the **Use the plot's color** checkbox.

