



Model created in COMSOL Multiphysics 6.4

Modeling of a Phased Array Antenna

Introduction

The demand for phased array antennas increases not only for the traditional military industry but also in commercial areas such as 5G mobile network platforms, Internet of Things (IoT), and satellite communication applications. This example shows how to design a phased array with a beam scanning functionality based on the arithmetic phase difference between the array elements. The initial complicated model can be reduced to a simple single unit cell model with periodic conditions to make the analysis faster and more efficient. Two phased array designs built with microstrip patch antennas are studied and they are in good agreement with the antenna gain.

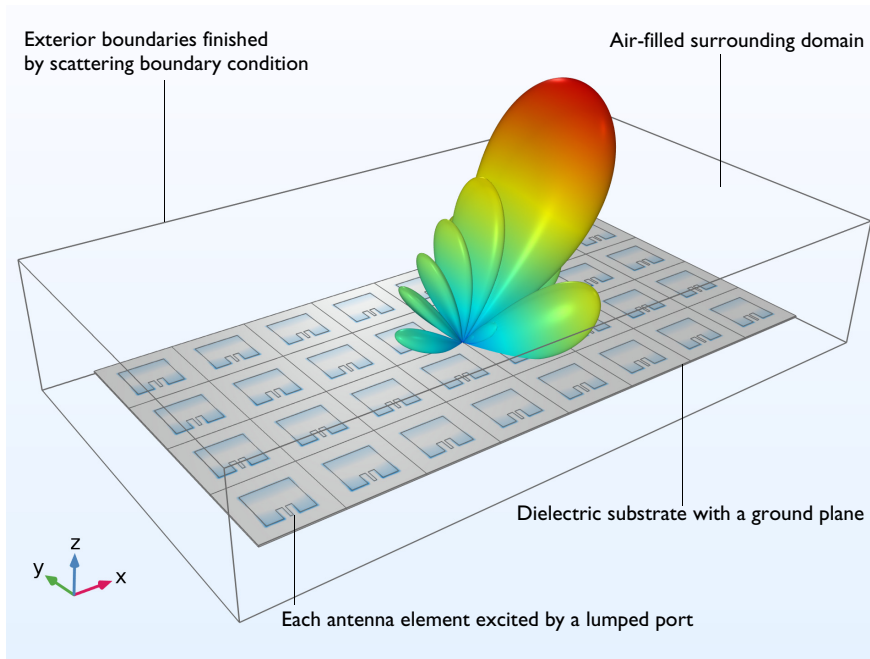

Figure 1: 8-by-4 antenna array with the far-field radiation pattern in dB scale. The main beam is 30 degrees tilted from the normal z-axis. The electric field norm on the antenna substrate is also visualized.

Model Definition

This example consists of three parts:

- Antenna geometry part showing how to make a geometry repeatedly used in the same model

- 8-by-4 full antenna array
- Simplified model using periodic conditions

ANTENNA GEOMETRY PART

When a simulation model has repeated geometry designs, it would be cumbersome to draw that geometry over and over again. If there is a predefined geometry frequently used, the modeling process can be more efficient. The RF Module includes the part library consisting of many standard parts and geometries. They are various types of connectors, surface mount device footprints, and rectangular waveguides. You can also create your own customized parts, and use them multiple times in the same or different models.

The part in this model describes a parameterized microstrip patch antenna geometry. Thereby you can easily change the geometry. The design parameters define the size of the substrate, patch radiator, feed line, and impedance matching geometry.

8-BY-4 FULL ANTENNA ARRAY

The full antenna array geometry is built with the customized part and array operation. The array substrate is enclosed by a surrounding air domain. All antenna elements are excited by lumped ports with the same default voltage and 50Ω reference impedance. The arithmetic phase values are used to steer the direction of the main radiation.

TABLE 1: ARITHMETIC PHASE FOR THE DIFFERENT LUMPED PORTS, IDENTIFIED BY THEIR LUMPED PORT NAME.

Arithmetic phase	Lumped port name
$-2\pi \cdot 0.48 \cdot \cos(\phi) \cdot 0$	1, 2, 3, 4
$-2\pi \cdot 0.48 \cdot \cos(\phi) \cdot 1$	5, 6, 7, 8
$-2\pi \cdot 0.48 \cdot \cos(\phi) \cdot 2$	9, 10, 11, 12
$-2\pi \cdot 0.48 \cdot \cos(\phi) \cdot 3$	13, 14, 15, 16
$-2\pi \cdot 0.48 \cdot \cos(\phi) \cdot 4$	17, 18, 19, 20
$-2\pi \cdot 0.48 \cdot \cos(\phi) \cdot 5$	21, 22, 23, 24
$-2\pi \cdot 0.48 \cdot \cos(\phi) \cdot 6$	25, 26, 27, 28
$-2\pi \cdot 0.48 \cdot \cos(\phi) \cdot 7$	29, 30, 31, 32

By running a parametric sweep of ϕ shown in [Table 1](#), the beam scanning capability of the phased array antenna can be evaluated.

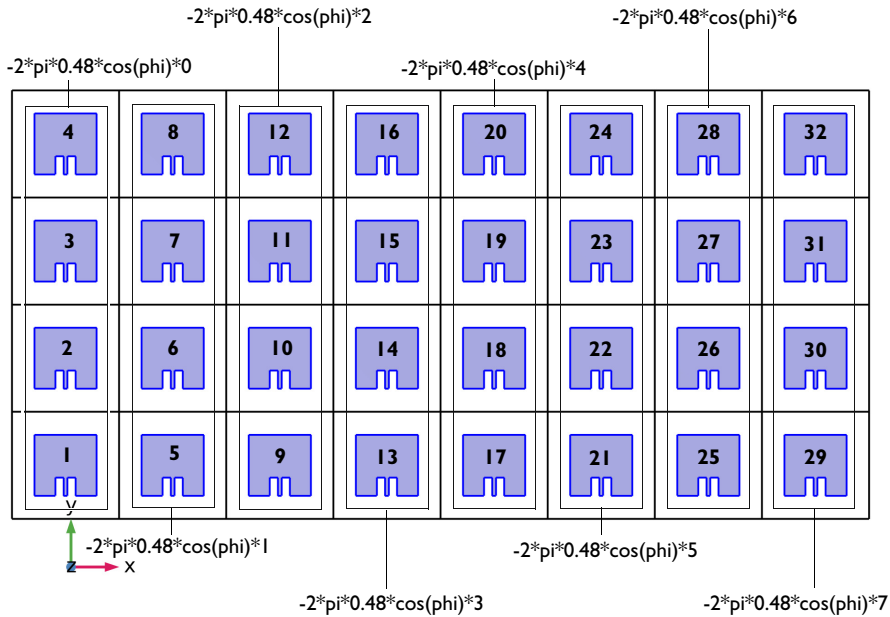

Figure 2: Lumped port phase configuration on the top view of the antenna array geometry.

For far-field analyses such as radiation pattern, gain, directivity, and effective isotropically radiated power (EIRP), a far-field domain and calculation features are required. It is important to apply the domain feature to the surrounding air domain or connected domains characterized by homogeneous material properties. The far-field calculation boundaries are the exterior boundaries of the far-field domain feature by default.

A perfect electric conductor (PEC) boundary condition is by default applied to the exterior boundaries of the simulation domain. In this model, that boundary condition is overridden by a first-order scattering boundary condition. The scattering boundary condition absorbs all outgoing radiation from the antenna.

The simulation frequency is not high enough to consider the loss coming from the finite conductivity of the copper layers. All metal boundaries are defined using the perfect electric conductor (PEC). The 60 mil dielectric substrate is assumed to be lossless and the relative permittivity, dielectric constant of the material is 3.38 in this model.

SIMPLIFIED MODEL USING PERIODIC CONDITIONS

The complexity of the full antenna array model can be reduced using periodic conditions and it is possible to estimate the far-field radiation pattern of the full antenna array efficiently by utilizing the built-in array factor function.

The periodic conditions are the core features virtually making the unit cell as an infinite array and simplify the original model for the faster analysis. Each periodic condition has a pair of boundary selections facing each other that can be identified as the source and destination boundaries, respectively. Four side boundaries are configured in two periodic conditions. The Floquet periodicity correlates the source and destination boundaries with a user-specified phase in terms of k -vector. The k -vector for Floquet periodicity is extracted using the direction of the main beam steered by the arithmetic phase progression. The beam is steered only around the y -axis. So the Floquet periodicity type is used for the periodic condition in which the selections are normal to the x -axis. In the other periodic condition where the boundaries are normal to the y -axis, the Continuity type is appropriate because no phase variation is expected between the source and the destination boundaries.

The top of the simulation domain is covered by a scattering boundary condition to model the surface as open space. The far-field domain feature is used only in the top air domain. This is a very special case not following the rule of thumb regarding the proper usage of the far-field feature. The basic assumptions here are that

- The far-field calculation is dominated by the selected boundaries.
- The unit cell antenna has a directive radiation pattern dominantly toward the air domain direction from the antenna. The front-to-back ratio of the radiation pattern is high.
- The radiation toward the bottom ground is not of interest.

Even if these conditions are fulfilled, this approach has to be carefully applied. In this example, the computed results are compared to those of the full array model and accepted as an alternative method for evaluating the performance of the antenna array for the given design.

Though the unit cell simulation includes the coupling by the adjacent surrounding array elements through the periodic conditions, the far-field transformation is performed only with the unit cell. The computed far-field radiation pattern does not describe that of the complete array. The desired radiation pattern of the array can be approximated by multiplying an array factor to the far field of the single antenna.

The 3D full-wave simulation for an antenna array is memory intensive. By using an asymptotic approach, such as multiplying the far-field of a single antenna with a uniform array factor, the radiation pattern of an antenna array can be evaluated quickly.

The 3D uniform array factor function is available under **Definitions > Functions** from the postprocessing context menu when a Far-Field Calculation feature is defined in the physics interface. The function call signature is

$$\text{af3}(\text{nx}, \text{ny}, \text{nz}, \text{dx}, \text{dy}, \text{dz}, \text{alphax}, \text{alphay}, \text{alphaz}),$$

where nx , ny , and nz are the number of elements along the x -, y -, and z -axis, respectively. The arguments dx , dy , and dz are the distances between array elements in terms of wavelength. alphax , alphay , and alphaz are the phase progression in radians.

To evaluate the realized gain of a virtual 8-by-4 antenna array from that of a single antenna, where all 32 elements are excited, the following expression is used:

$$\text{emw2.rGainBEfar} + 20 * \log_{10}(\text{emw2.af3}(8, 4, 1, 0.48, 0.48, 0, -2 * \pi * 0.48 * \cos(\text{phi}), 0, 0)) + 10 * \log_{10}(1/32)$$

Since it is the dB scale, the multiplication of the array factor represents a summation in the expression.

TABLE 2: INPUT PARAMETERS OF ARRAY FACTOR OPERATOR FOR AN 8-BY-4 ARRAY.

Parameter	Description	Argument	Unit
nx	Number of elements along x -axis	8	Dimensionless
ny	Number of elements along y -axis	4	Dimensionless
nz	Number of elements along z -axis	1	Dimensionless
dx	Distance between array elements along x -axis	0.48	Wavelength
dy	Distance between array elements along y -axis	0.48	Wavelength
dz	Distance between array elements along z -axis	0	Wavelength
alphax	Phase progression along x -axis	$-2 * \pi * 0.48 * \cos(\text{phi})$	Radian
alphay	Phase progression along y -axis	0	Radian
alphaz	Phase progression along z -axis	0	Radian

This expression arises from the pattern multiplication using the array factor, such as the single antenna's normEfar multiplied by the array factor af3 . Therefore, the realized gain of the virtual 8-by-4 antenna array is emw2.rGainEfar multiplied by $(\text{af3})^2/32$. Here, $(\text{af3})^2$ accounts for the pattern multiplication affecting radiation intensity, and 32

adjusts the single antenna's input power proportional to the number of array elements when all 32 elements are excited simultaneously. The logarithmic form of this expression corresponds to $\text{emw2.rGaindBefar} + 20 * \log_{10}(\text{emw2.af3}(8, 4, 1, 0.48, 0.48, 0, -2 * \pi * 0.48 * \cos(\text{phi}), 0, 0)) + 10 * \log_{10}(1/32)$.

The direction of the main beam can be steered by defining nonzero phase progression in the uniform array factor. The maximum radiation direction of the array factor along the x -axis is defined by the angle ϕ from the x -axis in the phase progression using

$$\alpha_x = -kd \cos \phi = -(2\pi d / \lambda) \cos \phi$$

The antenna is excited by a uniform lumped port. The lumped port is proper to use on a small boundary where a constant phase is expected over the port boundary.

Results and Discussion

Figure 3 visualizes the electric field norm when all antenna elements are excited with the same voltage, but the arithmetic phase progression is set to have the maximum radiation direction tilted from the z -axis. Strong field intensity is observed around the radiating edges of the patch antennas. Since the norm is plotted, the phase variation is not shown.

To see the field variation at each column of the array, a complex-valued field component, E_z , is used in Figure 4. Only the real part of complex values is plotted.

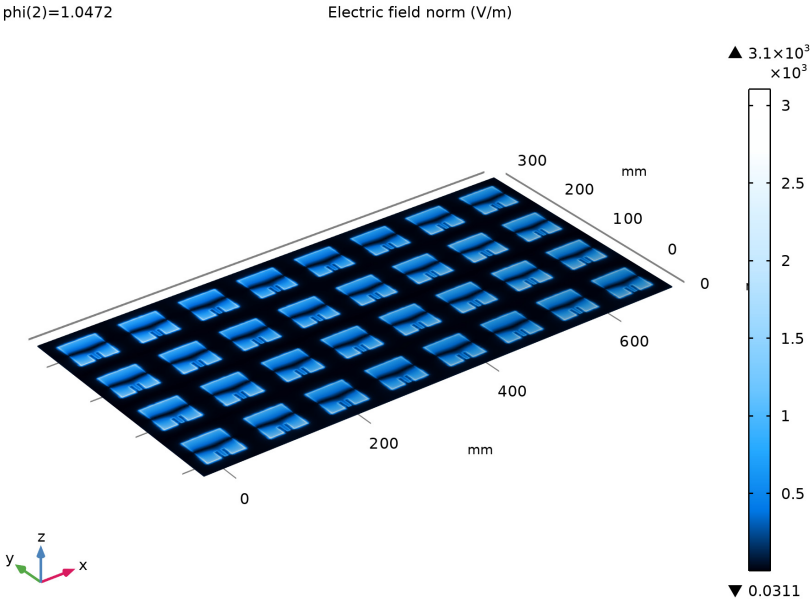

Figure 3: Electric field norm is plotted on the top surface on the antenna array board using a selection subfeature.

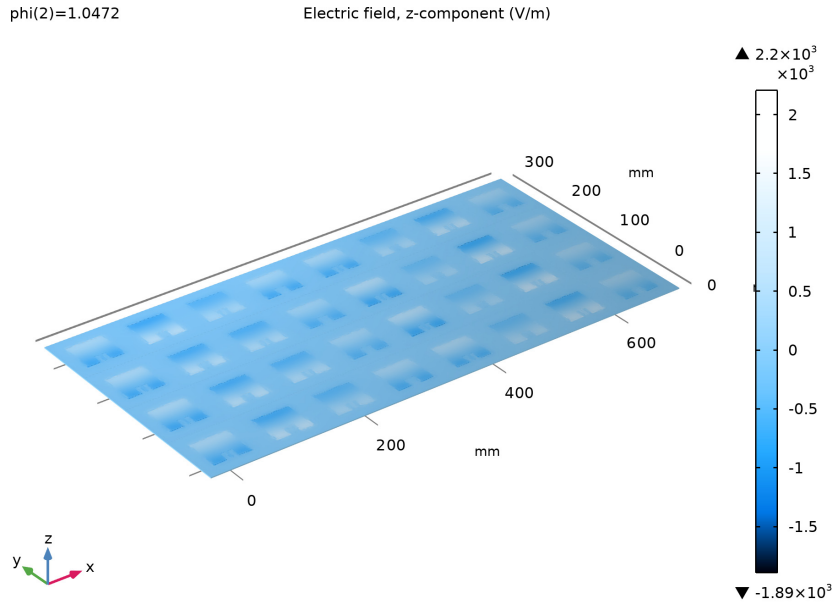

Figure 4: E_z plot showing the color variation at each array column.

TABLE 3: LUMPED PORT PHASE WHEN PHI IS $\pi/3$.

Arithmetic phase (degrees)	Array column group Index	Lumped port name
0	1	1, 2, 3, 4
-86.4	2	5, 6, 7, 8
-172.8	3	9, 10, 11, 12
-259.2	4	13, 14, 15, 16
-345.6	5	17, 18, 19, 20
432	6	21, 22, 23, 24
-518.4	7	25, 26, 27, 28
-604.8	8	29, 30, 31, 32

Figure 5 visualizes the far-field radiation pattern in a polar plot. The polar plot format is convenient for checking intuitively the directional properties of an antenna. When there is

no phase difference among the excitation ports and all antenna elements are uniformly fed, the generated radiation pattern is normal to the array plane (blue in Figure 5). Though the phase at each port is defined as $-2\pi \cdot 0.48 \cdot \cos(\phi)$, the input argument is effectively zero with a parameter ϕ value of $\pi/2$. When ϕ is $\pi/3$, the arithmetic phase applied to each array column group is listed in Table 3.

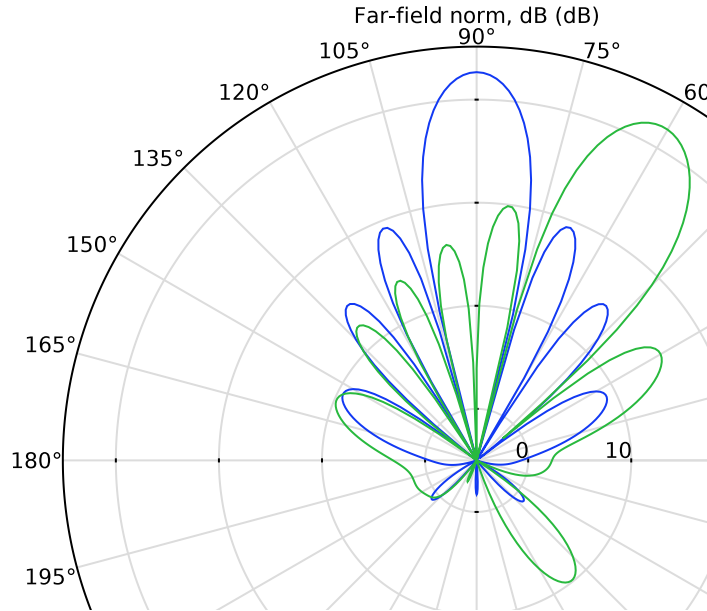

Figure 5: Far-field polar plot in dB scale for two cases: the beam steering angle at $\phi = \pi/2$ and $\pi/3$, respectively. When all antenna elements are excited by lumped ports with equal magnitude and zero phases, the main radiation is toward the antenna boresight (blue). When the arithmetic phase progression is applied, the beam can be steered (green).

A reasonably well-designed antenna array may have sidelobe levels below -10 dB which is not conspicuous when they are plotted in linear scale. The dB scale used in the polar plot and 3D far-field radiation pattern (Figure 6) makes the sidelobes more visible. For high-gain antennas, it is recommended to use a finer resolution for the radiation pattern visualization to characterize nulls and sidelobes without missing them. The number of angles in the settings window controls the resolution.

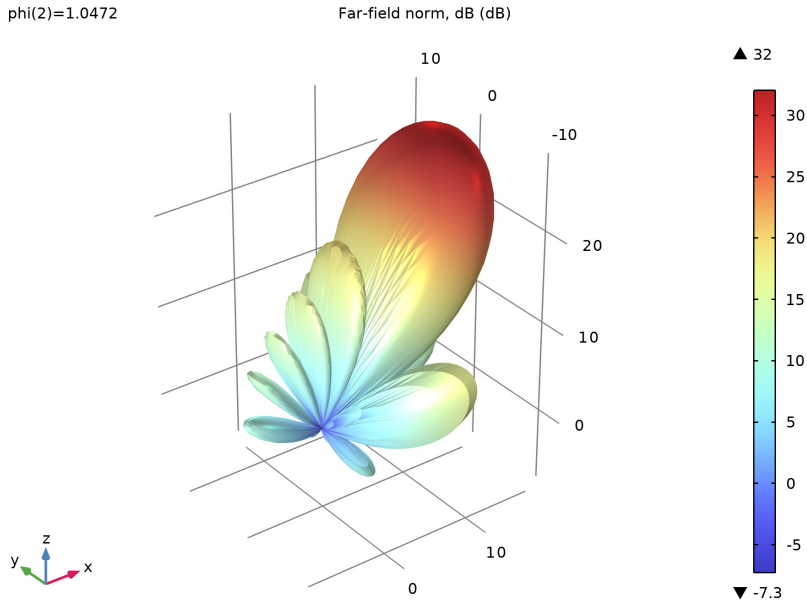

Figure 6: 3D far-field radiation pattern. The main beam direction is tilted from $\pi/3$ from the array plane.

The antenna performance for the simplified model is compared to that of the 8-by-4 full array model in [Figure 7](#). The main beam and several sidelobes for both straight and tilted beam cases of the simplified model coincide in angle and level with the results of the full array model. However, there is a noticeable discrepancy in the backward radiation—those below the ground plane. So, this reduced model using the periodic conditions is valid only when approximating the antenna boresight radiation.

[Figure 8](#) shows a similar type of comparison but using the realized gain in the 1D plot. As stated above, a good agreement is observed between two modeling approaches regardless of the beam scanning angle if only the main beam and major sidelobes are of interest for the antenna analysis.

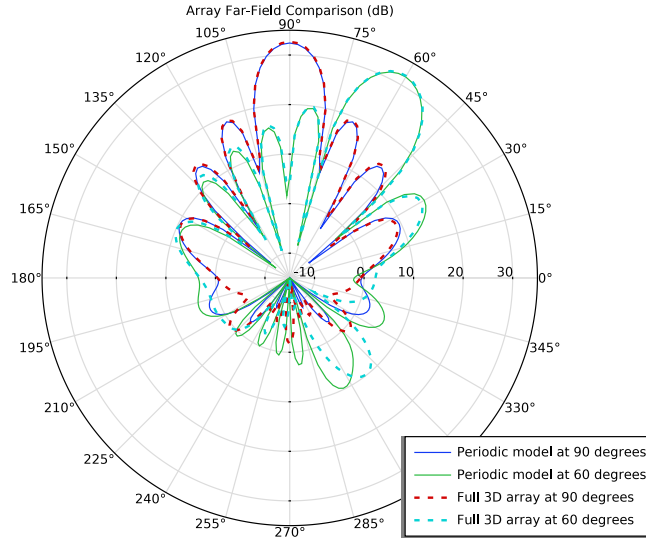

Figure 7: Gain comparison in a polar plot between two modeling methods. The main beam and sidelobe levels are agreed well.

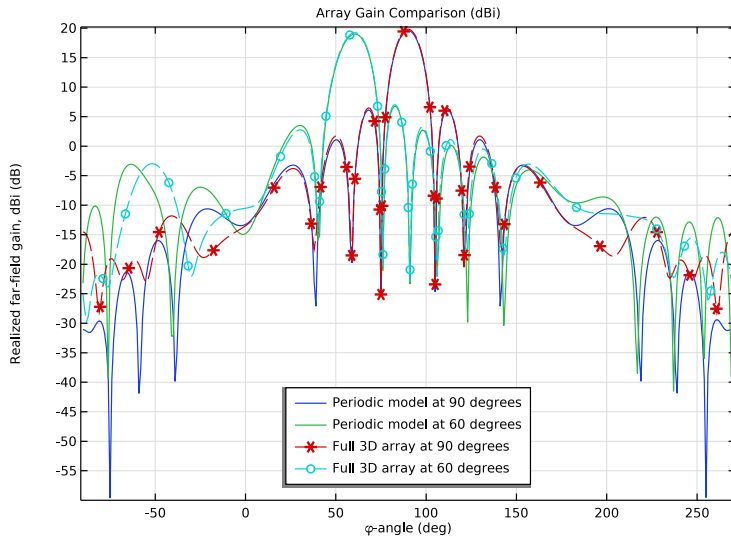

Figure 8: Gain comparison in a 1D plot. 1D plot perspective, different from the polar plot, provides a better view while observing nulls and backlobes.

Notes About the COMSOL Implementation

The first full model requires around 20 GB memory. It is advised to skip the computation and try the second reduced model if your memory resources are insufficient.

References

1. www.comsol.com/blogs/using-perfectly-matched-layers-and-scattering-boundary-conditions-for-wave-electromagnetics-problems
2. www.comsol.com/blogs/how-to-synthesize-the-radiation-pattern-of-an-antenna-array

Application Library path: RF_Module/Antenna_Arrays/
microstrip_patch_antenna_periodic

Modeling Instructions



This example consists of two simulations. One is a full 8-by-4 array model, while the other is simplified using periodic conditions. In both cases, the patch antenna geometry is repeatedly used. Therefore, it is convenient to build a part that can be added to the geometry as needed.

From the **File** menu, choose **New**.

NEW

In the **New** window, click  **Model Wizard**.

MODEL WIZARD

- 1 In the **Model Wizard** window, click  **3D**.
- 2 In the **Select Physics** tree, select **Radio Frequency > Electromagnetic Waves, Frequency Domain (emw)**.
- 3 Click **Add**.
- 4 Click  **Study**.
- 5 In the **Select Study** tree, select **General Studies > Frequency Domain**.
- 6 Click  **Done**.

GLOBAL DEFINITIONS

Parameters 1

- 1 In the **Model Builder** window, under **Global Definitions** click **Parameters 1**.
- 2 In the **Settings** window for **Parameters**, locate the **Parameters** section.
- 3 In the table, enter the following settings:

Name	Expression	Value	Description
d	60[mil]	0.001524 m	Substrate thickness
f0	1.575[GHz]	1.575E9 Hz	Center frequency
lda0	c_const/f0	0.19034 m	Wavelength
lda048	0.48*lda0	0.091365 m	0.48 Wavelengths
phi	pi/2	1.5708	Steering angle

The unit mil, used for substrate thickness, refers to milliinch. c_const is a predefined COMSOL constant for the speed of light in vacuum.

Antenna Geometry Part

PATCH ANTENNA

- 1 In the **Model Builder** window, right-click **Global Definitions** and choose **Geometry Parts > 3D Part**.
- 2 In the **Settings** window for **Part**, type Patch Antenna in the **Label** text field.
- 3 Locate the **Units** section. From the **Length unit** list, choose **mm**.
- 4 Locate the **Input Parameters** section. In the table, enter the following settings:

Name	Default expression	Value	Description
w_line	3.2[mm]	3.2 mm	50 ohm line width
w_patch	53[mm]	53 mm	Patch width
l_patch	52[mm]	52 mm	Patch length
w_stub	7[mm]	7 mm	Tuning stub width
l_stub	15.5[mm]	15.5 mm	Tuning stub length
w_sub	lda048	91.365 mm	Substrate width
l_sub	lda048	91.365 mm	Substrate length

The 50-ohm microstrip line width is defined by the thickness and dielectric constant of the substrate. These parameters have to be properly adjusted when using a different

substrate for the antenna design. The size of a single antenna unit is based on the array periodicity. We use 0.48 wavelengths in free space to have a relatively high gain and low side lobes.

Substrate

- 1 In the **Geometry** toolbar, click  **Block**.
- 2 In the **Settings** window for **Block**, type `Substrate` in the **Label** text field.
- 3 Locate the **Size and Shape** section. In the **Width** text field, type `w_sub`.
- 4 In the **Depth** text field, type `l_sub`.
- 5 In the **Height** text field, type `d`.
- 6 Locate the **Position** section. From the **Base** list, choose **Center**.

Patch

- 1 In the **Geometry** toolbar, click  **Block**.
- 2 In the **Settings** window for **Block**, locate the **Size and Shape** section.
- 3 In the **Width** text field, type `w_patch`.
- 4 In the **Depth** text field, type `l_patch`.
- 5 In the **Height** text field, type `d`.
- 6 Locate the **Position** section. From the **Base** list, choose **Center**.
- 7 In the **Label** text field, type `Patch`.

Stub

- 1 In the **Geometry** toolbar, click  **Block**.
- 2 In the **Settings** window for **Block**, type `Stub` in the **Label** text field.
- 3 Locate the **Size and Shape** section. In the **Width** text field, type `w_stub`.
- 4 In the **Depth** text field, type `l_stub`.
- 5 In the **Height** text field, type `d`.
- 6 Locate the **Position** section. From the **Base** list, choose **Center**.
- 7 In the **x** text field, type `w_stub/2+w_line/2`.
- 8 In the **y** text field, type `l_stub/2-l_patch/2`.

Copy 1 (copy1)

- 1 In the **Geometry** toolbar, click  **Transforms** and choose **Copy**.
- 2 Select the object `blk3` only.
- 3 In the **Settings** window for **Copy**, locate the **Displacement** section.

4 In the **x** text field, type `-w_stub-w_line`.

5 Click  **Build Selected**.

Difference 1 (dif1)

1 In the **Geometry** toolbar, click  **Booleans and Partitions** and choose **Difference**.

2 Select the object **blk2** only.

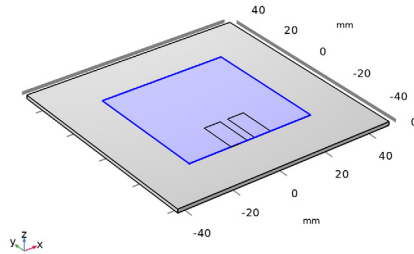

3 In the **Settings** window for **Difference**, locate the **Difference** section.

4 Click to select the  **Activate Selection** toggle button for **Objects to subtract**.

5 Select the objects **blk3** and **copy1** only.

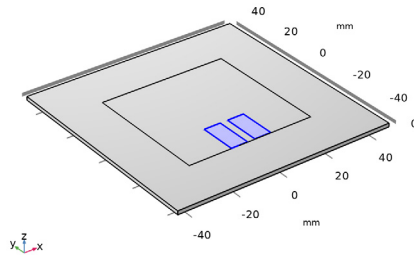

Truncating the rectangular patch with two small pieces of rectangular blocks creates an antenna feed line and an appropriate feeding point inside the patch without adding an impedance matching network. The characteristic impedance of this microstrip line is about 50 ohm.

Union 1 (un1)

1 In the **Geometry** toolbar, click  **Booleans and Partitions** and choose **Union**.

2 Click in the **Graphics** window and then press **Ctrl+A** to select both objects.

3 In the **Geometry** toolbar, click  **Build All**.

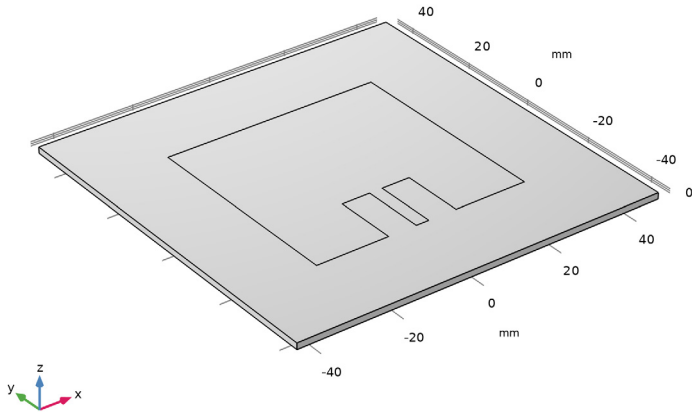

8-by-4 Full Antenna Array

GEOMETRY I

1 In the **Model Builder** window, under **Component 1 (comp1)** click **Geometry 1**.

2 In the **Settings** window for **Geometry**, locate the **Units** section.

3 From the **Length unit** list, choose **mm**.

The first full array model may require more than 20 GB of memory. If your computational resources are not sufficient, skip the full array model and continue from the section [Simplified Model Using Periodic Conditions](#). You can download the solved model via **Help** > **Update COMSOL Application Libraries**.

Add the antenna geometry from the part.

Patch Antenna 1 (pa1)

In the **Geometry** toolbar, click  **Part Instance** and choose **Patch Antenna**.

Add a block for the air domain.

Block 1 (blk1)

1 In the **Geometry** toolbar, click  **Block**.

2 Click the  **Go to Default View** button in the **Graphics** toolbar.

- 3 In the **Settings** window for **Block**, locate the **Size and Shape** section.
- 4 In the **Width** text field, type $1\text{da}048*9$.
- 5 In the **Depth** text field, type $1\text{da}048*5$.
- 6 In the **Height** text field, type 160.
- 7 Locate the **Position** section. In the **x** text field, type $-1\text{da}048$.
- 8 In the **y** text field, type $-1\text{da}048$.
- 9 In the **z** text field, type $-160/2+50$.
- 10 Click  **Build All Objects**.



Using **Wireframe** rendering provides the view of interior.

- 11 Click the  **Wireframe Rendering** button in the **Graphics** toolbar.

MATERIALS

Add a built-in air material for the entire simulation domain.

ADD MATERIAL

- 1 In the **Materials** toolbar, click  **Add Material** to open the **Add Material** window.
- 2 Go to the **Add Material** window.
- 3 In the tree, select **Built-in > Air**.
- 4 Click the **Add to Component** button in the window toolbar.
- 5 In the **Materials** toolbar, click  **Add Material** to close the **Add Material** window.

MATERIALS

Override the substrate domain with a dielectric material, where the relative permittivity is set to 3.38.

Substrate

- 1 In the **Model Builder** window, under **Component 1 (compl)** right-click **Materials** and choose **Blank Material**.
- 2 In the **Settings** window for **Material**, type Substrate in the **Label** text field.

3 Select Domains 2 and 3 only.

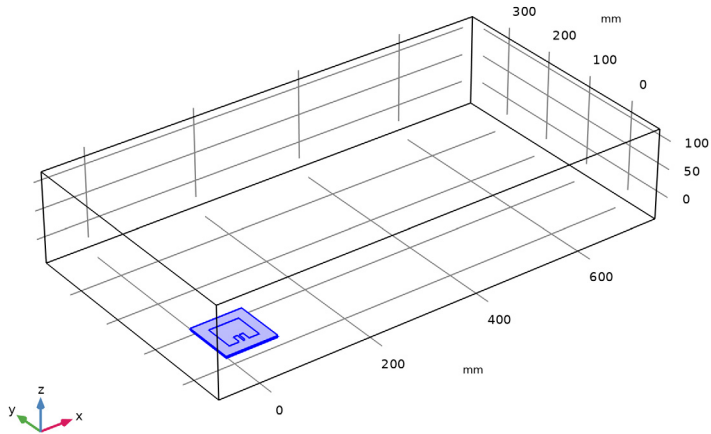

4 Locate the **Material Contents** section. In the table, enter the following settings:

Property	Variable	Value	Unit	Property group
Relative permittivity	epsilon_lr_iso ; epsilon_lr_ii = epsilon_lr_iso, epsilon_lr_ij = 0	3.38		Basic
Relative permeability	mu_r_iso ; mu_r_ii = mu_r_iso, mu_r_ij = 0	1		Basic
Electric conductivity	sigma_iso ; sigma_ii = sigma_iso, sigma_ij = 0	0	S/m	Basic

ELECTROMAGNETIC WAVES, FREQUENCY DOMAIN (EMW)

Lumped Port 1

- 1 In the **Physics** toolbar, click  **Boundaries** and choose **Lumped Port**.
- 2 Select Boundary 19 only.
- 3 In the **Settings** window for **Lumped Port**, locate the **Settings** section.

4 In the θ_{in} text field, type $-2\pi*0.48*\cos(\phi)*x/1da048$.

The expression outlined above facilitates the achievement of arithmetic phase progression along the x -axis within the phased array system. The factor $x/1da048$ in the port phase expression corresponds to the array column index N ranging from 1 to 8 when a complete array is constructed. Here, x represents the x -coordinate value of the lumped port boundary selection.

When ϕ represents the angle of maximum radiation measured from the array plane, the phase is conventionally defined as $2\pi*(\text{distance between array elements in wavelength})*\cos\phi*(N-1)$.

Perfect Electric Conductor 2

- 1 In the **Physics** toolbar, click  **Boundaries** and choose **Perfect Electric Conductor**.
- 2 Select Boundaries 8 and 13 only.



Perfect Electric Conductor 3

- 1 In the **Physics** toolbar, click  **Boundaries** and choose **Perfect Electric Conductor**.
- 2 Select Boundary 14 only.

GEOMETRY I

Create an 8-by-4 array using an **Array** feature. The array displacement corresponds to the single antenna size defined in the part.

Array 1 (arr1)

- 1 In the **Geometry** toolbar, click  **Transforms** and choose **Array**.
- 2 Select the object **pill** only.
- 3 In the **Settings** window for **Array**, locate the **Size** section.
- 4 In the **x size** text field, type 8.
- 5 In the **y size** text field, type 4.
- 6 Locate the **Displacement** section. In the **x** text field, type 1da048.
- 7 In the **y** text field, type 1da048.
- 8 Click  **Build Selected**.

9 Click the  **Zoom Extends** button in the **Graphics** toolbar.

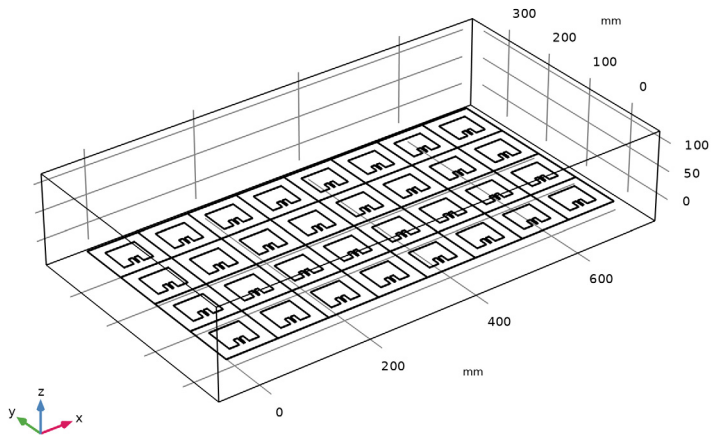

ELECTROMAGNETIC WAVES, FREQUENCY DOMAIN (EMW)

Lumped Port 1

Add a total of 32 **Lumped Port** features. All lumped ports are excited with equal voltage while the port phase in each column of the array increases arithmetically as a function of the angle from the array plane. The arithmetic phase variation results in the direction of maximum radiation steered from the normal axis of the array plane.

- 1 In the **Model Builder** window, under **Component 1 (comp1) > Electromagnetic Waves, Frequency Domain (emw)** click **Lumped Port 1**.

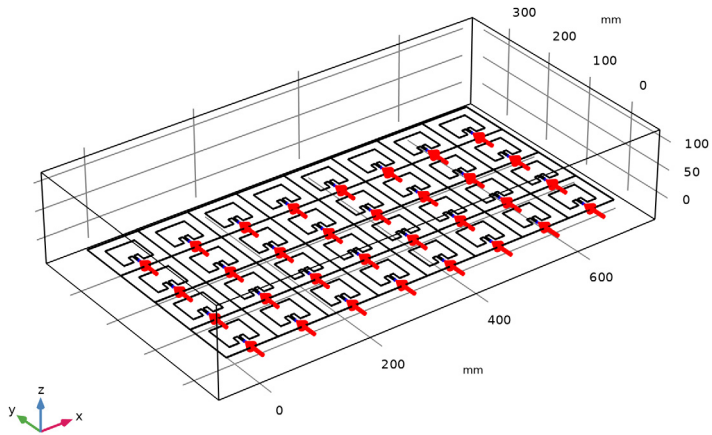

- 2 In the **Settings** window for **Lumped Port**, click the **Split by Connectivity** button in the window toolbar.

Lumped Port 5

In the **Model Builder** window, click **Lumped Port 5**.

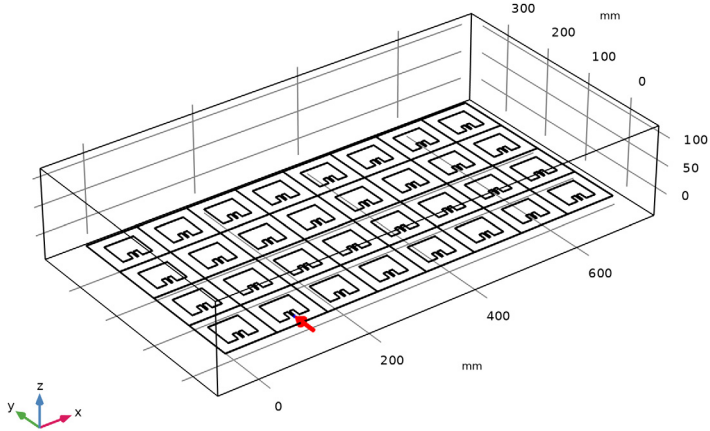

The phase of the lumped ports in the N th column is equivalently set to $-2\pi \cdot 0.48 \cdot \cos(\phi) \cdot (N-1)$, based on the value of the x -coordinate. Therefore, in this second column, the phase is $-2\pi \cdot 0.48 \cdot \cos(\phi) \cdot 1$.

A general expression for the port phase, scanning the main beam along the y -axis, can be given as $-2\pi \cdot 0.48 \cdot \cos(\phi) \cdot (y - l_{\text{patch}}/2) / l_{\text{da}048}$. It's important to note that the boundary for the first lumped port is not located at the origin but rather shifted by half of the patch length, where l_{patch} is defined within the patch antenna geometry part definition.

For 2-dimensional scanning, one can utilize the following expression: $2\pi \cdot 0.48 \cdot (\cos(\phi_x) \cdot x + \cos(\phi_y) \cdot (y - l_{\text{patch}}/2)) / l_{\text{da}048}$. It is necessary to define and use parameter ϕ_x and ϕ_y in the sweep accordingly.

Assign the first-order absorbing boundary condition, **Scattering Boundary Condition**, on the exterior boundaries. This mimics the absorbing walls of an anechoic chamber for antenna testing and characterization. For more accurate computations, the scattering boundary condition can be replaced by a **Perfectly Matched Layer** (PML). Detailed information regarding the performance of each feature can be found in the *RF Module Reference Manual* and in [Ref. 1](#).

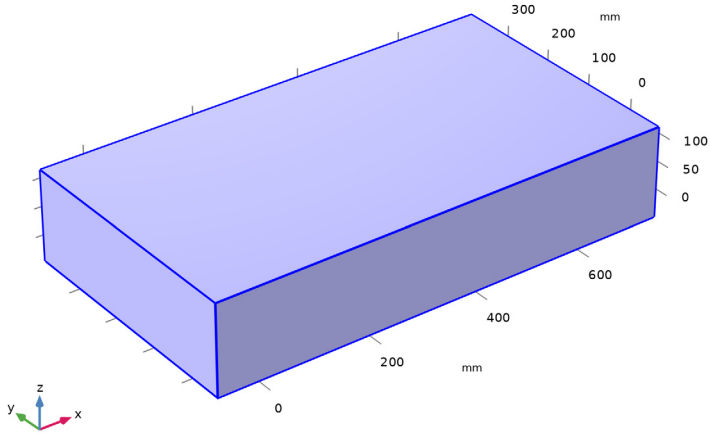

Scattering Boundary Condition 1

- 1 In the **Physics** toolbar, click  **Boundaries** and choose **Scattering Boundary Condition**.
- 2 Select Boundaries 1–5 and 594 only. These are all six exterior boundaries of the air domain.



Far-Field Domain and **Far-Field Calculation** features are used to compute the far-field radiation and gain patterns of the antenna array.

Far-Field Domain 1

- 1 In the **Physics** toolbar, click  **Domains** and choose **Far-Field Domain**.
The selection of the **Far-Field Domain** feature should include a homogeneous medium, such as the surrounding air domain, to compute the near-field to far-field transformation based on the Stratton–Chu formula.
- 2 In the **Settings** window for **Far-Field Domain**, locate the **Domain Selection** section.
- 3 Click  **Clear Selection**.

4 Select Domain 1 only.

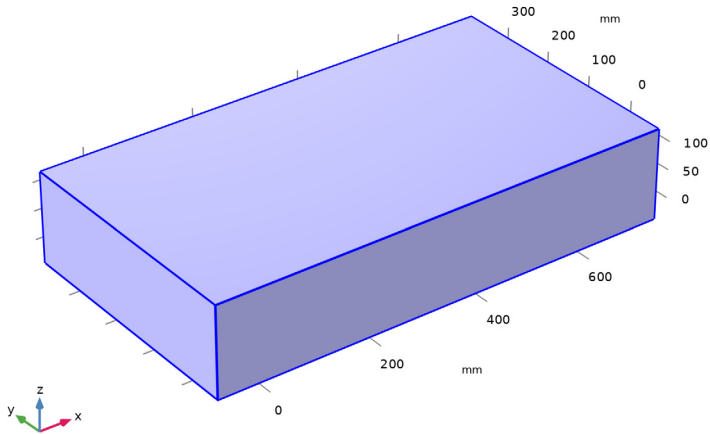

Far-Field Calculation 1

The selection of the **Far-Field Calculation** is automatically set on the exterior boundaries of the **Far-Field Domain**.

MATERIALS

Substrate (mat2)

- 1 In the **Model Builder** window, under **Component 1 (comp1) > Materials** click **Substrate (mat2)**.
- 2 In the **Settings** window for **Material**, locate the **Geometric Entity Selection** section.
- 3 Click  **Create Selection**.
- 4 In the **Create Selection** dialog, type Antenna Array Body in the **Selection name** text field.
- 5 Click **OK**.

STUDY 1 - FULL ARRAY

- 1 In the **Model Builder** window, click **Study 1**.
- 2 In the **Settings** window for **Study**, type Study 1 - Full Array in the **Label** text field.

Step 1: Frequency Domain

- 1 In the **Model Builder** window, under **Study 1 - Full Array** click **Step 1: Frequency Domain**.

- 2 In the **Settings** window for **Frequency Domain**, locate the **Study Settings** section.
- 3 In the **Frequencies** text field, type f_0 .

Parametric Sweep

- 1 In the **Study** toolbar, click  **Parametric Sweep**.
- 2 In the **Settings** window for **Parametric Sweep**, locate the **Study Settings** section.
- 3 Click **+ Add**.
- 4 In the table, enter the following settings:

Parameter name	Parameter value list	Parameter unit
phi (Steering angle)	pi/2 pi/3	

This will simulate the case where the main beam is normal to the array plane and tilted 30 degrees from the normal axis.

- 5 In the **Study** toolbar, click  **Compute**.

RESULTS

Multislice 1

- 1 In the **Model Builder** window, expand the **Results > Electric Field (emw)** node.
- 2 Right-click **Multislice 1** and choose **Delete**.

Electric Field (emw)

- 1 In the **Settings** window for **3D Plot Group**, locate the **Plot Settings** section.
- 2 Clear the **Plot dataset edges** checkbox.

This removes the black geometry edges when plotting the results under this plot group.



Surface 1

- 1 Right-click **Electric Field (emw)** and choose **Surface**.
- 2 In the **Settings** window for **Surface**, locate the **Coloring and Style** section.
- 3 From the **Color table** list, choose **JupiterAuroraBorealis**.

The **Selection** subfeature is useful for specifying the area of visualization. In this plot, we are interested in visualizing the electric field norm only on the top surface of the antenna substrate (Figure 3).

Selection 1

- 1 Right-click **Surface 1** and choose **Selection**.
- 2 In the **Settings** window for **Selection**, locate the **Selection** section.

- 3 From the **Geometric entity level** list, choose **Domain**.
- 4 From the **Selection** list, choose **Antenna Array Body**.
- 5 In the **Electric Field (emw)** toolbar, click  **Plot**.
- 6 Click the  **Zoom Extents** button in the **Graphics** toolbar.

$\phi(2)=1.0472$

Electric field norm (V/m)

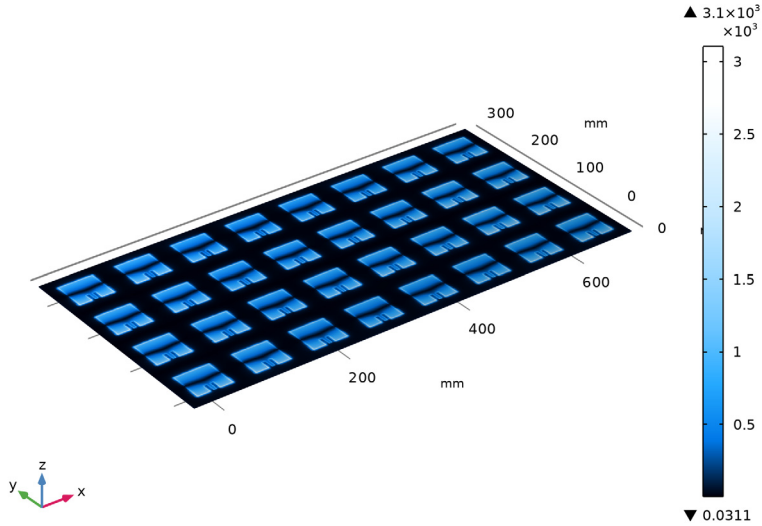

Surface 1

To see the field variation at each column of the array, plot the z -component of the electric field.

- 1 In the **Model Builder** window, click **Surface 1**.
- 2 In the **Settings** window for **Surface**, locate the **Expression** section.
- 3 In the **Expression** text field, type emw.Ez .

4 In the **Electric Field (emw)** toolbar, click  **Plot**.

Only the real part is plotted for complex values.

$\phi(2)=1.0472$

Electric field, z-component (V/m)

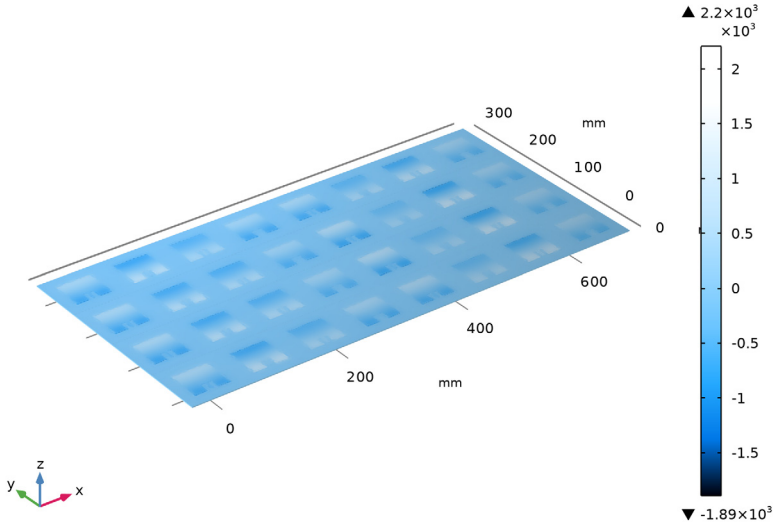

Electric Field, Logarithmic (emw)

In the **Model Builder** window, under **Results** click **Electric Field, Logarithmic (emw)**.

phi(2)=1.0472 Surface: 1 (1) Multislice: Electric field norm (V/m) Surface: Electric field norm (V/m)

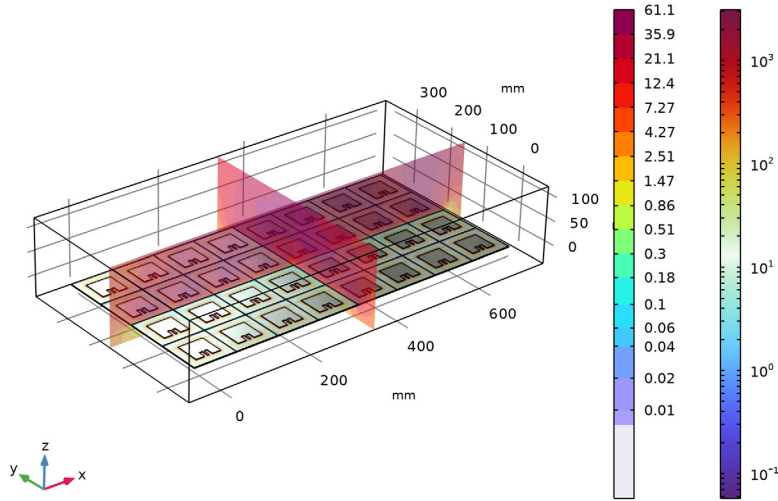

Now, plot the H-plane pattern (Figure 5) of the antenna array by adjusting the default polar plot settings. In this example, the main polarization of the radiated electric field from the microstrip patch antenna is parallel to the y-axis. When plotting the radiation patterns, E- and H-planes are conventionally used. The E-plane is the plane parallel to the antenna main polarization while the H-plane is perpendicular to that polarization. Here, the E-plane is the yz-plane, and the H-plane is the xz-plane.

Radiation Pattern 1

- 1 In the **Model Builder** window, expand the **Results > 2D Far Field (emw)** node, then click **Radiation Pattern 1**.
- 2 In the **Settings** window for **Radiation Pattern**, locate the **Expression** section.
- 3 In the **Expression** text field, type `emw.normdBefar`.
- 4 Locate the **Evaluation** section. Find the **Angles** subsection. In the **Number of angles** text field, type 360.
- 5 Find the **Normal vector** subsection. In the **y** text field, type -1.
- 6 In the **z** text field, type 0.
- 7 In the **2D Far Field (emw)** toolbar, click  **Plot**.

2D Far Field (emw)

- 1 In the **Model Builder** window, click **2D Far Field (emw)**.
- 2 In the **Settings** window for **Polar Plot Group**, locate the **Axis** section.
- 3 Select the **Manual axis limits** checkbox.
- 4 In the **r minimum** text field, type -5.

The minimum level in the polar plot may change the impression on the side lobe level and beamwidth.

- 5 In the **2D Far Field (emw)** toolbar, click  **Plot**.

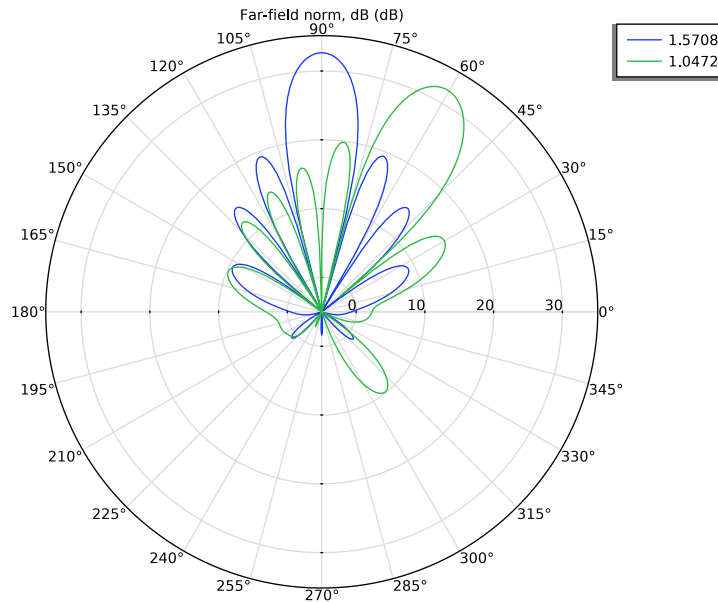

Radiation Pattern I

- 1 In the **Model Builder** window, expand the **Results > 3D Far Field, Gain (emw)** node, then click **Radiation Pattern I**.
- 2 In the **Settings** window for **Radiation Pattern**, locate the **Expression** section.
- 3 In the **Expression** text field, type `emw.normdBefar`.
- 4 Select the **Threshold** checkbox. In the associated text field, type 0.
- 5 Locate the **Evaluation** section. Find the **Angles** subsection. In the **Number of elevation angles** text field, type 90.

6 In the **Number of azimuth angles** text field, type 90.

The higher number of angles results in a finer angular resolution for the 3D far-field pattern.

7 In the **3D Far Field, Gain (emw)** toolbar, click  **Plot**.

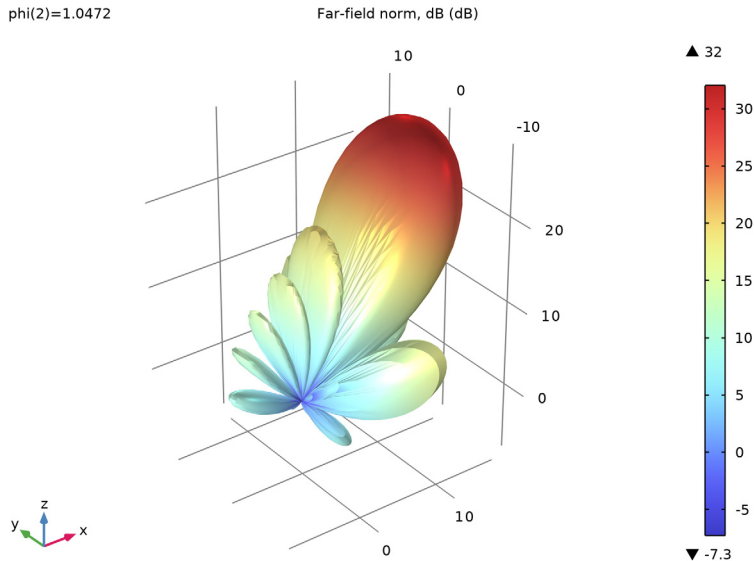

Simplified Model Using Periodic Conditions

The full array analysis is now completed. Build a new model for a simplified analysis using periodic conditions.

ADD COMPONENT

In the **Model Builder** window, right-click the root node and choose **Add Component > 3D**.

GEOMETRY 2

1 In the **Settings** window for **Geometry**, locate the **Units** section.

2 From the **Length unit** list, choose **mm**.





Add the antenna geometry from the part.

Patch Antenna 1 (pil)

In the **Geometry** toolbar, click  **Part Instance** and choose **Patch Antenna**.

Add a block on the top surface of the antenna.

Block 1 (blk1)

- 1 In the **Geometry** toolbar, click  **Block**.
- 2 In the **Settings** window for **Block**, locate the **Size and Shape** section.
- 3 In the **Width** text field, type 1da048.
- 4 In the **Depth** text field, type 1da048.
- 5 In the **Height** text field, type 80.
- 6 Locate the **Position** section. In the **z** text field, type 40-d/2.
- 7 From the **Base** list, choose **Center**.
- 8 Click  **Build All Objects**.
- 9 Click the  **Wireframe Rendering** button in the **Graphics** toolbar.
- 10 Click the  **Zoom Extents** button in the **Graphics** toolbar.

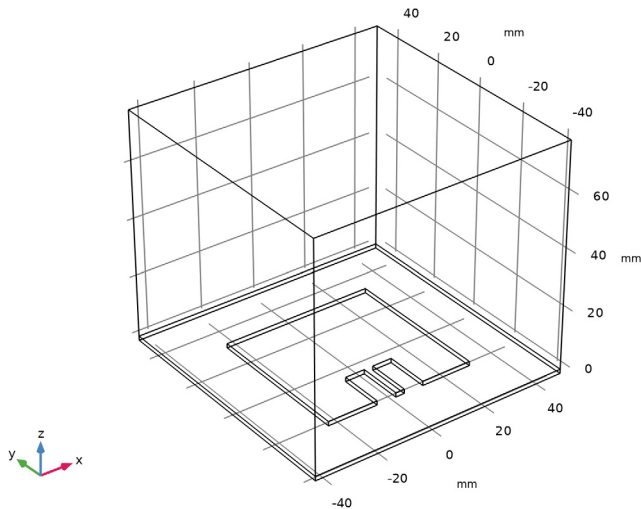



ADD PHYSICS

- 1 In the **Home** toolbar, click  **Add Physics** to open the **Add Physics** window.
- 2 Go to the **Add Physics** window.
- 3 In the tree, select **Radio Frequency** > **Electromagnetic Waves, Frequency Domain (emw)**.
- 4 Find the **Physics interfaces in study** subsection. In the table, clear the **Solve** checkbox for **Study 1 - Full Array**.

- 5 Click the **Add to Component 2** button in the window toolbar.
- 6 In the **Home** toolbar, click  **Add Physics** to close the **Add Physics** window.

ADD STUDY

- 1 In the **Home** toolbar, click  **Add Study** to open the **Add Study** window.
- 2 Go to the **Add Study** window.
- 3 Find the **Studies** subsection. In the **Select Study** tree, select **General Studies > Frequency Domain**.
- 4 Find the **Physics interfaces in study** subsection. In the table, clear the **Solve** checkbox for **Electromagnetic Waves, Frequency Domain (emw)**.
- 5 Click the **Add Study** button in the window toolbar.
- 6 In the **Home** toolbar, click  **Add Study** to close the **Add Study** window.

STUDY 2 - SIMPLIFIED



In the **Settings** window for **Study**, type Study 2 - Simplified in the **Label** text field.

Step 1: Frequency Domain

- 1 In the **Model Builder** window, under **Study 2 - Simplified** click **Step 1: Frequency Domain**.
- 2 In the **Settings** window for **Frequency Domain**, locate the **Study Settings** section.
- 3 In the **Frequencies** text field, type f_0 .

Add a built-in air material for the entire simulation domain and override the antenna substrate with the same dielectric material.

ADD MATERIAL

- 1 In the **Materials** toolbar, click  **Add Material** to open the **Add Material** window.
- 2 Go to the **Add Material** window.
- 3 In the tree, select **Built-in > Air**.
- 4 Click the **Add to Component** button in the window toolbar.
- 5 In the **Materials** toolbar, click  **Add Material** to close the **Add Material** window.

MATERIALS

Substrate

- 1 In the **Model Builder** window, under **Component 2 (comp2)** right-click **Materials** and choose **Blank Material**.
- 2 In the **Settings** window for **Material**, type Substrate in the **Label** text field.

3 Select Domains 1 and 3 only.

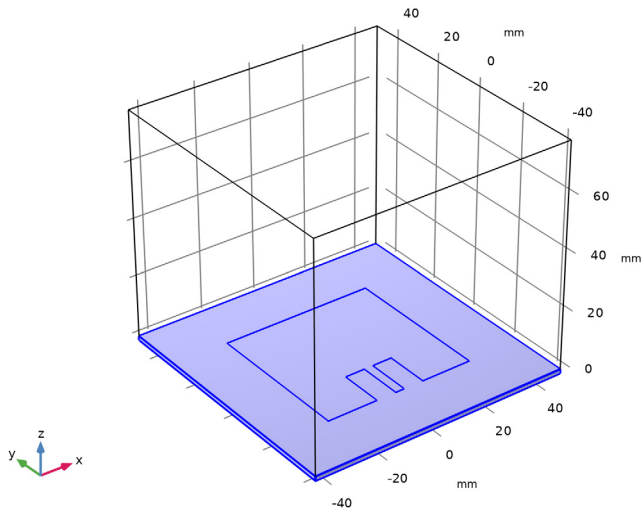

4 Locate the **Material Contents** section. In the table, enter the following settings:

Property	Variable	Value	Unit	Property group
Relative permittivity	epsilon _{nr_} iso ; epsilon _{nrii} = epsilon _{nr_} iso, epsilon _{nrij} = 0	3.38		Basic
Relative permeability	mu _{r_} iso ; mu _{rii} = mu _{r_} iso, mu _{rij} = 0	1		Basic
Electric conductivity	sigma _{iso} ; sigma _{ii} = sigma _{iso} , sigma _{ij} = 0	0	S/m	Basic

ELECTROMAGNETIC WAVES, FREQUENCY DOMAIN 2 (EMW2)

Lumped Port 1

1 In the **Physics** toolbar, click  **Boundaries** and choose **Lumped Port**.

2 Select Boundary 18 only.

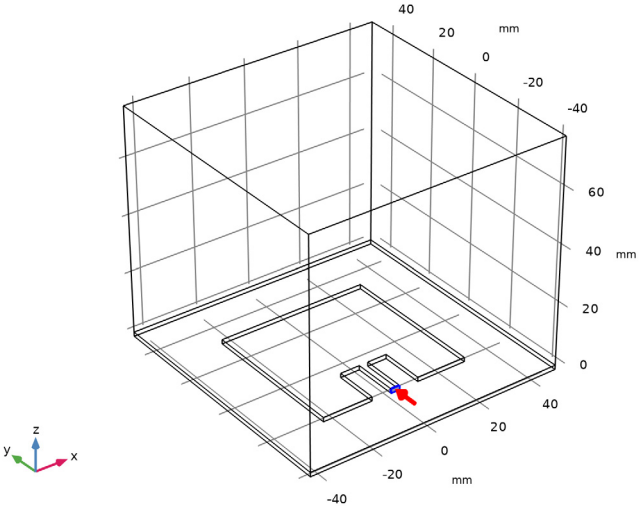

Perfect Electric Conductor 2

1 In the **Physics** toolbar, click  **Boundaries** and choose **Perfect Electric Conductor**.

2 Select Boundary 13 only.

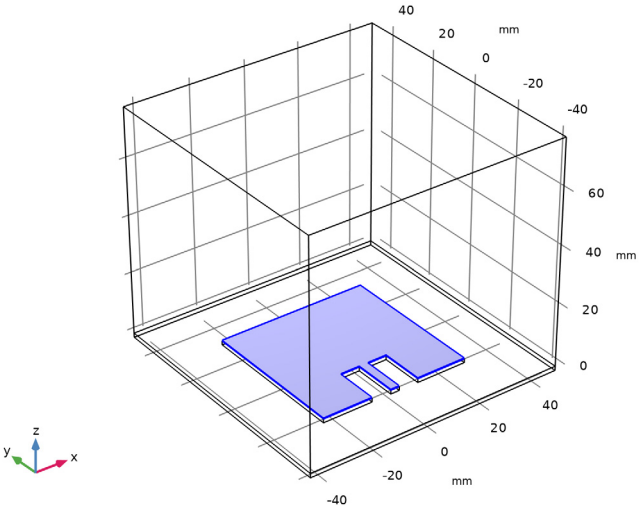

A **Periodic Condition** is the essence of the simplified array design. Assign this boundary condition to each facing pair of all exterior side boundaries.

This mimics an infinite array and the simulation includes the coupling effect with adjacent array elements.

Periodic Condition 1

- 1 In the **Physics** toolbar, click  **Boundaries** and choose **Periodic Condition**.
- 2 Select Boundaries 1, 4, 24, and 25 only.

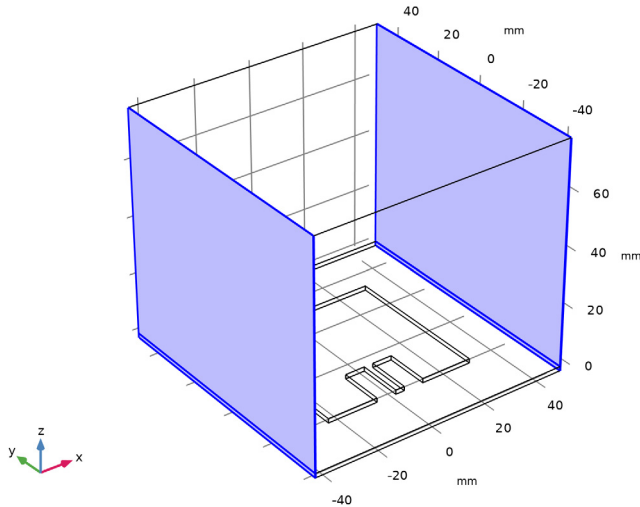

- 3 In the **Settings** window for **Periodic Condition**, locate the **Periodicity Settings** section.
- 4 From the **Type of periodicity** list, choose **Floquet periodicity**.
- 5 Specify the \mathbf{k}_F vector as

$emw2.k0*\cos(\phi)$	x
0	y
0	z

The **Floquet periodicity** type is useful when defining the phase relation between the source and destination boundaries with an arbitrary angle of incidence. It is characterized by a scaled wave number or a specific wave-vector component with respect to the direction from the source to destination boundaries. Here, we assume that the radiation through the main beam is dominant in the air domain and its angle is used to configure the **k-vector for Floquet periodicity**.

Periodic Condition 2

1 In the **Physics** toolbar, click  **Boundaries** and choose **Periodic Condition**.

The beam scanning happens only around the y -axis in the xz -plane. It is assumed that there is no phase variation between the source and destination boundaries normal to the y -axis. The default **Continuity** type of periodicity is used for those boundaries.

2 Select Boundaries 2, 5, 8, and 9 only.

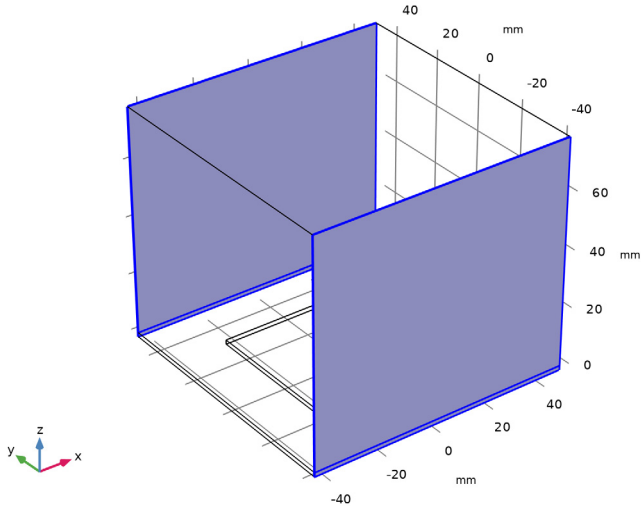



Scattering Boundary Condition 1

1 In the **Physics** toolbar, click  **Boundaries** and choose **Scattering Boundary Condition**.

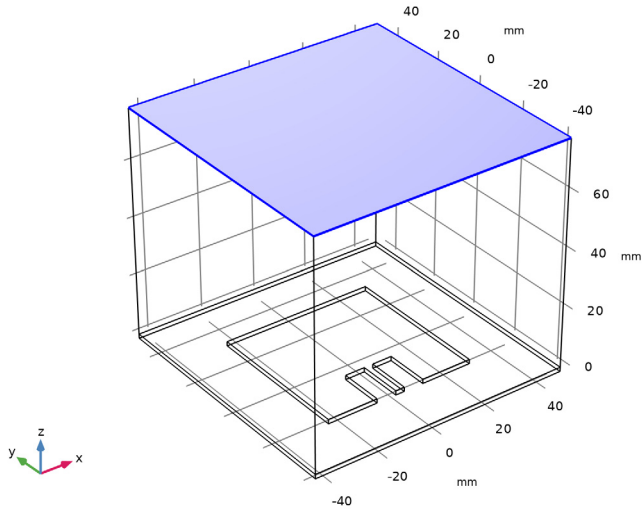
2 Select Boundary 7 only.



Far-Field Domain 1

- 1 In the **Physics** toolbar, click  **Domains** and choose **Far-Field Domain**.
- 2 In the **Settings** window for **Far-Field Domain**, locate the **Domain Selection** section.
- 3 Click  **Clear Selection**.
- 4 Select Domain 2 only.

Note that only the air domain is included in the **Far-Field Domain** feature. In general, the Far-Field Domain feature must be applied over the surrounding homogeneous medium. The usage in this example is exceptional in that it assumes that the radiation can be characterized sufficiently by the near field in the upper half-space air domain. The

current methodology is limited to fast approximation of the antenna array where the major radiation is neither bidirectional nor omnidirectional.

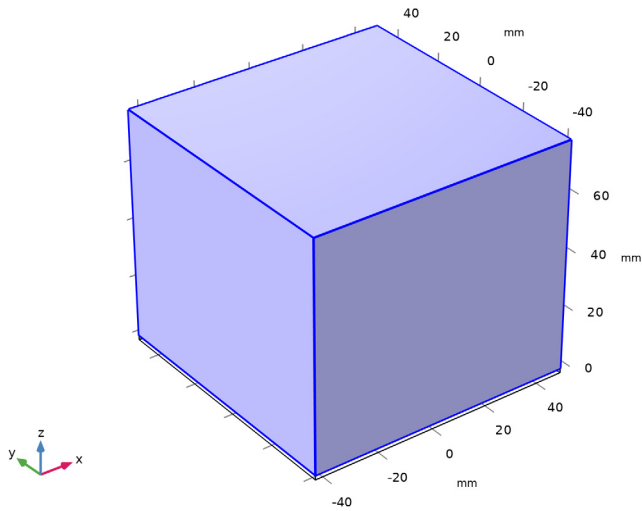

Far-Field Calculation 1

- 1 In the **Model Builder** window, expand the **Far-Field Domain 1** node, then click **Far-Field Calculation 1**.
- 2 In the **Settings** window for **Far-Field Calculation**, locate the **Boundary Selection** section.
- 3 Click  **Clear Selection**.

4 Select Boundaries 4, 5, 7, 9, and 25 only.

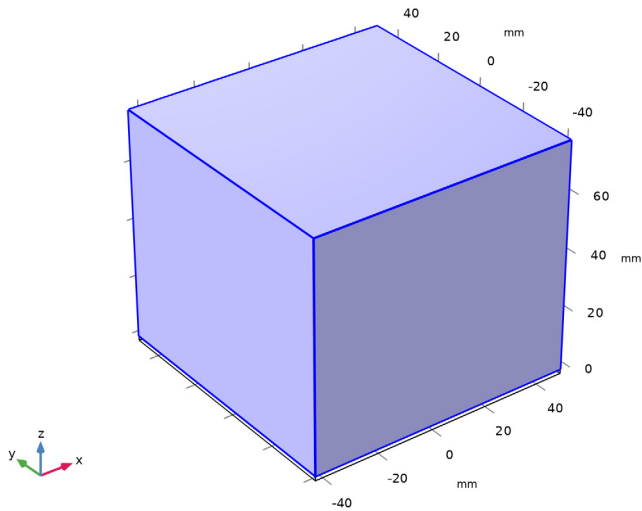

MESH 2

- 1 In the **Model Builder** window, under **Component 2 (comp2)** right-click **Mesh 2** and choose **Build All**.
- 2 Click the  **Click and Hide** button in the **Graphics** toolbar.
- 3 Select Boundary 5 only.
- 4 Select Boundary 7 only.

5 Click the  **Click and Hide** button in the **Graphics** toolbar.

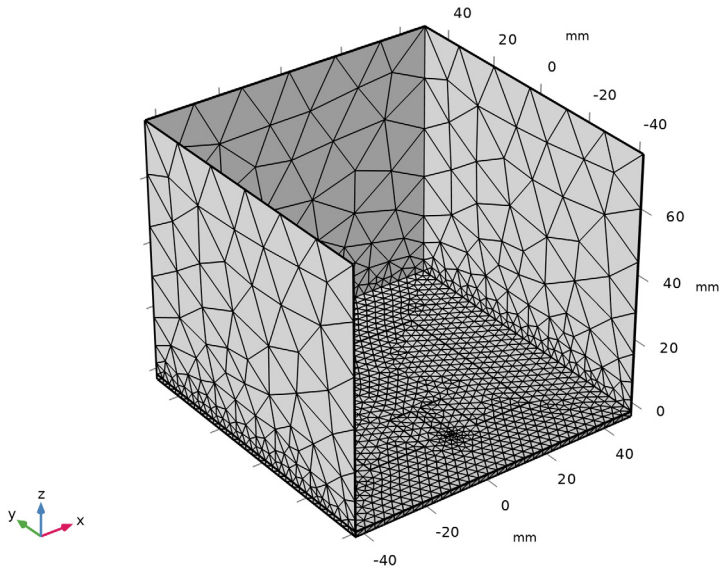

You might have noticed that the shape of the mesh in the specific pair of boundaries in the periodic condition is identical. The mesh sequences generated using a **Physics-controlled mesh** can be reviewed by switching the **Sequence type** from **Physics-controlled mesh** to **User-controlled mesh**, or by right-clicking on the **Mesh 2** node in the Model Builder and choosing **Edit Physics-Induced Sequence**.

STUDY 2 - SIMPLIFIED

Parametric Sweep

- 1 In the **Study** toolbar, click  **Parametric Sweep**.
- 2 In the **Settings** window for **Parametric Sweep**, locate the **Study Settings** section.
- 3 Click **+ Add**.
- 4 In the table, enter the following settings:

Parameter name	Parameter value list	Parameter unit
phi (Steering angle)	pi/2 pi/3	

- 5 In the **Study** toolbar, click  **Compute**.

RESULTS

Electric Field (emw2)

Adjust the default multislice plot settings to see the electric field norm in the substrate.

Multislice 1

- 1 In the **Model Builder** window, expand the **Electric Field (emw2)** node, then click **Multislice 1**.
- 2 In the **Settings** window for **Multislice**, locate the **Multipane Data** section.
- 3 Find the **X-planes** subsection. In the **Planes** text field, type 0.
- 4 Find the **Y-planes** subsection. In the **Planes** text field, type 0.
- 5 Find the **Z-planes** subsection. From the **Entry method** list, choose **Coordinates**.
- 6 In the **Coordinates** text field, type 0.
- 7 In the **Electric Field (emw2)** toolbar, click  **Plot**.

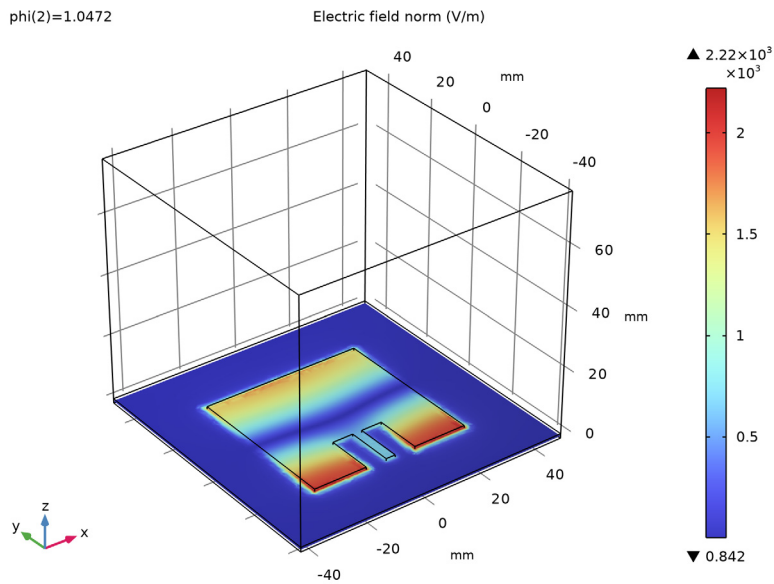

Electric Field, Logarithmic (emw2)

In the **Model Builder** window, under **Results** click **Electric Field, Logarithmic (emw2)**.

phi(2)=1.0472 Surface: 1 (1) Surface: 1 (1) Surface: Electric field norm (V/m) Multislice: Electric field norm (V/m) Surface: Electric field norm (V/m)

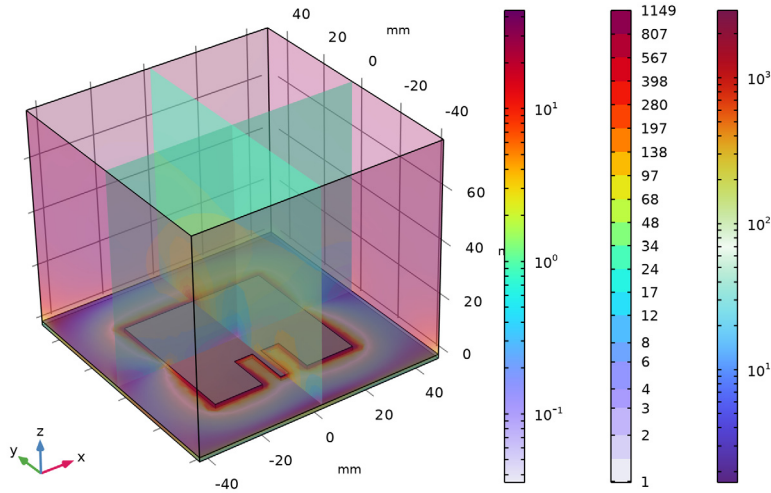

2D Far Field (emw2)

The default polar plot is the result of the far-field transformation of a single antenna affected by surrounding array elements. In order to show the radiation pattern (Figure 7) of the 8-by-4 antenna array, the corresponding array factor needs to be multiplied by the single antenna far-field pattern.

- 1 In the **Model Builder** window, click **2D Far Field (emw2)**.
- 2 In the **Settings** window for **Polar Plot Group**, click to expand the **Title** section.
- 3 From the **Title type** list, choose **Manual**.
- 4 In the **Title** text area, type Array Far-Field Comparison (dB).
- 5 Locate the **Axis** section. Select the **Manual axis limits** checkbox.
- 6 In the **r minimum** text field, type -15.
- 7 In the **r maximum** text field, type 35.
- 8 Locate the **Legend** section. From the **Position** list, choose **Lower right**.

Radiation Pattern 1

In dB scale, multiplication is represented by summation. The usage of an array factor is discussed in the [Model Definition](#) section and is also available from [Ref. 2](#).

- 1 In the **Model Builder** window, expand the **2D Far Field (emw2)** node, then click **Radiation Pattern 1**.
- 2 In the **Settings** window for **Radiation Pattern**, locate the **Expression** section.
- 3 In the **Expression** text field, type $\text{emw2.normdBefar}2+20*\log_{10}(\text{emw2.af}3(8,4,1,0.48,0.48,0,-2*\pi*0.48*\cos(\text{phi}),0,0))$.
- 4 Locate the **Evaluation** section. Find the **Normal vector** subsection. In the **y** text field, type -1.
- 5 In the **z** text field, type 0.
- 6 Click to expand the **Legends** section. From the **Legends** list, choose **Evaluated**.
- 7 In the **Legend** text field, type `Periodic model at eval(phi/pi*180) degrees`.

2D Far Field (emw2)

In the **Model Builder** window, click **2D Far Field (emw2)**.

Radiation Pattern 2

- 1 In the **2D Far Field (emw2)** toolbar, click  **More Plots** and choose **Radiation Pattern**.
- 2 In the **Settings** window for **Radiation Pattern**, locate the **Data** section.
- 3 From the **Dataset** list, choose **Study 1 - Full Array/Solution 1 (sol1)**.
- 4 Locate the **Expression** section. In the **Expression** text field, type emw.normdBefar .
- 5 Locate the **Evaluation** section. Find the **Angles** subsection. In the **Number of angles** text field, type 180.
- 6 Find the **Normal vector** subsection. In the **y** text field, type -1.
- 7 In the **z** text field, type 0.
- 8 Locate the **Legends** section. Select the **Show legends** checkbox.
- 9 From the **Legends** list, choose **Evaluated**.
- 10 In the **Legend** text field, type `Full 3D array at eval(phi/pi*180) degrees`.
- 11 Click to expand the **Coloring and Style** section. Find the **Line style** subsection. From the **Line** list, choose **Dotted**.
- 12 From the **Width** list, choose **2**.

13 In the **2D Far Field (emw2)** toolbar, click  **Plot**.

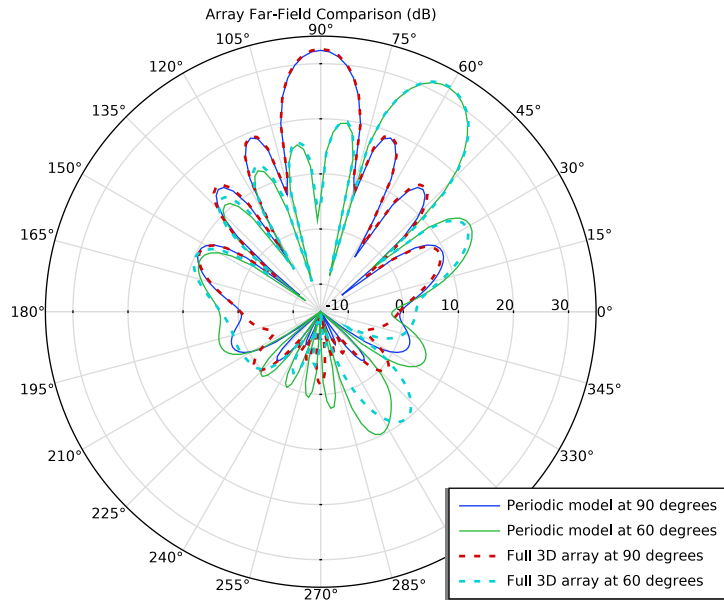

The comparison in the polar plot shows good agreement between the full array model and simplified model for the main beam and some side lobes.

Array Factor 1

- 1 In the **Results** toolbar, click  **More Datasets** and choose **Array Factor**.
- 2 In the **Settings** window for **Array Factor**, locate the **Data** section.
- 3 From the **Dataset** list, choose **Study 2 - Simplified/Solution 2 (3) (sol2)**.
- 4 Locate the **Array Definition** section. In row **Array size**, set **x** to 8.
- 5 In row **Array size**, set **y** to 4.
- 6 In row **Phase shift**, set **x** to $-2 \cdot \pi \cdot 0.48 \cdot \cos(\phi)$.
- 7 In row **Displacement**, set **x** to 0.48.
- 8 In row **Displacement**, set **y** to 0.48.
- 9 Locate the **Evaluation** section. In the **Function** text field, type `emw2.af3`.
- 10 From the **Scale** list, choose **dB**.
- 11 Select the **Normalization** checkbox.

Array Gain Comparison

1 In the **Results** toolbar, click  **ID Plot Group**.

The radiation pattern can also be plotted in a different format to inspect the level of nulls and side lobes with a wider plotting dynamic range. Reproduce the 1D plot (Figure 8) as follows.

- 2 In the **Settings** window for **ID Plot Group**, type Array Gain Comparison in the **Label** text field.
- 3 Click to expand the **Title** section. From the **Title type** list, choose **Manual**.
- 4 In the **Title** text area, type Array Gain Comparison (dBi).
- 5 Locate the **Legend** section. From the **Position** list, choose **Lower middle**.

Radiation Pattern I

1 In the **Array Gain Comparison** toolbar, click  **More Plots** and choose **Radiation Pattern**.

- 2 In the **Settings** window for **Radiation Pattern**, locate the **Data** section.
- 3 From the **Dataset** list, choose **Array Factor I**.
- 4 Locate the **Expression** section. In the **Expression** text field, type `emw2.rGaindBefar`.
- 5 Locate the **Evaluation** section. Find the **Angles** subsection. In the **Number of angles** text field, type 360.
- 6 From the **Restriction** list, choose **Manual**.
- 7 In the ϕ **start** text field, type -90.
- 8 Find the **Normal vector** subsection. In the **y** text field, type -1.
- 9 In the **z** text field, type 0.
- 10 Click to expand the **Legends** section. Select the **Show legends** checkbox.
- 11 From the **Legends** list, choose **Evaluated**.
- 12 In the **Legend** text field, type `Periodic model at eval(phi/pi*180) degrees`.
- 13 In the **Array Gain Comparison** toolbar, click  **Plot**.

Combined with the **Array Factor** dataset, the plot expression used above is equivalent to `emw2.rGaindBefar+20*log10(emw2.af3(8,4,1,0.48,0.48,0,-2*pi*0.48*cos(phi),0,0))+10*log10(1/32)`.

Array Gain Comparison

In the **Model Builder** window, click **Array Gain Comparison**.

Radiation Pattern 2

- 1** In the **Array Gain Comparison** toolbar, click  **More Plots** and choose **Radiation Pattern**.
- 2** In the **Settings** window for **Radiation Pattern**, locate the **Data** section.
- 3** From the **Dataset** list, choose **Study 1 - Full Array/Solution 1 (sol1)**.
- 4** Locate the **Expression** section. In the **Expression** text field, type `emw.rGaindBefar`.
- 5** Locate the **Evaluation** section. Find the **Angles** subsection. In the **Number of angles** text field, type 360.
- 6** From the **Restriction** list, choose **Manual**.
- 7** In the ϕ **start** text field, type -90.
- 8** Find the **Normal vector** subsection. In the **y** text field, type -1.
- 9** In the **z** text field, type 0.
- 10** Click to expand the **Coloring and Style** section. Find the **Line style** subsection. From the **Line** list, choose **Dashed**.
- 11** Find the **Line markers** subsection. From the **Marker** list, choose **Cycle**.
- 12** From the **Positioning** list, choose **Interpolated**.
- 13** In the **Number** text field, type 31.
- 14** Locate the **Legends** section. Select the **Show legends** checkbox.
- 15** From the **Legends** list, choose **Evaluated**.
- 16** In the **Legend** text field, type `Full 3D array at eval(phi/pi*180) degrees`.

17 In the **Array Gain Comparison** toolbar, click  **Plot**.

