



Model created in COMSOL Multiphysics 6.4

Modeling of Microstrip Lines with Vias

Introduction

There are multiple ways to excite and terminate transmission lines using different types of port and lumped port features. In this example, transverse electromagnetic (TEM) type ports and a via type lumped port are used to simulate two adjacent microstrip lines. One via end is terminated as a metalized via while the other via end is probing an inflow signal. The computed S-parameters show the amount of crosstalk between the lines and the strength of the signal coupled through the cylindrical via.

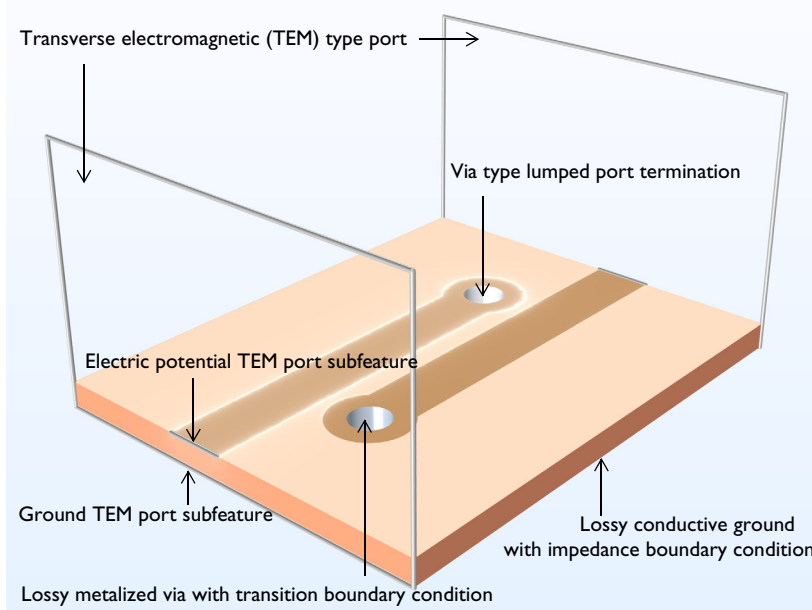

Figure 1: Microstrip line circuit board modeled with TEM ports and a via type lumped port. The top air domain is not included for visualization purposes.

Model Definition

The model describes two 50Ω microstrip lines adjacent to each other on a 60 mil substrate with the dielectric constant of $\epsilon_r = 3.38$. One microstrip line is terminated with a via type lumped port and the other line is finished with a metalized via hole. The interior surfaces of metallic parts, including the patterned line on the top of the substrate and a metalized via, are defined using a transition boundary condition to capture the loss from a finite conductivity. The ground plane is located on the exterior surface of the model domain and characterized by an impedance boundary condition that is also used for modeling lossy conductive boundaries.

A transverse electromagnetic (TEM) type port boundary condition is used on each side of the cuboid model domain touching the microstrip line and ground plane. The TEM type port is completed by adding electric potential and ground subfeatures. The edge of microstrip line top trace on the TEM port boundary is set to electric potential while the edge of ground plane on the TEM port boundary is set to ground. The material above the circuit board is air.

Results and Discussion

After simulation, the default plot is modified to plot the electric field norm on the top surface of the circuit board as shown in [Figure 2](#). It is observed that the input power to port 1 is partially coupled to the adjacent microstrip line connected to port 3.

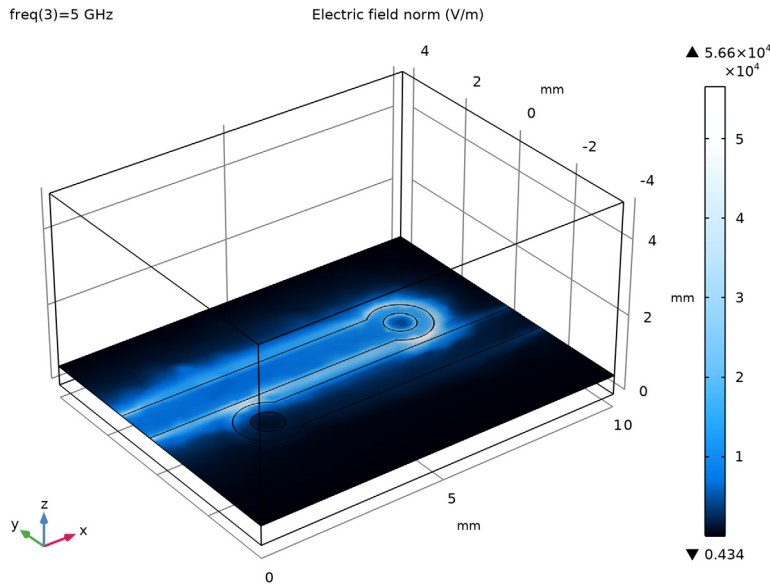

Figure 2: Electric field norm plot. A fraction of input power is coupled to the adjacent microstrip line.

[Figure 3](#) quantitatively shows the amount of coupling and crosstalk among ports. The computed S_{21} indicates that most of the input power is flown into the via-type

lumped port (port 2). The far-end crosstalk in this circuit, S_{31} , increases with the simulation frequency.

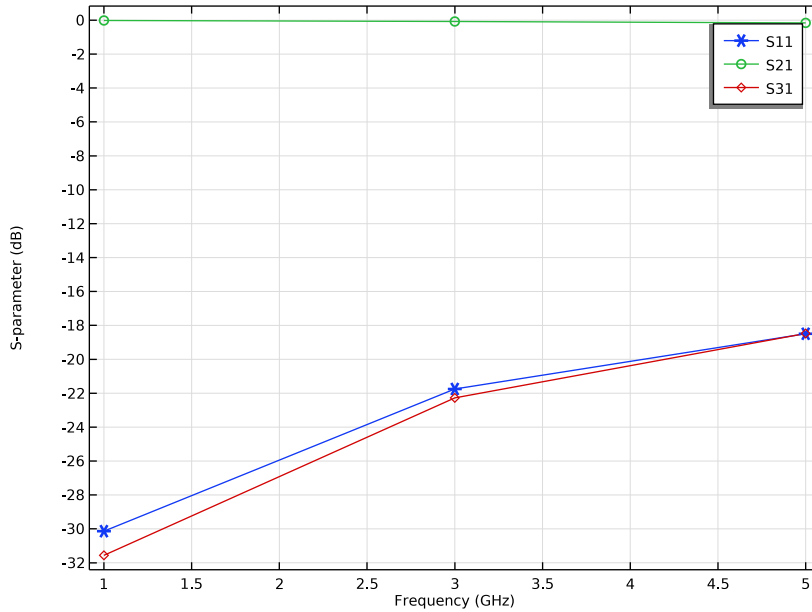



Figure 3: S-parameter plot describes impedance mismatching (S_{11}), insertion loss to the via port (S_{21}), and far-end crosstalk, FEXT (S_{31}).

Application Library path: RF_Module/Transmission_Lines_and_Waveguides/microstrip_line_tem_via

Modeling Instructions



From the **File** menu, choose **New**.

NEW

In the **New** window, click  **Model Wizard**.

MODEL WIZARD

1 In the **Model Wizard** window, click  **3D**.

- 2 In the **Select Physics** tree, select **Radio Frequency > Electromagnetic Waves, Frequency Domain (emw)**.
- 3 Click **Add**.
- 4 Click  **Study**.
- 5 In the **Select Study** tree, select **Preset Studies for Selected Physics Interfaces > TEM Boundary Mode Analysis**.
- 6 Click  **Done**.

GLOBAL DEFINITIONS

Parameters 1

- 1 In the **Model Builder** window, under **Global Definitions** click **Parameters 1**.
- 2 In the **Settings** window for **Parameters**, locate the **Parameters** section.
- 3 In the table, enter the following settings:

Name	Expression	Value	Description
tsub	20[mil]	5.08E-4 m	Substrate thickness

It is convenient to define parameters for frequently used values. Here, mil refers to the unit milliinch.

GEOMETRY 1

- 1 In the **Model Builder** window, under **Component 1 (comp1)** click **Geometry 1**.
- 2 In the **Settings** window for **Geometry**, locate the **Units** section.
- 3 From the **Length unit** list, choose **mm**.

Block 1 (blk1)

- 1 In the **Geometry** toolbar, click  **Block**.
- 2 In the **Settings** window for **Block**, locate the **Size and Shape** section.
- 3 In the **Width** text field, type 10.
- 4 In the **Depth** text field, type 8.
- 5 In the **Height** text field, type tsub*10.
- 6 Locate the **Position** section. In the **y** text field, type -4.
- 7 Click to expand the **Layers** section. In the table, enter the following settings:

Layer name	Thickness (mm)
Layer 1	tsub

Work Plane 1 (wp1)

1 In the **Geometry** toolbar, click  **Work Plane**.

Signal traces are patterned on this work plane.

2 In the **Settings** window for **Work Plane**, locate the **Plane Definition** section.

3 In the **z-coordinate** text field, type tsub.

Work Plane 1 (wp1) > Plane Geometry

In the **Model Builder** window, click **Plane Geometry**.

Work Plane 1 (wp1) > Rectangle 1 (r1)

1 In the **Work Plane** toolbar, click  **Rectangle**.

2 In the **Settings** window for **Rectangle**, locate the **Size and Shape** section.

3 In the **Width** text field, type 7.5.

4 In the **Height** text field, type 1.13.

5 Locate the **Position** section. In the **yw** text field, type -0.565+0.8.

Work Plane 1 (wp1) > Circle 1 (c1)

1 In the **Work Plane** toolbar, click  **Circle**.

2 In the **Settings** window for **Circle**, locate the **Size and Shape** section.

3 In the **Radius** text field, type 0.8.

4 Locate the **Position** section. In the **xw** text field, type 7.5.

5 In the **yw** text field, type 0.8.

Work Plane 1 (wp1) > Union 1 (uni1)

1 In the **Work Plane** toolbar, click  **Booleans and Partitions** and choose **Union**.

2 Click in the **Graphics** window and then press Ctrl+A to select both objects.

3 In the **Settings** window for **Union**, locate the **Union** section.

4 Clear the **Keep interior boundaries** checkbox.

5 Click the  **Wireframe Rendering** button in the **Graphics** toolbar. The wireframe rendering provides a better view of inside the box.

Cylinder 1 (cyl1)

1 In the **Geometry** toolbar, click  **Cylinder**.

2 In the **Settings** window for **Cylinder**, locate the **Size and Shape** section.

3 In the **Radius** text field, type 0.4.

4 In the **Height** text field, type tsub.

5 Locate the **Position** section. In the **x** text field, type 7.5.

6 In the **y** text field, type 0.8.

The side surfaces of the cylinder will be configured as Via type lumped port and metalized via hole, later.

Rotate 1 (rot1)

1 In the **Geometry** toolbar, click  **Transforms** and choose **Rotate**.

2 Select the objects **cyll** and **wpl** only.

3 In the **Settings** window for **Rotate**, locate the **Input** section.

4 Select the **Keep input objects** checkbox.

5 Locate the **Rotation** section. In the **Angle** text field, type 180.

6 Click  **Build All Objects**.

7 Locate the **Point on Axis of Rotation** section. In the **x** text field, type 5.

8 Click  **Build All Objects**.

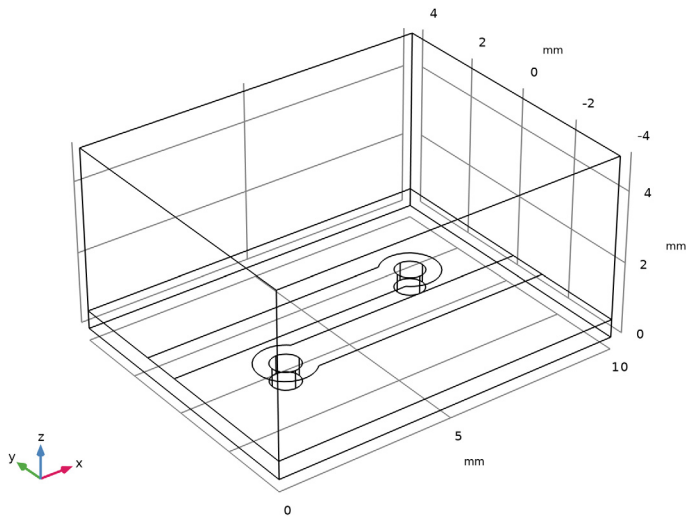

ELECTROMAGNETIC WAVES, FREQUENCY DOMAIN (EMW)

Wave Equation, Electric 2

1 In the **Physics** toolbar, click  **Domains** and choose **Wave Equation, Electric**.

2 Select Domain 1 only.

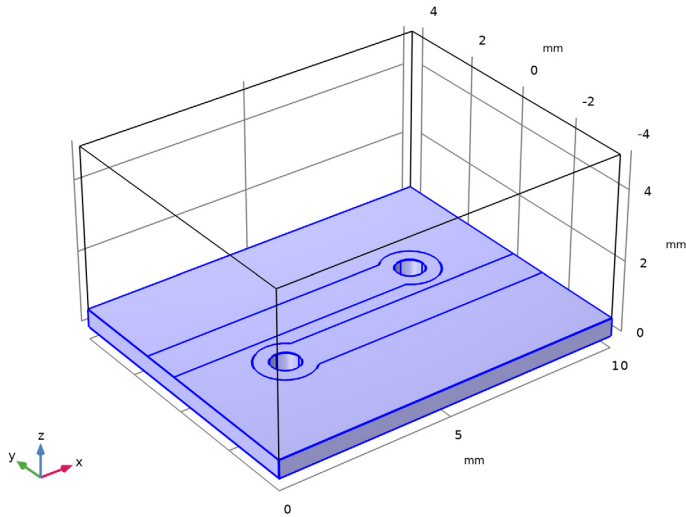

3 In the **Settings** window for **Wave Equation, Electric**, locate the **Electric Displacement Field** section.

4 From the **Electric displacement field model** list, choose **Loss tangent, dissipation factor**.

The material properties for the substrate, that will imported from the RF material library, are defined based on the dielectric constant and loss tangent. It is necessary to choose the right constitutive relation for the substrate domain.

Transition Boundary Condition 1

1 In the **Physics** toolbar, click  **Boundaries** and choose **Transition Boundary Condition**. Lossy conductive surfaces can be modeled using **Transition Boundary Condition** for interior boundaries.

2 Select Boundaries 8, 11–13, 16, and 17 only.

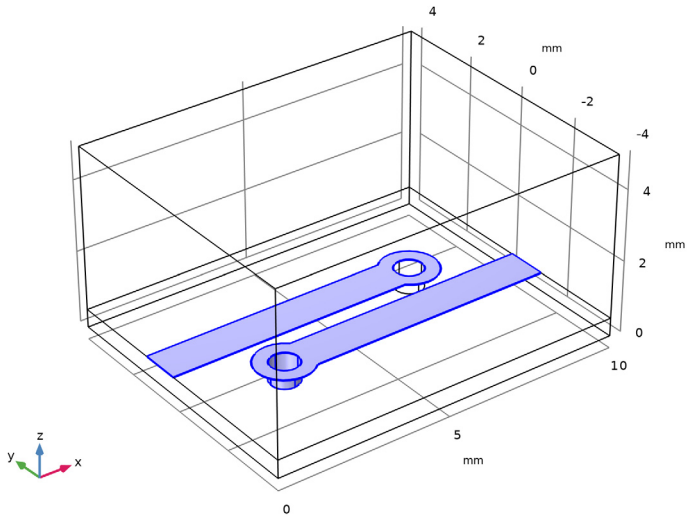

3 In the **Settings** window for **Transition Boundary Condition**, locate the **Transition Boundary Condition** section.

4 In the d text field, type $38[\mu\text{m}]$.

Impedance Boundary Condition 1

1 In the **Physics** toolbar, click  **Boundaries** and choose **Impedance Boundary Condition**. Lossy conductive surfaces can be modeled using **Impedance Boundary Condition** for exterior boundaries. This can also be looked as geometrically thick conductive volume.

2 Select Boundary 3 only.

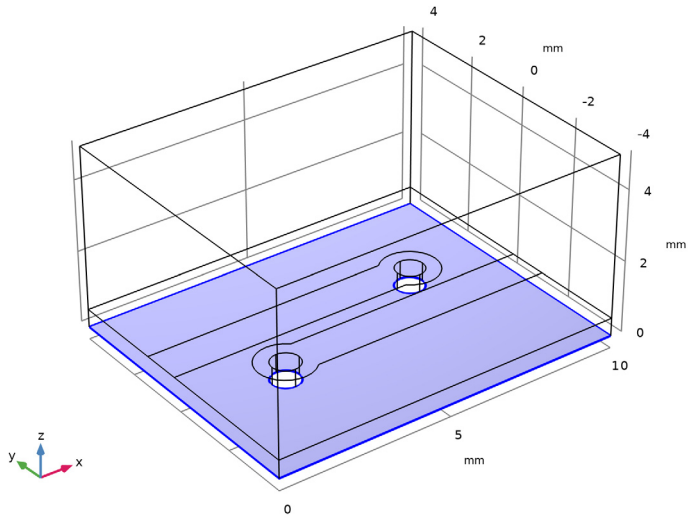

Port 1

1 In the **Physics** toolbar, click  **Boundaries** and choose **Port**.

2 Select Boundaries 1 and 4 only.

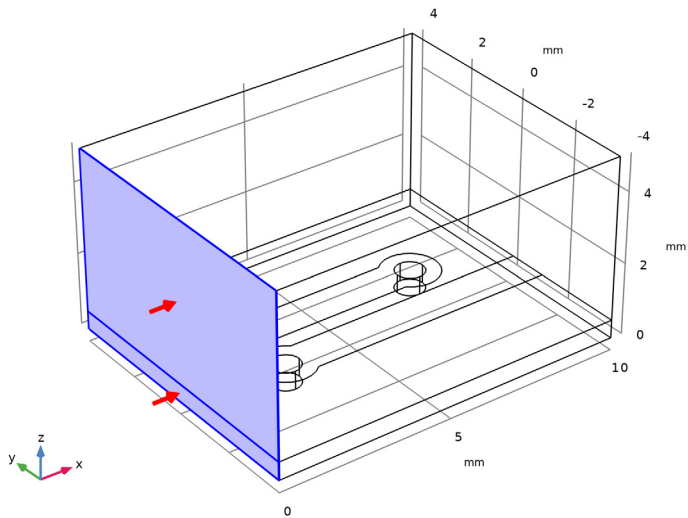

3 In the **Settings** window for **Port**, locate the **Port Properties** section.

4 From the **Type of port** list, choose **Transverse electromagnetic (TEM)**.

Transmission lines supporting the (quasi-) TEM mode can be analyzed with the **TEM** type port.

Ground /

1 In the **Physics** toolbar, click  **Attributes** and choose **Ground**.

The exterior edges of the port boundaries are set to ground by default.

Port /

In the **Model Builder** window, click **Port 1**.

Electric Potential /

1 In the **Physics** toolbar, click  **Attributes** and choose **Electric Potential**.

2 Select Edge 9 only.

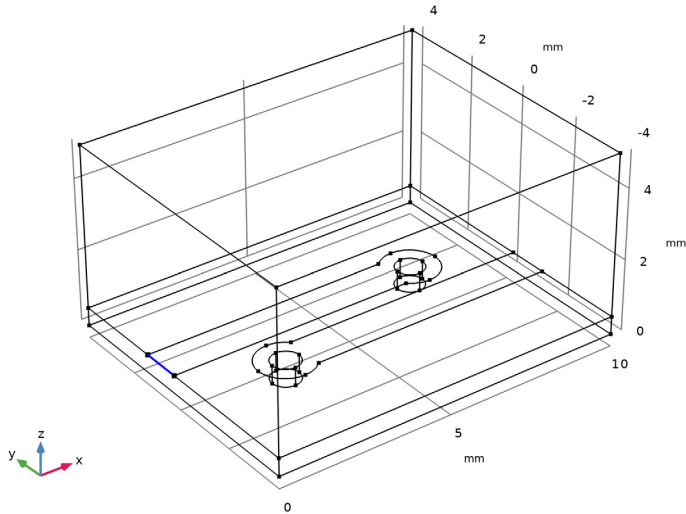

The electric potential edge is assigned on the signal trace.

Lumped Port /

1 In the **Physics** toolbar, click  **Boundaries** and choose **Lumped Port**.

2 Click the  **Select Box** button in the **Graphics** toolbar.

3 Select Boundaries 18, 19, 22, and 23 only.

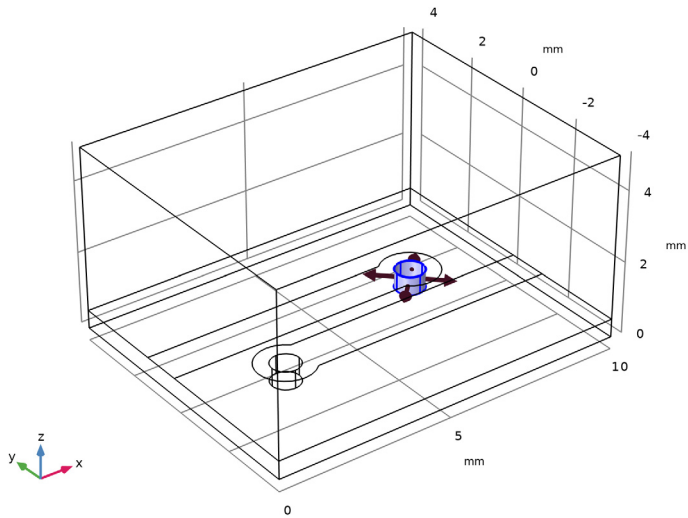

4 In the **Settings** window for **Lumped Port**, locate the **Lumped Port Properties** section.

5 From the **Type of lumped port** list, choose **Via**.

Port 2

1 In the **Physics** toolbar, click  **Boundaries** and choose **Port**.

2 Select Boundaries 24 and 25 only.

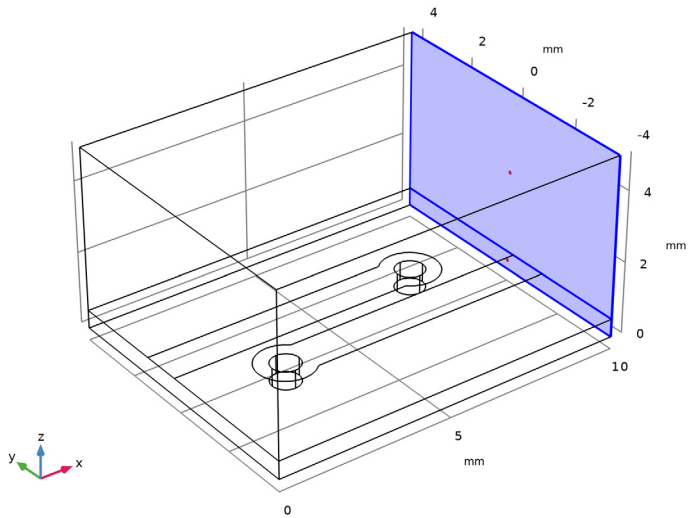

3 In the **Settings** window for **Port**, locate the **Port Properties** section.

4 From the **Type of port** list, choose **Transverse electromagnetic (TEM)**.

Ground 1

In the **Physics** toolbar, click  **Attributes** and choose **Ground**.

Port 2

In the **Model Builder** window, click **Port 2**.

Electric Potential 1

1 In the **Physics** toolbar, click  **Attributes** and choose **Electric Potential**.

2 Select Edge 57 only.

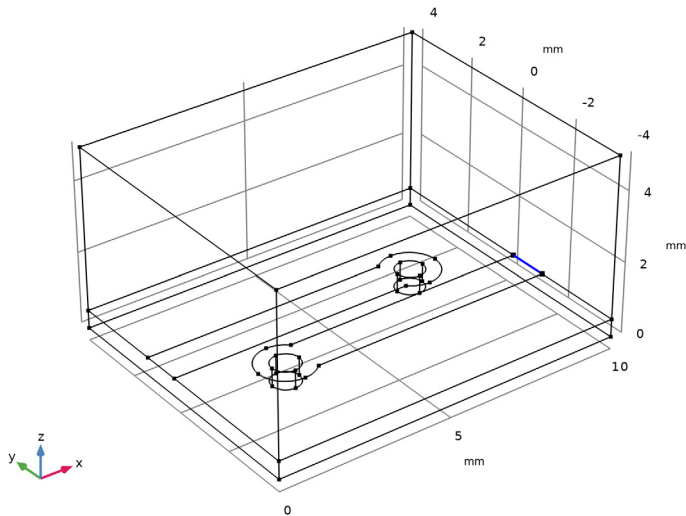

Now, make sure that Advanced Physics Options is enabled. Then, set the physics to use the constraint-based port formulation, that works best with TEM-type ports.

- 3 Click the  **Show More Options** button in the **Model Builder** toolbar.
- 4 In the **Show More Options** dialog, select **Physics > Advanced Physics Options** in the tree.
- 5 In the tree, select the checkbox for the node **Physics > Advanced Physics Options**.
- 6 Click **OK**.
- 7 In the **Model Builder** window, click **Electromagnetic Waves, Frequency Domain (emw)**.
- 8 In the **Settings** window for **Electromagnetic Waves, Frequency Domain**, click to expand the **Port Options** section.
- 9 From the **Port formulation** list, choose **Constraint-based**.

ADD MATERIAL

- 1 In the **Materials** toolbar, click  **Add Material** to open the **Add Material** window.
- 2 Go to the **Add Material** window.
- 3 In the tree, select **Built-in > Air**.
- 4 Click the **Add to Component** button in the window toolbar.
- 5 In the tree, select **Built-in > Copper**.
- 6 Click the **Add to Component** button in the window toolbar.

MATERIALS

Copper (mat2)

- 1 In the **Settings** window for **Material**, locate the **Geometric Entity Selection** section.
- 2 From the **Geometric entity level** list, choose **Boundary**.
- 3 Select Boundaries 3, 8, 11–14, 16, and 17 only.

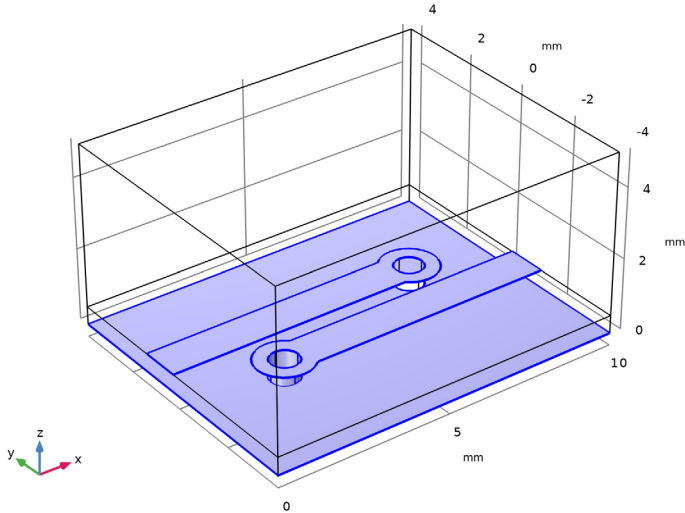

ADD MATERIAL

- 1 Go to the **Add Material** window.
- 2 In the tree, select **RF > Rogers Corporation > Rogers RO4000® Laminates > R04003C™ Laminates**.
- 3 Click the **Add to Component** button in the window toolbar.
- 4 In the **Materials** toolbar, click  **Add Material** to close the **Add Material** window.

MATERIALS

RO4003C™ Laminates (mat3)

Select Domain 1 only.

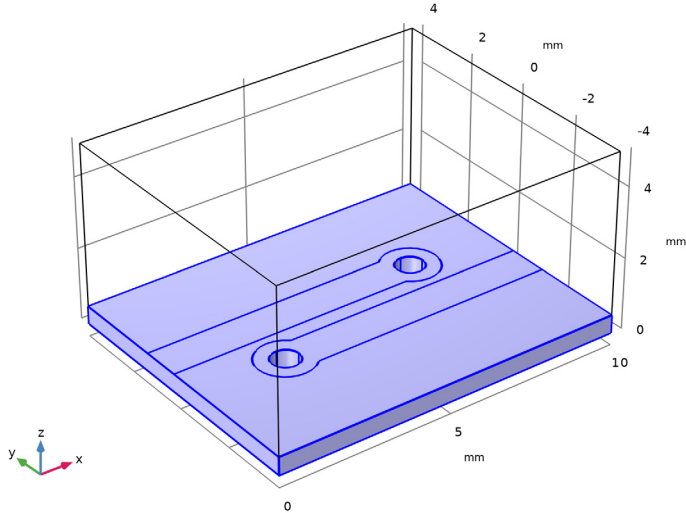

STUDY I

Step 2: Frequency Domain

- 1 In the **Model Builder** window, under **Study I** click **Step 2: Frequency Domain**.
- 2 In the **Settings** window for **Frequency Domain**, locate the **Study Settings** section.
- 3 In the **Frequencies** text field, type 1 3 5.

MESH I

In the **Model Builder** window, under **Component I (comp1)** right-click **Mesh I** and choose **Build All**.

DEFINITIONS

View I

Remove some boundaries from the view to inspect the mesh.

Hide for Physics I

- 1 In the **Model Builder** window, expand the **Component I (comp1)** > **Definitions** node.
- 2 Right-click **View I** and choose **Hide for Physics**.

- 3 In the **Settings** window for **Hide for Physics**, locate the **Geometric Entity Selection** section.
- 4 From the **Geometric entity level** list, choose **Boundary**.
- 5 Select Boundaries 5 and 7 only.

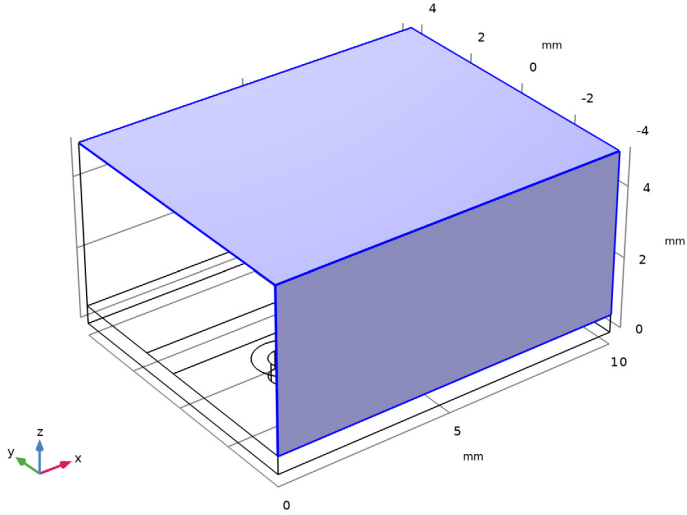

MESH 1

1 In the **Model Builder** window, under **Component 1 (comp1)** click **Mesh 1**.

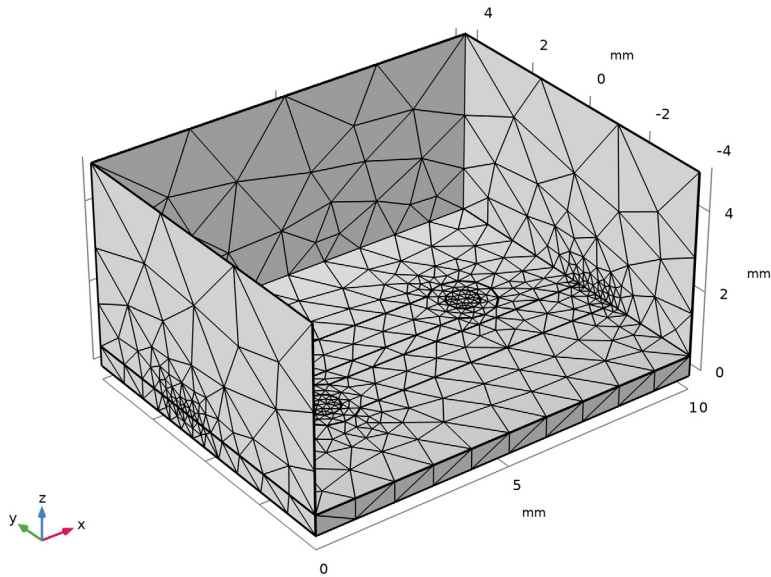

2 In the **Home** toolbar, click  **Compute**.

RESULTS

Multislice 1

1 In the **Model Builder** window, expand the **Results > Electric Field (emw)** node, then click **Multislice 1**.

2 In the **Settings** window for **Multislice**, locate the **Multiplane Data** section.

3 Find the **X-planes** subsection. In the **Planes** text field, type 0.

4 Find the **Y-planes** subsection. In the **Planes** text field, type 0.

5 Find the **Z-planes** subsection. From the **Entry method** list, choose **Coordinates**.

6 In the **Coordinates** text field, type t_{sub} .

7 Locate the **Coloring and Style** section. From the **Color table** list, choose **JupiterAuroraBorealis**.

Compare the reproduced plot to [Figure 2](#).

Global 1

- 1 In the **Model Builder** window, expand the **Results > S-Parameter (emw)** node, then click **Global 1**.
- 2 In the **Settings** window for **Global**, click to expand the **Coloring and Style** section.
- 3 Find the **Line markers** subsection. From the **Marker list**, choose **Cycle**.

The S-parameter plot is shown in [Figure 3](#). This describe the impedance mismatching in the input port and signal coupling to the adjacent microstrip line.

Smith Plot (emw)

In the **Model Builder** window, under **Results** click **Smith Plot (emw)**.

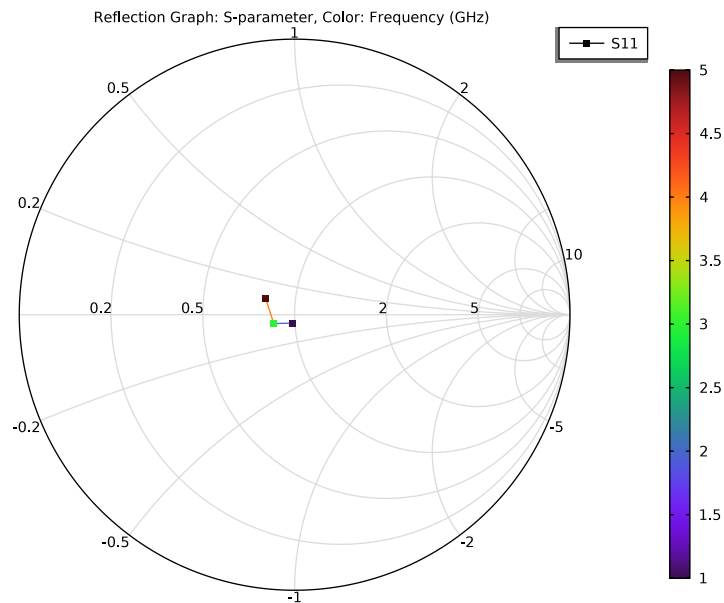

Electric Field, Logarithmic (emw)

In the **Model Builder** window, click **Electric Field, Logarithmic (emw)**.

freq(3)=5 GHz Surface: 1 (1) Surface: 1 (1) Surface: Electric field norm (V/m) Surface: Electric field norm (V/m)

