



Model created in COMSOL Multiphysics 6.4

Study of a Defective Microstrip Line via Frequency-to-Time FFT Analysis

Introduction

While transient analyses are useful for time domain reflectometry (TDR) to handle signal integrity (SI) problems, many RF and microwave examples are addressed using frequency domain simulations generating S-parameters. However, from the frequency domain data it is difficult to identify sources for this signal degradation.

This example simulates a microstrip line in frequency domain with a couple of line width discontinuities and performs frequency-to-time fast Fourier transform. The computed results help to identify the physical discontinuities and impedance mismatches on the transmission line, by analyzing the signal fluctuation in the time domain.

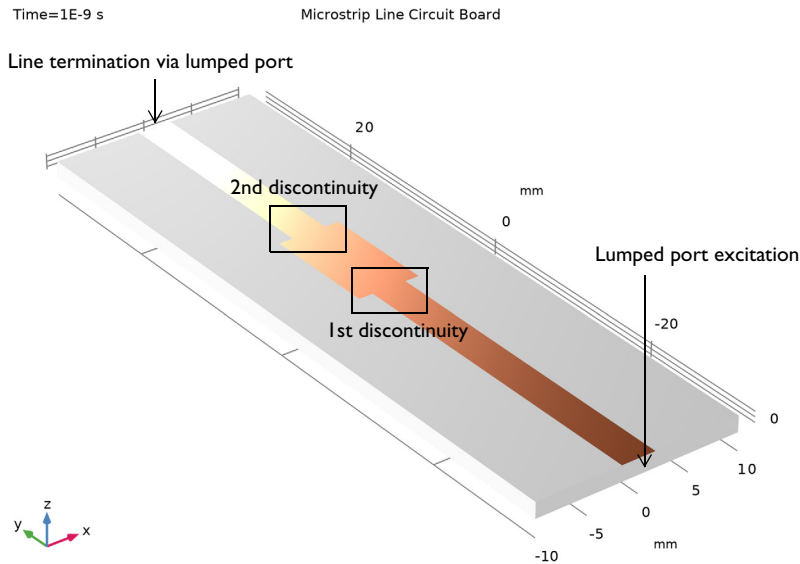

Figure 1: Microstrip line circuit board model using lumped ports. The surrounding air domain is not included for visualization purposes.

Model Definition

The model describes a 50Ω microstrip line on a 60 mil substrate with the dielectric constant of $\epsilon_r = 3.38$. A wider strip is placed in the middle of the microstrip line to represent a lower impedance line causing unwanted reflections. All metallic parts, including the patterned line on the top of the substrate and bottom ground plane, are set to perfect electric conductor (PEC) by ignoring the loss from a finite conductivity to simplify the modeling process. The small rectangular surfaces, bridging between each

microstrip end and the ground plane, are used to add lumped ports. The lumped ports excite the microstrip line and terminate it with 50Ω characteristic impedance. The material on top of the circuit board is air. The exterior surfaces of the air are finished by a scattering boundary condition that is an absorbing boundary to describe an open radiating space.

The study consists of two steps:

- Frequency Domain
- Frequency-to-Time FFT

The time domain results may vary with the input arguments in each study step.

TABLE 1: IMPACT OF THE STUDY STEP INPUT ARGUMENTS.

STUDY STEP	ARGUMENT	IMPACT ON TRANSFORMED TIME DOMAIN RESULT
Frequency Domain	Start frequency	Low frequency envelope noise
	Stop frequency	Resolution and high frequency ripple noise
	Frequency step	Alias period
Frequency-to-Time FFT	Stop time	Alias visibility

The frequency step, Δf , is set to make the period of alias in the time domain response greater than the round trip travel time from the excitation, lumped port 1, to the line termination, lumped port 2:

$$1/\Delta f = 1 \text{ ns} > 65 \text{ mm}/c_{\text{const}} \cdot \sqrt{3.38} \cdot 2 = 0.79723 \text{ ns}$$

where 65 mm is the circuit board length and c_{const} is a predefined COMSOL constant for the speed of light in vacuum.

While performing FFT, a Gaussian window function is used. This helps to suppress the noise coming from the limited range of the frequency sweep. Each study step uses “Store fields in output” that defines the selections where the computed results are stored. By choosing only the lumped port boundaries for Store fields in output settings, it is possible to reduce the size of the model file a lot.

Results and Discussion

Figure 2 shows the electric field norm on the lumped port boundaries in the time domain. The boundaries include the solutions transformed from the frequency-domain data. Since the FFT only transforms the dependent variable, the electric field E , to the time domain, it is only possible to use postprocessing variables directly related to E in the time domain. The frequency domain response is still accessible through Solution Store 1 dataset.

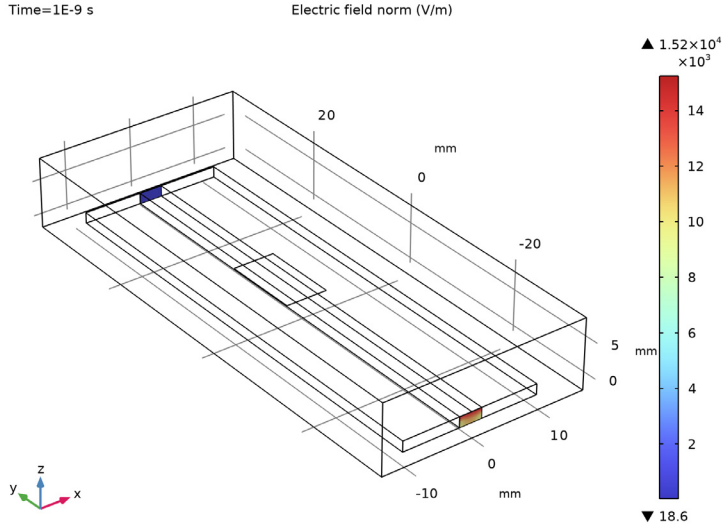

Figure 2: Time domain field on the lumped port boundaries.

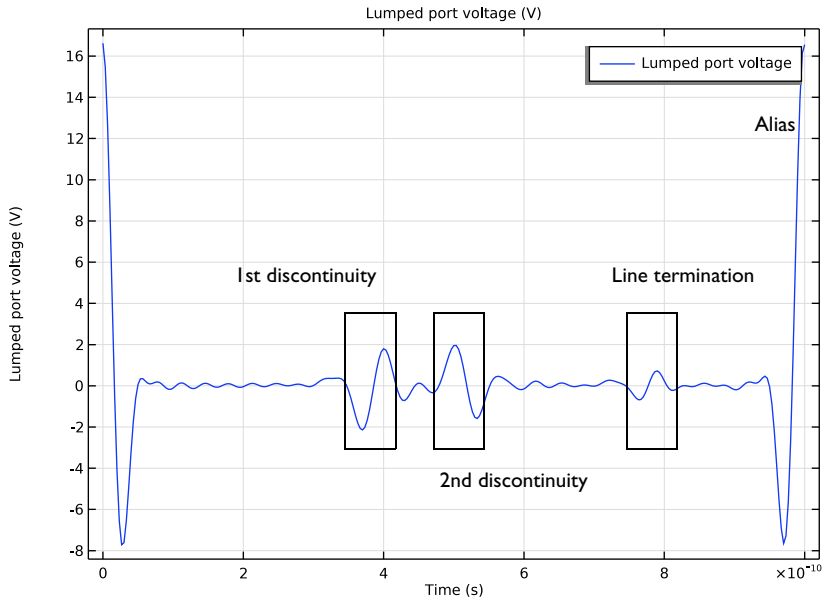

Figure 3: Time domain lumped port voltage. The overshoot and undershoot of the signal indicate the discontinuities of the microstrip line.

In [Figure 3](#), the time domain results of the voltage bandpass impulse response at lumped port 1 is plotted. The voltage fluctuation times correspond to the propagation times for the incident pulse to be reflected from the two line discontinuities—the defective parts of the 50 Ω microstrip line. The round trip travel time from lumped port 1 to each discontinuity is described in [Table 2](#) below. The estimated time agrees with the voltage fluctuation location in [Figure 3](#).

TABLE 2: ROUND TRIP TRAVEL TIME FROM LUMPED PORT 1 TO DISCONTINUITY.

DISCONTINUITY	EXPRESSION	TIME
Wider microstrip line start	$31.5 \text{ mm}/c_{\text{const}}*\sqrt{(3.38)}*2$	0.3864 ns
Wider microstrip line end	$42.5 \text{ mm}/c_{\text{const}}*\sqrt{(3.38)}*2$	0.5213 ns
Line termination	$65 \text{ mm}/c_{\text{const}}*\sqrt{(3.38)}*2$	0.7972 ns

The alias of the FFT is observed at 1 ns that is the inverse of the frequency step used in the frequency domain study step.

Notes About the COMSOL Implementation

The frequency-to-time fast Fourier transform (FFT) study step transforms the solution of dependent variables in frequency domain to time domain with a very small time step, ten samples per period, defined by the highest frequency in this model. Only the postprocessing variables that can be expressed with the dependent variables are valid for result analysis. Since the transformed solutions typically contain many time steps, it is recommended to use the **Store field in output** option to reduce the size of the model.

Application Library path: RF_Module/EMI_EMG_Applications/
microstrip_line_discontinuity

Modeling Instructions



From the **File** menu, choose **New**.

NEW

In the **New** window, click  **Model Wizard**.

MODEL WIZARD

1 In the **Model Wizard** window, click  **3D**.

- 2 In the **Select Physics** tree, select **Radio Frequency > Electromagnetic Waves, Frequency Domain (emw)**.
- 3 Click **Add**.
- 4 Click  **Study**.
- 5 In the **Select Study** tree, select **General Studies > Frequency Domain**.
- 6 Click  **Done**.

GLOBAL DEFINITIONS

Parameters 1

- 1 In the **Model Builder** window, under **Global Definitions** click **Parameters 1**.
- 2 In the **Settings** window for **Parameters**, locate the **Parameters** section.
- 3 In the table, enter the following settings:

Name	Expression	Value	Description
f0	15[GHz]	1.5E10 Hz	Center frequency
df	f0/15	1E9 Hz	Frequency resolution

STUDY 1

Step 1: Frequency Domain

Define the study frequency ahead of performing any frequency-dependent operation such as building mesh. The physics-controlled mesh uses the highest frequency value in the specified range.

- 1 In the **Model Builder** window, under **Study 1** click **Step 1: Frequency Domain**.
- 2 In the **Settings** window for **Frequency Domain**, locate the **Study Settings** section.
- 3 In the **Frequencies** text field, type range(0.01[GHz],df,2*f0).

GEOMETRY 1

- 1 In the **Model Builder** window, under **Component 1 (comp1)** click **Geometry 1**.
- 2 In the **Settings** window for **Geometry**, locate the **Units** section.
- 3 From the **Length unit** list, choose **mm**.

Block 1 (blk1)



- 1 In the **Geometry** toolbar, click  **Block**.
- 2 In the **Settings** window for **Block**, locate the **Size and Shape** section.
- 3 In the **Width** text field, type 20.

- 4 In the **Depth** text field, type 65.
- 5 In the **Height** text field, type 1.524.
- 6 Locate the **Position** section. From the **Base** list, choose **Center**.
Create a block for the microstrip line trace and two lumped port boundaries.

Block 2 (blk2)

- 1 In the **Geometry** toolbar, click  **Block**.
- 2 In the **Settings** window for **Block**, locate the **Size and Shape** section.
- 3 In the **Width** text field, type 3.3.
- 4 In the **Depth** text field, type 65.
- 5 In the **Height** text field, type 1.524.
- 6 Locate the **Position** section. From the **Base** list, choose **Center**.

Block 3 (blk3)

- 1 In the **Geometry** toolbar, click  **Block**.
- 2 In the **Settings** window for **Block**, locate the **Size and Shape** section.
- 3 In the **Width** text field, type 30.
- 4 In the **Depth** text field, type 70.
- 5 In the **Height** text field, type 10.
- 6 Locate the **Position** section. In the **z** text field, type $(10 - 1.524) / 2$.
- 7 From the **Base** list, choose **Center**.
- 8 Click  **Build Selected**.
- 9 Click the  **Wireframe Rendering** button in the **Graphics** toolbar.

Work Plane 1 (wpl)

- 1 In the **Geometry** toolbar, click  **Work Plane**.
- 2 In the **Settings** window for **Work Plane**, locate the **Plane Definition** section.
- 3 From the **Plane type** list, choose **Face parallel**.

4 On the object **blk1**, select Boundary 4 only.

It might be easier to select the correct boundary by using the **Selection List** window. To open this window, in the **Home** toolbar click **Windows** and choose **Selection List**. (If you are running the cross-platform desktop, you find **Windows** in the main menu.)

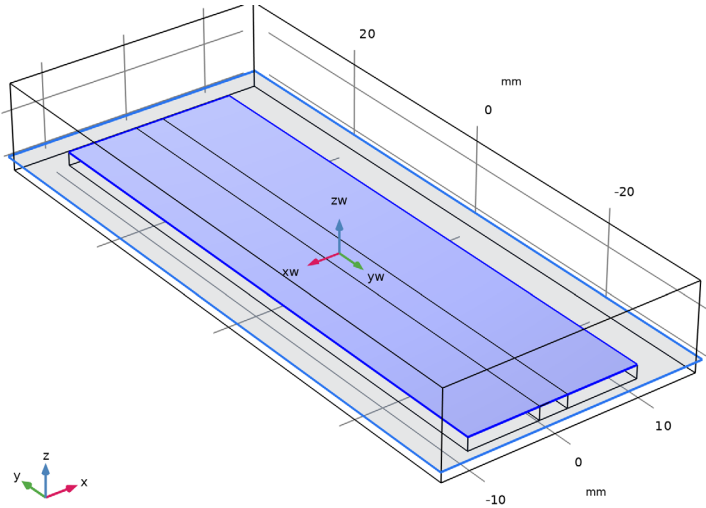

Work Plane 1 (wp1) > Plane Geometry

In the **Model Builder** window, click **Plane Geometry**.

Work Plane 1 (wp1) > Rectangle 1 (r1)

1 In the **Work Plane** toolbar, click  **Rectangle**.

2 In the **Settings** window for **Rectangle**, locate the **Size and Shape** section.

3 In the **Width** text field, type 6.

4 In the **Height** text field, type 11.

5 Locate the **Position** section. In the **xw** text field, type -3.

6 In the **yw** text field, type -10.

7 In the **Model Builder** window, right-click **Geometry 1** and choose **Build All**.

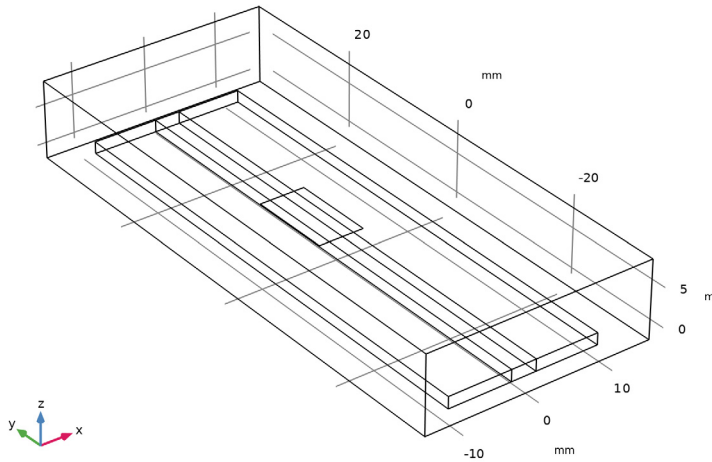

ELECTROMAGNETIC WAVES, FREQUENCY DOMAIN (EMW)

Lumped Port 1

- 1 In the **Physics** toolbar, click  **Boundaries** and choose **Lumped Port**.
- 2 Select Boundary 13 only.

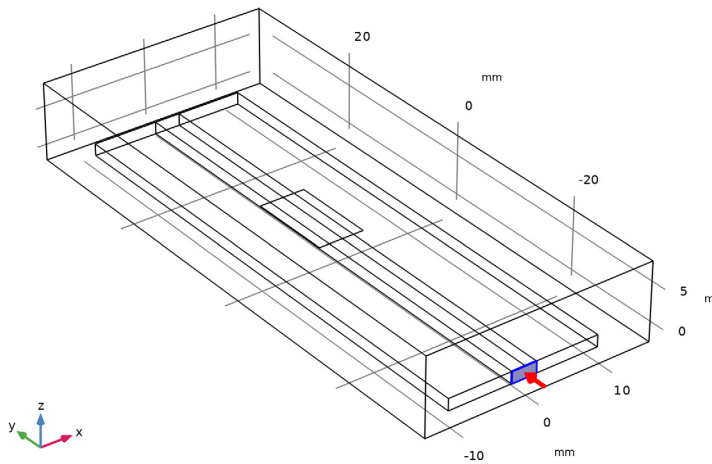

3 In the **Settings** window for **Lumped Port**, locate the **Boundary Selection** section.

4 Click  **Create Selection**.

5 In the **Create Selection** dialog, click **OK**.

Lumped Port 2

1 In the **Physics** toolbar, click  **Boundaries** and choose **Lumped Port**.

2 Select Boundary 18 only.

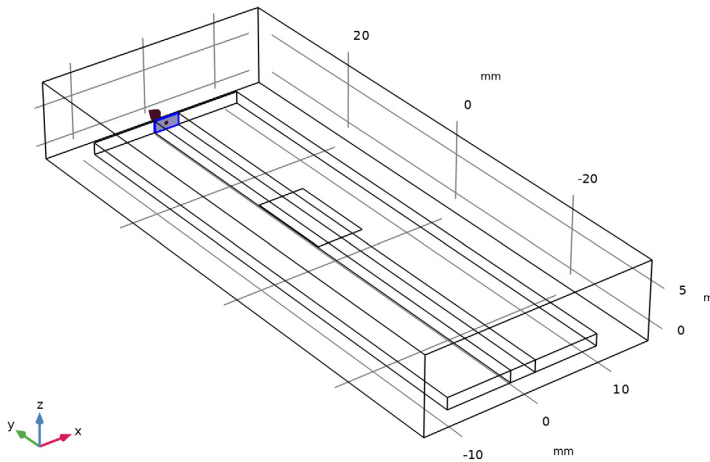

3 In the **Settings** window for **Lumped Port**, locate the **Boundary Selection** section.

4 Click  **Create Selection**.

The added selection will be used to define where to store the results. The model evaluates only the lumped port voltage in time and frequency domain.

5 In the **Create Selection** dialog, click **OK**.

Perfect Electric Conductor 2

1 In the **Physics** toolbar, click  **Boundaries** and choose **Perfect Electric Conductor**.

2 Select Boundaries 11, 15–17, and 23 only.

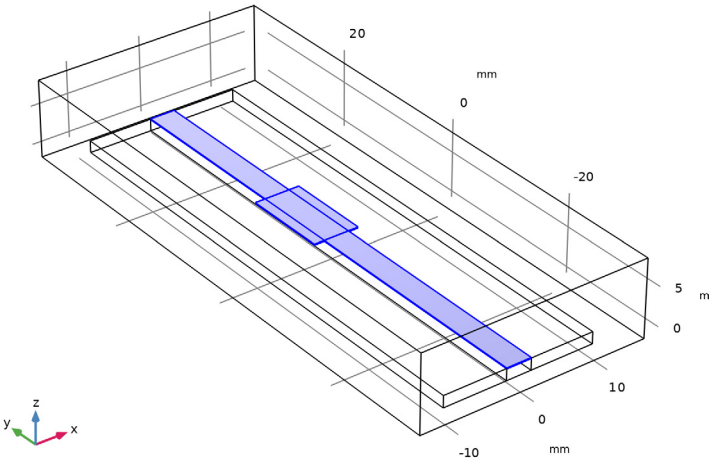

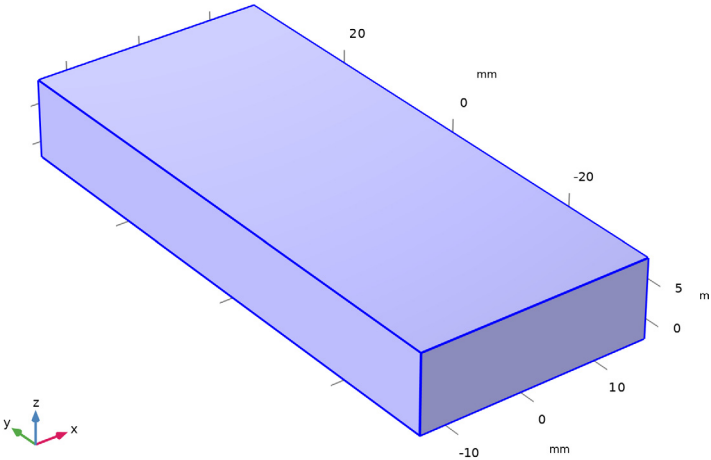

Scattering Boundary Condition 1

- 1 In the **Physics** toolbar, click  **Boundaries** and choose **Scattering Boundary Condition**.
- 2 Select Boundaries 1, 2, 4, 5, and 26 only.



ADD MATERIAL

- 1 In the **Materials** toolbar, click  **Add Material** to open the **Add Material** window.
- 2 Go to the **Add Material** window.
- 3 In the tree, select **Built-in > Air**.
- 4 Click the **Add to Component** button in the window toolbar.
- 5 In the **Materials** toolbar, click  **Add Material** to close the **Add Material** window.

MATERIALS

Material 2 (mat2)

- 1 In the **Model Builder** window, under **Component 1 (comp1)** right-click **Materials** and choose **Blank Material**.
- 2 Select Domains 2–4 only.

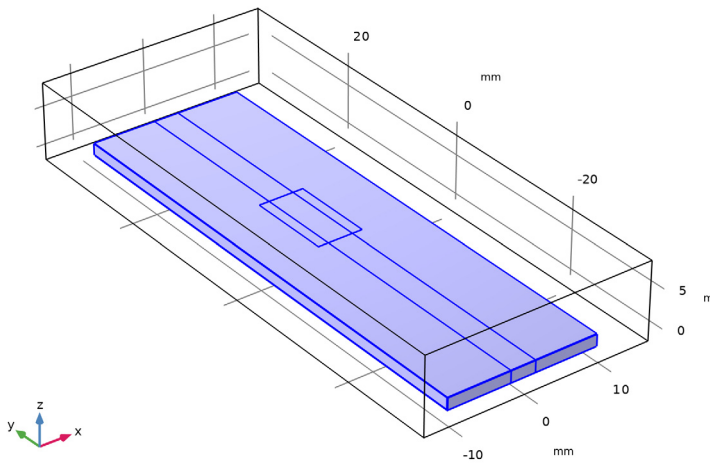

- 3 In the **Settings** window for **Material**, locate the **Material Contents** section.

4 In the table, enter the following settings:

Property	Variable	Value	Unit	Property group
Relative permittivity	epsilon _{nr_iso} ; epsilon _{nrii} = epsilon _{nr_iso} , epsilon _{nrij} = 0	3.38		Basic
Relative permeability	mu _{r_iso} ; mu _{rii} = mu _{r_iso} , mu _{rij} = 0	1		Basic
Electric conductivity	sigma _{iso} ; sigma _{ii} = sigma _{iso} , sigma _{ij} = 0	0	S/m	Basic

MESH 1

- 1 In the **Model Builder** window, under **Component 1 (comp1)** right-click **Mesh 1** and choose **Build All**.
- 2 Click the  **Click and Hide** button in the **Graphics** toolbar.
- 3 Select Boundary 4 only.
- 4 Select Boundary 1 only.

5 Select Boundary 2 only.

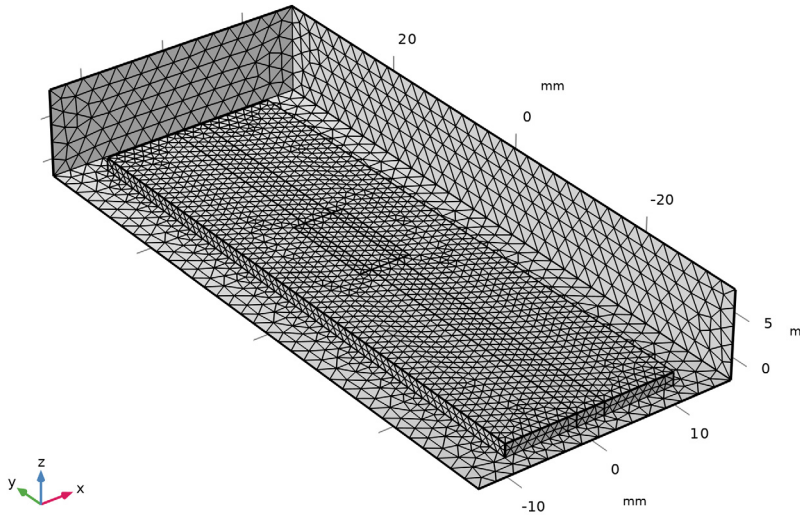

STUDY 1

Step 1: Frequency Domain

The period of a ripple noise and alias after FFT are defined by the inverse of the maximum frequency and frequency step, respectively.

- 1 In the **Model Builder** window, under **Study 1** click **Step 1: Frequency Domain**.
- 2 In the **Settings** window for **Frequency Domain**, click to expand the **Store in Output** section.
- 3 In the table, enter the following settings:

Interface	Output
Electromagnetic Waves, Frequency Domain (emw)	Selection

- 4 Click to select the first row in the table.
- 5 Under **Selections**, click **+ Add**.
- 6 In the **Add** dialog, in the **Selections** list, choose **Explicit 1** and **Explicit 2**.

7 Click **OK**.

By choosing only the port boundaries for **Store in Output** settings, it is possible to reduce the size of a model file a lot. The lumped port boundaries are included for the voltage evaluation.

Step 2: Frequency to Time FFT

1 In the **Study** toolbar, click  **More Study Steps** and choose **Time Dependent** > **Frequency to Time FFT**.

2 In the **Settings** window for **Frequency to Time FFT**, locate the **Study Settings** section.

3 In the **Times** text field, type range $(0, 1/f_0/20, 1/df)$.

4 From the **Scaling** list, choose **Discrete Fourier transform**.

Use Window function to suppress a high frequency ripple noise.

5 Select the **Use window function** checkbox.

6 From the **Window function** list, choose **Gaussian**.

7 In the **Window center** text field, type f_0 .

8 In the **Standard deviation** text field, type $f_0/4$.

9 Click to expand the **Store in Output** section. In the table, enter the following settings:

Interface	Output
Electromagnetic Waves, Frequency Domain (emw)	Selection

10 Click to select the first row in the table.

11 Under **Selections**, click  **Add**.

12 In the **Add** dialog, in the **Selections** list, choose **Explicit 1** and **Explicit 2**.

13 Click **OK**.

14 In the **Study** toolbar, click  **Compute**.

RESULTS

Multislice 1

1 In the **Model Builder** window, expand the **Electric Field (emw)** node.

2 Right-click **Multislice 1** and choose **Delete**.

Surface 1

Right-click **Electric Field (emw)** and choose **Surface**.

Selection 1

- 1 In the **Model Builder** window, right-click **Surface 1** and choose **Selection**.
- 2 Select Boundaries 13 and 18 only.
- 3 In the **Electric Field (emw)** toolbar, click  **Plot**.

Time=1E-9 s

Electric field norm (V/m)

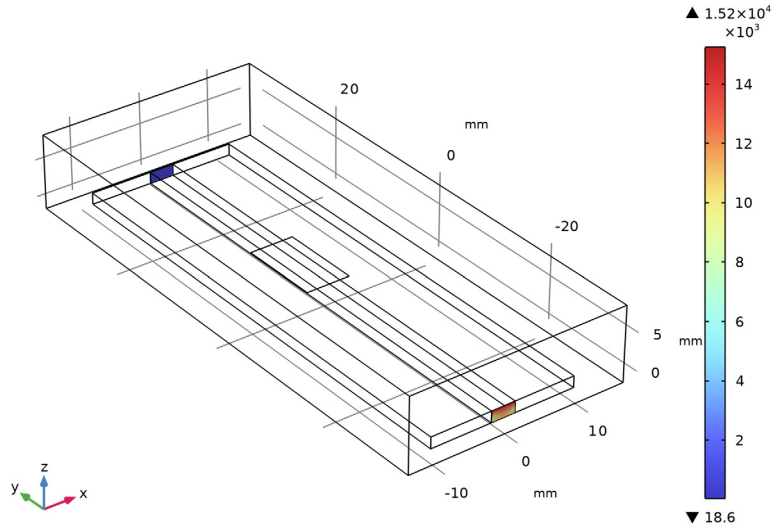

The results only on the lumped port boundaries are evaluated.

ID Plot Group 4

In the **Results** toolbar, click  **ID Plot Group**.

Global 1

- 1 Right-click **ID Plot Group 4** and choose **Global**.
- 2 In the **Settings** window for **Global**, locate the **y-Axis Data** section.
- 3 In the table, enter the following settings:

Expression	Unit	Description
emw.Vport_1	V	Lumped port voltage

- 4 In the **ID Plot Group 4** toolbar, click  **Plot**.

Compare the reproduced plot with [Figure 2](#).

A simple microstrip line circuit board can be visualized for presentation purposes without using the computed results.

Circuit board

- 1 In the **Results** toolbar, click  **3D Plot Group**.
- 2 In the **Settings** window for **3D Plot Group**, type **Circuit board** in the **Label** text field.
- 3 Click to expand the **Title** section. From the **Title type** list, choose **Manual**.
- 4 In the **Title** text area, type **Microstrip Line Circuit Board**.

Surface 1

- 1 Right-click **Circuit board** and choose **Surface**.
- 2 In the **Settings** window for **Surface**, locate the **Expression** section.
- 3 In the **Expression** text field, type 1.

Material Appearance 1

- 1 Right-click **Surface 1** and choose **Material Appearance**.
- 2 In the **Settings** window for **Material Appearance**, locate the **Appearance** section.
- 3 From the **Appearance** list, choose **Custom**.
- 4 From the **Material type** list, choose **Rose gold**.

Selection 1

- 1 In the **Model Builder** window, right-click **Surface 1** and choose **Selection**.
- 2 Select Boundaries 11, 15–17, and 23 only.

Surface 2

- 1 In the **Model Builder** window, right-click **Circuit board** and choose **Surface**.
- 2 In the **Settings** window for **Surface**, locate the **Expression** section.
- 3 In the **Expression** text field, type 1.

Material Appearance 1

- 1 Right-click **Surface 2** and choose **Material Appearance**.
- 2 In the **Settings** window for **Material Appearance**, locate the **Appearance** section.
- 3 From the **Appearance** list, choose **Custom**.

Selection 1

- 1 In the **Model Builder** window, right-click **Surface 2** and choose **Selection**.

2 Select Boundaries 6–10, 13, 14, 18, 20–22, 24, and 25 only.

3 In the **Circuit board** toolbar, click  **Plot**.

Circuit board

1 In the **Model Builder** window, under **Results** click **Circuit board**.

2 In the **Settings** window for **3D Plot Group**, locate the **Plot Settings** section.

3 Clear the **Plot dataset edges** checkbox.

4 In the **Circuit board** toolbar, click  **Plot**.

Time=1E-9 s

Microstrip Line Circuit Board

