



Model created in COMSOL Multiphysics 6.4

Simulation of an Electromagnetic Sounding Method for Oil Prospecting

Introduction

The marine controlled source electromagnetics method (CSEM) for oil prospecting has emerged as a promising technique during recent years. This example demonstrates one variant of it. It uses a mobile horizontal 1 Hz electric dipole antenna that is towed 150 m above the sea floor. An array of sea floor receivers measure the electric field at various distances away from the antenna. When measuring at sufficiently large distance, some of the transmitted energy is reflected/guided by the resistive reservoir and results in a higher received signal than if no reservoir were present.

Model Definition

The computational domain is a sphere of 5 km radius. The top region of this sphere represents air. At such a low frequency as 1 Hz, some numerical stabilization is required in this domain so an artificial conductivity of 0.001 S/m is specified. A 100 m deep ocean water domain with a conductivity of 3 S/m and a relative permittivity of 80 is specified above the midplane of the sphere. Below the midplane, a conductivity of 1.5 S/m and a relative permittivity of 30 is specified for the rock. Embedded in the rock at an average depth of 250 m, there is a block-shaped, 100 m deep and 4 km-by-1 km wide hydrocarbon reservoir. The conductivity of the hydrocarbon layer is 0.01 S/m and the permittivity is 4. The transmitter is modeled as a short 10 kA amplitude AC line current segment 150 m above the midplane. At the external spherical boundaries, a scattering type boundary condition absorbs outgoing spherical waves. The following equation is solved for the electric field vector \mathbf{E} inside the computational domain:

$$\nabla \times (\mu_r^{-1} \nabla \times \mathbf{E}) - k_0^2 \left(\epsilon_r - \frac{j\sigma}{\omega \epsilon_0} \right) \mathbf{E} = 0$$

where μ_r denotes the relative permeability, j the imaginary unit, σ the conductivity, ω the angular frequency, ϵ_r the relative permittivity, and ϵ_0 the permittivity of free space.

Results and Discussion

The first figure below shows a slice plot of the electric field magnitude on a dB scale where the guiding effect of the hydrocarbon layer is clearly visible.

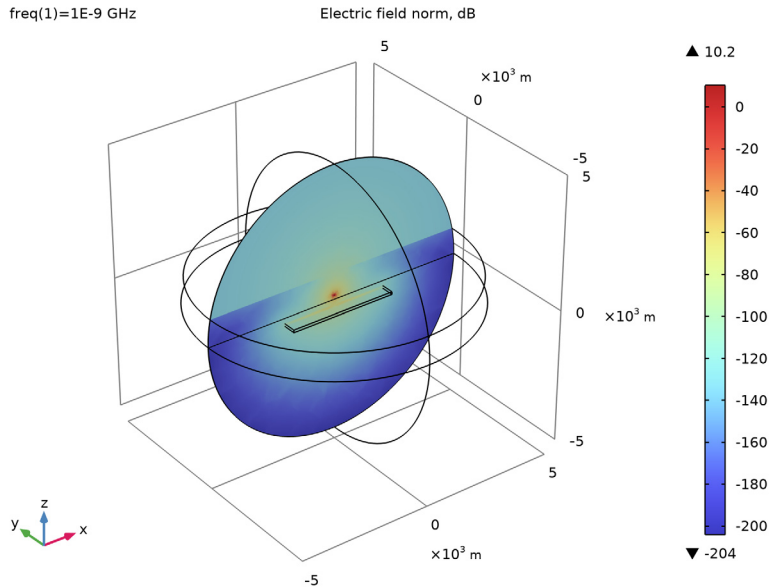

Figure 1: The electric field magnitude is plotted in a slice containing the antenna (red spot). The guiding effect of the hydrocarbon layer is clearly visible.

The effect is shown quantitatively in the next plot, where a comparison of the electric field magnitude on the sea floor is plotted as a function of distance for simulations with and without a hydrocarbon layer. The maximum is obtained right under the antenna where there is little difference between the two cases. When you move away from the antenna, there is a notably higher signal strength when the hydrocarbon layer is present.

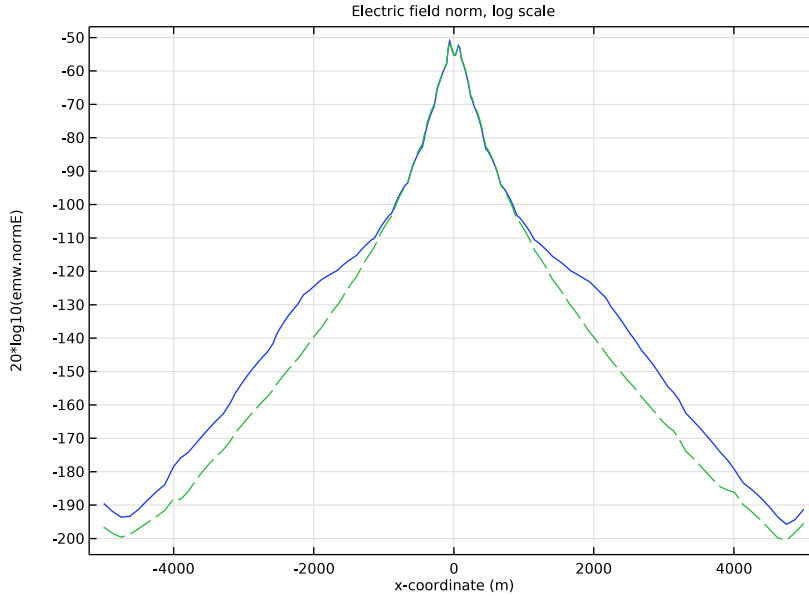

Figure 2: Electric field magnitude on the sea floor as a function of distance. The dashed line represents the case without a hydrocarbon layer.

Notes about the COMSOL Implementation

This example uses the 3D Electromagnetic Waves formulation available in the RF Module although the wavelength is much larger than the computational domain. You could also create this example using a quasi-static formulation in the AC/DC Module.

Application Library path: RF_Module/Scattering_and_RCS/marine_csem



Modeling Instructions

From the **File** menu, choose **New**.

NEW

In the **New** window, click  **Model Wizard**.

MODEL WIZARD

- 1 In the **Model Wizard** window, click  **3D**.
- 2 In the **Select Physics** tree, select **Radio Frequency > Electromagnetic Waves, Frequency Domain (emw)**.
- 3 Click **Add**.
- 4 Click  **Study**.
- 5 In the **Select Study** tree, select **General Studies > Frequency Domain**.
- 6 Click  **Done**.

GEOMETRY I

Sphere 1 (sph1)

- 1 In the **Geometry** toolbar, click  **Sphere**.
- 2 In the **Settings** window for **Sphere**, locate the **Size** section.
- 3 In the **Radius** text field, type 5e3.

Cylinder 1 (cyl1)

- 1 In the **Geometry** toolbar, click  **Cylinder**.
- 2 In the **Settings** window for **Cylinder**, locate the **Size and Shape** section.
- 3 In the **Radius** text field, type 6e3.
- 4 In the **Height** text field, type 1e3.

Intersection 1 (int1)

- 1 In the **Geometry** toolbar, click  **Booleans and Partitions** and choose **Intersection**.
- 2 Click in the **Graphics** window and then press Ctrl+A to select both objects.

Sphere 2 (sph2)

- 1 In the **Geometry** toolbar, click  **Sphere**.
- 2 In the **Settings** window for **Sphere**, locate the **Size** section.
- 3 In the **Radius** text field, type 5e3.

Block 1 (blk1)



- 1 In the **Geometry** toolbar, click  **Block**.
- 2 In the **Settings** window for **Block**, locate the **Size and Shape** section.
- 3 In the **Width** text field, type 4e3.
- 4 In the **Depth** text field, type 1e3.
- 5 In the **Height** text field, type 100.

- 6 Locate the **Position** section. From the **Base** list, choose **Center**.
- 7 In the **z** text field, type -250.

Line Segment 1 (ls1)

- 1 In the **Geometry** toolbar, click  **More Primitives** and choose **Line Segment**.
- 2 In the **Settings** window for **Line Segment**, locate the **Starting Point** section.
- 3 From the **Specify** list, choose **Coordinates**.
- 4 Locate the **Endpoint** section. From the **Specify** list, choose **Coordinates**.
- 5 Locate the **Starting Point** section. In the **x** text field, type -10 and **z** to 150.
- 6 Locate the **Endpoint** section. In the **x** text field, type 10 and **z** to 150.

Line Segment 2 (ls2)

- 1 In the **Geometry** toolbar, click  **More Primitives** and choose **Line Segment**.
- 2 In the **Settings** window for **Line Segment**, locate the **Starting Point** section.
- 3 From the **Specify** list, choose **Coordinates**.
- 4 Locate the **Endpoint** section. From the **Specify** list, choose **Coordinates**.
- 5 Locate the **Starting Point** section. In the **x** text field, type -5e3.
- 6 Locate the **Endpoint** section. In the **x** text field, type 5e3.
- 7 Click  **Build All Objects**.

8 Click the  **Wireframe Rendering** button in the **Graphics** toolbar.

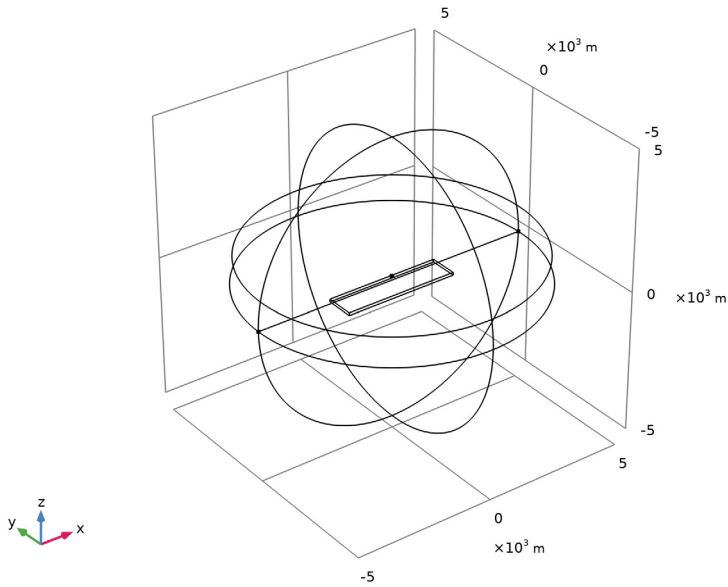

MATERIALS

Sea Water

- 1 In the **Model Builder** window, under **Component 1 (comp1)** right-click **Materials** and choose **Blank Material**.
- 2 In the **Settings** window for **Material**, type *Sea Water* in the **Label** text field.
- 3 Select Domain 1 only.
- 4 Locate the **Material Contents** section. In the table, enter the following settings:

Property	Variable	Value	Unit	Property group
Relative permittivity	epsilon _{nr_} iso ; epsilon _{nr} ij = epsilon _{nr_} iso, epsilon _{nr} ij = 0	80	1	Basic

Property	Variable	Value	Unit	Property group
Relative permeability	mur_iso ; murii = mur_iso, murij = 0	1		Basic
Electric conductivity	sigma_iso ; sigmai = sigma_iso, sigmaj = 0	3	S/m	Basic

Rock

- 1 Right-click **Materials** and choose **Blank Material**.
- 2 In the **Settings** window for **Material**, type Rock in the **Label** text field.
- 3 Select Domains 2 and 4 only.
- 4 Locate the **Material Contents** section. In the table, enter the following settings:

Property	Variable	Value	Unit	Property group
Relative permittivity	epsilon_r_iso ; epsilon_rii = epsilon_r_iso, epsilon_rij = 0	30		Basic
Relative permeability	mur_iso ; murii = mur_iso, murij = 0	1		Basic
Electric conductivity	sigma_iso ; sigmai = sigma_iso, sigmaj = 0	1.5	S/m	Basic

Oil

- 1 Right-click **Materials** and choose **Blank Material**.
- 2 In the **Settings** window for **Material**, type Oil in the **Label** text field.
- 3 Select Domain 4 only.

Note that this selection partly overrides the geometric scope setting that you just defined for rock. This allows you to later conveniently run the model for the case where there is no hydrocarbon reserve by simply disabling the Oil node.

4 Locate the **Material Contents** section. In the table, enter the following settings:

Property	Variable	Value	Unit	Property group
Relative permittivity	epsilon _{r_iso} ; epsilon _{r_ii} = epsilon _{r_iso} , epsilon _{r_ij} = 0	4		Basic
Relative permeability	mu _{r_iso} ; mu _{r_ii} = mu _{r_iso} , mu _{r_ij} = 0	1		Basic
Electric conductivity	sigma _{iso} ; sigma _{ii} = sigma _{iso} , sigma _{ij} = 0	0.01	S/m	Basic

Air

1 Right-click **Materials** and choose **Blank Material**.

2 In the **Settings** window for **Material**, type Air in the **Label** text field.

3 Select Domain 3 only.

4 Locate the **Material Contents** section. In the table, enter the following settings:

Property	Variable	Value	Unit	Property group
Relative permittivity	epsilon _{r_iso} ; epsilon _{r_ii} = epsilon _{r_iso} , epsilon _{r_ij} = 0	1		Basic
Relative permeability	mu _{r_iso} ; mu _{r_ii} = mu _{r_iso} , mu _{r_ij} = 0	1		Basic
Electric conductivity	sigma _{iso} ; sigma _{ii} = sigma _{iso} , sigma _{ij} = 0	0.001	S/m	Basic

ELECTROMAGNETIC WAVES, FREQUENCY DOMAIN (EMW)

Scattering Boundary Condition 1

1 In the **Physics** toolbar, click  **Boundaries** and choose **Scattering Boundary Condition**.

- 2 In the **Settings** window for **Scattering Boundary Condition**, locate the **Boundary Selection** section.
- 3 From the **Selection** list, choose **All boundaries**.
- 4 Locate the **Scattering Boundary Condition** section. From the **Scattered wave type** list, choose **Spherical wave**.

Edge Current I

- 1 In the **Physics** toolbar, click  **Edges** and choose **Edge Current**.

You are now going to apply a current on the very short edge near the center of the geometry. This will be easier if you zoom in a few times.

- 2 Click the  **Zoom In** button in the **Graphics** toolbar.
- 3 Select Edge 17 only.
- 4 In the **Model Builder** window, click **Edge Current I**.
- 5 In the **Settings** window for **Edge Current**, locate the **Edge Current** section.
- 6 In the I_0 text field, type $1e4$.

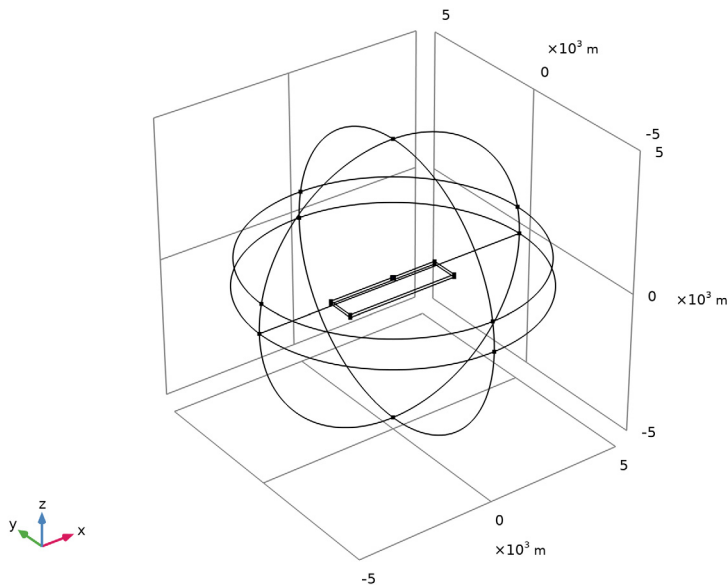

- 7 Click the  **Zoom Extents** button in the **Graphics** toolbar.

MESH I

- 1 In the **Model Builder** window, under **Component I (comp1)** click **Mesh I**.

- 2 In the **Settings** window for **Mesh**, locate the **Physics-Controlled Mesh** section.
- 3 In the table, clear the **Use** checkbox for **Electromagnetic Waves, Frequency Domain (emw)**.
- 4 From the **Element size** list, choose **Normal**.
- 5 Click  **Build All**.

STUDY 1

Step 1: Frequency Domain

- 1 In the **Model Builder** window, under **Study 1** click **Step 1: Frequency Domain**.
- 2 In the **Settings** window for **Frequency Domain**, locate the **Study Settings** section.
- 3 In the **Frequencies** text field, type 1 [Hz].
- 4 In the **Study** toolbar, click  **Compute**.

RESULTS

Proceed to reproduce [Figure 1](#).

Multislice 1

- 1 In the **Model Builder** window, expand the **Results > Electric Field (emw)** node.
- 2 Right-click **Multislice 1** and choose **Delete**.

Slice 1

- 1 Right-click **Electric Field (emw)** and choose **Slice**.
- 2 In the **Settings** window for **Slice**, locate the **Expression** section.
- 3 In the **Expression** text field, type $20 * \log_{10}(emw.normE)$.
- 4 Select the **Description** checkbox. In the associated text field, type Electric field norm, dB.
- 5 Locate the **Plane Data** section. From the **Plane** list, choose **ZX-planes**.
- 6 In the **Planes** text field, type 1.
- 7 In the **Electric Field (emw)** toolbar, click  **Plot**.

ID Plot Group 3

- 1 In the **Results** toolbar, click  **ID Plot Group**.
- 2 In the **Settings** window for **ID Plot Group**, click to expand the **Title** section.
- 3 From the **Title type** list, choose **Manual**.
- 4 In the **Title** text area, type Electric field norm, log scale.

Line Graph 1

- 1 Right-click **ID Plot Group 3** and choose **Line Graph**.
- 2 Select Edge 5 only.
- 3 In the **Settings** window for **Line Graph**, locate the **y-Axis Data** section.
- 4 In the **Expression** text field, type $20 * \log_{10}(emw.normE)$.
- 5 Click **Replace Expression** in the upper-right corner of the **x-Axis Data** section. From the menu, choose **Component 1 (comp1) > Geometry > Coordinate > x - x-coordinate**.
- 6 In the **ID Plot Group 3** toolbar, click  **Plot**.

The plot you just generated should mimic the solid line in [Figure 2](#). Proceed to compare this result with a model without the hydrocarbon reserve.

MATERIALS

Oil (mat3)

In the **Model Builder** window, under **Component 1 (comp1) > Materials** right-click **Oil (mat3)** and choose **Disable**.

STUDY 1

Solution 1 (sol1)

- 1 In the **Model Builder** window, expand the **Study 1 > Solver Configurations** node.
- 2 Right-click **Solution 1 (sol1)** and choose **Exclude When Computing Study**.
This way you get a separate solver node for the second case.
- 3 In the **Study** toolbar, click  **Compute**.

RESULTS

Multislice 1

- 1 In the **Model Builder** window, expand the **Electric Field (emw) 1** node, then click **Multislice 1**.
- 2 In the **Settings** window for **Multislice**, locate the **Expression** section.
- 3 In the **Expression** text field, type $20 * \log_{10}(emw.normE)$.
- 4 Locate the **Multipane Data** section. Find the **X-planes** subsection. In the **Planes** text field, type 0.
- 5 Find the **Z-planes** subsection. In the **Planes** text field, type 0.

6 In the **Electric Field (emw) 1** toolbar, click  **Plot**.

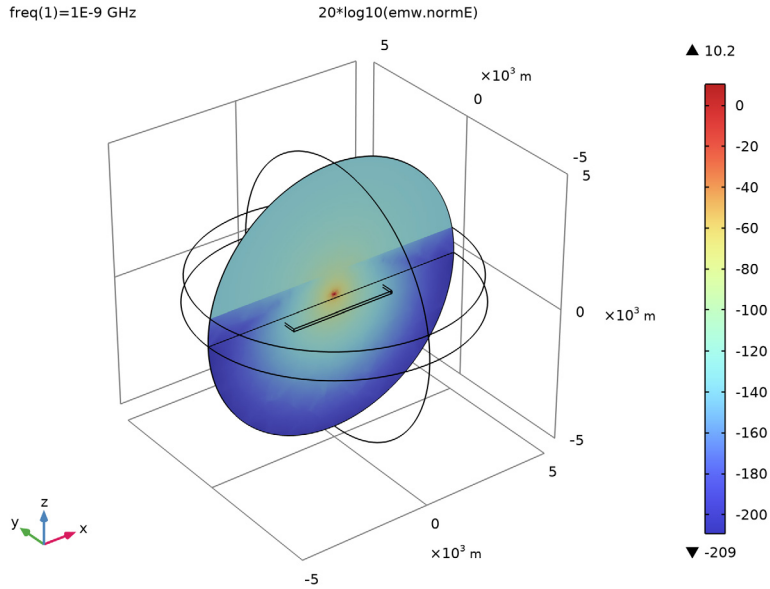

Line Graph 2

- 1 In the **Model Builder** window, right-click **ID Plot Group 3** and choose **Line Graph**.
- 2 In the **Settings** window for **Line Graph**, locate the **Data** section.
- 3 From the **Dataset** list, choose **Study 1/Solution 2 (sol2)**.
- 4 Select Edge 5 only.
- 5 Locate the **y-Axis Data** section. In the **Expression** text field, type $20 \cdot \log_{10}(\text{emw}.\text{normE})$.
- 6 Click **Replace Expression** in the upper-right corner of the **x-Axis Data** section. From the menu, choose **Component 1 (comp1) > Geometry > Coordinate > x - x-coordinate**.
- 7 Click to expand the **Coloring and Style** section. Find the **Line style** subsection. From the **Line** list, choose **Dashed**.
- 8 In the **ID Plot Group 3** toolbar, click  **Plot**.