



Model created in COMSOL Multiphysics 6.4

# High-Speed Interconnect Tuning by Time-Domain Reflectometry

## Introduction

---

In signal integrity (SI) applications, time-domain reflectometry (TDR) is a useful technique to analyze the effect of discontinuities in the signal path by observing the reflected signal strength. The signal quality is degraded mainly by impedance mismatch along the transmission line if there is no external noise source, crosstalk, or other undesired coupling. In this example, a staircase step function with a fast rise time is launched on a microstrip line connected from layer to layer through a metalized via hole. The signal path discontinuities are identified from the reflected signal. In a subsequent step, the geometry parts in the circuit, where the discontinuities are observed, are modified to lower the distortion.

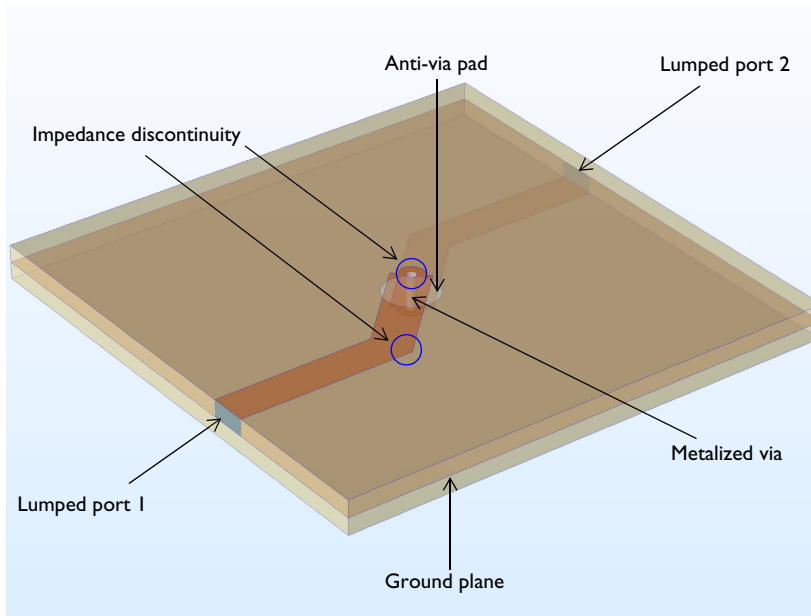

*Figure 1: A microstrip line on a multilayer circuit board. A 20 mil (0.508 mm) microwave substrate is used for each dielectric layer. The ground plane with an anti-via pad is located between two dielectric layers. The top and bottom microstrip lines are connected with a metalized via hole.*

## Model Definition

---

A ground plane with a 0.8 mm anti-via pad is shared by two 20 mil (0.508 mm) substrates with a dielectric constant  $\epsilon_r = 3.38$ . 50  $\Omega$  microstrip lines are patterned on the top and bottom surfaces of the stacked dielectric layers. The perfect electric conductor (PEC)

boundary condition is applied to all metallic parts including the patterned lines, via pad, via hole and bottom ground plane. The microstrip lines are 135° bent and connected through a metalized via.

The small rectangular surfaces, bridging the microstrip lines and ground plane, are used to model lumped ports where the microstrip lines are excited or terminated by 50 Ω. The air domain outside the circuit board is defined using vacuum material properties. The simulation domain is truncated by a scattering boundary condition that is an absorbing boundary describing an open space.

A staircase step function is used as an input signal to excite the microstrip line. To avoid undesirable high-frequency components from the signal, it is necessary to apply a long enough rise time, defined by the transition zone size of the step function. Thus, the rise time of the step function is set to one eighth of the period for the 12 Gbit/s signal.

Since the mode in the microstrip line is quasi-TEM and there is no dispersive material properties used in this model, the maximum simulation time is approximated by the traveling time for the wave passing through the microstrip line given the phase velocity. The effective dielectric constant for the phase velocity calculation is obtained using an equation in [Ref. 1](#)

$$\frac{\epsilon_r + 1}{2} + \frac{\epsilon_r - 1}{2\sqrt{1 + 12\frac{d}{W}}}$$

where  $d$  is the thickness of the substrate and  $W$  is the width of the line.

The mesh size must be small enough to resolve also the wavelengths corresponding to the highest frequencies in the signal. For this model, the maximum frequency is approximated to 96 GHz. This corresponds to a period that is half of the step function rise time. Since the wave is guided mostly between the microstrip line and the ground plane, only the maximum mesh size of the dielectric layers is set to:

$$0,2\lambda_g = 0,2\frac{c}{f_{\max}\sqrt{\epsilon_{\text{eff}}}}$$

where  $c$  is the speed of light,  $f_{\max}$  is the maximum frequency, and  $\epsilon_{\text{eff}}$  is the effective dielectric constant. The remaining area is coarsely meshed.

It is also important to define a time step that resolves the wave equally well in time as the mesh does in space. A too long time step would have a poor temporal resolution so the fast time-varying signal, especially in the smoothed transition zone, cannot be analyzed

properly while a too short time step would lead to a longer simulation time without making the results more accurate. While running a transient simulation with default solver settings, the time step is continuously adjusted to meet the specified tolerances for the time-dependent solver. For this simulation, a manual time step will be used. This is done in the settings for the Time-Dependent Solve node, as explained in the following step-by-step instructions.

After the first simulation, the corner of 135° bent part of the microstrip line is trimmed to form a mitered bend using a chamfer geometry operation. The radius of the metalized via hole is also increased. The geometry modification is performed to adjust the impedance closer to the ideal 50  $\Omega$  transmission line characteristic impedance.

### *Results and Discussion*

---

Figure 2 and Figure 3 present the voltage and impedance during the TDR simulation. The reflected wave due to the parts that have impedance discontinuities causes the signal distortions at lumped port 1. The two major impedance mismatching parts are the bent microstrip line and the metalized via hole. A mitered bend is known to reduce the discontinuity of the bent microstrip line. The undershoot of the TDR response in each plot indicates that the effective width of the microstrip line at the bent part before tuning is wider than that of the 50  $\Omega$  line. After chamfering the corner of the bent part, the undesired undershoot of the TDR response is removed. The initial radius of the metalized via hole is quite small and it is expected to have high inductance. By increasing the radius, the overshoot response from the via hole is reduced.

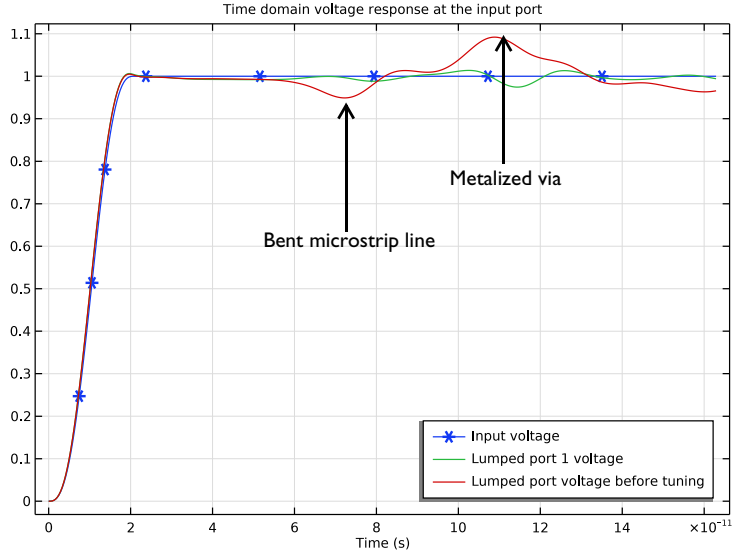

Figure 2: The time-domain voltage measured at lumped port 1. The undesired voltage fluctuation from the discontinuities is suppressed after tuning.

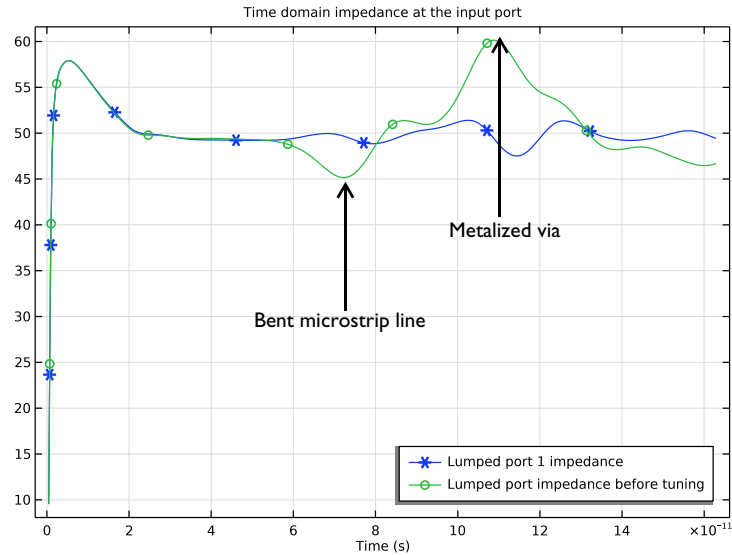

Figure 3: The time-domain impedance at lumped port 1. After tuning, the measured impedance is closer to  $50 \Omega$ .

## Reference

---

1. D.M. Pozar, *Microwave Engineering*, John Wiley & Sons, 1998.
- 

**Application Library path:** RF\_Module/EMI\_EMG\_Applications/  
high\_speed\_interconnect\_tdr

---

## Modeling Instructions



---

From the **File** menu, choose **New**.

### NEW

In the **New** window, click  **Model Wizard**.

### MODEL WIZARD

- 1 In the **Model Wizard** window, click  **3D**.
- 2 In the **Select Physics** tree, select **Radio Frequency > Electromagnetic Waves, Transient (temw)**.
- 3 Click **Add**.
- 4 Click  **Study**.
- 5 In the **Select Study** tree, select **General Studies > Time Dependent**.
- 6 Click  **Done**.

### GLOBAL DEFINITIONS

#### Parameters 1



- 1 In the **Model Builder** window, under **Global Definitions** click **Parameters 1**.
- 2 In the **Settings** window for **Parameters**, locate the **Parameters** section.
- 3 Click  **Load from File**.
- 4 Browse to the model's Application Libraries folder and double-click the file `high_speed_interconnect_tdr_parameters.txt`.

### GEOMETRY 1

- 1 In the **Model Builder** window, under **Component 1 (comp1)** click **Geometry 1**.
- 2 In the **Settings** window for **Geometry**, locate the **Units** section.

3 From the **Length unit** list, choose **mm**.

*Block 1 (blk1)*

- 1 In the **Geometry** toolbar, click  **Block**.
- 2 In the **Settings** window for **Block**, locate the **Size and Shape** section.
- 3 In the **Width** text field, type sub\_1.
- 4 In the **Depth** text field, type sub\_w.
- 5 In the **Height** text field, type sub\_t.
- 6 Locate the **Position** section. From the **Base** list, choose **Center**.
- 7 In the **z** text field, type sub\_t/2.
- 8 Click  **Build Selected**.
- 9 Click the  **Wireframe Rendering** button in the **Graphics** toolbar.

*Work Plane 1 (wp1)*

In the **Geometry** toolbar, click  **Work Plane**.



*Work Plane 1 (wp1) > Plane Geometry*

In the **Model Builder** window, click **Plane Geometry**.

*Work Plane 1 (wp1) > Rectangle 1 (r1)*

- 1 In the **Work Plane** toolbar, click  **Rectangle**.
- 2 In the **Settings** window for **Rectangle**, locate the **Size and Shape** section.
- 3 In the **Width** text field, type sub\_1/4.
- 4 In the **Height** text field, type line\_w.
- 5 Locate the **Position** section. From the **Base** list, choose **Center**.
- 6 In the **xw** text field, type -sub\_1/8.

*Work Plane 1 (wp1) > Rotate 1 (rot1)*



- 1 In the **Work Plane** toolbar, click  **Transforms** and choose **Rotate**.
- 2 Select the object **r1** only.
- 3 In the **Settings** window for **Rotate**, locate the **Rotation** section.
- 4 In the **Angle** text field, type 45.
- 5 Click  **Build Selected**.

*Work Plane 1 (wp1) > Rectangle 2 (r2)*

- 1 In the **Work Plane** toolbar, click  **Rectangle**.
- 2 In the **Settings** window for **Rectangle**, locate the **Size and Shape** section.

- 3 In the **Width** text field, type  $\text{sub\_1}/2 - \text{sub\_1}/2/2/\text{sqrt}(2) + \text{line\_w}/2/\text{sqrt}(2)$ .
- 4 In the **Height** text field, type  $\text{line\_w}$ .
- 5 Locate the **Position** section. From the **Base** list, choose **Center**.
- 6 In the **xw** text field, type  $-\text{sub\_1}/2 + (\text{sub\_1}/2 - \text{sub\_1}/2/2/\text{sqrt}(2) + \text{line\_w}/2/\text{sqrt}(2))/2$ .
- 7 In the **yw** text field, type  $-\text{sub\_1}/2/2/\text{sqrt}(2) + (\text{line\_w}/2 - \text{line\_w}/2/\text{sqrt}(2))$ .

*Work Plane 1 (wp1) > Union 1 (uni1)*

- 1 In the **Work Plane** toolbar, click  **Booleans and Partitions** and choose **Union**.
- 2 Click in the **Graphics** window and then press Ctrl+A to select both objects.
- 3 In the **Settings** window for **Union**, locate the **Union** section.
- 4 Clear the **Keep interior boundaries** checkbox.
- 5 Click  **Build Selected**.

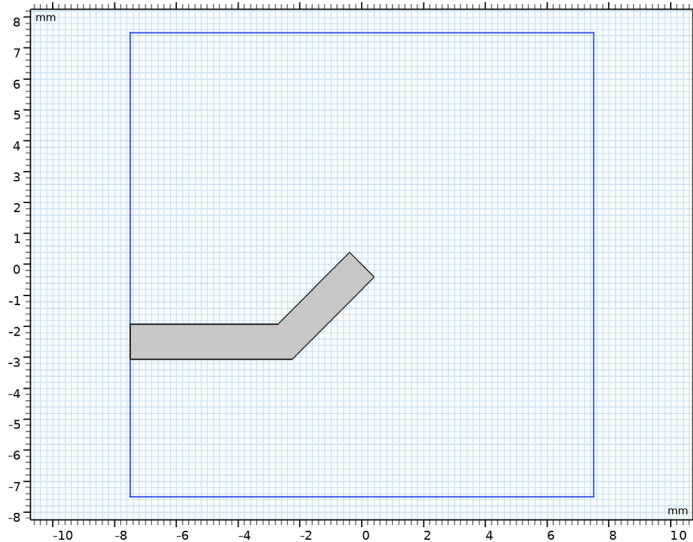

*Extrude 1 (ext1)*

- 1 In the **Model Builder** window, right-click **Geometry 1** and choose **Extrude**.
- 2 In the **Settings** window for **Extrude**, locate the **Distances** section.
- 3 In the table, enter the following settings:

<b>Distances (mm)</b>
sub_t

### *Rotate 1 (rot1)*

- 1 In the **Geometry** toolbar, click  **Transforms** and choose **Rotate**.
- 2 Click in the **Graphics** window and then press Ctrl+A to select both objects.
- 3 In the **Settings** window for **Rotate**, locate the **Input** section.
- 4 Select the **Keep input objects** checkbox.
- 5 Locate the **Rotation** section. In the **Angle** text field, type 180.

### *Cylinder 1 (cyl1)*

- 1 In the **Geometry** toolbar, click  **Cylinder**.
- 2 In the **Settings** window for **Cylinder**, locate the **Size and Shape** section.
- 3 In the **Radius** text field, type 0.15[mm].
- 4 In the **Height** text field, type sub\_t\*2.
- 5 Locate the **Position** section. In the **z** text field, type -sub\_t.
- 6 Locate the **Rotation Angle** section. In the **Rotation** text field, type 45.

### *Move 1 (mov1)*

- 1 In the **Geometry** toolbar, click  **Transforms** and choose **Move**.
- 2 Select the objects **rot1(1)** and **rot1(2)** only.
- 3 In the **Settings** window for **Move**, locate the **Displacement** section.
- 4 In the **z** text field, type -sub\_t.

### *Work Plane 2 (wp2)*

- 1 In the **Geometry** toolbar, click  **Work Plane**.
- 2 In the **Settings** window for **Work Plane**, locate the **Plane Definition** section.
- 3 In the **z-coordinate** text field, type sub\_t.

### *Work Plane 2 (wp2) > Plane Geometry*

In the **Model Builder** window, click **Plane Geometry**.

### *Work Plane 2 (wp2) > Circle 1 (c1)*

- 1 In the **Work Plane** toolbar, click  **Circle**.
- 2 In the **Settings** window for **Circle**, locate the **Size and Shape** section.
- 3 In the **Radius** text field, type 0.4[mm].

### *Copy 1 (copy1)*

- 1 In the **Model Builder** window, right-click **Geometry 1** and choose **Transforms > Copy**.
- 2 Select the object **wp2** only.

- 3 In the **Settings** window for **Copy**, locate the **Displacement** section.
- 4 In the **z** text field, type  $-\text{sub}_t \cdot 2$ .
- 5 Click  **Build Selected**.

*Work Plane 3 (wp3)*

In the **Geometry** toolbar, click  **Work Plane**.

*Work Plane 3 (wp3) > Plane Geometry*

In the **Model Builder** window, click **Plane Geometry**.

*Work Plane 3 (wp3) > Circle 1 (c1)*

- 1 In the **Work Plane** toolbar, click  **Circle**.
- 2 In the **Settings** window for **Circle**, locate the **Size and Shape** section.
- 3 In the **Radius** text field, type  $0.8[\text{mm}]$ .
- 4 Locate the **Rotation Angle** section. In the **Rotation** text field, type 45.

*Block 2 (blk2)*

- 1 In the **Model Builder** window, right-click **Geometry 1** and choose **Block**.
- 2 In the **Settings** window for **Block**, locate the **Size and Shape** section.
- 3 In the **Width** text field, type  $\text{sub}_1 + 4[\text{mm}]$ .
- 4 In the **Depth** text field, type  $\text{sub}_w$ .
- 5 In the **Height** text field, type  $\text{sub}_t \cdot 30$ .
- 6 Locate the **Position** section. From the **Base** list, choose **Center**.
- 7 Click to expand the **Layers** section. In the table, enter the following settings:

Layer name	Thickness (mm)
Layer 1	2[mm]

- 8 Find the **Layer position** subsection. Select the **Left** checkbox.
- 9 Select the **Right** checkbox.
- 10 Clear the **Bottom** checkbox.
- 11 In the **Geometry** toolbar, click  **Build All**.

12 In the **Model Builder** window, click **Geometry 1**.

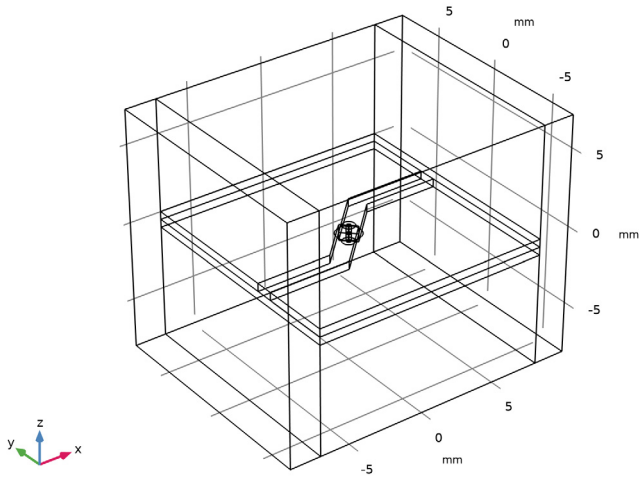

13 Click the  **Zoom Extends** button in the **Graphics** toolbar.

## DEFINITIONS

### Step 1 (step1)

- 1 In the **Definitions** toolbar, click  **More Functions** and choose **Step**.
- 2 In the **Settings** window for **Step**, click to expand the **Smoothing** section.
- 3 In the **Size of transition zone** text field, type T0/8.

### Analytic 1 (an1)

- 1 In the **Definitions** toolbar, click  **Analytic**.
- 2 In the **Settings** window for **Analytic**, locate the **Definition** section.
- 3 In the **Expression** text field, type  $\text{step1}((x - T0/16)/1[\text{s}])$ .
- 4 Locate the **Units** section. In the table, enter the following settings:

Argument	Unit
x	s

- 5 In the **Function** text field, type V.

## MATERIALS

### Material 1 (mat1)

- 1 In the **Model Builder** window, under **Component 1 (comp1)** right-click **Materials** and choose **Blank Material**.
- 2 In the **Settings** window for **Material**, locate the **Material Contents** section.
- 3 In the table, enter the following settings:

Property	Variable	Value	Unit	Property group
Relative permittivity	$\epsilon_{nr\_iso}$ ; $\epsilon_{nr_{ii}} = \epsilon_{nr\_iso}$ , $\epsilon_{nr_{ij}} = 0$	1		Basic
Relative permeability	$\mu_{r\_iso}$ ; $\mu_{r_{ii}}$ $= \mu_{r\_iso}$ , $\mu_{r_{ij}} = 0$	1		Basic
Electric conductivity	$\sigma_{iso}$ ; $\sigma_{i_{ii}} = \sigma_{iso}$ , $\sigma_{i_{ij}} = 0$	0	S/m	Basic

### Material 2 (mat2)

- 1 Right-click **Materials** and choose **Blank Material**.
- 2 In the **Settings** window for **Material**, locate the **Geometric Entity Selection** section.
- 3 Click  **Paste Selection**.
- 4 In the **Paste Selection** dialog, type 3, 4, 6, 7 in the **Selection** text field.

5 Click **OK**.

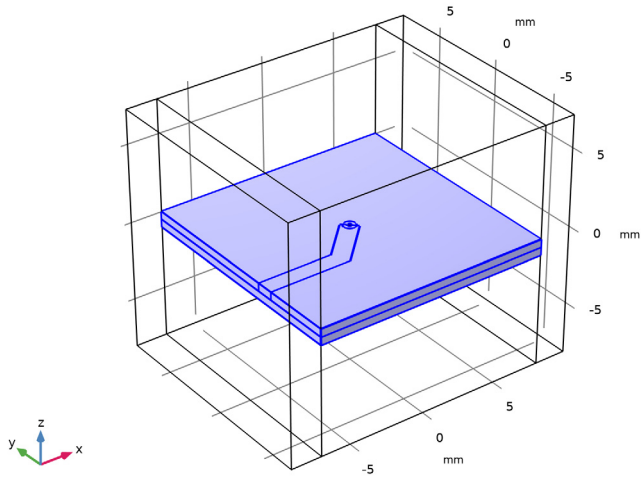

6 In the **Settings** window for **Material**, locate the **Material Contents** section.

7 In the table, enter the following settings:

Property	Variable	Value	Unit	Property group
Relative permittivity	epsilon <sub>r_</sub> iso ; epsilon <sub>r_</sub> ii = epsilon <sub>r_</sub> iso, epsilon <sub>r_</sub> ij = 0	er_sub		Basic
Relative permeability	mu <sub>r_</sub> iso ; mu <sub>r_</sub> ii = mu <sub>r_</sub> iso, mu <sub>r_</sub> ij = 0	1		Basic
Electric conductivity	sigma_iso ; sigma <sub>ii</sub> = sigma_iso, sigma <sub>ij</sub> = 0	0	S/m	Basic

## ELECTROMAGNETIC WAVES, TRANSIENT (TEMW)

### Perfect Electric Conductor 2

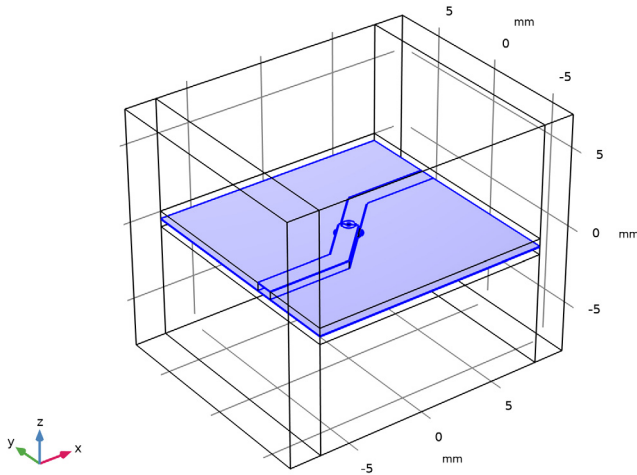

1 In the **Physics** toolbar, click  **Boundaries** and choose **Perfect Electric Conductor**.

- 2 In the **Settings** window for **Perfect Electric Conductor**, locate the **Boundary Selection** section.
- 3 Click  **Paste Selection**.
- 4 In the **Paste Selection** dialog, type 14, 21-22, 25, 34-35, 38, 41-44, 46-47, 51, 54, 58-59, 61 in the **Selection** text field.
- 5 Click **OK**.



**Perfect Electric Conductor** includes all metallic surfaces: microstrip line, metalized via, via-pad, and ground plane. Make sure that the anti-via pad on the ground plane is excluded.

#### *Scattering Boundary Condition 1*

- 1 In the **Physics** toolbar, click  **Boundaries** and choose **Scattering Boundary Condition**.
- 2 In the **Settings** window for **Scattering Boundary Condition**, locate the **Boundary Selection** section.
- 3 Click  **Paste Selection**.
- 4 In the **Paste Selection** dialog, type 1-5, 7-8, 10, 13, 16, 18, 26-29, 67-68, 72, 75-76 in the **Selection** text field.

5 Click **OK**.

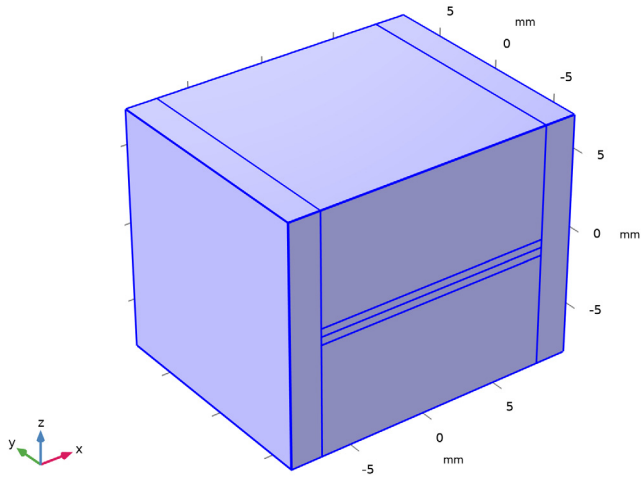



These are all exterior boundaries.

#### *Lumped Port 1*

1 In the **Physics** toolbar, click  **Boundaries** and choose **Lumped Port**.

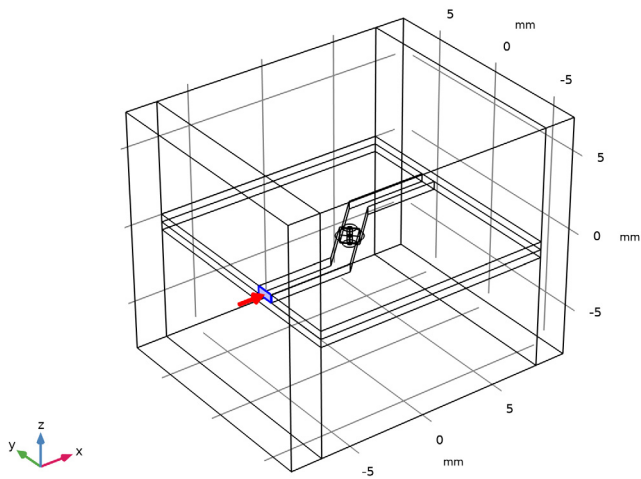
2 Select Boundary 19 only.



- 3 In the **Settings** window for **Lumped Port**, locate the **Boundary Selection** section.
- 4 Click  **Create Selection**.  
Use this selection to store solutions only on the excited **Lumped Port** boundary.
- 5 In the **Create Selection** dialog, click **OK**.  
For the first port, wave excitation is **on** by default.
- 6 In the **Settings** window for **Lumped Port**, locate the **Settings** section.
- 7 In the  $V_0$  text field, type  $an1(t)$ .

#### *Lumped Port 2*

- 1 In the **Physics** toolbar, click  **Boundaries** and choose **Lumped Port**.
- 2 Select Boundary 73 only.

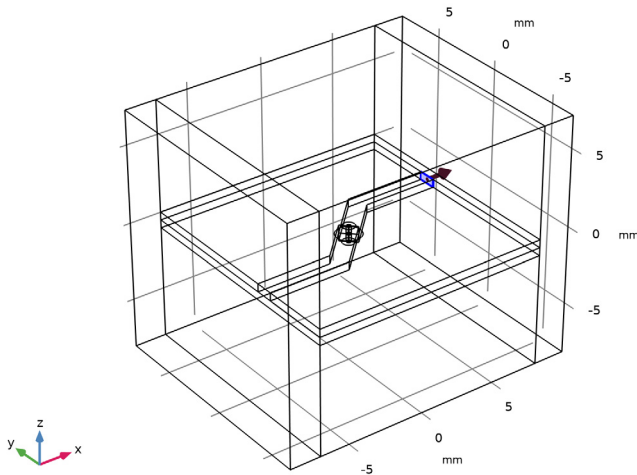

#### **MESH 1**

- 1 In the **Model Builder** window, under **Component 1 (comp1)** click **Mesh 1**.
- 2 In the **Settings** window for **Mesh**, locate the **Electromagnetic Waves, Transient (temw)** section.
- 3 In the **Maximum element size in free space** text field, type  $5[\text{mm}]$ .
- 4 In the **Model Builder** window, click **Mesh 1**.
- 5 Locate the **Physics-Controlled Mesh** section. In the table, clear the **Use** checkbox for **Geometric Analysis, Detail Size**.

6 Locate the **Sequence Type** section. From the list, choose **User-controlled mesh**.

*Size*

1 In the **Model Builder** window, under **Component 1 (comp1) > Mesh 1** click **Size**.

2 In the **Settings** window for **Size**, locate the **Element Size** section.

3 Click the **Custom** button.

4 Locate the **Element Size Parameters** section. In the **Maximum element size** text field, type 5.

5 In the **Minimum element size** text field, type 0.5.

6 In the **Maximum element growth rate** text field, type 2.

*Size 1*

1 In the **Model Builder** window, click **Size 1**.

2 In the **Settings** window for **Size**, locate the **Geometric Entity Selection** section.

3 Click  **Clear Selection**.

4 Click  **Paste Selection**.

5 In the **Paste Selection** dialog, type 6-11 in the **Selection** text field.

6 Click **OK**.

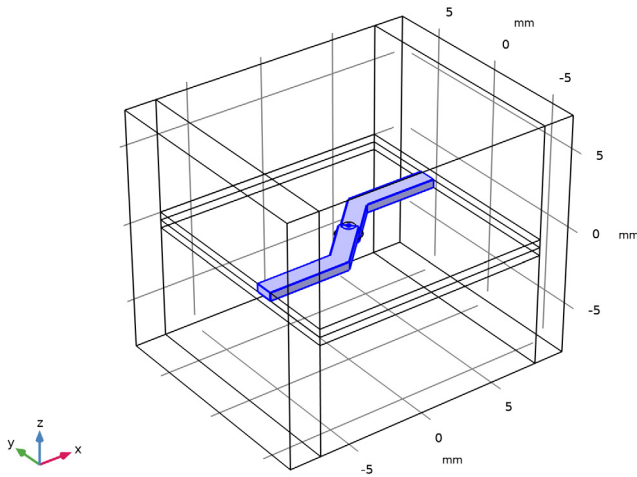

7 In the **Settings** window for **Size**, locate the **Element Size Parameters** section.

8 In the **Maximum element size** text field, type  $h_{max}$ .

9 In the **Minimum element size** text field, type  $h_{max}/2$ .

*Size 3*

1 In the **Model Builder** window, right-click **Mesh 1** and choose **Size**.

2 In the **Settings** window for **Size**, locate the **Geometric Entity Selection** section.

3 From the **Geometric entity level** list, choose **Boundary**.

4 Click  **Paste Selection**.

5 In the **Paste Selection** dialog, type 32-33, 40, 57 in the **Selection** text field.

6 Click **OK**.

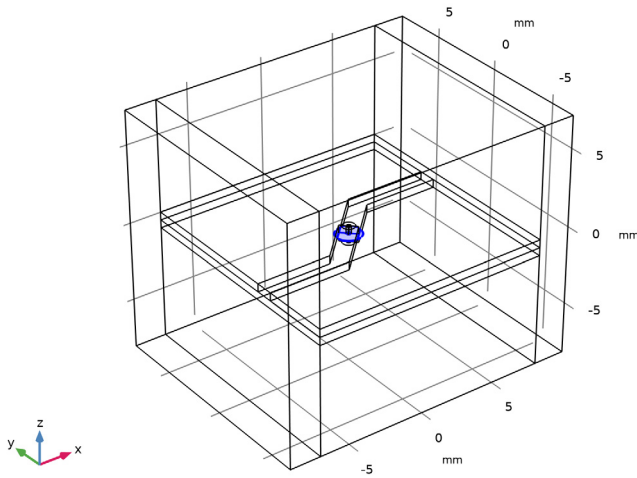

7 In the **Settings** window for **Size**, locate the **Element Size** section.

8 Click the **Custom** button.

9 Locate the **Element Size Parameters** section.

10 Select the **Maximum element size** checkbox. In the associated text field, type  $h_{max}$ .

11 Select the **Minimum element size** checkbox. In the associated text field, type  $h_{max}/3$ .

12 In the **Model Builder** window, right-click **Size 3** and choose **Move Up**.

## DEFINITIONS

*Hide for Physics 1*

1 In the **Model Builder** window, right-click **View 1** and choose **Hide for Physics**.

2 Select Domains 1, 2, 5, and 12 only.

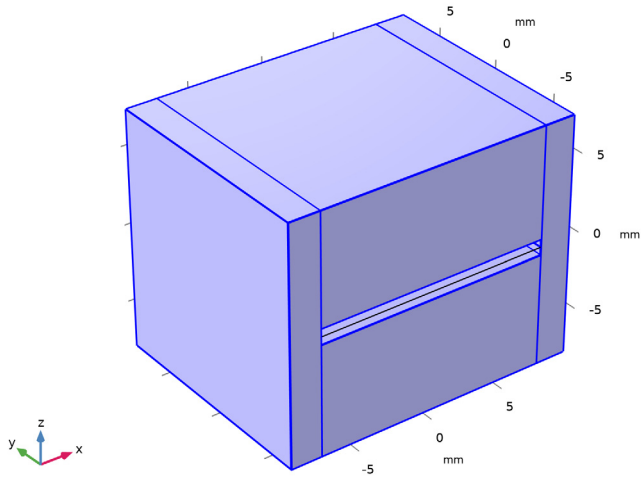

### MESH 1

1 In the **Model Builder** window, under **Component 1 (comp1)** right-click **Mesh 1** and choose **Build All**.

2 Click the  **Zoom Extents** button in the **Graphics** toolbar.

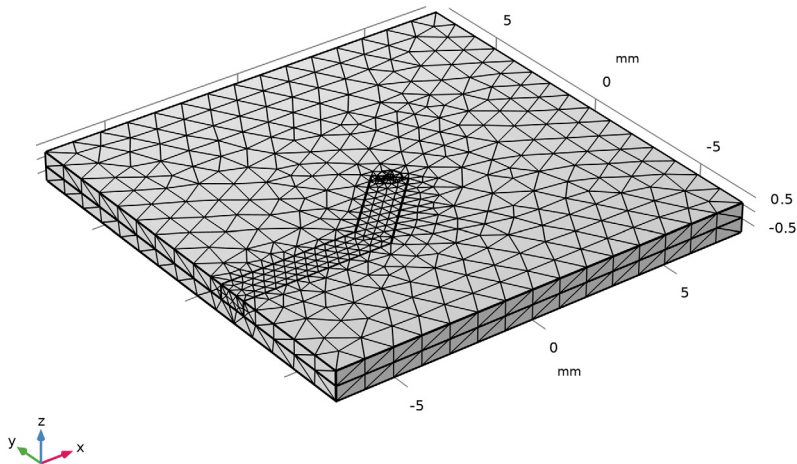

## STUDY 1

*Step 1: Time Dependent*



- 1 In the **Model Builder** window, under **Study 1** click **Step 1: Time Dependent**.
- 2 In the **Settings** window for **Time Dependent**, locate the **Study Settings** section.
- 3 In the **Output times** text field, type `range(0,sim_time_step,sim_time_max)`.
- 4 Click to expand the **Store in Output** section. In the table, enter the following settings:

Interface	Output
Electromagnetic Waves, Transient (temw)	Selection

- 5 Click to select the first row in the table.
- 6 Under **Selections**, click  **Add**.
- 7 In the **Add** dialog, select **Explicit 1** in the **Selections** list.
- 8 Click **OK**.
- 9 In the **Model Builder** window, click **Study 1**.
- 10 In the **Settings** window for **Study**, locate the **Study Settings** section.

11 Clear the **Generate default plots** checkbox.

#### *Solution 1 (sol1)*

- 1 In the **Study** toolbar, click  **Show Default Solver**.
- 2 In the **Model Builder** window, expand the **Solution 1 (sol1)** node, then click **Time-Dependent Solver 1**.
- 3 In the **Settings** window for **Time-Dependent Solver**, click to expand the **Time Stepping** section.
- 4 From the **Steps taken by solver** list, choose **Manual**.
- 5 In the **Time step** text field, type `sim_time_step`.
- 6 In the **Study** toolbar, click  **Compute**.

## RESULTS

#### *ID Plot Group 1*

- 1 In the **Results** toolbar, click  **ID Plot Group**.
- 2 In the **Settings** window for **ID Plot Group**, click to expand the **Title** section.
- 3 From the **Title type** list, choose **Manual**.
- 4 In the **Title** text area, type Time domain voltage response at the input port.
- 5 Locate the **Legend** section. From the **Position** list, choose **Lower right**.

#### *Global 1*

- 1 Right-click **ID Plot Group 1** and choose **Global**.
- 2 In the **Settings** window for **Global**, locate the **y-Axis Data** section.
- 3 In the table, enter the following settings:

Expression	Unit	Description
<code>an1(t)</code>	V	Input voltage

- 4 Click to expand the **Coloring and Style** section. Find the **Line markers** subsection. From the **Marker** list, choose **Cycle**.
- 5 From the **Positioning** list, choose **Interpolated**.

#### *Global 2*

- 1 In the **Model Builder** window, right-click **ID Plot Group 1** and choose **Global**.
- 2 In the **Settings** window for **Global**, click **Add Expression** in the upper-right corner of the **y-Axis Data** section. From the menu, choose **Component 1 (comp1) >**

**Electromagnetic Waves, Transient > Ports > Voltage > temw.Vport\_1 -  
Lumped port 1 voltage - V.**

- 3 In the **ID Plot Group 1** toolbar, click  **Plot**.

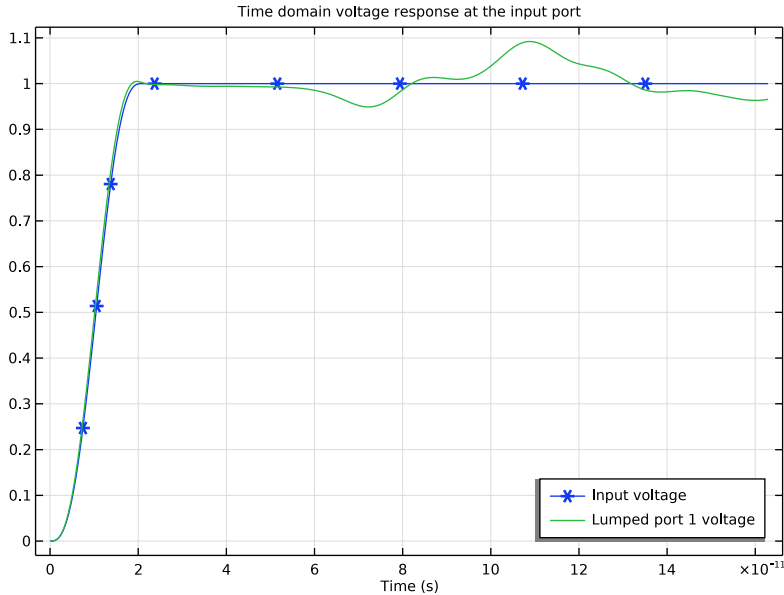

The plot shows the input and measured voltage at lumped port 1. The fluctuation in the measured voltage at lumped port 1 indicates that the reflected wave from the discontinuities causes the signal distortion. The discontinuities are at the bent microstrip line and metalized via hole.

*ID Plot Group 2*

- 1 In the **Results** toolbar, click  **ID Plot Group**.
- 2 In the **Settings** window for **ID Plot Group**, locate the **Data** section.
- 3 From the **Time selection** list, choose **From list**.
- 4 In the **Times (s)** list, choose **4.1667E-13, 8.3333E-13, 1.25E-12, 1.6667E-12, 2.0833E-12, 2.5E-12, 2.9167E-12, 3.3333E-12, 3.75E-12, 4.1667E-12, 4.5833E-12, 5E-12, 5.4167E-12, 5.8333E-12, 6.25E-12, 6.6667E-12, 7.0833E-12, 7.5E-12, 7.9167E-12, 8.3333E-12, 8.75E-12, 9.1667E-12, 9.5833E-12, 1E-11, 1.0417E-11, 1.0833E-11, 1.125E-11, 1.1667E-11, 1.2083E-11, 1.25E-11, 1.2917E-11, 1.3333E-11, 1.375E-11, 1.4167E-11, 1.4583E-11, 1.5E-11, 1.5417E-11, 1.5833E-11, 1.625E-11, 1.6667E-11, 1.7083E-11, 1.75E-11, 1.7917E-11, 1.8333E-11, 1.875E-11, 1.9167E-11, 1.9583E-11, 2E-11, 2.0417E-11, 2.0833E-11, 2.125E-11, 2.1667E-11, 2.2083E-11, 2.25E-11, 2.2917E-11, 2.3333E-11, 2.375E-11, 2.4167E-11,**

2.4583E-11, 2.5E-11, 2.5417E-11, 2.5833E-11, 2.625E-11, 2.6667E-11, 2.7083E-11, 2.75E-11, 2.7917E-11, 2.8333E-11, 2.875E-11, 2.9167E-11, 2.9583E-11, 3E-11, 3.0417E-11, 3.0833E-11, 3.125E-11, 3.1667E-11, 3.2083E-11, 3.25E-11, 3.2917E-11, 3.3333E-11, 3.375E-11, 3.4167E-11, 3.4583E-11, 3.5E-11, 3.5417E-11, 3.5833E-11, 3.625E-11, 3.6667E-11, 3.7083E-11, 3.75E-11, 3.7917E-11, 3.8333E-11, 3.875E-11, 3.9167E-11, 3.9583E-11, 4E-11, 4.0417E-11, 4.0833E-11, 4.125E-11, 4.1667E-11, 4.2083E-11, 4.25E-11, 4.2917E-11, 4.3333E-11, 4.375E-11, 4.4167E-11, 4.4583E-11, 4.5E-11, 4.5417E-11, 4.5833E-11, 4.625E-11, 4.6667E-11, 4.7083E-11, 4.75E-11, 4.7917E-11, 4.8333E-11, 4.875E-11, 4.9167E-11, 4.9583E-11, 5E-11, 5.0417E-11, 5.0833E-11, 5.125E-11, 5.1667E-11, 5.2083E-11, 5.25E-11, 5.2917E-11, 5.3333E-11, 5.375E-11, 5.4167E-11, 5.4583E-11, 5.5E-11, 5.5417E-11, 5.5833E-11, 5.625E-11, 5.6667E-11, 5.7083E-11, 5.75E-11, 5.7917E-11, 5.8333E-11, 5.875E-11, 5.9167E-11, 5.9583E-11, 6E-11, 6.0417E-11, 6.0833E-11, 6.125E-11, 6.1667E-11, 6.2083E-11, 6.25E-11, 6.2917E-11, 6.3333E-11, 6.375E-11, 6.4167E-11, 6.4583E-11, 6.5E-11, 6.5417E-11, 6.5833E-11, 6.625E-11, 6.6667E-11, 6.7083E-11, 6.75E-11, 6.7917E-11, 6.8333E-11, 6.875E-11, 6.9167E-11, 6.9583E-11, 7E-11, 7.0417E-11, 7.0833E-11, 7.125E-11, 7.1667E-11, 7.2083E-11, 7.25E-11, 7.2917E-11, 7.3333E-11, 7.375E-11, 7.4167E-11, 7.4583E-11, 7.5E-11, 7.5417E-11, 7.5833E-11, 7.625E-11, 7.6667E-11, 7.7083E-11, 7.75E-11, 7.7917E-11, 7.8333E-11, 7.875E-11, 7.9167E-11, 7.9583E-11, 8E-11, 8.0417E-11, 8.0833E-11, 8.125E-11, 8.1667E-11, 8.2083E-11, 8.25E-11, 8.2917E-11, 8.3333E-11, 8.375E-11, 8.4167E-11, 8.4583E-11, 8.5E-11, 8.5417E-11, 8.5833E-11, 8.625E-11, 8.6667E-11, 8.7083E-11, 8.75E-11, 8.7917E-11, 8.8333E-11, 8.875E-11, 8.9167E-11, 8.9583E-11, 9E-11, 9.0417E-11, 9.0833E-11, 9.125E-11, 9.1667E-11, 9.2083E-11, 9.25E-11, 9.2917E-11, 9.3333E-11, 9.375E-11, 9.4167E-11, 9.4583E-11, 9.5E-11, 9.5417E-11, 9.5833E-11, 9.625E-11, 9.6667E-11, 9.7083E-11, 9.75E-11, 9.7917E-11, 9.8333E-11, 9.875E-11, 9.9167E-11, 9.9583E-11, 1E-10, 1.0042E-10, 1.0083E-10, 1.0125E-10, 1.0167E-10, 1.0208E-10, 1.025E-10, 1.0292E-10, 1.0333E-10, 1.0375E-10, 1.0417E-10, 1.0458E-10, 1.05E-10, 1.0542E-10, 1.0583E-10, 1.0625E-10, 1.0667E-10, 1.0708E-10, 1.075E-10, 1.0792E-10, 1.0833E-10, 1.0875E-10, 1.0917E-10, 1.0958E-10, 1.1E-10, 1.1042E-10, 1.1083E-10, 1.1125E-10, 1.1167E-10, 1.1208E-10, 1.125E-10, 1.1292E-10, 1.1333E-10, 1.1375E-10, 1.1417E-10, 1.1458E-10, 1.15E-10, 1.1542E-10, 1.1583E-10, 1.1625E-10, 1.1667E-10, 1.1708E-10, 1.175E-10, 1.1792E-10, 1.1833E-10, 1.1875E-10, 1.1917E-10, 1.1958E-10, 1.2E-10, 1.2042E-10, 1.2083E-10, 1.2125E-10, 1.2167E-10, 1.2208E-10, 1.225E-10, 1.2292E-10, 1.2333E-10, 1.2375E-10, 1.2417E-10, 1.2458E-10, 1.25E-10, 1.2542E-10, 1.2583E-10, 1.2625E-10, 1.2667E-10, 1.2708E-10, 1.275E-10, 1.2792E-10, 1.2833E-10, 1.2875E-10, 1.2917E-10, 1.2958E-10, 1.3E-10, 1.3042E-10, 1.3083E-10, 1.3125E-10, 1.3167E-10, 1.3208E-10, 1.325E-10, 1.3292E-10, 1.3333E-10, 1.3375E-10, 1.3417E-10, 1.3458E-10, 1.35E-10, 1.3542E-10, 1.3583E-10, 1.3625E-10, 1.3667E-10, 1.3708E-10, 1.375E-10, 1.3792E-10, 1.3833E-10, 1.3875E-10, 1.3917E-10, 1.3958E-10, 1.4E-10, 1.4042E-10, 1.4083E-10, 1.4125E-10,

1.4167E-10, 1.4208E-10, 1.425E-10, 1.4292E-10, 1.4333E-10, 1.4375E-10, 1.4417E-10, 1.4458E-10, 1.45E-10, 1.4542E-10, 1.4583E-10, 1.4625E-10, 1.4667E-10, 1.4708E-10, 1.475E-10, 1.4792E-10, 1.4833E-10, 1.4875E-10, 1.4917E-10, 1.4958E-10, 1.5E-10, 1.5042E-10, 1.5083E-10, 1.5125E-10, 1.5167E-10, 1.5208E-10, 1.525E-10, 1.5292E-10, 1.5333E-10, 1.5375E-10, 1.5417E-10, 1.5458E-10, 1.55E-10, 1.5542E-10, 1.5583E-10, 1.5625E-10, 1.5667E-10, 1.5708E-10, 1.575E-10, 1.5792E-10, 1.5833E-10, 1.5875E-10, 1.5917E-10, 1.5958E-10, 1.6E-10, 1.6042E-10, 1.6083E-10, 1.6125E-10, 1.6167E-10, 1.6208E-10, 1.625E-10, and 1.6292E-10.

Select all time steps except for zero second where the evaluated value might be affected by system noise.

- 5 Locate the **Title** section. From the **Title type** list, choose **Manual**.
- 6 In the **Title** text area, type Time domain impedance at the input port.
- 7 Locate the **Legend** section. From the **Position** list, choose **Lower right**.

#### *Global I*

- 1 Right-click **ID Plot Group 2** and choose **Global**.
- 2 In the **Settings** window for **Global**, click **Add Expression** in the upper-right corner of the **y-Axis Data** section. From the menu, choose **Component I (comp1) > Electromagnetic Waves, Transient > Ports > Impedance > temw.Zport\_I - Lumped port I impedance -  $\Omega$** .
- 3 Locate the **Coloring and Style** section. Find the **Line markers** subsection. From the **Marker** list, choose **Cycle**.
- 4 From the **Positioning** list, choose **Interpolated**.

5 In the **ID Plot Group 2** toolbar, click  **Plot**.

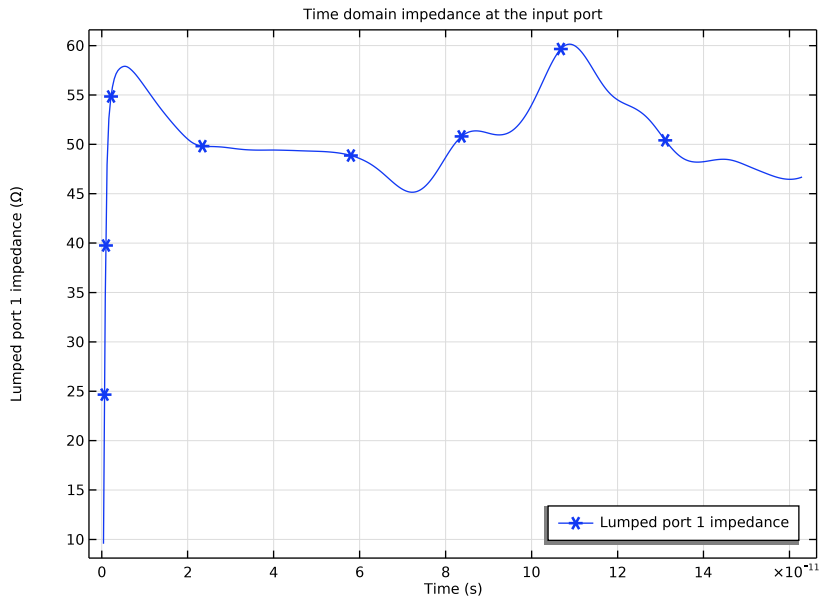

The impedance at lumped port 1 fluctuates around 50  $\Omega$ .

Improve the time domain response by tuning the parts where the impedance mismatching is observed.

## GEOMETRY I

*Work Plane 1 (wp1) > Plane Geometry*

In the **Model Builder** window, under **Component 1 (comp1) > Geometry 1 > Work Plane 1 (wp1)** click **Plane Geometry**.

*Work Plane 1 (wp1) > Chamfer 1 (cha1)*

- 1 In the **Work Plane** toolbar, click  **Chamfer**.
- 2 On the object **uni1**, select Point 4 only.
- 3 In the **Settings** window for **Chamfer**, locate the **Distance** section.
- 4 In the **Distance from vertex** text field, type 0.8.

5 Click  **Build Selected.**

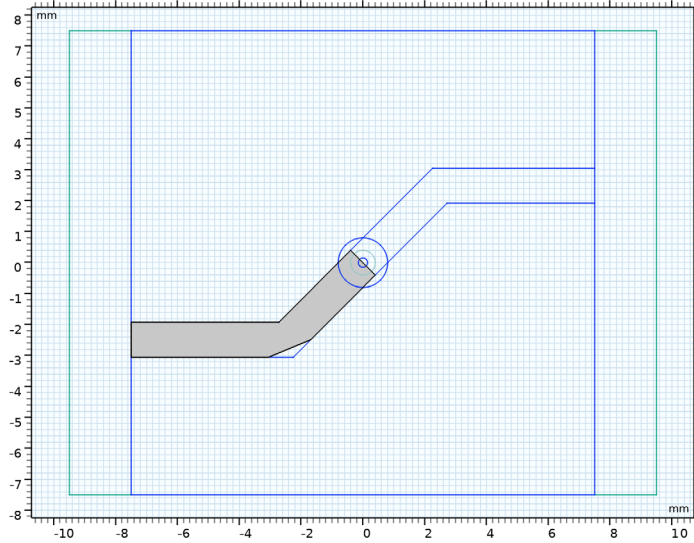

*Cylinder 1 (cyl1)*

- 1 In the **Model Builder** window, under **Component 1 (comp1) > Geometry 1** click **Cylinder 1 (cyl1)**.
- 2 In the **Settings** window for **Cylinder**, locate the **Size and Shape** section.
- 3 In the **Radius** text field, type 0.3[mm].

- 4 Click  **Build All Objects**.

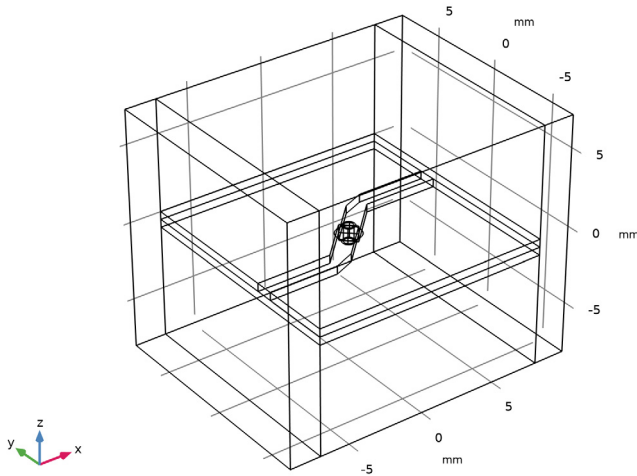

## STUDY 1

### *Solution 1 (sol1)*

- 1 In the **Model Builder** window, under **Study 1 > Solver Configurations** right-click **Solution 1 (sol1)** and choose **Solution > Copy**.

The solution from the previous simulation will be used to compare with the results of the tuned device.

- 2 In the **Study** toolbar, click  **Compute**.

## RESULTS

### *Global 3*

- 1 Right-click **ID Plot Group 1** and choose **Global**.
- 2 In the **Settings** window for **Global**, locate the **Data** section.
- 3 From the **Dataset** list, choose **Study 1/Solution 1 - Copy 1 (sol2)**.
- 4 Click **Add Expression** in the upper-right corner of the **y-Axis Data** section. From the menu, choose **Component 1 (comp1) > Electromagnetic Waves, Transient > Ports > Voltage > temw.Vport\_1 - Lumped port 1 voltage - V**.

5 Locate the **y-Axis Data** section. In the table, enter the following settings:

Expression	Unit	Description
temw.Vport_1	V	Lumped port voltage before tuning

6 In the **ID Plot Group 1** toolbar, click  **Plot**.

In [Figure 2](#), the input pulse and the voltage at lumped port 1 are plotted. After tuning of the circuit, the fluctuation of the voltage is less.

### Global 2

1 In the **Model Builder** window, under **Results** > **ID Plot Group 2** right-click **Global 1** and choose **Duplicate**.

2 In the **Settings** window for **Global**, locate the **Data** section.

3 From the **Dataset** list, choose **Study 1/Solution 1 - Copy 1 (sol2)**.

Select all time steps except for zero second where the evaluated value might be affected by system noise.

4 Locate the **y-Axis Data** section. In the table, enter the following settings:

Expression	Unit	Description
temw.Zport_1	$\Omega$	Lumped port impedance before tuning

5 In the **ID Plot Group 2** toolbar, click  **Plot**.

[Figure 3](#) shows the impedance at lumped port 1. After tuning of the circuit, the impedance is closer to 50  $\Omega$ .

Though the solutions are available only on the lumped port boundary for this model, 3D visualization of the circuit board is still possible.

### 3D Plot Group 3

1 In the **Results** toolbar, click  **3D Plot Group**.

2 In the **Settings** window for **3D Plot Group**, locate the **Plot Settings** section.

3 Clear the **Plot dataset edges** checkbox.

4 Locate the **Color Legend** section. Clear the **Show legends** checkbox.

### Surface 1

1 Right-click **3D Plot Group 3** and choose **Surface**.

2 In the **Settings** window for **Surface**, locate the **Expression** section.

3 In the **Expression** text field, type 1.

### *Selection 1*

Right-click **Surface 1** and choose **Selection**.

## **ELECTROMAGNETIC WAVES, TRANSIENT (TEMW)**

### *Perfect Electric Conductor 2*

- 1 In the **Settings** window for **Perfect Electric Conductor**, locate the **Boundary Selection** section.
- 2 Click  **Copy Selection**.

## **RESULTS**

### *Selection 1*

- 1 In the **Model Builder** window, under **Results > 3D Plot Group 3 > Surface 1** click **Selection 1**.
- 2 In the **Settings** window for **Selection**, locate the **Selection** section.
- 3 Click  **Paste Selection**.
- 4 In the **Paste Selection** dialog, type 14, 21, 22, 25, 35, 36, 39, 42-45, 47, 48, 52, 55, 59, 60, 62 in the **Selection** text field.
- 5 Click **OK**.

### *Material Appearance 1*

- 1 In the **Model Builder** window, right-click **Surface 1** and choose **Material Appearance**.
- 2 In the **Settings** window for **Material Appearance**, locate the **Appearance** section.
- 3 From the **Appearance** list, choose **Custom**.
- 4 From the **Material type** list, choose **Rose gold**.
- 5 In the **3D Plot Group 3** toolbar, click  **Plot**.

### *Surface 2*

- 1 In the **Model Builder** window, right-click **3D Plot Group 3** and choose **Surface**.
- 2 In the **Settings** window for **Surface**, locate the **Expression** section.
- 3 In the **Expression** text field, type 1.

### *Selection 1*

- 1 Right-click **Surface 2** and choose **Selection**.
- 2 Select Boundaries 9–13, 17, 23, 27, 28, 71, 72, and 76 only.

### *Material Appearance 1*

- 1 In the **Model Builder** window, right-click **Surface 2** and choose **Material Appearance**.

- 2 In the **Settings** window for **Material Appearance**, locate the **Appearance** section.
- 3 From the **Appearance** list, choose **Custom**.
- 4 From the **Color** list, choose **Gray**.

*Transparency 1*

Right-click **Surface 2** and choose **Transparency**.

Time=1.6292E-10 s

Surface: 1 (1) Surface: 1 (1)

