



Model created in COMSOL Multiphysics 6.4

Two-Arm Helical Antenna

Introduction

A helical antenna has two major modes. One is normal mode and the other is axial mode. When the helical antenna is operating at the normal mode, its far-field radiation pattern is similar to the torus-shaped pattern of a classic dipole antenna. At the axial mode, the helical antenna is resonant at a much higher frequency band than at the normal mode operation; it works similarly to an end-fire array along the z -axis, generating a directive radiation pattern. This example analyzes a helical antenna at these two different modes. The S-parameters and far-field patterns are calculated at both operating modes, 385 MHz and 4.77 GHz.

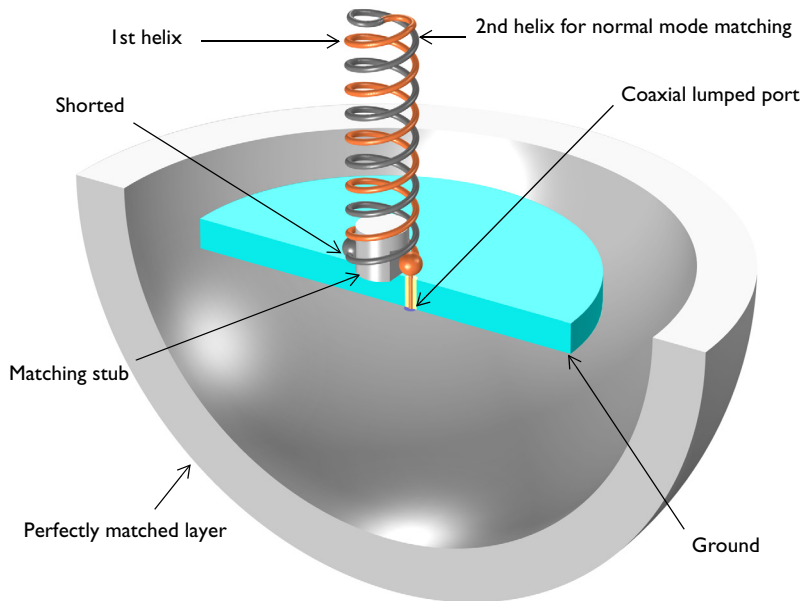

Figure 1: Each end of the two-arm helix is connected to a coaxial cable feed and ground plate. A region of free space bounded by a perfectly matched layer (PML) surrounding the antenna. The ground plate and PML are partially visualized.

Model Definition

The model consists of a two-arm helix radiator, a circular ground plate, a tuning stub, a coaxial cable, and a perfectly matched layer (PML) enclosing an air region. One bottom end of the helix arm is connected to the inner conductor pin from the coaxial cable and the other end is shorted to the ground plate. Two helix structures are wound along the z -axis and meet at the top end. The impedance of a single-helix antenna is much lower than

50 Ω when it is resonant at the normal mode. By adding an additional helix shorted to the ground, the antenna works as a folded antenna which is known for its four times bigger input resistance than that of a same size dipole antenna, and the low impedance can be adjusted close to the reference impedance of the coaxial cable, 50 Ω . An additional impedance matching stub for the axial mode is located at the center of the ground plate.

All metal parts in this example are modeled as perfect electric conductors (PEC) and their interior domains are not included in the analysis. The space between the inner and outer conductor of the coaxial cable is filled with polytetrafluoroethylene (PTFE), a material with relative permittivity $\epsilon_r = 2.1$. A coaxial type lumped port is used to excite the antenna.

All domains except the PML are meshed by a tetrahedral mesh with approximately five elements per wavelength. The helix and coaxial cable are meshed more finely to provide good resolution of the curved surfaces. The PML is swept with a total of five elements along the radial direction.

The ground plate, the PML sphere shell, and the maximum mesh size are adjusted automatically as a function of wavelength for each helical antenna mode.

Results and Discussion

The antenna is analyzed for two operating modes. [Figure 2](#) and [Figure 3](#) show the log-scaled electric field norm describing the field intensity around the antenna at the axial mode and normal mode, respectively. [Figure 4](#) shows a polar plot of 2D radiation patterns in the yz -plane for both modes. A directional radiation pattern is observed at the axial mode while the radiation pattern at the normal mode resembles the E-plane pattern of a classic dipole antenna. The 3D far-field radiation pattern for each mode is also plotted in [Figure 5](#) and [Figure 6](#). The S-parameters for both modes are less than -10 dB.

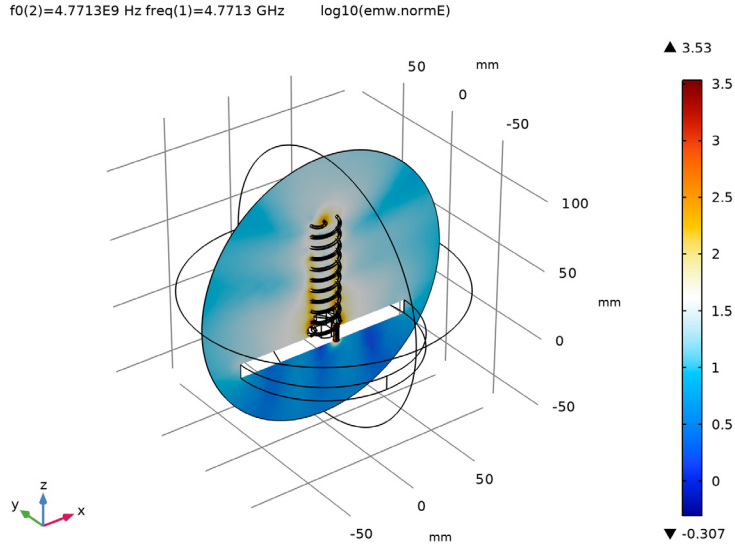

Figure 2: Log-scaled electric field magnitude around the antenna at 4.77 GHz.

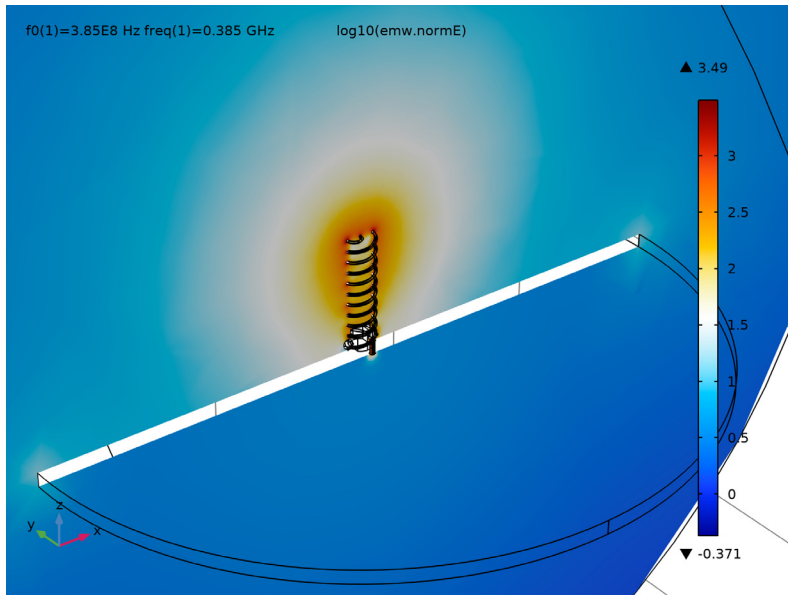

Figure 3: Log-scaled electric field magnitude around the antenna at 385 MHz.

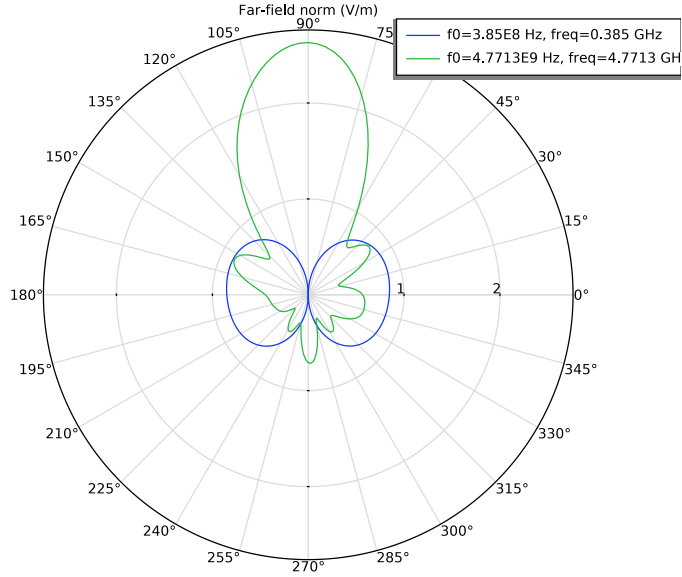

Figure 4: Polar plot of the far-field pattern in the yz-plane.

f0(2)=4.7713E9 Hz freq(1)=4.7713 GHz Realized far-field gain, dBi (dB)

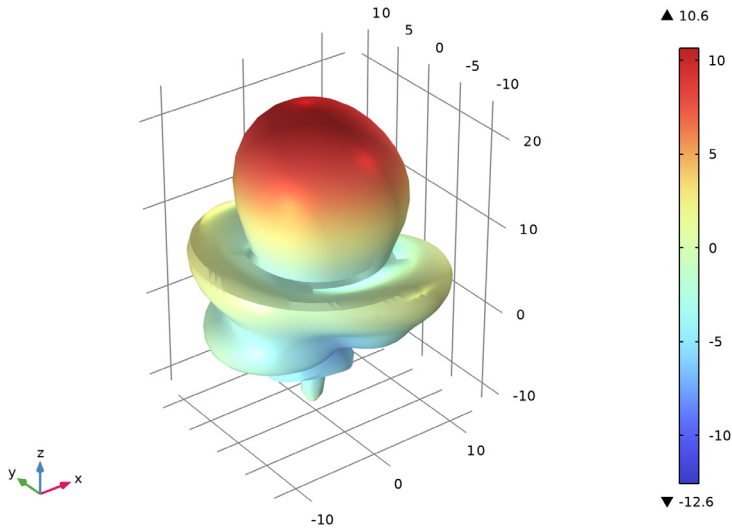

Figure 5: The 3D far-field pattern looks like that of an end-fire array along the z-axis backed by a ground plane.

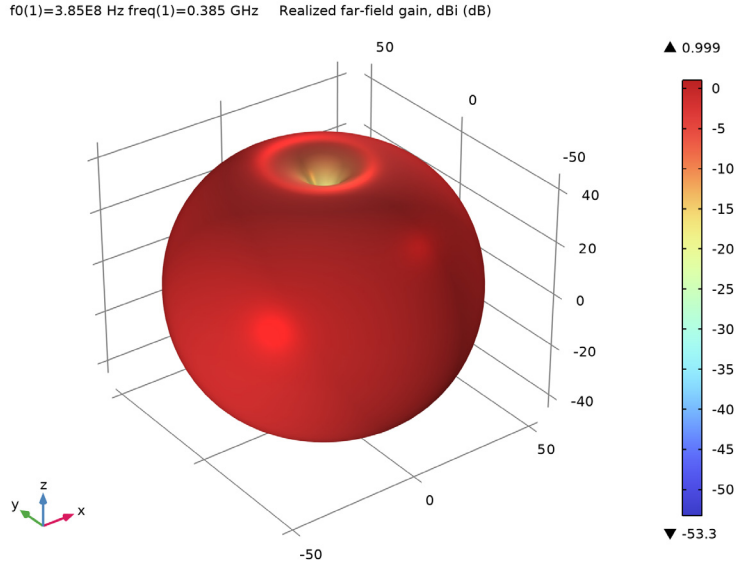

Figure 6: The torus-shaped 3D far-field pattern resembles that of a dipole antenna.

Notes About the COMSOL Implementation

Due to the complexity of the geometry and mesh, more than 7 GB RAM is required to run this example.

Application Library path: RF_Module/Antennas/helical_antenna

Modeling Instructions



From the **File** menu, choose **New**.

NEW

In the **New** window, click  **Model Wizard**.

MODEL WIZARD

I In the **Model Wizard** window, click  **3D**.

- 2 In the **Select Physics** tree, select **Radio Frequency > Electromagnetic Waves, Frequency Domain (emw)**.
- 3 Click **Add**.
- 4 Click  **Study**.
- 5 In the **Select Study** tree, select **General Studies > Frequency Domain**.
- 6 Click  **Done**.

GLOBAL DEFINITIONS

Parameters 1

- 1 In the **Model Builder** window, under **Global Definitions** click **Parameters 1**.
- 2 In the **Settings** window for **Parameters**, locate the **Parameters** section.
- 3 Click  **Load from File**.
- 4 Browse to the model's Application Libraries folder and double-click the file `helical_antenna_parameters.txt`.
Here, `c_const` is a predefined COMSOL constant for the speed of light in vacuum.

STUDY 1

Step 1: Frequency Domain

Define the study frequency ahead of performing any frequency-dependent operation such as building mesh. The physics-controlled mesh uses the specified frequency value.

- 1 In the **Model Builder** window, under **Study 1** click **Step 1: Frequency Domain**.
- 2 In the **Settings** window for **Frequency Domain**, locate the **Study Settings** section.
- 3 In the **Frequencies** text field, type `f0`.

GEOMETRY 1

- 1 In the **Model Builder** window, under **Component 1 (comp1)** click **Geometry 1**.
- 2 In the **Settings** window for **Geometry**, locate the **Units** section.
- 3 From the **Length unit** list, choose **mm**.

Create a helix with the specified parameters.

Helix 1 (hell)

- 1 In the **Geometry** toolbar, click  **Helix**.
- 2 In the **Settings** window for **Helix**, locate the **Size and Shape** section.
- 3 In the **Number of turns** text field, type `n_turn`.

4 In the **Major radius** text field, type r_{helix} .

5 In the **Minor radius** text field, type 1.

6 In the **Axial pitch** text field, type a_{pitch} .

Add a torus connected to one end the helix.

Torus 1 (tor1)

1 In the **Geometry** toolbar, click  **Torus**.

2 In the **Settings** window for **Torus**, locate the **Size and Shape** section.

3 In the **Major radius** text field, type $r_{\text{helix}}/2$.

4 In the **Minor radius** text field, type 1.

5 In the **Revolution angle** text field, type 180.

6 Locate the **Position** section. In the **x** text field, type $r_{\text{helix}}/2$.

7 In the **z** text field, type $a_{\text{pitch}}*n_{\text{turn}}$.

Add a cylinder for the extended part of the coaxial cable inner conductor and ground pin.

Cylinder 1 (cyl1)

1 In the **Geometry** toolbar, click  **Cylinder**.

2 In the **Settings** window for **Cylinder**, locate the **Size and Shape** section.

3 In the **Radius** text field, type 0.635.

4 In the **Height** text field, type l_{pin} .

5 Locate the **Position** section. In the **x** text field, type r_{helix} .

6 In the **z** text field, type $-l_{\text{pin}}$.

Add a sphere for the solder ball.

Sphere 1 (sph1)

1 In the **Geometry** toolbar, click  **Sphere**.

2 In the **Settings** window for **Sphere**, locate the **Size** section.

3 In the **Radius** text field, type 3.6.

4 Locate the **Position** section. In the **x** text field, type r_{helix} .

5 In the **z** text field, type 1.5.

6 Click  **Build Selected**.

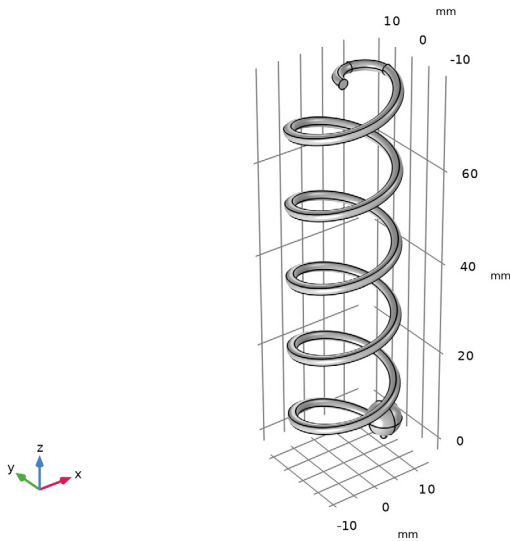

Generate the other arm of the helix by rotating the first arm.

Rotate 1 (rot1)

- 1 In the **Geometry** toolbar, click  **Transforms** and choose **Rotate**.
- 2 Click in the **Graphics** window and then press Ctrl+A to select all objects.
- 3 In the **Settings** window for **Rotate**, locate the **Input** section.
- 4 Select the **Keep input objects** checkbox.
- 5 Locate the **Rotation** section. In the **Angle** text field, type 180.

Create a union of all geometries to remove unnecessary interior boundaries.

Union 1 (un1)

- 1 In the **Geometry** toolbar, click  **Booleans and Partitions** and choose **Union**.
- 2 Click in the **Graphics** window and then press Ctrl+A to select all objects.
- 3 In the **Settings** window for **Union**, locate the **Union** section.
- 4 Clear the **Keep interior boundaries** checkbox.

5 Click  **Build Selected**.

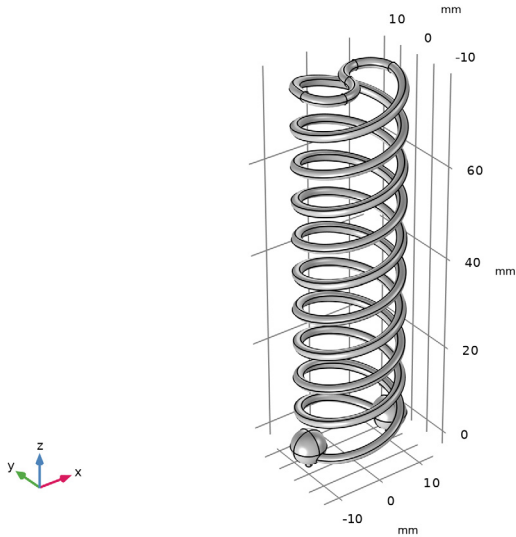

Add a cylinder for the coaxial cable inner conductor.

Cylinder 2 (cyl2)

- 1 In the **Geometry** toolbar, click  **Cylinder**.
- 2 In the **Settings** window for **Cylinder**, locate the **Size and Shape** section.
- 3 In the **Radius** text field, type 0.635.
- 4 In the **Height** text field, type h_{ground} .
- 5 Locate the **Position** section. In the **x** text field, type r_{helix} .
- 6 In the **z** text field, type $-h_{\text{ground}}-1_{\text{pin}}$.

Add a cylinder for the coaxial cable outer conductor.

Cylinder 3 (cyl3)

- 1 In the **Geometry** toolbar, click  **Cylinder**.
- 2 In the **Settings** window for **Cylinder**, locate the **Size and Shape** section.
- 3 In the **Radius** text field, type 2.05.
- 4 In the **Height** text field, type h_{ground} .
- 5 Locate the **Position** section. In the **x** text field, type r_{helix} .
- 6 In the **z** text field, type $-h_{\text{ground}}-1_{\text{pin}}$.

Add a cylinder for the impedance matching stub.

Cylinder 4 (cyl4)

- 1 In the **Geometry** toolbar, click  **Cylinder**.
- 2 In the **Settings** window for **Cylinder**, locate the **Size and Shape** section.
- 3 In the **Radius** text field, type 8.
- 4 In the **Height** text field, type 15.
- 5 Locate the **Position** section. In the **z** text field, type -1_pin.



Block 1 (blk1)

- 1 In the **Geometry** toolbar, click  **Block**.
- 2 In the **Settings** window for **Block**, locate the **Size and Shape** section.
- 3 In the **Width** text field, type 14.
- 4 In the **Depth** text field, type 14.
- 5 In the **Height** text field, type 10.
- 6 Locate the **Position** section. In the **x** text field, type 6.
- 7 In the **y** text field, type -7.
- 8 In the **z** text field, type -1_pin.

Mirror 1 (mir1)

- 1 In the **Geometry** toolbar, click  **Transforms** and choose **Mirror**.
- 2 Select the object **blk1** only.
- 3 In the **Settings** window for **Mirror**, locate the **Input** section.
- 4 Select the **Keep input objects** checkbox.
- 5 Locate the **Normal Vector to Plane of Reflection** section. In the **x** text field, type 1.
- 6 In the **z** text field, type 0.

Difference 1 (dif1)

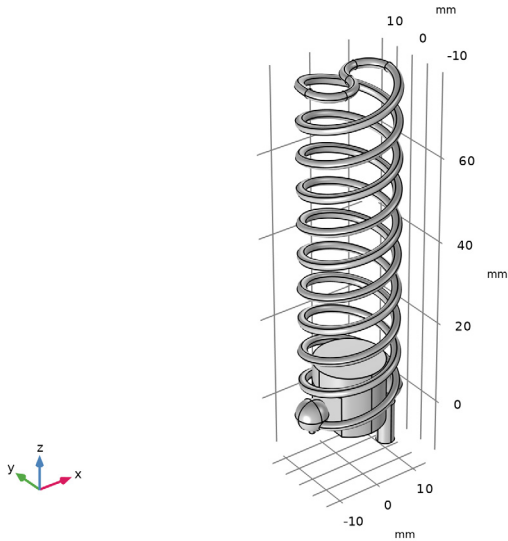

- 1 In the **Geometry** toolbar, click  **Booleans and Partitions** and choose **Difference**.
- 2 Select the object **cyl4** only.
- 3 In the **Settings** window for **Difference**, locate the **Difference** section.
- 4 Click to select the  **Activate Selection** toggle button for **Objects to subtract**.
- 5 Select the objects **blk1** and **mir1** only.

6 Click  **Build Selected**.



Add a cylinder for the ground plate.

Cylinder 5 (cyl5)

- 1 In the **Geometry** toolbar, click  **Cylinder**.
- 2 In the **Settings** window for **Cylinder**, locate the **Size and Shape** section.
- 3 In the **Radius** text field, type $50+1da0/4$.
- 4 In the **Height** text field, type h_ground .
- 5 Locate the **Position** section. In the **z** text field, type $-h_ground-1_pin$.
- 6 Click  **Build Selected**.
- 7 Click the  **Zoom Extents** button in the **Graphics** toolbar.

Choose wireframe rendering to see the interior of the antenna structure.

- 8 Click the  **Wireframe Rendering** button in the **Graphics** toolbar.

Add a sphere with a layer definition for the PML.

Sphere 2 (sph2)

- 1 In the **Geometry** toolbar, click  **Sphere**.
- 2 In the **Settings** window for **Sphere**, locate the **Definition** section.
- 3 From the **Defined by** list, choose **Bounding ball (approximate)**.
- 4 From the **Center** list, choose **Manual**.

- 5 Select the objects **cy15** and **uni1** only.
- 6 Locate the **Margin** section. In the **Margin** text field, type $1da0/4+1da0/8$.
- 7 Locate the **Position** section. In the **x** text field, type 0.
- 8 In the **y** text field, type 0.
- 9 In the **z** text field, type 30.
- 10 Click to expand the **Layers** section. In the table, enter the following settings:

Layer name	Thickness (mm)
Layer 1	1da0/8

Disable the analysis of the geometry as the remaining small geometric details can be kept.

- 11 In the **Model Builder** window, click **Geometry I**.
- 12 In the **Settings** window for **Geometry**, locate the **Cleanup** section.
- 13 Clear the **Automatic detection of small details** checkbox.
- 14 Right-click **Geometry I** and choose **Build All Objects**.

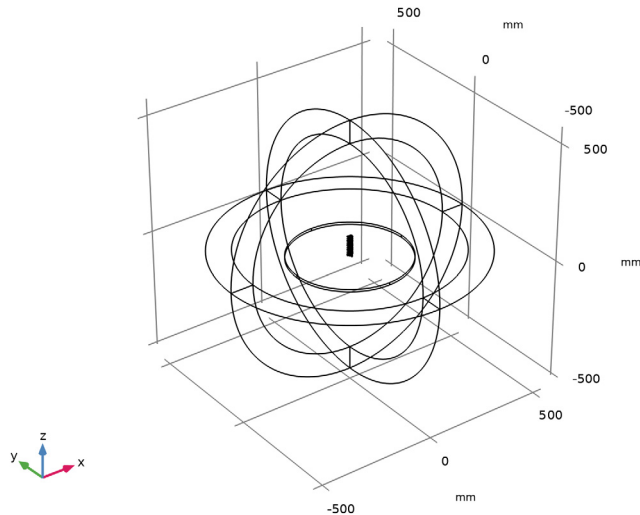

DEFINITIONS

Create a set of selections to use when setting up the physics. First, create a selection for all metal domains.

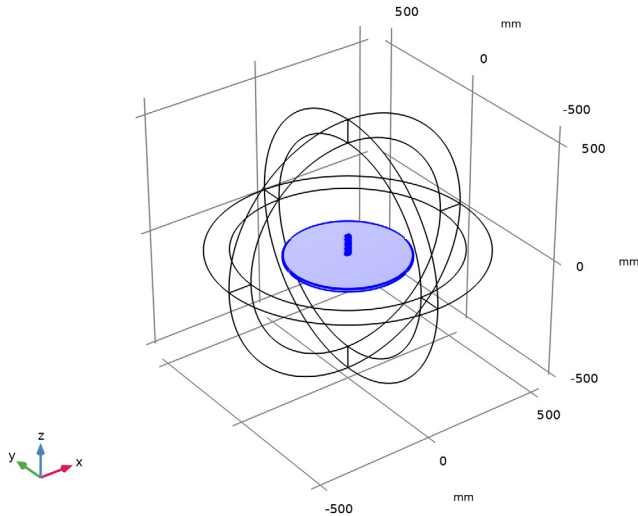

Metal

- 1 In the **Definitions** toolbar, click  **Explicit**.
- 2 In the **Settings** window for **Explicit**, type Metal in the **Label** text field.
- 3 Select Domains 6–8 and 14 only.



Add a selection for the lumped port boundary of the coaxial cable.

Port boundary

- 1 In the **Definitions** toolbar, click  **Explicit**.
- 2 In the **Settings** window for **Explicit**, type Port boundary in the **Label** text field.
- 3 Locate the **Input Entities** section. From the **Geometric entity level** list, choose **Boundary**.
- 4 Click the  **Zoom In** button in the **Graphics** toolbar, multiple times until you can see the coaxial feed part clearly.

5 Select Boundary 84 only.

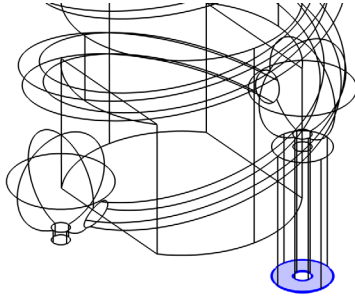

Add a selection for the dielectric in the coaxial cable.

Coax dielectric



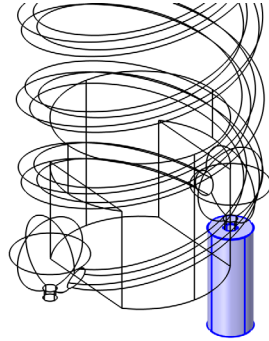

- 1 In the **Definitions** toolbar, click  **Explicit**.
- 2 In the **Settings** window for **Explicit**, type Coax dielectric in the **Label** text field.

3 Select Domain 13 only.



Add a selection for the model analysis domain, which is the complement of the Metal selection. So, the inside of the metal structure is not part of the model space.

Model domain

- 1 In the **Definitions** toolbar, click  **Complement**.
- 2 In the **Settings** window for **Complement**, type Model domain in the **Label** text field.
- 3 Locate the **Input Entities** section. Under **Selections to invert**, click  **Add**.
- 4 In the **Add** dialog, select **Metal** in the **Selections to invert** list.
- 5 Click **OK**.
- 6 Click the  **Zoom Extents** button in the **Graphics** toolbar.
- 7 Click the  **Zoom In** button in the **Graphics** toolbar.

Add a perfectly matched layer. Use the PML selection to specify the domain.

Perfectly Matched Layer 1 (pml1)

- 1 In the **Definitions** toolbar, click  **Perfectly Matched Layer**.

2 Select Domains 1–4 and 9–12 only.

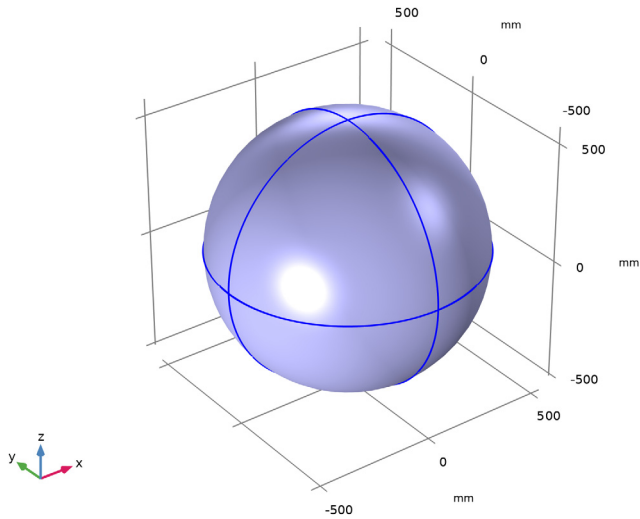

3 In the **Settings** window for **Perfectly Matched Layer**, locate the **Geometry** section.

4 From the **Type** list, choose **Spherical**.

View 1

Suppress some domains and boundaries to get a better view of the interior parts when setting up the physics and reviewing the mesh.

Hide for Physics 1

1 In the **Model Builder** window, right-click **View 1** and choose **Hide for Physics**.

2 Select Domains 1, 2, 9, and 10 only.

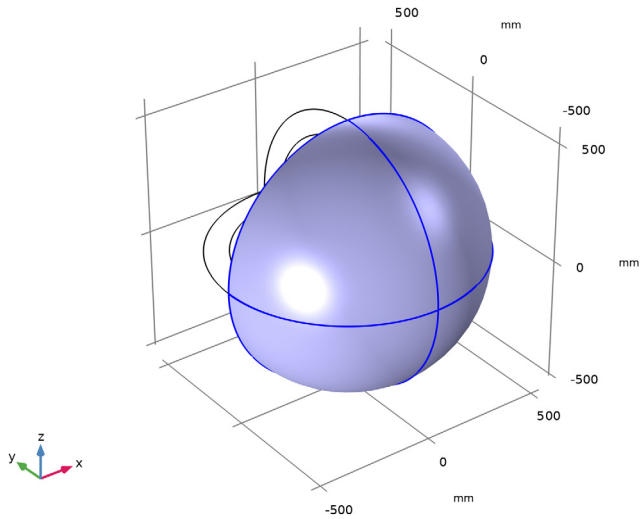

Hide for Physics 2

- 1 Right-click **View 1** and choose **Hide for Physics**.
- 2 In the **Settings** window for **Hide for Physics**, locate the **Geometric Entity Selection** section.
- 3 From the **Geometric entity level** list, choose **Boundary**.

4 Select Boundaries 9, 10, 55, and 56 only.

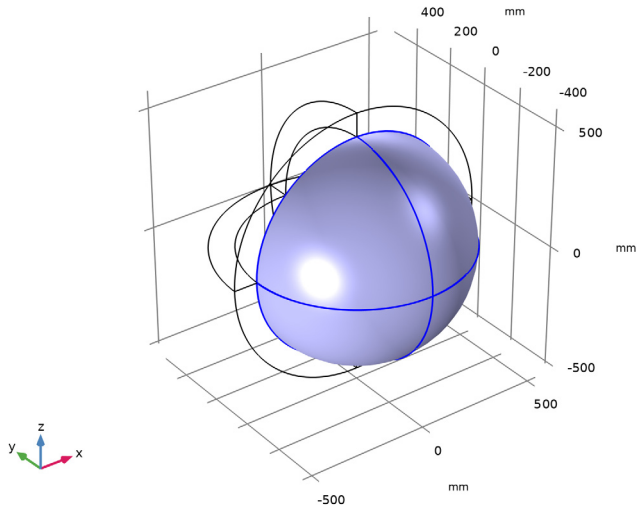

ELECTROMAGNETIC WAVES, FREQUENCY DOMAIN (EMW)

Set up the physics. Use the selections already defined when specifying domains and boundaries.

- 1 In the **Model Builder** window, under **Component 1 (comp1)** click **Electromagnetic Waves, Frequency Domain (emw)**.
- 2 In the **Settings** window for **Electromagnetic Waves, Frequency Domain**, locate the **Domain Selection** section.
- 3 From the **Selection** list, choose **Model domain**.

Far-Field Domain 1

In the **Physics** toolbar, click  **Domains** and choose **Far-Field Domain**.

Lumped Port 1



- 1 In the **Physics** toolbar, click  **Boundaries** and choose **Lumped Port**.
- 2 In the **Settings** window for **Lumped Port**, locate the **Boundary Selection** section.
- 3 From the **Selection** list, choose **Port boundary**.
- 4 Locate the **Lumped Port Properties** section. From the **Type of lumped port** list, choose **Coaxial**.

For the first port, wave excitation is **on** by default.

MATERIALS

Assign material properties. Use air for all domains. Then, override the dielectric in the coaxial cable with PTFE.

ADD MATERIAL

- 1 In the **Materials** toolbar, click  **Add Material** to open the **Add Material** window.
- 2 Go to the **Add Material** window.
- 3 In the tree, select **Built-in > Air**.
- 4 Click the **Add to Component** button in the window toolbar.
- 5 In the **Materials** toolbar, click  **Add Material** to close the **Add Material** window.

MATERIALS

PTFE

- 1 In the **Model Builder** window, under **Component 1 (comp1)** right-click **Materials** and choose **Blank Material**.
- 2 In the **Settings** window for **Material**, type PTFE in the **Label** text field.
- 3 Locate the **Geometric Entity Selection** section. From the **Selection** list, choose **Coax dielectric**.
- 4 Locate the **Material Contents** section. In the table, enter the following settings:

Property	Variable	Value	Unit	Property group
Relative permittivity	epsilon _{nr_iso} ; epsilon _{nrii} = epsilon _{nr_iso} , epsilon _{nrij} = 0	2.1		Basic
Relative permeability	mu _{r_iso} ; mu _{rii} = mu _{r_iso} , mu _{rij} = 0	1		Basic
Electric conductivity	sigma _{iso} ; sigma _{ii} = sigma _{iso} , sigma _{ij} = 0	0	S/m	Basic

MESH 1

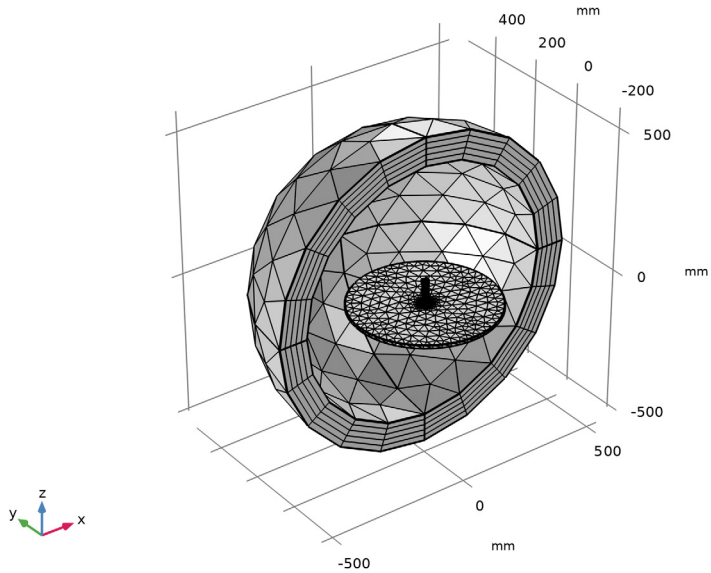

- 1 In the **Model Builder** window, under **Component 1 (comp1)** click **Mesh 1**.
- 2 In the **Settings** window for **Mesh**, locate the **Physics-Controlled Mesh** section.

- 3 In the table, select the **Use** checkbox for **Geometric Analysis, Detail Size**.
- 4 From the **Element size** list, choose **Coarse**.
- 5 Click  **Build All**.



STUDY I

Parametric Sweep

- 1 In the **Study** toolbar, click  **Parametric Sweep**.
- 2 In the **Settings** window for **Parametric Sweep**, locate the **Study Settings** section.
- 3 Click  **Add**.
- 4 In the table, enter the following settings:



Parameter name	Parameter value list	Parameter unit
f0 (Frequency in sweep)	f_normal f_axial	Hz

- 5 In the **Study** toolbar, click  **Compute**.

RESULTS

The default plot shows the E-field norm, 2D Far-field polar plot, and 3D Far-field radiation pattern.

Multislice 1

- 1 In the **Model Builder** window, expand the **Results > Electric Field (emw)** node, then click **Multislice 1**.
- 2 In the **Settings** window for **Multislice**, locate the **Expression** section.
- 3 In the **Expression** text field, type $\log_{10}(\text{emw}.\text{normE})$.
- 4 Locate the **Multiplane Data** section. Find the **X-planes** subsection. In the **Planes** text field, type 0.
- 5 Find the **Z-planes** subsection. In the **Planes** text field, type 0.
- 6 Locate the **Coloring and Style** section. From the **Color table** list, choose **Ranitomeya**.
- 7 In the **Electric Field (emw)** toolbar, click  **Plot**.
- 8 Click the  **Zoom Extents** button in the **Graphics** toolbar.

This plot shows the log-scaled E-field norm in the zx -plane around the helical antenna operating at the axial mode; compare with [Figure 2](#).

Electric Field (emw)

- 1 In the **Model Builder** window, click **Electric Field (emw)**.
- 2 In the **Settings** window for **3D Plot Group**, locate the **Data** section.
- 3 From the **Parameter value (f0 (Hz))** list, choose **3.85E8**.
- 4 In the **Electric Field (emw)** toolbar, click  **Plot**.

The log-scaled E-field norm at the normal mode is shown in [Figure 3](#).

Electric Field, Logarithmic (emw)

- 1 Click the  **Zoom Extents** button in the **Graphics** toolbar.

The default view of this plot has been generated for the longer wavelength at the normal mode, so zoom in when inspecting the axial mode plot.

2 In the **Model Builder** window, click **Electric Field, Logarithmic (emw)**.

f0(2)=4.7713E9 Hz freq(1)=4.7713 GHz Surface: 1 (1) Multislice: Electric field norm (V/m) Surface: Electric field norm (V/m)

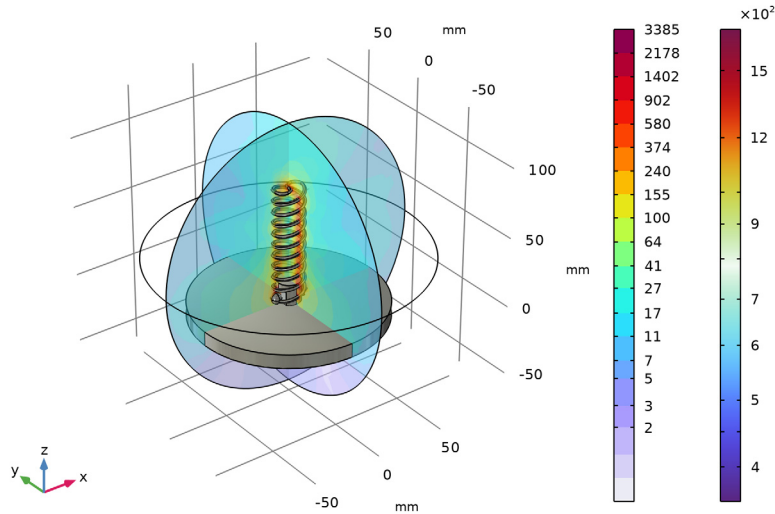

Radiation Pattern I

Apply a finer angular resolution to get a better plot of the radiation pattern.

- 1 In the **Model Builder** window, expand the **Results > 2D Far Field (emw)** node, then click **Radiation Pattern I**.
- 2 In the **Settings** window for **Radiation Pattern**, locate the **Evaluation** section.
- 3 Find the **Normal vector** subsection. In the **x** text field, type 1.
- 4 In the **z** text field, type 0.
- 5 In the **2D Far Field (emw)** toolbar, click  **Plot**.

As shown in [Figure 4](#), the plotted pattern of the axial mode is more directive than that of the normal mode.



Radiation Pattern I

- 1 Click the  **Zoom Extents** button in the **Graphics** toolbar.

Compare the reproduced axial mode 3D far-field pattern with that shown in [Figure 5](#).

3D Far Field, Gain (emw)

- 1 In the **Model Builder** window, click **3D Far Field, Gain (emw)**.
- 2 In the **Settings** window for **3D Plot Group**, locate the **Data** section.

- 3 From the **Parameter value (f0 (Hz))** list, choose **3.85E8**.
- 4 In the **3D Far Field, Gain (emw)** toolbar, click  **Plot**.
- 5 Click the  **Zoom Extents** button in the **Graphics** toolbar.

See [Figure 6](#) for the normal mode 3D far-field pattern.

S-Parameter (emw)

The calculated S-parameters at the input port should be better than -10 dB for both modes.

3D Plot Group 8

- 1 In the **Results** toolbar, click  **3D Plot Group**.
- 2 In the **Settings** window for **3D Plot Group**, locate the **Data** section.
- 3 From the **Dataset** list, choose **Study 1/Parametric Solutions 1 (sol2)**.
- 4 Locate the **Plot Settings** section. From the **View** list, choose **New view**.

Isosurface 1

- 1 Right-click **3D Plot Group 8** and choose **Isosurface**.
- 2 In the **Settings** window for **Isosurface**, locate the **Expression** section.
- 3 In the **Expression** text field, type $20 * \log_{10}(emw.normE+1)$.
- 4 Locate the **Levels** section. In the **Total levels** text field, type 20.
- 5 Locate the **Coloring and Style** section. From the **Color table** list, choose **Tectocoris**.

Filter 1

- 1 Right-click **Isosurface 1** and choose **Filter**.
- 2 In the **3D Plot Group 8** toolbar, click  **Plot**.
- 3 In the **Model Builder** window, click **Filter 1**.
- 4 In the **Settings** window for **Filter**, locate the **Element Selection** section.
- 5 In the **Logical expression for inclusion** text field, type $y > 0$.

Selection 1

- 1 In the **Model Builder** window, right-click **Isosurface 1** and choose **Selection**.
- 2 Select Domain 5 only.

Transparency 1

- 1 Right-click **Isosurface 1** and choose **Transparency**.
- 2 In the **Settings** window for **Transparency**, locate the **Transparency** section.
- 3 Find the **Transparency** subsection. From the **Input** list, choose **Expression**.

- 4 In the **Minimum transparency** text field, type 0.8.
- 5 In the **Maximum transparency** text field, type 0.
- 6 In the **3D Plot Group 8** toolbar, click  **Plot**.

Surface 1

- 1 In the **Model Builder** window, right-click **3D Plot Group 8** and choose **Surface**.
- 2 In the **Settings** window for **Surface**, locate the **Coloring and Style** section.
- 3 From the **Color table** list, choose **Xylethrus**.

Selection 1

- 1 Right-click **Surface 1** and choose **Selection**.
- 2 In the **Settings** window for **Selection**, locate the **Selection** section.
- 3 From the **Geometric entity level** list, choose **Domain**.
- 4 From the **Selection** list, choose **Metal**.

3D Plot Group 8

- 1 In the **Model Builder** window, under **Results** click **3D Plot Group 8**.
- 2 In the **Settings** window for **3D Plot Group**, locate the **Plot Settings** section.
- 3 Clear the **Plot dataset edges** checkbox.

4 In the **3D Plot Group 8** toolbar, click  **Plot**.

$f_0(2)=4.7713E9$ Hz freq(1)=4.7713 GHz Isosurface: $20*\log_{10}(emw.normE+1)$ Surface: Electric field norm (V/m)

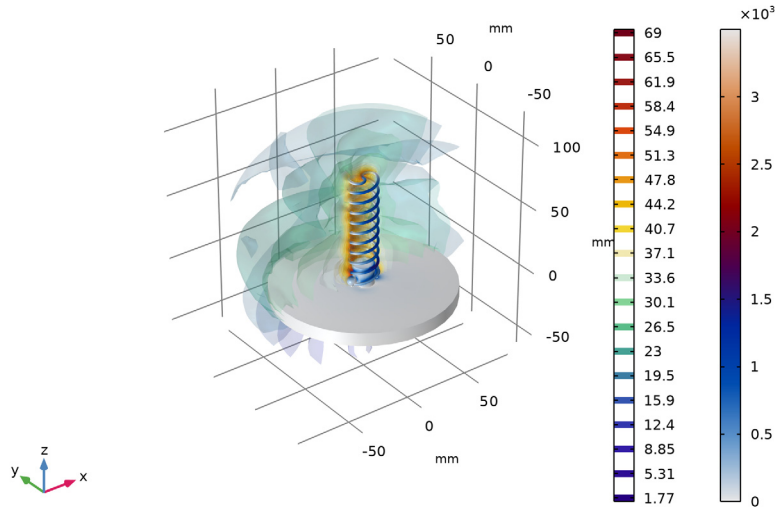

Polar Plot Group 9

- 1 In the **Results** toolbar, click  **Polar Plot Group**.
- 2 In the **Settings** window for **Polar Plot Group**, locate the **Data** section.
- 3 From the **Dataset** list, choose **Study 1/Parametric Solutions 1 (sol2)**.
- 4 From the **Parameter selection (f0)** list, choose **From list**.
- 5 In the **Parameter values (f0 (Hz))** list box, select **4.7713E9**.

Radiation Pattern 1

- 1 In the **Polar Plot Group 9** toolbar, click  **More Plots** and choose **Radiation Pattern**.
- 2 In the **Settings** window for **Radiation Pattern**, click **Replace Expression** in the upper-right corner of the **Expression** section. From the menu, choose **Component 1 (comp1) > Electromagnetic Waves, Frequency Domain > Far field > emw.axialRatiodB - Axial ratio, dB - dB**.
- 3 Locate the **Evaluation** section. Find the **Normal vector** subsection. In the **x** text field, type 1.
- 4 In the **z** text field, type 0.
- 5 Find the **Reference direction** subsection. In the **x** text field, type 0.

- 6 In the **y** text field, type 1.
- 7 Find the **Angles** subsection. In the **Number of angles** text field, type 180.
- 8 Click to expand the **Legends** section. From the **Legends** list, choose **Manual**.
- 9 Select the **Show legends** checkbox.
- 10 In the table, enter the following settings:

Legends
Axial ratio at 4.7713 GHz

- 11 Click to expand the **Coloring and Style** section. From the **Width** list, choose **2**.

Polar Plot Group 9

- 1 In the **Model Builder** window, click **Polar Plot Group 9**.
- 2 In the **Settings** window for **Polar Plot Group**, locate the **Axis** section.
- 3 Select the **Manual axis limits** checkbox.
- 4 In the **r minimum** text field, type 0.
- 5 In the **r maximum** text field, type 10.

Radiation Pattern 2

- 1 In the **Polar Plot Group 9** toolbar, click  **More Plots** and choose **Radiation Pattern**.
- 2 In the **Settings** window for **Radiation Pattern**, locate the **Expression** section.
- 3 In the **Expression** text field, type 3.
- 4 Locate the **Evaluation** section. Find the **Normal vector** subsection. In the **x** text field, type 1.
- 5 In the **z** text field, type 0.
- 6 Find the **Reference direction** subsection. In the **x** text field, type 0.
- 7 In the **y** text field, type 1.
- 8 Locate the **Legends** section. From the **Legends** list, choose **Manual**.
- 9 Select the **Show legends** checkbox.
- 10 In the table, enter the following settings:

Legends
3 dB

- 11 Locate the **Coloring and Style** section. Find the **Line style** subsection. From the **Line** list, choose **Dashed**.

- 12** From the **Color** list, choose **Red**.
- 13** From the **Width** list, choose **2**.
- 14** In the **Polar Plot Group 9** toolbar, click  **Plot**.

Polar Plot Group 9

- 1** In the **Model Builder** window, click **Polar Plot Group 9**.
- 2** In the **Settings** window for **Polar Plot Group**, click to expand the **Title** section.
- 3** From the **Title type** list, choose **Manual**.
- 4** In the **Title** text area, type Axial ratio, dB.
- 5** In the **Polar Plot Group 9** toolbar, click  **Plot**.

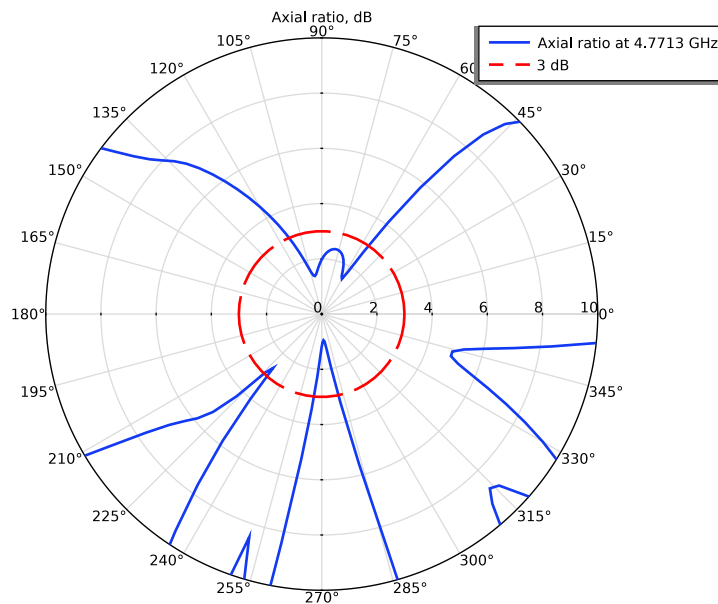

the axial ratio plot shows how much the antenna is circularly polarized. When it is characterized as the perfect circular polarization, the axial ratio is 1 or 0 dB. When it is below 3 dB (inside the red circle), it is typically regarded as a circular polarization. In the figure, the axial ratio is lower than 3 dB at the antenna boresight that is the major direction of propagation of the axial mode, parallel to the helical twist axis.