



Model created in COMSOL Multiphysics 6.4

# Modeling of a Grounded CPW Using Numeric TEM Ports

## Introduction

---

This tutorial model shows how to set up port features in a physics interface when designing a grounded coplanar waveguide (GCPW) circuit that is useful for mmWave applications.

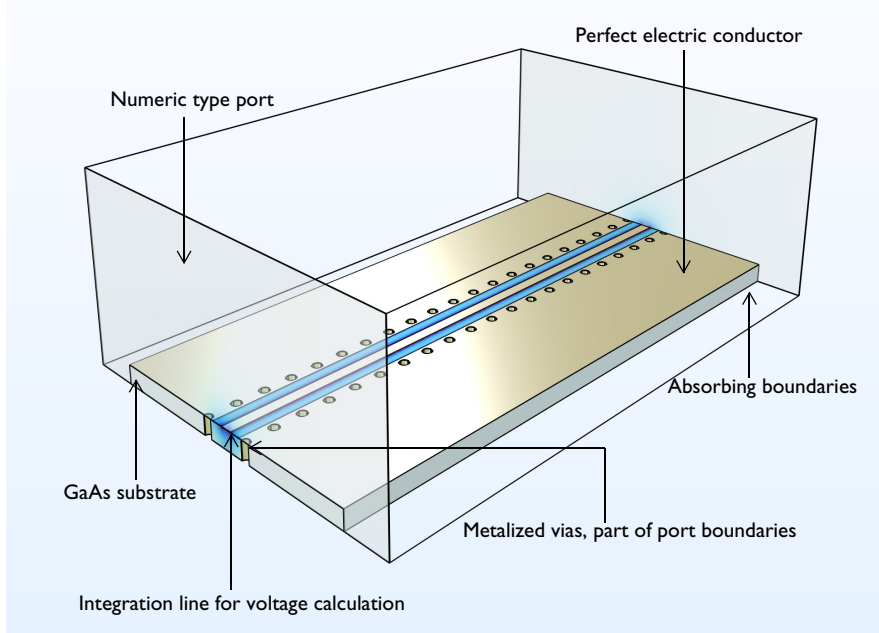

Figure 1: Grounded coplanar waveguide (GCPW) simulation model.

## Model Definition

---

Port features can be used to excite and terminate a grounded CPW. In this tutorial, a basic CPW circuit grounded by metalized vias is modeled using **Numeric** type ports with **Analyze as a TEM field** option. This configuration requires adding a **Boundary Mode Analysis** in the study and an **Integration Line for Voltage** subfeature for each port feature to calculate the TEM mode characteristic impedance. The TEM mode characteristic impedance is calculated based on the power on port boundaries and voltage obtained from the user-defined integration through the abovementioned subfeature. The computed impedance scales the mode field that is mapped to the port boundaries to excite or terminate the end cross-section of the circuit. Note that the metalized conductive edges must be included on

the numeric port boundaries to capture a proper mode propagating through the grounded CPW circuit.

TABLE I: KEY ITEMS TO CHARACTERIZE A GROUNDED COPLANAR WAVEGUIDE

	Physics feature	Subfeature	Study step
<b>Item in Model Builder</b>	Port	Integration Line for Voltage	Boundary Mode Analysis
<b>Notable configuration</b>	Numeric type Analyze as a TEM field Include via edges	Set on a line geometry between two conductive boundaries	

All conductive boundaries representing metalized or plated surfaces are defined as perfect electric conductors (PEC) to simplify the modeling steps. Since the volume of the vias are removed from the geometry and simulation domains, their surfaces are set to PEC by default. If the loss due to the finite conductivity is assumed to be nonnegligible, these boundaries can be replaced by a transition boundary condition to take the loss in the model into account.

A scattering boundary conditions is applied to the outermost boundaries. A scattering boundary condition absorbs any possible radiation from the circuit and mimics an open space.

### *Results and Discussion*

The computed S-parameters indicate that the reflection due to the impedance mismatch is marginal (below  $-30$  dB) and the insertion loss is below 0.05 dB. When the computation is completed, three defaults plots are automatically generated. From the electric field norm plot, it is possible to see where the strong electric fields are confined, along the conductive edges around slots between the center conductor and a pair of ground planes. When performing a boundary mode analysis for each port, the default mode field plot is available with an annotation of the computed impedance value. See the *Modeling Instruction* section below for details.

---

**Application Library path:** RF\_Module/Transmission\_Lines\_and\_Waveguides/gcpw\_numeric\_tem\_port



---

From the **File** menu, choose **New**.

### NEW

In the **New** window, click  **Model Wizard**.

### MODEL WIZARD

- 1 In the **Model Wizard** window, click .
- 2 In the **Select Physics** tree, select **Radio Frequency > Electromagnetic Waves, Frequency Domain (emw)**.
- 3 Click **Add**.
- 4 Click  **Study**.
- 5 In the **Select Study** tree, select **Preset Studies for Selected Physics Interfaces > Boundary Mode Analysis**.
- 6 Click  **Done**.

### STUDY I

#### *Step 1: Boundary Mode Analysis*

Define the study frequency ahead of performing any frequency-dependent operation such as building mesh. The physics-controlled mesh uses the specified frequency value.

- 1 In the **Model Builder** window, under **Study I** click **Step 1: Boundary Mode Analysis**.
- 2 In the **Settings** window for **Boundary Mode Analysis**, locate the **Study Settings** section.
- 3 In the **Mode analysis frequency** text field, type 10[GHz].
- 4 Select the **Search for modes around shift** checkbox. In the associated text field, type  $\text{sqrt}(12.9)/1.5$ .

#### *Step 3: Boundary Mode Analysis I*

- 1 Right-click **Study I > Step 1: Boundary Mode Analysis** and choose **Duplicate**.
- 2 Drag and drop **Step 3: Boundary Mode Analysis I** below **Step 1: Boundary Mode Analysis**.
- 3 In the **Settings** window for **Boundary Mode Analysis**, locate the **Study Settings** section.
- 4 In the **Port name** text field, type 2.



#### *Step 3: Frequency Domain*

- 1 In the **Model Builder** window, click **Step 3: Frequency Domain**.
- 2 In the **Settings** window for **Frequency Domain**, locate the **Study Settings** section.

3 In the **Frequencies** text field, type 10[GHz].

### GEOMETRY I

The basic model geometry is available as a parameterized geometry sequence in a separate MPH file. If you want to build it from scratch, follow the instructions in the section [Appendix: Geometry Modeling Instructions](#). Otherwise load it from file with the following steps.

- 1 In the **Geometry** toolbar, click **Insert Sequence** and choose **Insert Sequence**.
- 2 Browse to the model's Application Libraries folder and double-click the file `gcpw_geom_sequence.mph`.
- 3 In the **Geometry** toolbar, click  **Build All**.
- 4 Click the  **Zoom Extents** button in the **Graphics** toolbar.
- 5 Click the  **Wireframe Rendering** button in the **Graphics** toolbar.
- 6 In the **Model Builder** window, under **Component 1 (comp1)** click **Geometry I**.

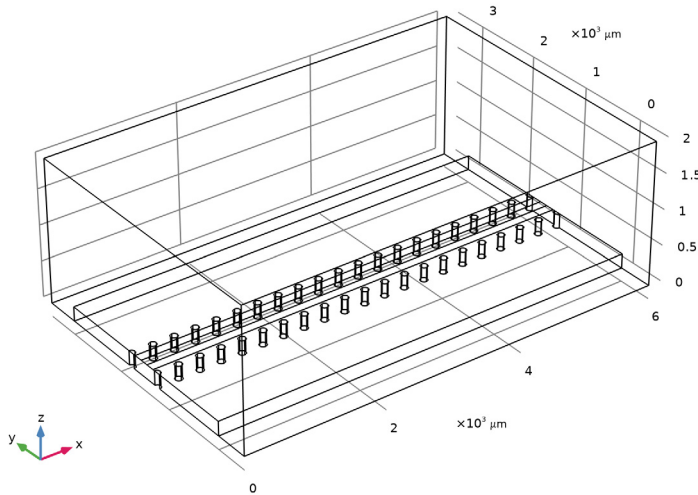

### MATERIALS

*Material 1 (mat1)*

- 1 In the **Model Builder** window, under **Component 1 (comp1)** right-click **Materials** and choose **Blank Material**.
- 2 In the **Settings** window for **Material**, locate the **Material Contents** section.

3 In the table, enter the following settings:

Property	Variable	Value	Unit	Property group
Relative permittivity	epsilon <sub>nr_</sub> iso ; epsilon <sub>nrii</sub> = epsilon <sub>nr_</sub> iso, epsilon <sub>nrij</sub> = 0	1		Basic
Relative permeability	mu <sub>r_</sub> iso ; mu <sub>rii</sub> = mu <sub>r_</sub> iso, mu <sub>rij</sub> = 0	1		Basic
Electric conductivity	sigma <sub>iso</sub> ; sigma <sub>ii</sub> = sigma <sub>iso</sub> , sigma <sub>ij</sub> = 0	0	S/m	Basic

Material 2 (mat2)

1 Right-click **Materials** and choose **Blank Material**.

2 Select Domain 2 only.

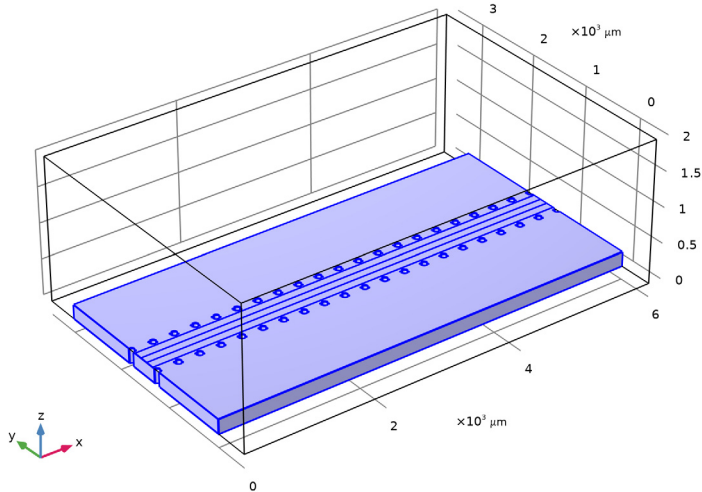

3 In the **Settings** window for **Material**, locate the **Material Contents** section.

4 In the table, enter the following settings:

Property	Variable	Value	Unit	Property group
Relative permittivity	epsilon <sub>nr_</sub> iso ; epsilon <sub>nrii</sub> = epsilon <sub>nr_</sub> iso, epsilon <sub>nrij</sub> = 0	12.9		Basic
Relative permeability	mu <sub>r_</sub> iso ; mu <sub>rii</sub> = mu <sub>r_</sub> iso, mu <sub>rij</sub> = 0	1		Basic
Electric conductivity	sigma <sub>iso</sub> ; sigma <sub>ii</sub> = sigma <sub>iso</sub> , sigma <sub>ij</sub> = 0	0	S/m	Basic

## ELECTROMAGNETIC WAVES, FREQUENCY DOMAIN (EMW)

### Perfect Electric Conductor 2

1 In the **Physics** toolbar, click  **Boundaries** and choose **Perfect Electric Conductor**.

2 Select Boundaries 8, 14, and 16 only.

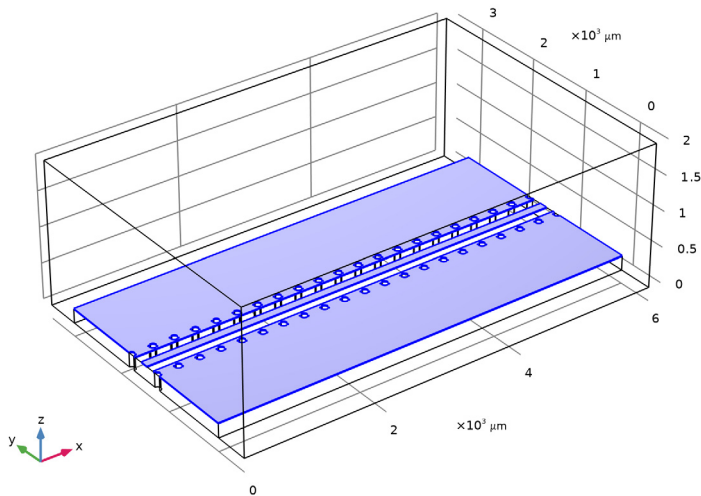

### Scattering Boundary Condition 1

1 In the **Physics** toolbar, click  **Boundaries** and choose **Scattering Boundary Condition**.

2 Select Boundaries 2–4, 22, and 23 only.

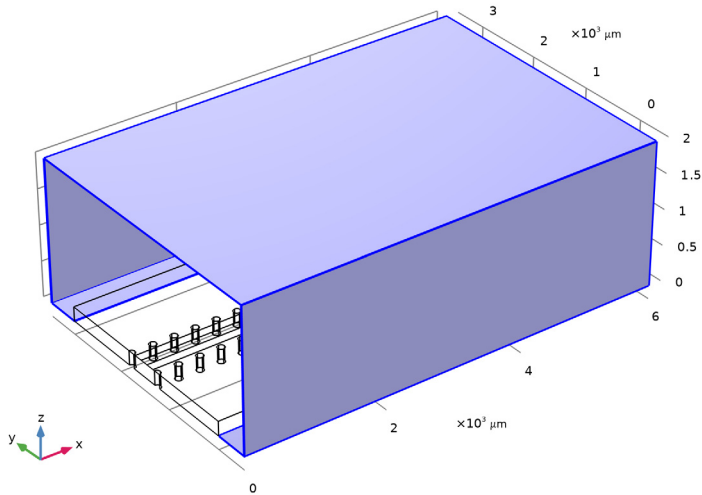

*Port 1*

1 In the **Physics** toolbar, click  **Boundaries** and choose **Port**.

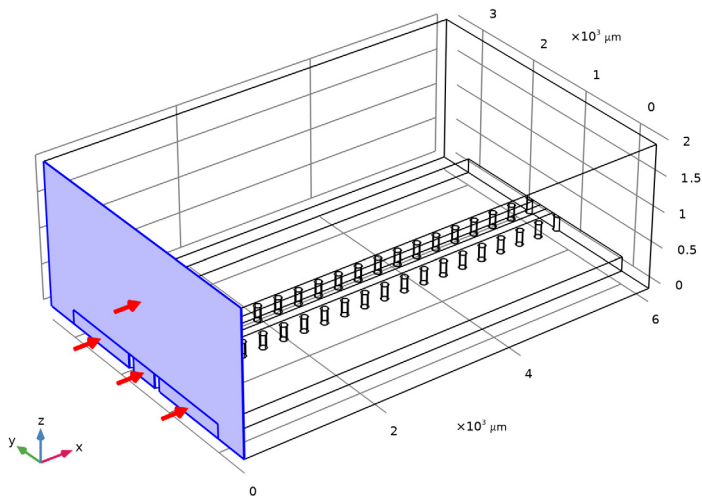

2 Select Boundaries 1, 5, 11, and 19 only.



3 In the **Settings** window for **Port**, locate the **Port Properties** section.

- 4 From the **Type of port** list, choose **Numeric**.
- 5 Select the **Analyze as a TEM field** checkbox.

*Integration Line for Voltage 1*

- 1 In the **Physics** toolbar, click  **Attributes** and choose **Integration Line for Voltage**.
- 2 In the **Settings** window for **Integration Line for Voltage**, locate the **Edge Selection** section.
- 3 Click  **Clear Selection**.
- 4 Select Edge 20 only.
- 5 Locate the **Settings** section. Click **Toggle Voltage Drop Direction**.

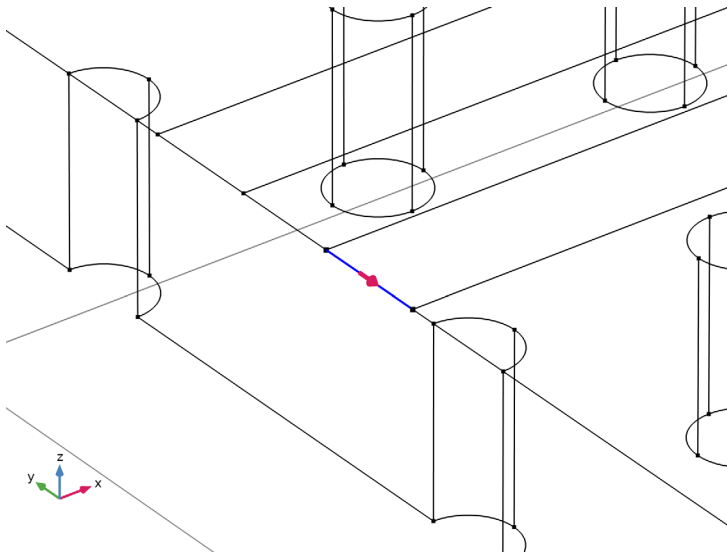

*Port 2*

- 1 In the **Physics** toolbar, click  **Boundaries** and choose **Port**.

2 Select Boundaries 220–223 only.

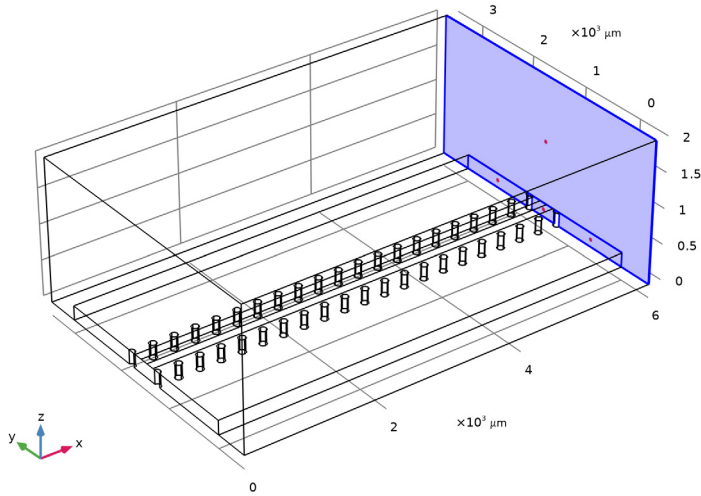

3 In the **Settings** window for **Port**, locate the **Port Properties** section.

4 From the **Type of port** list, choose **Numeric**.

5 Select the **Analyze as a TEM field** checkbox.

#### *Integration Line for Voltage I*

1 In the **Physics** toolbar, click  **Attributes** and choose **Integration Line for Voltage**.

2 In the **Settings** window for **Integration Line for Voltage**, locate the **Edge Selection** section.

3 Click  **Clear Selection**.

4 Select Edge 523 only.

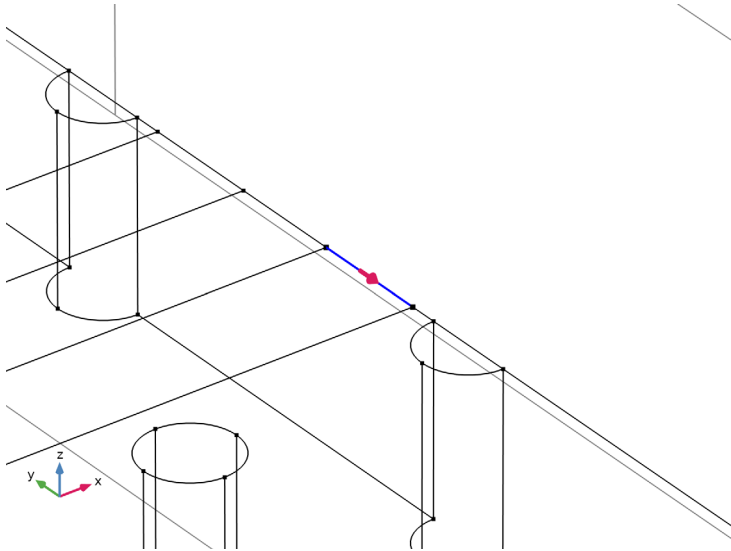



#### **MESH 1**

- 1 In the **Model Builder** window, under **Component 1 (comp1)** click **Mesh 1**.
- 2 In the **Settings** window for **Mesh**, locate the **Physics-Controlled Mesh** section.
- 3 From the **Element size** list, choose **Coarse**.

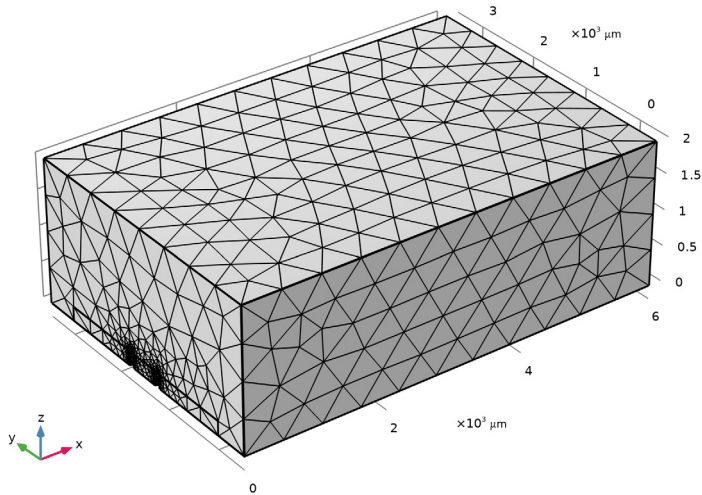
4 Click  **Build All**.



5 In the **Graphics** window toolbar, click ▼ next to  **Select Edges**, then choose **Select Boundaries**.

6 Click the  **Click and Hide** button in the **Graphics** toolbar.

7 Select Boundaries 2 and 4 only.

8 Click the  **Click and Hide** button in the **Graphics** toolbar.

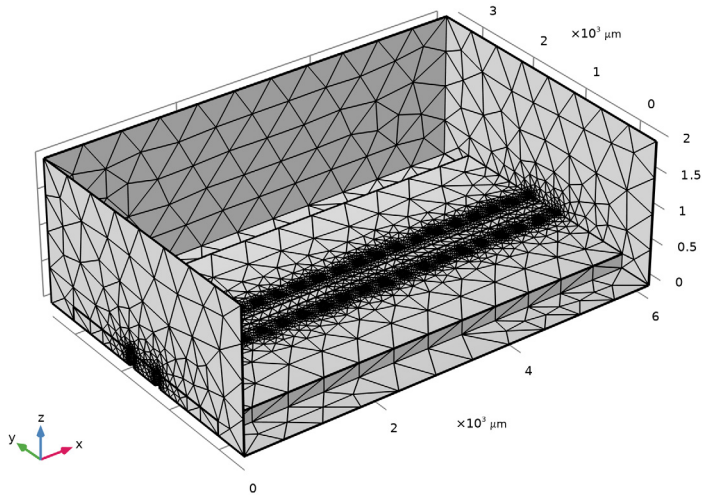

9 Locate the **Electromagnetic Waves, Frequency Domain (emw)** section. Select the **Refine conductive edges** checkbox.

10 In the **Relative size to default mesh** text field, type  $0.02/\text{sqrt}(12.9)$ .

11 Click  **Build All**.

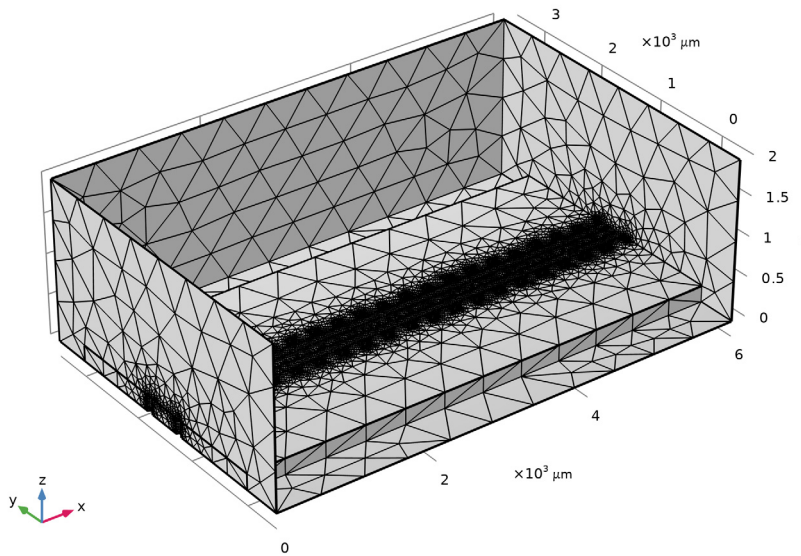

12 In the **Home** toolbar, click  **Compute**.

## RESULTS

### *Multislice 1*

- 1 In the **Model Builder** window, expand the **Electric Field (emw)** node, then click **Multislice 1**.
- 2 In the **Settings** window for **Multislice**, locate the **Multipane Data** section.
- 3 Find the **X-planes** subsection. In the **Planes** text field, type 0.
- 4 Find the **Y-planes** subsection. In the **Planes** text field, type 0.
- 5 Find the **Z-planes** subsection. From the **Entry method** list, choose **Coordinates**.
- 6 In the **Coordinates** text field, type 200.

7 Locate the **Coloring and Style** section. From the **Color table** list, choose **HeatCameraLight**.

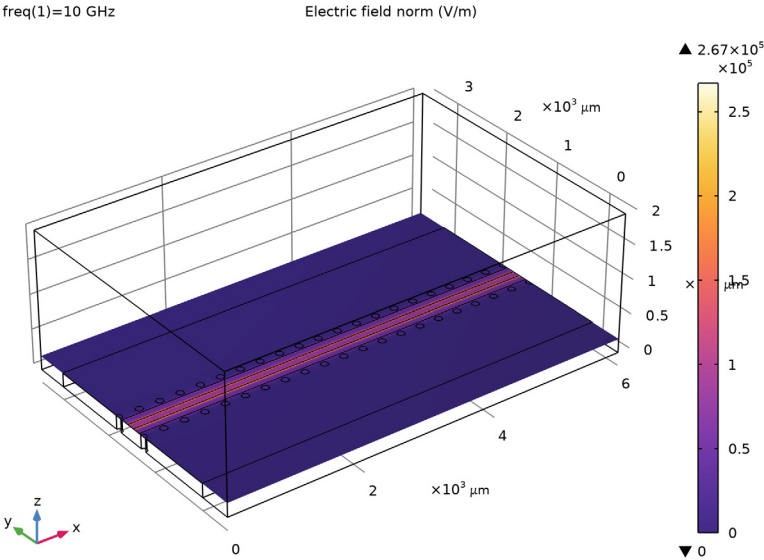

*Electric Field, Logarithmic (emw)*

In the **Model Builder** window, under **Results** click **Electric Field, Logarithmic (emw)**.

freq(1)=10 GHz Surface: 1 (1) Surface: 1 (1) Surface: Electric field norm (V/m) Surface: Electric field norm (V/m)

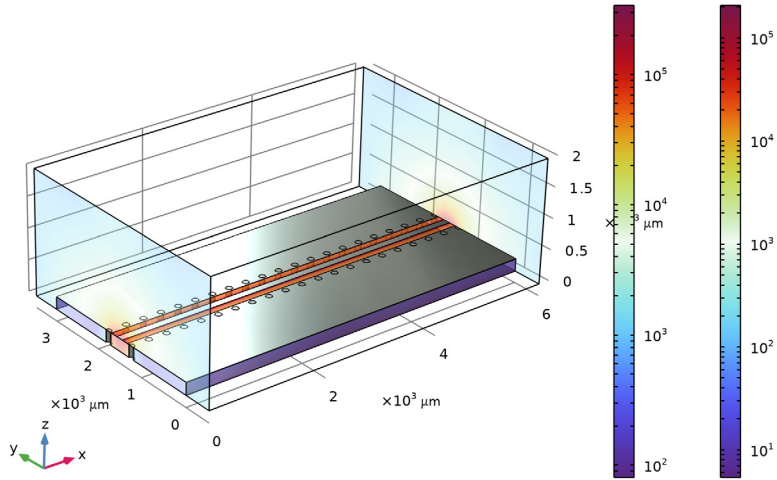

Inspect the mode field and the computed TEM mode impedance in the default plot.

*Electric Mode Field, Port 1 (emw)*

In the **Model Builder** window, click **Electric Mode Field, Port 1 (emw)**.

freq(1)=10 GHz

Tangential boundary mode electric field norm (V/m)

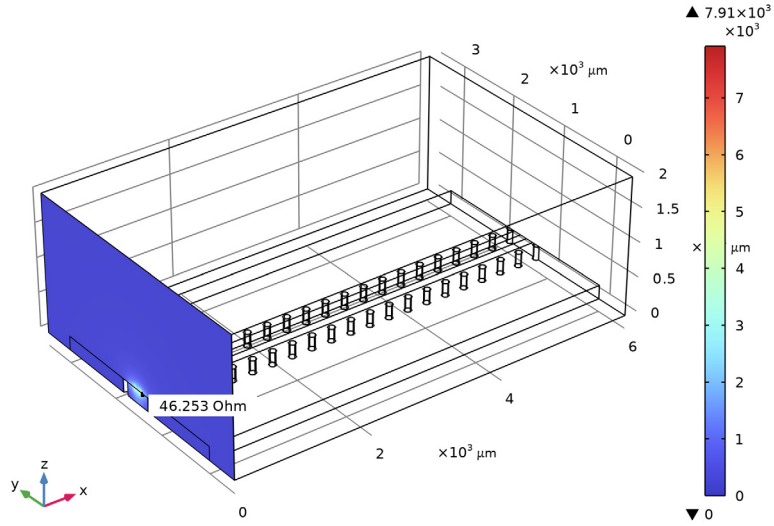

*Electric Mode Field, Port 2 (emw)*

In the **Model Builder** window, click **Electric Mode Field, Port 2 (emw)**.

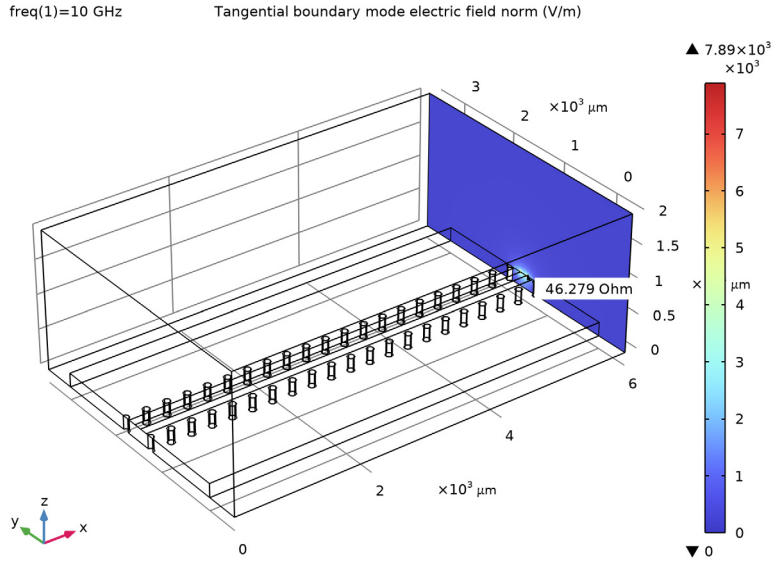

*Appendix: Geometry Modeling Instructions*

**ADD COMPONENT**

In the **Home** toolbar, click  **Add Component** and choose **3D**.

**GLOBAL DEFINITIONS**

*Parameters 1*

**1** In the **Model Builder** window, under **Global Definitions** click **Parameters 1**.

**2** In the **Settings** window for **Parameters**, locate the **Parameters** section.

**3** In the table, enter the following settings:

Name	Expression	Value	Description
w_c	120[um]	1.2E-4 m	CPW, center conductor width
w_s	w_c+2*125[um]	3.7E-4 m	CPW, center conductor and slot width
thickness	200[um]	2E-4 m	Wafer thickness



## GEOMETRY 1

- 1 In the **Model Builder** window, under **Component 1 (comp1)** click **Geometry 1**.
- 2 In the **Settings** window for **Geometry**, locate the **Units** section.
- 3 From the **Length unit** list, choose  $\mu\text{m}$ .

### *Block 1 (blk1)*

- 1 In the **Geometry** toolbar, click  **Block**.
- 2 In the **Settings** window for **Block**, locate the **Size and Shape** section.
- 3 In the **Width** text field, type 6000.
- 4 In the **Depth** text field, type 4000.
- 5 In the **Height** text field, type 2000.
- 6 Locate the **Position** section. In the **y** text field, type -500.

### *Block 2 (blk2)*

- 1 In the **Geometry** toolbar, click  **Block**.
- 2 In the **Settings** window for **Block**, locate the **Size and Shape** section.
- 3 In the **Width** text field, type 6000.
- 4 In the **Depth** text field, type 3000.
- 5 In the **Height** text field, type thickness.
- 6 Click  **Build Selected**.

7 Click the  **Wireframe Rendering** button in the **Graphics** toolbar.

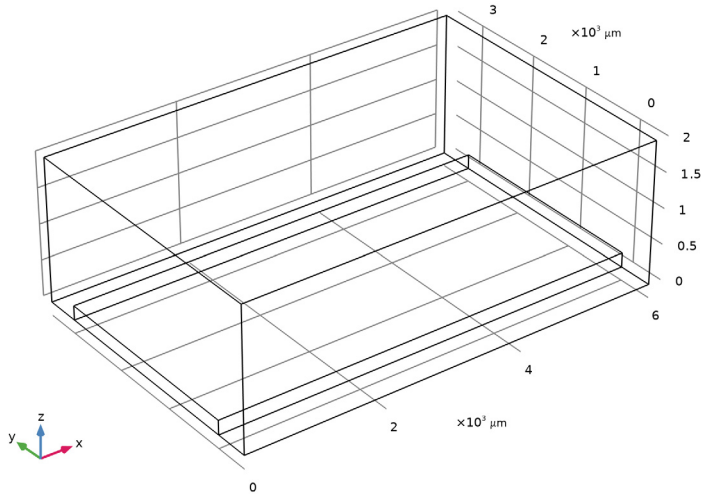

*Work Plane 1 (wp1)*

- 1 In the **Geometry** toolbar, click  **Work Plane**.
- 2 In the **Settings** window for **Work Plane**, locate the **Plane Definition** section.
- 3 From the **Plane type** list, choose **Face parallel**.
- 4 On the object **blk2**, select Boundary 4 only.

*Work Plane 1 (wp1) > Plane Geometry*

In the **Model Builder** window, click **Plane Geometry**.

*Work Plane 1 (wp1) > Rectangle 1 (r1)*



- 1 In the **Work Plane** toolbar, click  **Rectangle**.
- 2 In the **Settings** window for **Rectangle**, locate the **Size and Shape** section.
- 3 In the **Width** text field, type 6000.
- 4 In the **Height** text field, type  $w_c$ .
- 5 Locate the **Position** section. From the **Base** list, choose **Center**.

*Work Plane 1 (wp1) > Rectangle 2 (r2)*

- 1 Right-click **Component 1 (comp1) > Geometry 1 > Work Plane 1 (wp1) > Plane Geometry > Rectangle 1 (r1)** and choose **Duplicate**.
- 2 In the **Settings** window for **Rectangle**, locate the **Size and Shape** section.

- 3 In the **Height** text field, type  $w_s$ .
- 4 Locate the **Position** section. From the **Base** list, choose **Center**.

*Work Plane 1 (wpl) > Difference 1 (dif1)*

- 1 In the **Work Plane** toolbar, click  **Booleans and Partitions** and choose **Difference**.
- 2 Select the object **r2** only.
- 3 In the **Settings** window for **Difference**, locate the **Difference** section.
- 4 Click to select the  **Activate Selection** toggle button for **Objects to subtract**.
- 5 Select the object **r1** only.
- 6 Click  **Build Selected**.

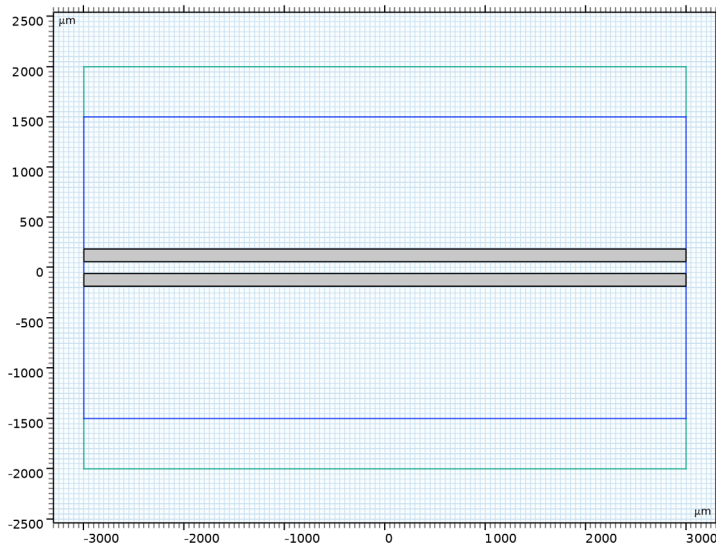



*Cylinder 1 (cyl1)*

- 1 In the **Model Builder** window, right-click **Geometry 1** and choose **Cylinder**.
- 2 In the **Settings** window for **Cylinder**, locate the **Size and Shape** section.
- 3 In the **Radius** text field, type 50.
- 4 In the **Height** text field, type 200.
- 5 Locate the **Position** section. In the **y** text field, type  $1500 - w_s / 2 - 80$ .

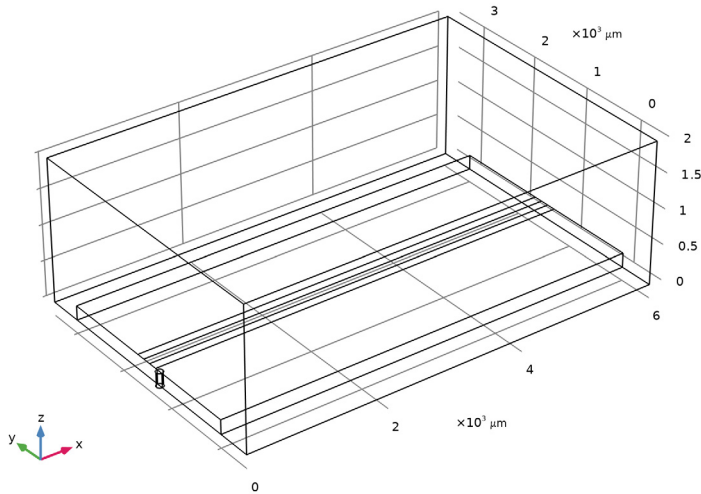
6 Click  **Build Selected.**



#### Array 1 (arr1)

- 1 In the **Geometry** toolbar, click  **Transforms** and choose **Array**.
- 2 Select the object **cyll** only.
- 3 In the **Settings** window for **Array**, locate the **Size** section.
- 4 In the **x size** text field, type 21.
- 5 Locate the **Displacement** section. In the **x** text field, type 300.
- 6 In the **y** text field, type  $w_s+80*2$ .
- 7 Locate the **Size** section. In the **y size** text field, type 2.
- 8 Locate the **Selections of Resulting Entities** section. Find the **Cumulative selection** subsection. Click **New**.
- 9 Click  **Build Selected.**

**10** In the **New Cumulative Selection** dialog, click **OK**.

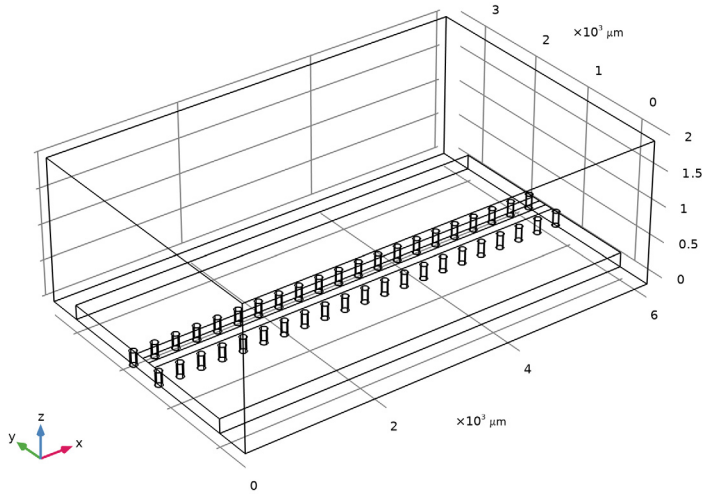

*Difference 1 (dif1)*

- 1** In the **Geometry** toolbar, click  **Booleans and Partitions** and choose **Difference**.
- 2** Select the objects **blk1** and **blk2** only.

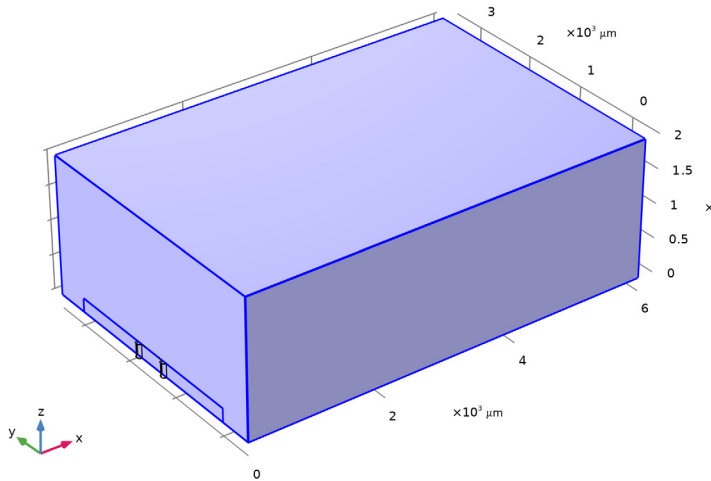

**3** In the **Settings** window for **Difference**, locate the **Difference** section.

- 4 Click to select the  **Activate Selection** toggle button for **Objects to subtract**.
- 5 From the **Objects to subtract** list, choose **Cumulative Selection I**.

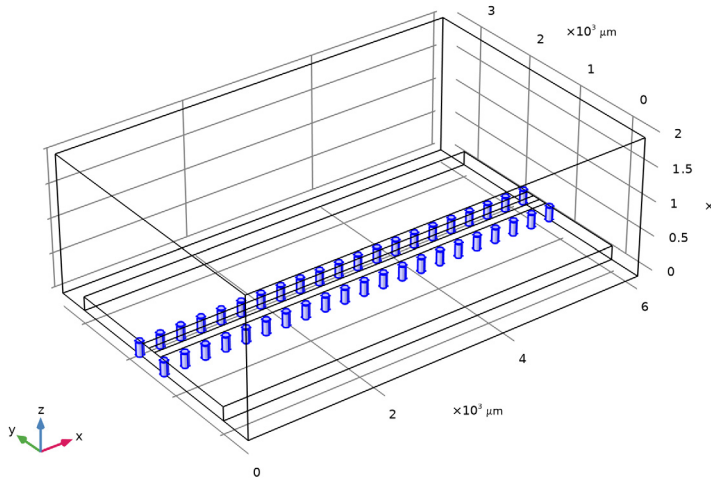

- 6 Click  **Build All Objects**.