



Model created in COMSOL Multiphysics 6.4

Fresnel Equations

Introduction

A plane electromagnetic wave propagating through free space is incident at an angle upon an infinite dielectric medium. This model computes the reflection and transmission coefficients and compares the results to the Fresnel equations.

Model Definition

A plane wave propagating through free space ($n = 1$) as shown in [Figure 1](#) is incident upon an infinite dielectric medium ($n = 1.5$) and is partially reflected and partially transmitted. If the electric field is *p-polarized* — that is, if the electric field vector is in the same plane as the Poynting vector and the surface normal — then there are no reflections at an incident angle of roughly 56° , known as the *Brewster angle*.

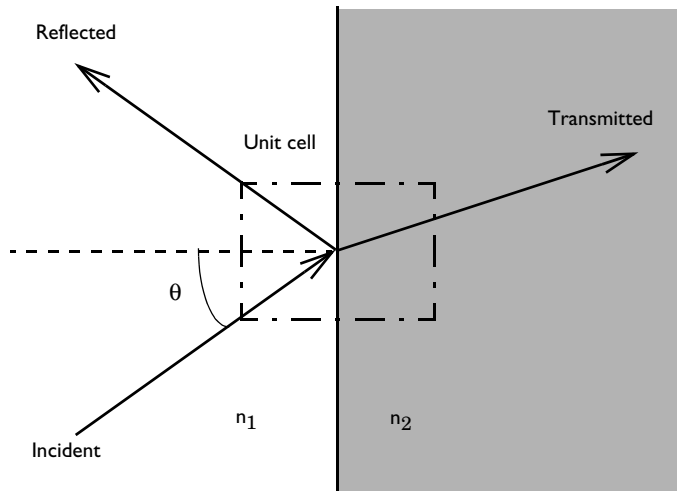

Figure 1: A plane wave propagating through free space incident upon an infinite dielectric medium.

Although, by assumption, space extends to infinity in all directions, it is sufficient to model a small unit cell, as shown in [Figure 1](#); a Floquet-periodic boundary condition applies on the top and bottom unit-cell boundaries because the solution is periodic along the interface. This model uses a 3D unit cell and applies also a periodic boundary condition in the out-of-plane direction. However, this periodic boundary condition acts like a continuity condition. The angle of incidence ranges between 0 – 90° for both polarizations.

To simplify the process of adding the boundary conditions, a Periodic Structure node is used. It automatically adds and configures its subnodes — the ports and the periodic conditions.

For comparison, [Ref. 1](#) and [Ref. 2](#) provide analytic expressions for the reflectance and transmittance¹. Reflection and transmission coefficients for s-polarization and p-polarization are defined respectively as

$$r_s = \frac{n_1 \cos \theta_{\text{incident}} - n_2 \cos \theta_{\text{transmitted}}}{n_1 \cos \theta_{\text{incident}} + n_2 \cos \theta_{\text{transmitted}}}$$

$$t_s = \frac{2n_1 \cos \theta_{\text{incident}}}{n_1 \cos \theta_{\text{incident}} + n_2 \cos \theta_{\text{transmitted}}}$$

$$r_p = \frac{n_2 \cos \theta_{\text{incident}} - n_1 \cos \theta_{\text{transmitted}}}{n_1 \cos \theta_{\text{transmitted}} + n_2 \cos \theta_{\text{incident}}}$$

$$t_p = \frac{2n_1 \cos \theta_{\text{incident}}}{n_1 \cos \theta_{\text{transmitted}} + n_2 \cos \theta_{\text{incident}}}$$

Reflectance and transmittance are defined as

$$R = |r|^2$$

$$T = \frac{n_2 \cos \theta_{\text{transmitted}}}{n_1 \cos \theta_{\text{incident}}} |t|^2$$

The Brewster angle at which $r_p = 0$ is defined as

$$\theta_B = \text{atan} \frac{n_2}{n_1}$$

1. Note that depending on the sign convention for what is defined as a positive polarization for the reflected wave with in-plane (p-polarization), the sign for the reflection coefficient r_p can differ for different authors. However, the total field solution will always be the same.

Results and Discussion

Figure 2 is a combined plot of the y component of the electric-field distribution and the power flow visualized as an arrow plot for the TE case.

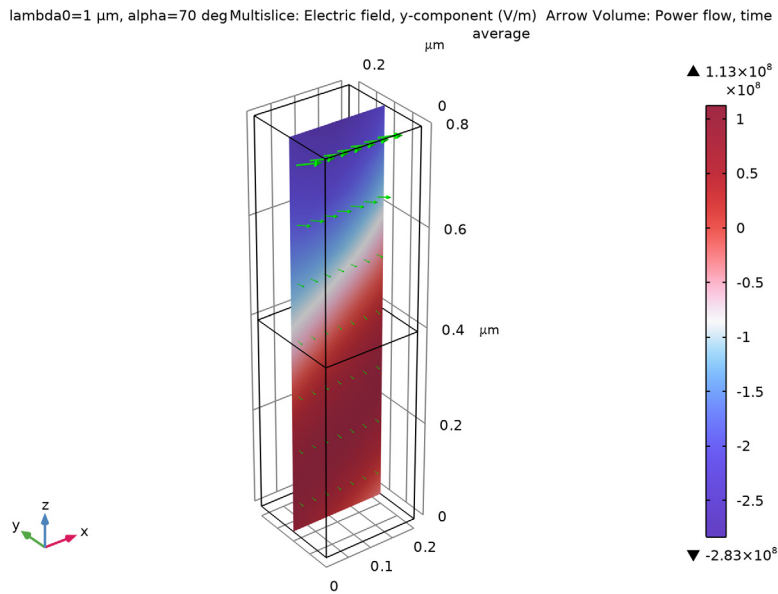

Figure 2: Electric field, E_y (slice) and power flow (arrows) for TE incidence at 70° inside the unit cell.

For the TM case, [Figure 3](#) visualizes the y component of the magnetic-field distribution instead, again in combination with the power flow.

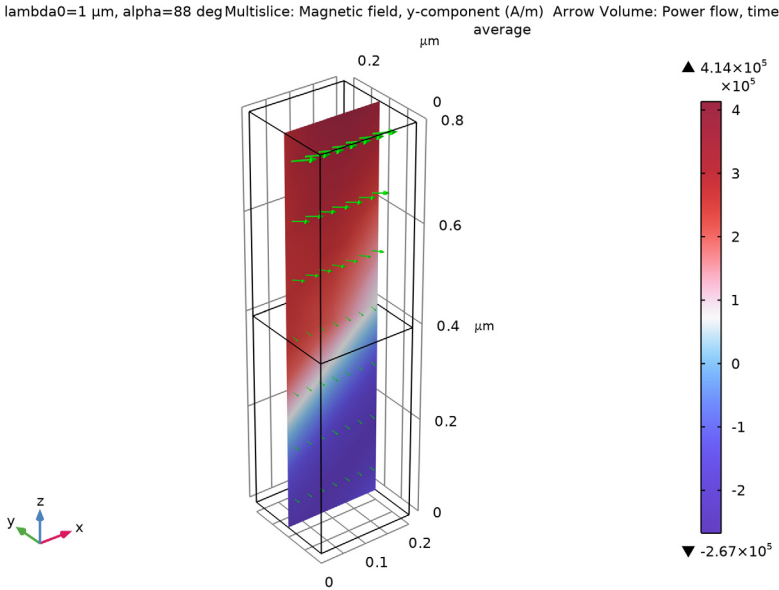

Figure 3: Magnetic field, H_y (slice) and power flow (arrows) for TM incidence at 70° inside the unit cell.

Note that the sum of reflectance and transmittance in [Figure 4](#) and [Figure 5](#) equals 1, showing conservation of power. [Figure 5](#) also shows that the reflectance around 56° — the Brewster angle in the TM case — is close to zero.

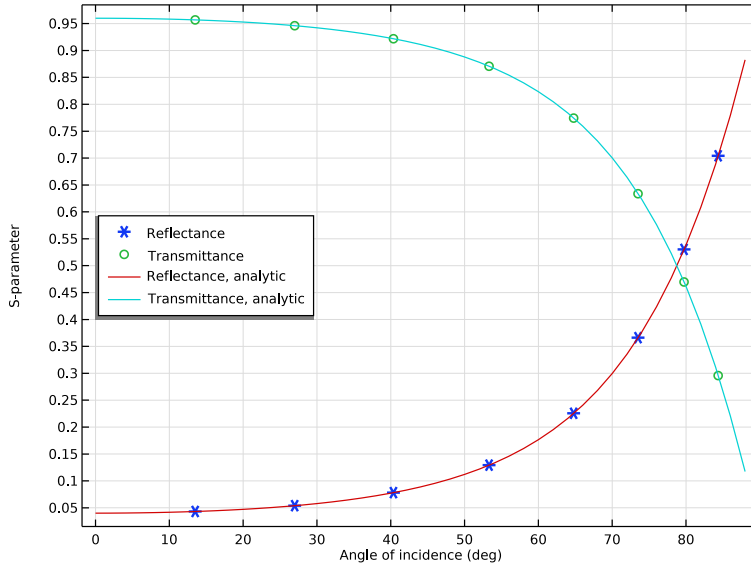

Figure 4: The reflectance and transmittance for TE incidence agree well with the analytic solutions.

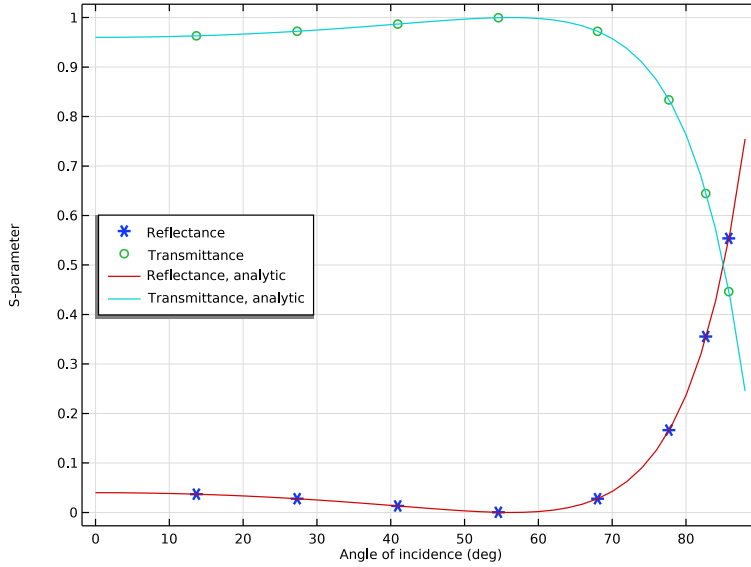

Figure 5: The reflectance and transmittance for TM incidence agree well with the analytic solutions. The Brewster angle is also observed at the expected location.

References

1. J.D. Jackson, *Classical Electrodynamics*, 3rd Ed., Wiley, 1999.
2. B.E.A. Saleh and M.C. Teich, *Fundamentals of Photonics*, Wiley, 1991.

Application Library path: RF_Module/Verification_Examples/
fresnel_equations



Modeling Instructions

From the **File** menu, choose **New**.

NEW

In the **New** window, click  **Model Wizard**.

MODEL WIZARD

- 1 In the **Model Wizard** window, click  **3D**.
- 2 In the **Select Physics** tree, select **Radio Frequency > Electromagnetic Waves, Frequency Domain (emw)**.
- 3 Click **Add**.
- 4 Click  **Study**.
- 5 In the **Select Study** tree, select **General Studies > Frequency Domain**.
- 6 Click  **Done**.

GLOBAL DEFINITIONS

Define some parameters that are useful when setting up the geometry and the study.

Parameters 1

- 1 In the **Model Builder** window, under **Global Definitions** click **Parameters 1**.
- 2 In the **Settings** window for **Parameters**, locate the **Parameters** section.

3 In the table, enter the following settings:

Name	Expression	Value	Description
n_air	1	1	Refractive index, air
n_slab	1.5	1.5	Refractive index, slab
lda0	1[m]	1 m	Wavelength
f0	c_const/lda0	2.9979E8 1/s	Frequency
alpha	70[deg]	1.2217 rad	Angle of incidence
beta	asin(n_air*sin(alpha)/n_slab)	0.67701 rad	Refraction angle
alpha_brewster	atan(n_slab/n_air)	0.98279 rad	Brewster angle, TM only
r_s	$(n_air \cdot \cos(\alpha) - n_slab \cdot \cos(\beta)) / (n_air \cdot \cos(\alpha) + n_slab \cdot \cos(\beta))$	-0.54735	Reflection coefficient, TE
r_p	$(n_slab \cdot \cos(\alpha) - n_air \cdot \cos(\beta)) / (n_air \cdot \cos(\beta) + n_slab \cdot \cos(\alpha))$	-0.20613	Reflection coefficient, TM
t_s	$(2 \cdot n_air \cdot \cos(\alpha)) / (n_air \cdot \cos(\alpha) + n_slab \cdot \cos(\beta))$	0.45265	Transmission coefficient, TE
t_p	$(2 \cdot n_air \cdot \cos(\alpha)) / (n_air \cdot \cos(\beta) + n_slab \cdot \cos(\alpha))$	0.52925	Transmission coefficient, TM

The angle of incidence is updated while running the parametric sweep. The refraction (transmitted) angle is defined by Snell's law with the updated angle of incidence. The Brewster angle exists only for TM incidence, p-polarization (polarization is in the plane of incidence).

STUDY 1 (TE)

1 In the **Model Builder** window, click **Study 1**.

2 In the **Settings** window for **Study**, type Study 1 (TE) in the **Label** text field.

Step 1: Frequency Domain

1 In the **Model Builder** window, under **Study 1 (TE)** click **Step 1: Frequency Domain**.

- 2 In the **Settings** window for **Frequency Domain**, locate the **Study Settings** section.
- 3 In the **Frequencies** text field, type f_0 .



GEOMETRY I

First, create a block composed of two domains. Use layers to split the block.

Block 1 (blk1)

- 1 In the **Geometry** toolbar, click  **Block**.
- 2 In the **Settings** window for **Block**, locate the **Size and Shape** section.
- 3 In the **Width** text field, type 0.2.
- 4 In the **Depth** text field, type 0.2.
- 5 In the **Height** text field, type 0.8.
- 6 Click to expand the **Layers** section. In the table, enter the following settings:

Layer name	Thickness (m)
Layer 1	0.4

- 7 Click  **Build All Objects**.
- 8 Click the  **Zoom Extents** button in the **Graphics** toolbar.

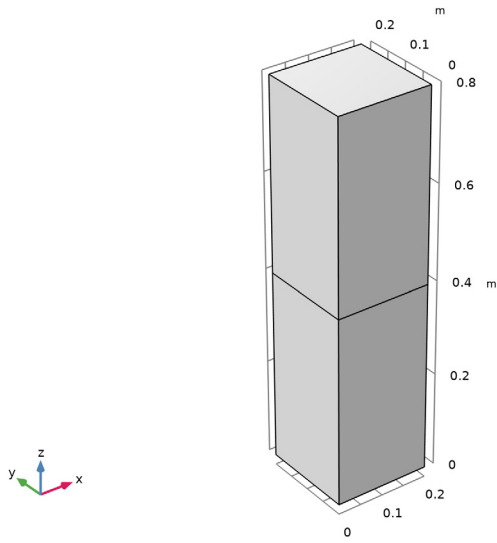

Choose wireframe rendering to get a better view of each boundary.

- 9 Click the  **Wireframe Rendering** button in the **Graphics** toolbar.

ELECTROMAGNETIC WAVES, FREQUENCY DOMAIN (TE)

Set up the physics based on the direction of propagation and the E-field polarization. First, assume a TE-polarized wave which is equivalent to s-polarization or perpendicular polarization. E_x and E_z are zero while E_y is dominant.

- 1 In the **Model Builder** window, under **Component 1 (comp1)** click **Electromagnetic Waves, Frequency Domain (emw)**.
- 2 In the **Settings** window for **Electromagnetic Waves, Frequency Domain**, type **Electromagnetic Waves, Frequency Domain (TE)** in the **Label** text field.

Periodic Structure 1

- 1 In the **Physics** toolbar, click  **Domains** and choose **Periodic Structure**.
- 2 In the **Settings** window for **Periodic Structure**, locate the **Port Mode Settings** section.
- 3 In the α_1 text field, type **alpha**.
The **Periodic Structure** node automatically adds and configures its port and periodic condition subnodes.

Wave Equation, Electric 1

- 1 In the **Model Builder** window, expand the **Periodic Structure 1** node, then click **Wave Equation, Electric 1**.
- 2 In the **Settings** window for **Wave Equation, Electric**, locate the **Electric Displacement Field** section.
- 3 From the **Electric displacement field model** list, choose **Refractive index**.

MATERIALS

Now set up the material properties based on refractive index. The top half is filled with air.

Air

- 1 In the **Model Builder** window, under **Component 1 (comp1)** right-click **Materials** and choose **Blank Material**.
- 2 In the **Settings** window for **Material**, type **Air** in the **Label** text field.
- 3 Select Domain 2 only.

4 Locate the **Material Contents** section. In the table, enter the following settings:

Property	Variable	Value	Unit	Property group
Refractive index, real part	n_{iso} ; $n_{ii} = n_{iso}$, $n_{ij} = 0$	n_{air}	l	Refractive index
Refractive index, imaginary part	$k_{i_{iso}}$; $k_{iii} =$ $k_{i_{iso}}$, $k_{ij} = 0$	0	l	Refractive index

Glass

The bottom half is glass.

1 Right-click **Materials** and choose **Blank Material**.

2 In the **Settings** window for **Material**, type Glass in the **Label** text field.

3 Select Domain 1 only.

4 Locate the **Material Contents** section. In the table, enter the following settings:

Property	Variable	Value	Unit	Property group
Refractive index, real part	n_{iso} ; $n_{ii} = n_{iso}$, $n_{ij} = 0$	n_{slab}	l	Refractive index
Refractive index, imaginary part	$k_{i_{iso}}$; $k_{iii} =$ $k_{i_{iso}}$, $k_{ij} = 0$	0	l	Refractive index

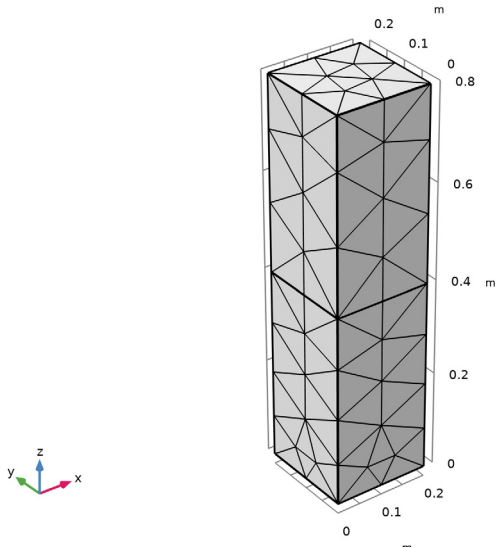

MESH 1

In the **Model Builder** window, under **Component 1 (comp1)** right-click **Mesh 1** and choose **Build All**.



STUDY 1 (TE)

Parametric Sweep

- 1 In the **Study** toolbar, click  **Parametric Sweep**.
- 2 In the **Settings** window for **Parametric Sweep**, locate the **Study Settings** section.
- 3 Click  **Add**.
- 4 In the table, enter the following settings:

Parameter name	Parameter value list	Parameter unit
alpha (Angle of incidence)	range (0, 2[deg], 88[deg])	deg

- 5 In the **Study** toolbar, click  **Compute**.

RESULTS

Electric Field (emw, TE)

- 1 In the **Settings** window for **3D Plot Group**, type Electric Field (emw, TE) in the **Label** text field.

The default plot is the E-field norm for the last solution, which corresponds to almost tangential incidence. Replace the expression with E_y , add an arrow plot of the power flow (Poynting vector), and choose a more interesting angle of incidence for the plot.

Multislice 1

- 1 In the **Model Builder** window, expand the **Electric Field (emw, TE)** node, then click **Multislice 1**.
- 2 In the **Settings** window for **Multislice**, click **Replace Expression** in the upper-right corner of the **Expression** section. From the menu, choose **Component 1 (comp1) > Electromagnetic Waves, Frequency Domain (TE) > Electric > Electric field - V/m > emw.Ey - Electric field, y-component**.
- 3 Locate the **Multipane Data** section. Find the **X-planes** subsection. In the **Planes** text field, type 0.
- 4 Find the **Z-planes** subsection. In the **Planes** text field, type 0.
- 5 Locate the **Coloring and Style** section. From the **Color table** list, choose **WaveLight**.

Arrow Volume 1

- 1 In the **Model Builder** window, right-click **Electric Field (emw, TE)** and choose **Arrow Volume**.
- 2 In the **Settings** window for **Arrow Volume**, click **Replace Expression** in the upper-right corner of the **Expression** section. From the menu, choose **Component 1 (comp1) > Electromagnetic Waves, Frequency Domain (TE) > Energy and power > emw.Poavx,..., emw.Poavz - Power flow, time average**.
- 3 Locate the **Arrow Positioning** section. Find the **Y grid points** subsection. In the **Points** text field, type 1.
- 4 Locate the **Coloring and Style** section. From the **Color** list, choose **Green**.

Electric Field (emw, TE)

- 1 In the **Model Builder** window, click **Electric Field (emw, TE)**.
- 2 In the **Settings** window for **3D Plot Group**, locate the **Data** section.
- 3 From the **Parameter value (alpha (deg))** list, choose **70**.
- 4 In the **Electric Field (emw, TE)** toolbar, click  **Plot**.

5 Click the  **Zoom Extents** button in the **Graphics** toolbar.

alpha(36)=70 deg Multislice: Electric field, y-component (V/m) Arrow Volume: Power flow, time average

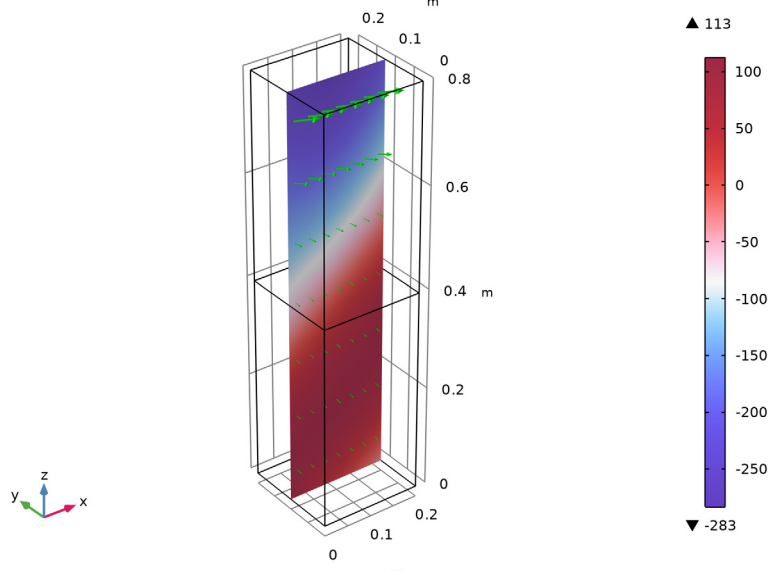

The plot should look like that in [Figure 2](#).

S-Parameter (emw, TE)

A 1D plot with the reflection and transmission versus the angle of incidence is added by default.

- 1 In the **Model Builder** window, under **Results** click **S-Parameter (emw)**.
- 2 In the **Settings** window for **ID Plot Group**, type S-Parameter (emw, TE) in the **Label** text field.
- 3 Click to expand the **Title** section. From the **Title type** list, choose **None**.
- 4 Locate the **Plot Settings** section. Select the **x-axis label** checkbox.
Replace the dB-scale variables with the linear-scale S-parameter variables.
- 5 In the **y-axis label** text field, type S-parameter.
- 6 Locate the **Legend** section. From the **Position** list, choose **Middle left**.

Global 1

- 1 In the **Model Builder** window, expand the **S-Parameter (emw, TE)** node, then click **Global 1**.
- 2 In the **Settings** window for **Global**, locate the **y-Axis Data** section.

3 In the table, enter the following settings:

Expression	Unit	Description
$\text{abs}(\text{emw.S11})^2$	1	Reflectance
$\text{abs}(\text{emw.S21})^2$	1	Transmittance

4 In the **S-Parameter (emw, TE)** toolbar, click  **Plot**.

5 Click to expand the **Coloring and Style** section. Find the **Line style** subsection. From the **Line** list, choose **None**.

6 Find the **Line markers** subsection. From the **Marker** list, choose **Cycle**.

7 From the **Positioning** list, choose **Interpolated**.

Global 2

1 In the **Model Builder** window, right-click **S-Parameter (emw, TE)** and choose **Global**.

2 In the **Settings** window for **Global**, locate the **y-Axis Data** section.

3 In the table, enter the following settings:

Expression	Unit	Description
$\text{abs}(r_s)^2$		Reflectance, analytic
$\frac{n_{\text{slab}} \cdot \cos(\beta)}{(n_{\text{air}} \cdot \cos(\alpha))} \cdot \text{abs}(t_s)^2$		Transmittance, analytic

4 Locate the **x-Axis Data** section. From the **Unit** list, choose $^\circ$.

5 Click to expand the **Legends** section. From the **Legends** list, choose **Manual**.

6 In the table, enter the following settings:

Legends
Reflectance, analytic
Transmittance, analytic

7 In the **S-Parameter (emw, TE)** toolbar, click  **Plot**.

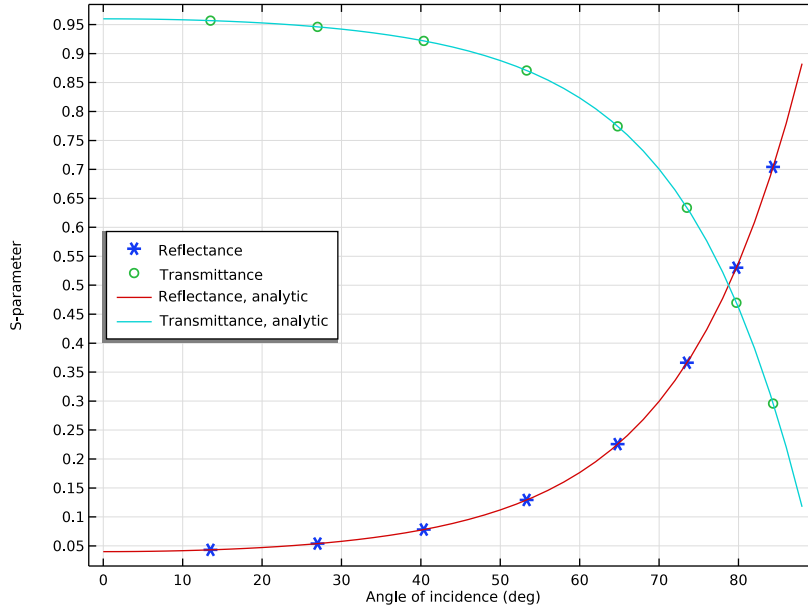

Compare the resulting plots with [Figure 4](#).

Smith Plot (emw, TE)

- 1 In the **Model Builder** window, under **Results** click **Smith Plot (emw)**.
- 2 In the **Settings** window for **Smith Plot Group**, type Smith Plot (emw, TE) in the **Label** text field.
- 3 In the **Model Builder** window, expand the **Smith Plot (emw, TE)** node.

Color Expression I

- 1 In the **Model Builder** window, expand the **Results > Smith Plot (emw, TE) > Reflection Graph I** node, then click **Color Expression I**.
- 2 In the **Settings** window for **Color Expression**, locate the **Expression** section.
- 3 In the **Expression** text field, type α .
- 4 From the **Unit** list, choose $^\circ$.

Smith Plot (emw, TE)

- 1 In the **Model Builder** window, under **Results** click **Smith Plot (emw, TE)**.
- 2 In the **Settings** window for **Smith Plot Group**, click to expand the **Title** section.
- 3 From the **Title type** list, choose **Manual**.

4 In the **Title** text area, type Reflection Graph: S-parameter, Color: Angle of incidence (deg).

5 In the **Smith Plot (emw, TE)** toolbar, click  **Plot**.

Polarization Plot (emw, TE)

1 In the **Model Builder** window, under **Results** click **Polarization Plot (emw)**.

2 In the **Settings** window for **ID Plot Group**, type Polarization Plot (emw, TE) in the **Label** text field.

3 In the **Polarization Plot (emw, TE)** toolbar, click  **Plot**.

The polarization plot shows that the field is linearly polarized, with a pure out-of-plane polarization. The out-of-plane component of the Jones vector represents the amplitude of a wave polarized in the y direction, whereas the in-plane component represents the amplitude of a wave with a polarization that is orthogonal to both the out-of-plane direction and the propagation direction, resulting in a polarization in the $x - z$ plane.

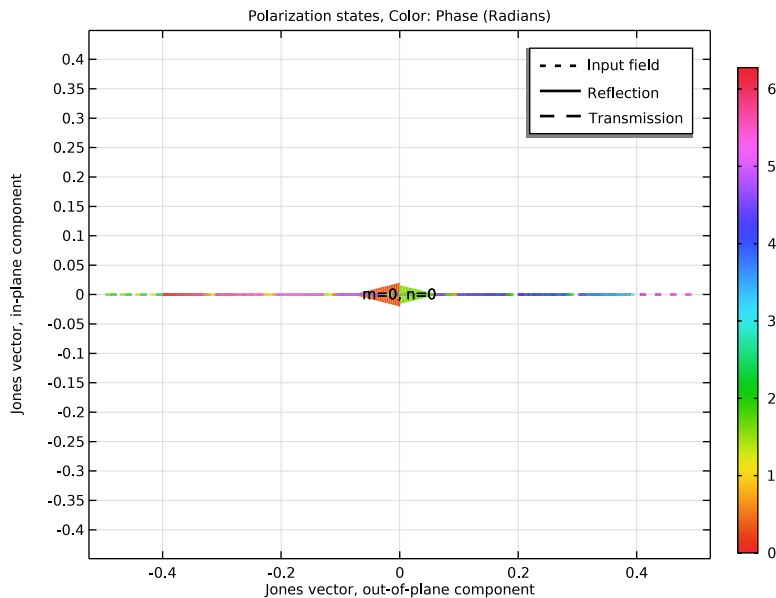

ELECTROMAGNETIC WAVES, FREQUENCY DOMAIN (TE) (EMW)

The following instructions are for the case of a TM-polarized wave (p-polarization or parallel polarization). In this case, E_y is zero while E_x and E_z characterize the wave. In other words, H_y is dominant while H_x and H_z are zero.

In the **Model Builder** window, under **Component 1 (comp1)** right-click **Electromagnetic Waves, Frequency Domain (TE) (emw)** and choose **Copy**.

ELECTROMAGNETIC WAVES, FREQUENCY DOMAIN (TM)

- 1 In the **Model Builder** window, right-click **Component 1 (comp1)** and choose **Paste Electromagnetic Waves, Frequency Domain**.
- 2 In the **Messages from Paste** dialog, click **OK**.
- 3 In the **Settings** window for **Electromagnetic Waves, Frequency Domain**, type **Electromagnetic Waves, Frequency Domain (TM)** in the **Label** text field.

STUDY 1 (TE)

Step 1: Frequency Domain



- 1 In the **Model Builder** window, under **Study 1 (TE)** click **Step 1: Frequency Domain**.
- 2 In the **Settings** window for **Frequency Domain**, locate the **Physics and Variables Selection** section.
- 3 In the **Solve for** column of the table, under **Component 1 (comp1)**, clear the checkbox for **Electromagnetic Waves, Frequency Domain (TM) (emw2)**.

ELECTROMAGNETIC WAVES, FREQUENCY DOMAIN (TM) (EMW2)

Periodic Structure 1

- 1 In the **Model Builder** window, expand the **Component 1 (comp1) > Electromagnetic Waves, Frequency Domain (TM) (emw2)** node, then click **Periodic Structure 1**.
- 2 In the **Settings** window for **Periodic Structure**, locate the **Port Mode Settings** section.
- 3 From the list, choose **Transverse magnetic (TM)**. This will change the port mode fields to be polarized parallel to the plane of incidence.

ADD STUDY

- 1 In the **Home** toolbar, click  **Add Study** to open the **Add Study** window.
- 2 Go to the **Add Study** window.
- 3 Find the **Studies** subsection. In the **Select Study** tree, select **General Studies > Frequency Domain**.
- 4 Click the **Add Study** button in the window toolbar.
- 5 In the **Home** toolbar, click  **Add Study** to close the **Add Study** window.

STUDY 2

Step 1: Frequency Domain

- 1 In the **Settings** window for **Frequency Domain**, locate the **Study Settings** section.
- 2 In the **Frequencies** text field, type f_0 .
- 3 Locate the **Physics and Variables Selection** section. In the **Solve for** column of the table, under **Component 1 (comp1)**, clear the checkbox for **Electromagnetic Waves, Frequency Domain (TE) (emw)**.
- 4 In the **Solve for** column of the table, under **Component 1 (comp1)**, select the checkbox for **Electromagnetic Waves, Frequency Domain (TM) (emw2)**.
- 5 In the **Model Builder** window, click **Study 2**.
- 6 In the **Settings** window for **Study**, type Study 2 (TM) in the **Label** text field.

Parametric Sweep

- 1 In the **Study** toolbar, click  **Parametric Sweep**.
- 2 In the **Settings** window for **Parametric Sweep**, locate the **Study Settings** section.
- 3 Click **+ Add**.
- 4 In the table, enter the following settings:

Parameter name	Parameter value list	Parameter unit
alpha (Angle of incidence)	range(0,2[deg],88[deg])	deg

- 5 In the **Study** toolbar, click  **Compute**.

RESULTS

Magnetic Field (emw2, TM)

In the **Settings** window for **3D Plot Group**, type Magnetic Field (emw2, TM) in the **Label** text field.

Multislice 1

- 1 In the **Model Builder** window, expand the **Magnetic Field (emw2, TM)** node, then click **Multislice 1**.
- 2 In the **Settings** window for **Multislice**, locate the **Expression** section.
- 3 In the **Expression** text field, type $emw2.Hy$.
- 4 Locate the **Multipane Data** section. Find the **X-planes** subsection. In the **Planes** text field, type 0.
- 5 Find the **Z-planes** subsection. In the **Planes** text field, type 0.

6 Locate the **Coloring and Style** section. From the **Color table** list, choose **WaveLight**.

Arrow Volume 1

- 1 In the **Model Builder** window, right-click **Magnetic Field (emw2, TM)** and choose **Arrow Volume**.
- 2 In the **Settings** window for **Arrow Volume**, locate the **Expression** section.
- 3 In the **X-component** text field, type emw2.Poavx .
- 4 In the **Y-component** text field, type emw2.Poavy .
- 5 In the **Z-component** text field, type emw2.Poavz .
- 6 Locate the **Arrow Positioning** section. Find the **Y grid points** subsection. In the **Points** text field, type 1.
- 7 Locate the **Coloring and Style** section. From the **Color** list, choose **Green**.
- 8 In the **Magnetic Field (emw2, TM)** toolbar, click  **Plot**.

alpha(45)=88 deg Multislice: Magnetic field, y-component (A/m) Arrow Volume: Power flow, time average

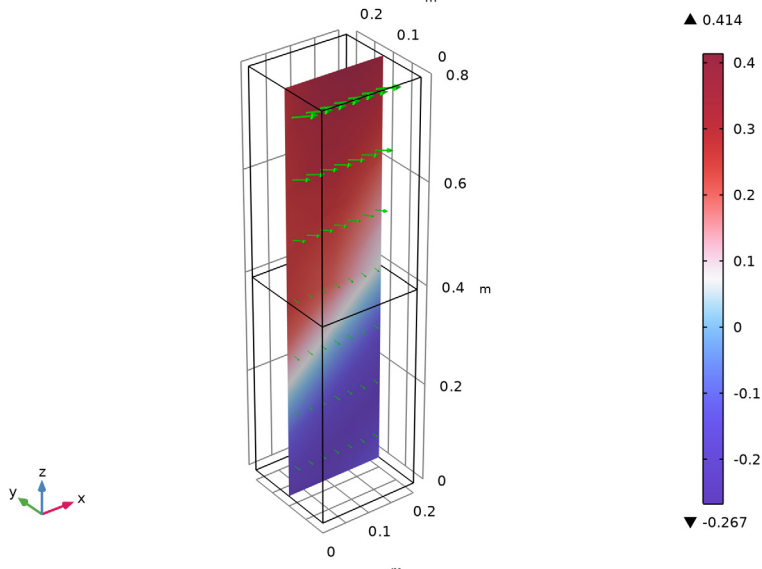

This reproduces [Figure 3](#).

S-Parameter (emw2, TM)

- 1 In the **Model Builder** window, under **Results** click **S-Parameter (emw2)**.
- 2 In the **Settings** window for **ID Plot Group**, type **S-Parameter (emw2, TM)** in the **Label** text field.

- 3 Locate the **Title** section. From the **Title type** list, choose **None**.
- 4 Locate the **Plot Settings** section. Select the **x-axis label** checkbox.
- 5 In the **y-axis label** text field, type S-parameter.
- 6 Locate the **Legend** section. From the **Position** list, choose **Middle left**.

Global 1

- 1 In the **Model Builder** window, expand the **S-Parameter (emw2, TM)** node, then click **Global 1**.
- 2 In the **Settings** window for **Global**, locate the **y-Axis Data** section.
- 3 In the table, enter the following settings:

Expression	Unit	Description
$\text{abs}(\text{emw2.S11})^2$	1	Reflectance
$\text{abs}(\text{emw2.S21})^2$	1	Transmittance

- 4 Locate the **Coloring and Style** section. Find the **Line style** subsection. From the **Line** list, choose **None**.
- 5 Find the **Line markers** subsection. From the **Marker** list, choose **Cycle**.
- 6 From the **Positioning** list, choose **Interpolated**.

Global 2

- 1 In the **Model Builder** window, right-click **S-Parameter (emw2, TM)** and choose **Global**.
- 2 In the **Settings** window for **Global**, locate the **y-Axis Data** section.
- 3 In the table, enter the following settings:

Expression	Unit	Description
$\text{abs}(r_p)^2$		Reflectance, analytic
$n_{\text{slab}} \cdot \cos(\beta) / (n_{\text{air}} \cdot \cos(\alpha)) \cdot \text{abs}(t_p)^2$		Transmittance, analytic

- 4 Click to expand the **Legends** section. From the **Legends** list, choose **Manual**.
- 5 In the table, enter the following settings:

Legends
Reflectance, analytic
Transmittance, analytic

- 6 Locate the **x-Axis Data** section. From the **Unit** list, choose °.

7 In the **S-Parameter (emw2, TM)** toolbar, click  **Plot**.

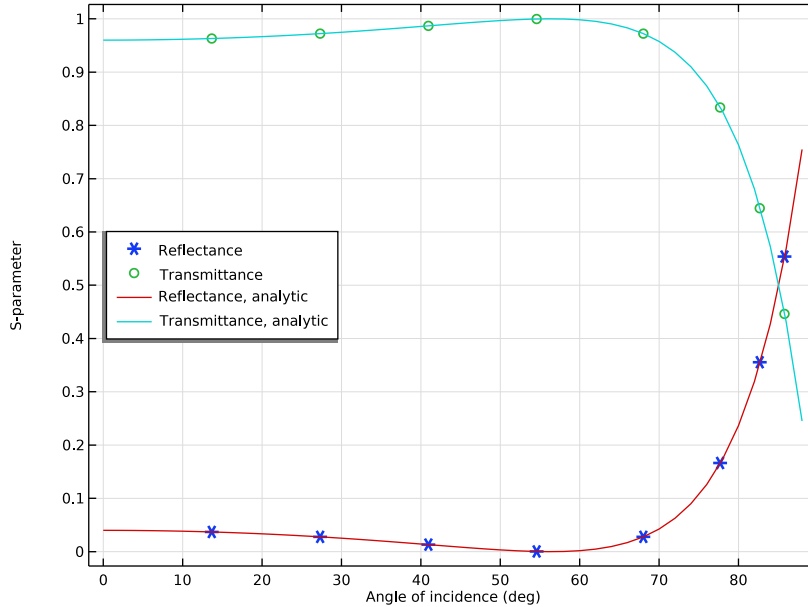

The plot should look like [Figure 5](#). The Brewster angle is observed around 56 degrees, which is close to the analytic value.

Smith Plot (emw2, TM)

- 1 In the **Model Builder** window, under **Results** click **Smith Plot (emw2)**.
- 2 In the **Settings** window for **Smith Plot Group**, type Smith Plot (emw2, TM) in the **Label** text field.
- 3 In the **Model Builder** window, expand the **Smith Plot (emw2, TM)** node.

Color Expression 1

- 1 In the **Model Builder** window, expand the **Results > Smith Plot (emw2, TM) > Reflection Graph 1** node, then click **Color Expression 1**.
- 2 In the **Settings** window for **Color Expression**, locate the **Expression** section.
- 3 In the **Expression** text field, type α .
- 4 From the **Unit** list, choose $^\circ$.

Smith Plot (emw2, TM)

- 1 In the **Model Builder** window, under **Results** click **Smith Plot (emw2, TM)**.
- 2 In the **Settings** window for **Smith Plot Group**, locate the **Title** section.

- 3 From the **Title type** list, choose **Manual**.
- 4 In the **Title** text area, type Reflection Graph: S-parameter, Color: Angle of incidence (deg).
- 5 In the **Smith Plot (emw2, TM)** toolbar, click  **Plot**.

Polarization Plot (emw2, TM)

- 1 In the **Model Builder** window, under **Results** click **Polarization Plot (emw2)**.
- 2 In the **Settings** window for **ID Plot Group**, type Polarization Plot (emw2, TM) in the **Label** text field.
- 3 In the **Polarization Plot (emw2, TM)** toolbar, click  **Plot**.

Also in this case, the polarization plot shows that the field is linearly polarized, in this case with a pure in-plane polarization.

