



Model created in COMSOL Multiphysics 6.4

Coplanar Waveguide Bandpass Filter

Introduction

Coplanar waveguide (CPW) bandpass filters can be realized using interdigital capacitors (IDCs) and short-circuited stub inductors (SSIs). Such a filter can readily be implemented on a GaAs wafer. The presented model is compact in relation to its resonant frequency and provides a relatively high Q factor compared to capacitively coupled microstrip line model designs.

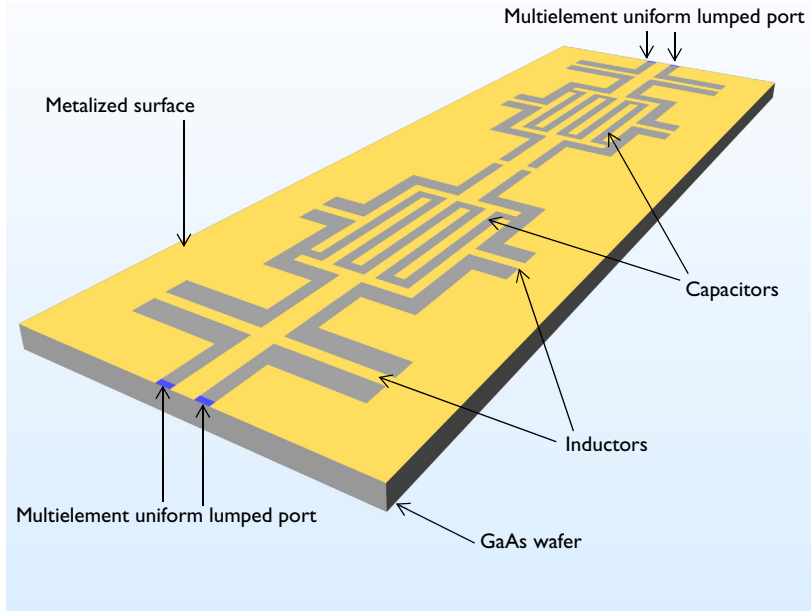

Figure 1: A coplanar waveguide bandpass filter on a 200 μm GaAs wafer composed of an interdigital capacitor and short-circuited stub inductors.

Model Definition

The structure shown in [Figure 1](#) can be realized by etching a pattern in a thin gold layer on a high dielectric ($\epsilon_r = 12.9$) GaAs substrate. In this model, the gold layer is treated as an infinitely thin layer of perfectly conducting material. Two lumped ports represent a coplanar waveguide coupling into, and out of, the device. The lumped port applies a voltage difference between the center conductor and the ground planes. This voltage difference is applied through the multielement uniform type of a lumped port that equally divides the signal between two ground planes. The line width and coupling gap on the comb in the interdigital capacitor is 100 microns, which is wide enough to account for

etching tolerances. Series and parasitic SSIs are added to generate a bandpass frequency response.

The model space consists of the GaAs wafer, with the pattern on the surface, and an air box surrounding the entire structure. The air box, in turn, is bounded by a perfect electric conductor boundary representing a die packaging placed far enough from the CPW so as not to introduce any unwanted coupling.

Results and Discussion

The structure is simulated over a range of frequencies from 7.1 GHz to 8.1 GHz. The simulation results show bandpass filter characteristics around 7.65 GHz as presented in [Figure 2](#).

Because the filter is enclosed by the PEC package, it is effectively a grounded coplanar waveguide circuit and there is a parasitic reactance between the circuit and the bottom ground plane. This reactance loading produces wider frequency responses than those generated from the circuit itself. The model without the package as well as the bottom ground plane provides sharper frequency responses.

It is generally recommended to add air bridges around SSIs when structures of this type are used for very high frequencies in order to suppress any potential radiation over the slots.

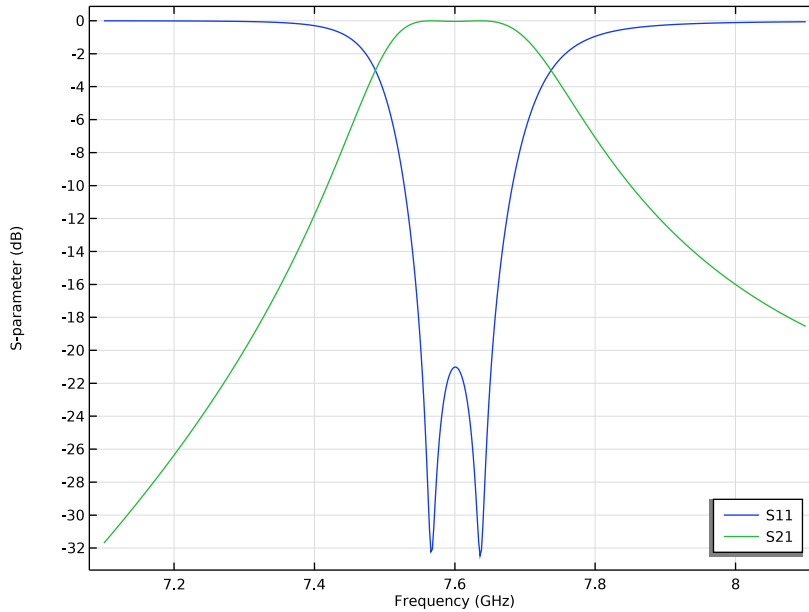



Figure 2: The frequency response of the coplanar waveguide filter shows bandpass characteristics around 7.65GHz.

Application Library path: RF_Module/Filters/cpw_bandpass_filter

Modeling Instructions

From the **File** menu, choose **New**.

NEW

In the **New** window, click  **Model Wizard**.

MODEL WIZARD

- 1** In the **Model Wizard** window, click  **3D**.
- 2** In the **Select Physics** tree, select **Radio Frequency** > **Electromagnetic Waves, Frequency Domain (emw)**.
- 3** Click **Add**.

- 4 Click  **Study**.
- 5 In the **Select Study** tree, select **Preset Studies for Selected Physics Interfaces > Frequency Domain, Modal**.
- 6 Click  **Done**.

Define the study frequency ahead of performing any frequency-dependent operation such as building mesh. The physics-controlled mesh uses the highest frequency value in the specified range.

STUDY 1

Step 1: Eigenfrequency

- 1 In the **Model Builder** window, under **Study 1** click **Step 1: Eigenfrequency**.
- 2 In the **Settings** window for **Eigenfrequency**, locate the **Study Settings** section.
- 3 In the **Search for eigenfrequencies around shift** text field, type 7.1 [GHz].



Step 2: Frequency Domain, Modal

- 1 In the **Model Builder** window, click **Step 2: Frequency Domain, Modal**.
- 2 In the **Settings** window for **Frequency Domain, Modal**, locate the **Study Settings** section.
- 3 Click  **Range**.
- 4 In the **Range** dialog, type 7.1 [GHz] in the **Start** text field.
- 5 In the **Step** text field, type 2 [MHz].
- 6 In the **Stop** text field, type 8.1 [GHz].
- 7 Click **Replace**.

GEOMETRY 1

- 1 In the **Model Builder** window, under **Component 1 (comp1)** click **Geometry 1**.
- 2 In the **Settings** window for **Geometry**, locate the **Units** section.
- 3 From the **Length unit** list, choose μm .



Import 1 (imp1)

- 1 In the **Geometry** toolbar, click  **Import**.
- 2 In the **Settings** window for **Import**, locate the **Source** section.
- 3 Click  **Browse**.
- 4 Browse to the model's Application Libraries folder and double-click the file `cpw_bandpass_filter.mphbin`.
- 5 Click  **Import**.

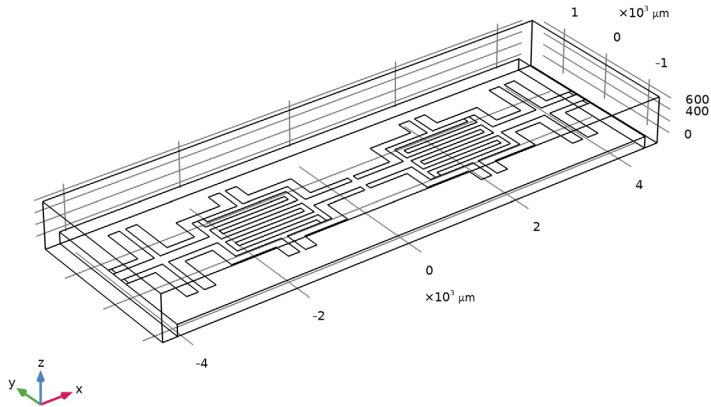
6 Click the  **Wireframe Rendering** button in the **Graphics** toolbar.



ADD MATERIAL

- 1 In the **Materials** toolbar, click  **Add Material** to open the **Add Material** window.
- 2 Go to the **Add Material** window.
- 3 In the tree, select **Built-in > Air**.
- 4 Click the **Add to Component** button in the window toolbar.
- 5 In the **Materials** toolbar, click  **Add Material** to close the **Add Material** window.

MATERIALS

GaAs

- 1 In the **Model Builder** window, under **Component 1 (comp1)** right-click **Materials** and choose **Blank Material**.
- 2 In the **Settings** window for **Material**, type GaAs in the **Label** text field.

3 Select Domain 2 only.

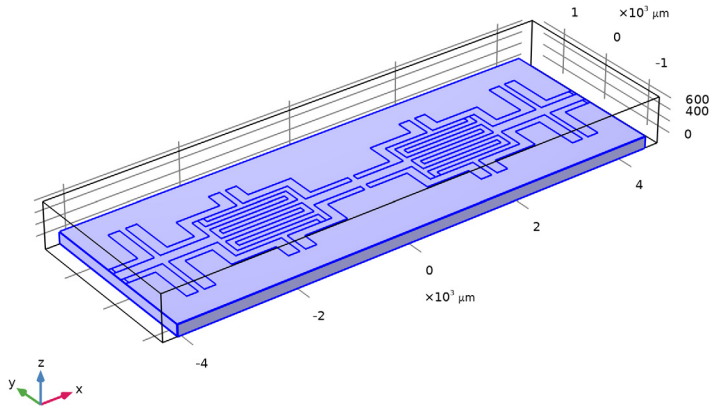

4 Locate the **Material Contents** section. In the table, enter the following settings:

Property	Variable	Value	Unit	Property group
Relative permittivity	epsilon_nr_iso ; epsilon_nrii = epsilon_nr_iso, epsilon_nrij = 0	12.9		Basic
Relative permeability	mu_r_iso ; mu_rii = mu_r_iso, mu_rij = 0	1		Basic
Electric conductivity	sigma_iso ; sigma_ii = sigma_iso, sigma_ij = 0	0	S/m	Basic

DEFINITIONS

In the **Model Builder** window, expand the **Component 1 (comp1) > Definitions** node.

View 1

Before setting up the physics, hide the air domain to get a better view and easier access to the CPW circuit geometry.

Hide for Physics 1

- 1 In the **Model Builder** window, expand the **Component 1 (comp1) > Definitions > View 1** node.
- 2 Right-click **View 1** and choose **Hide for Physics**.
- 3 Select Domain 1 only.

ELECTROMAGNETIC WAVES, FREQUENCY DOMAIN (EMW)

Perfect Electric Conductor 2

- 1 In the **Physics** toolbar, click  **Boundaries** and choose **Perfect Electric Conductor**.
- 2 Select Boundary 9 only.

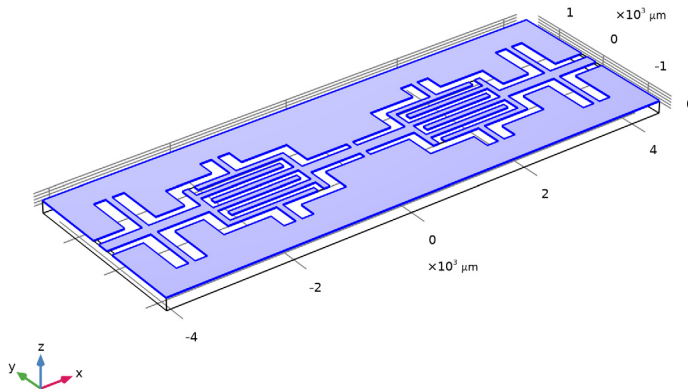

Excite and terminate each end of the CPW line using multielement uniform lumped ports.

Lumped Port 1

- 1 In the **Physics** toolbar, click  **Boundaries** and choose **Lumped Port**.

2 Select Boundaries 10 and 11 only.

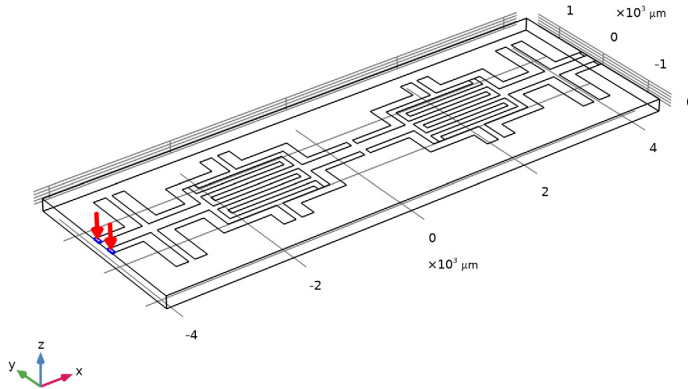

3 In the **Settings** window for **Lumped Port**, locate the **Lumped Port Properties** section.

4 From the **Type of lumped port** list, choose **Multielement uniform**.

For the first port, wave excitation is **on** by default.

5 Locate the **Boundary Selection** section. Click  **Create Selection**.

6 In the **Create Selection** dialog, Create a set of selections for use in the study settings.

7 type Lumped Port 1 in the **Selection name** text field.

8 Click **OK**.

Uniform Element 1

1 In the **Model Builder** window, expand the **Lumped Port 1** node, then click **Uniform Element 1**.

2 In the **Settings** window for **Uniform Element**, locate the **Boundary Selection** section.

3 Click  **Clear Selection**.

4 Select Boundary 11 only.

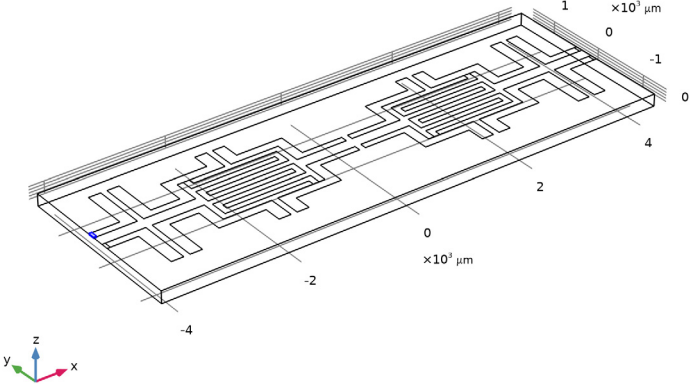

5 Locate the **Uniform Element Properties** section. Specify the \mathbf{a}_h vector as

0	x
1	y
0	z

Uniform Element 2

1 In the **Model Builder** window, click **Uniform Element 2**.

2 Select Boundary 10 only.

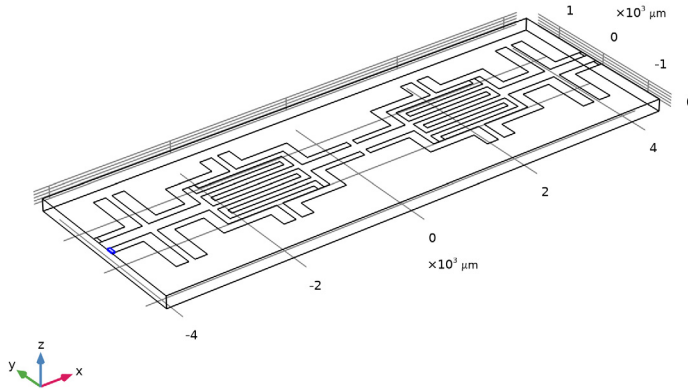

3 In the **Settings** window for **Uniform Element**, locate the **Uniform Element Properties** section.

4 Specify the \mathbf{a}_h vector as

0	x
-1	y
0	z

Lumped Port 2

1 In the **Physics** toolbar, click  **Boundaries** and choose **Lumped Port**.

2 Select Boundaries 27 and 28 only.

3 In the **Settings** window for **Lumped Port**, locate the **Lumped Port Properties** section.

4 From the **Type of lumped port** list, choose **Multielement uniform**.

5 Locate the **Boundary Selection** section. Click  **Create Selection**.

6 In the **Create Selection** dialog, type Lumped Port 2 in the **Selection name** text field.

7 Click **OK**.

Uniform Element 1

1 In the **Model Builder** window, expand the **Lumped Port 2** node, then click **Uniform Element 1**.

- 2 In the **Settings** window for **Uniform Element**, locate the **Boundary Selection** section.
- 3 Click  **Clear Selection**.
- 4 Select Boundary 28 only.
- 5 Locate the **Uniform Element Properties** section. Specify the \mathbf{a}_h vector as

0	x
1	y
0	z

Uniform Element 2

- 1 In the **Model Builder** window, click **Uniform Element 2**.
- 2 Select Boundary 27 only.
- 3 In the **Settings** window for **Uniform Element**, locate the **Uniform Element Properties** section.
- 4 Specify the \mathbf{a}_h vector as

0	x
-1	y
0	z

MESH 1

- 1 In the **Model Builder** window, under **Component 1 (comp1)** right-click **Mesh 1** and choose **Build All**.

The default frequency and material-dependent physics-controlled mesh is not fine enough to accurately evaluate the reactance of the comb structures in the IDCs. Refine the mesh settings manually.

- 2 In the **Settings** window for **Mesh**, locate the **Sequence Type** section.
- 3 From the list, choose **User-controlled mesh**.

Size 1

- 1 In the **Model Builder** window, right-click **Free Tetrahedral 1** and choose **Size**.
- 2 In the **Settings** window for **Size**, locate the **Geometric Entity Selection** section.
- 3 From the **Geometric entity level** list, choose **Boundary**.
- 4 Click  **Paste Selection**.
- 5 In the **Paste Selection** dialog, type 13-26 in the **Selection** text field.

6 Click **OK**.

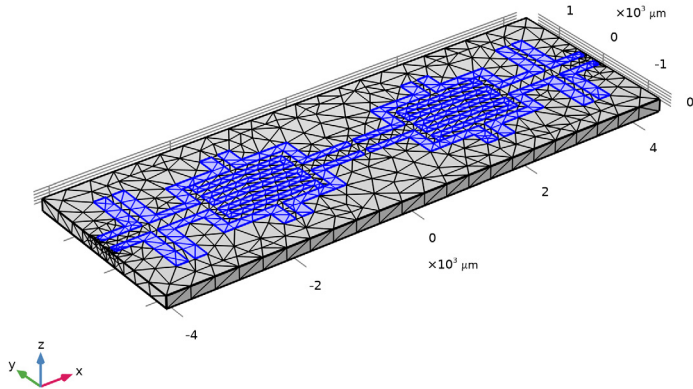

7 In the **Settings** window for **Size**, locate the **Element Size** section.

8 Click the **Custom** button.

9 Locate the **Element Size Parameters** section.

10 Select the **Maximum element size** checkbox. In the associated text field, type **80**.

11 Click  **Build All**.

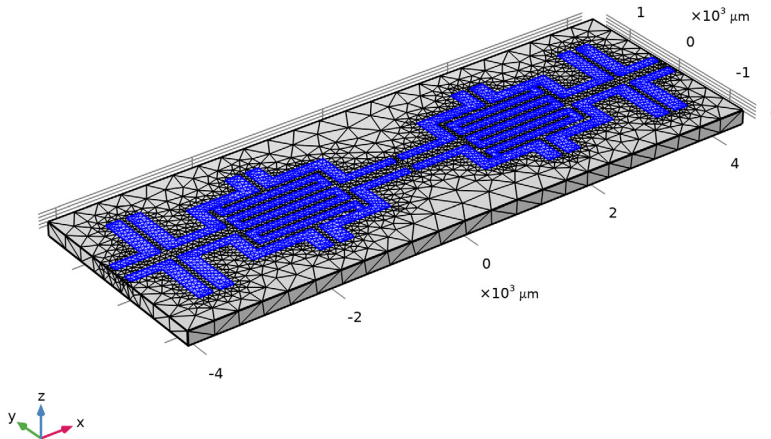



12 Click the  **Zoom Extents** button in the **Graphics** toolbar.

STUDY 1

Step 2: Frequency Domain, Modal

- 1 In the **Model Builder** window, under **Study 1** click **Step 2: Frequency Domain, Modal**.
- 2 In the **Settings** window for **Frequency Domain, Modal**, click to expand the **Store in Output** section.
- 3 In the table, enter the following settings:

Interface	Output
Electromagnetic Waves, Frequency Domain (emw)	Selection

- 4 Click to select the first row in the table.
- 5 Under **Selections**, click  **Add**.
- 6 In the **Add** dialog, in the **Selections** list, choose **Lumped Port 1** and **Lumped Port 2**.
- 7 Click **OK**.
- 8 In the **Study** toolbar, click  **Compute**.

RESULTS

Electric Field (emw)

Since the results of the **Frequency Domain Modal** analysis are stored only on the lumped port boundaries, this default E-field norm plot does not provide useful information. Switch the dataset to the solution of the **Eigenfrequency** analysis.

- 1 In the **Settings** window for **3D Plot Group**, locate the **Data** section.
- 2 From the **Dataset** list, choose **Study 1/Solution Store 1 (sol2)**.

Multislice 1

- 1 In the **Model Builder** window, expand the **Electric Field (emw)** node, then click **Multislice 1**.
- 2 In the **Settings** window for **Multislice**, locate the **Multiplane Data** section.
- 3 Find the **X-planes** subsection. In the **Planes** text field, type 0.
- 4 Find the **Y-planes** subsection. In the **Planes** text field, type 0.
- 5 Find the **Z-planes** subsection. From the **Entry method** list, choose **Coordinates**.
- 6 In the **Coordinates** text field, type 0.
- 7 In the **Electric Field (emw)** toolbar, click  **Plot**.

Eigenfrequency=7.5146+0.071211i GHz Electric field norm (V/m)

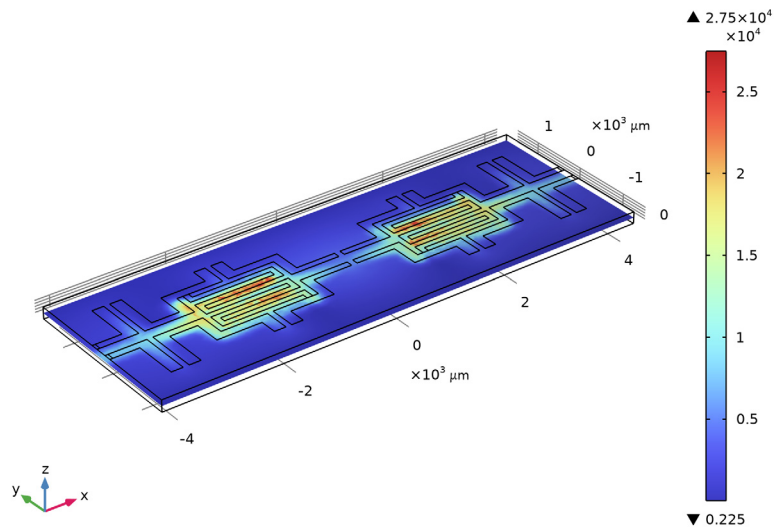

S-Parameter (emw)

- 1 In the **Model Builder** window, under **Results** click **S-Parameter (emw)**.
- 2 In the **Settings** window for **ID Plot Group**, locate the **Legend** section.
- 3 From the **Position** list, choose **Lower right**.

The S-parameter plot is shown in [Figure 2](#).

Smith Plot (emw)

In the **Model Builder** window, click **Smith Plot (emw)**.

