



Model created in COMSOL Multiphysics 6.4

Fast Numerical Modeling of a Conical Horn Lens Antenna

Introduction

An axisymmetric 3D structure such as a conical horn antenna can be simulated in a fast and efficient way using only its 2D layout. In this example, the antenna radiation and matching characteristics are computed very quickly with respect to the dominant TE mode from the given circular waveguide by simulating the 2D axisymmetric geometry of an antenna structure.

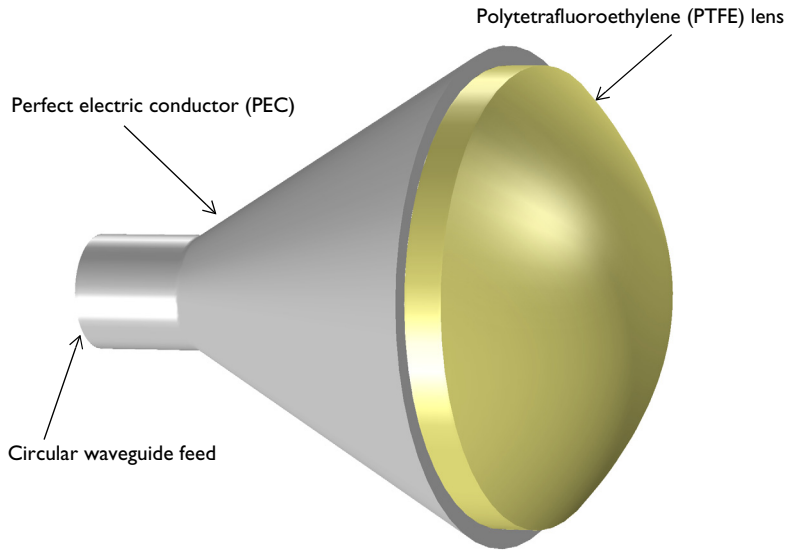

Figure 1: 3D model of the conical horn lens antenna from a 2D axisymmetric model.

Model Definition

The model consists of a conical metallic horn and a Polytetrafluoroethylene (PTFE) dielectric lens surrounded by an air domain. The outer part of the air domain truncated by perfectly matched layers (PML) that absorb the strong radiation from the horn aperture. All metal surfaces are assumed lossless, and so are modeled as perfect electric conductors (PEC). The lens material is also assumed lossless and configured as PTFE material with a low dielectric constant ($\epsilon_r = 2.1$) to avoid unwanted sudden refractive index change between the air and the dielectric.

One end of the circular waveguide is excited with a predefined TE₁ mode circular port boundary condition and the other end is connected to the conical horn, which is open to

the air domain. The combination of azimuthal mode index and the circular port mode index in a 2D axisymmetric model is compatible with the predefined circular port mode index of a 3D model. The TE_{11} mode cutoff frequency of a circular waveguide with radius 10 mm is approximately 8.8 GHz, which is calculated by

$$f_{c_{ml}} = \frac{c_0 p'_{nm}}{2\pi a}$$

where c_0 is the speed of light, p'_{nm} are the roots of the derivative of the Bessel functions $J_n(x)$, m and n are the mode indices, and a is the radius of a waveguide. The value of p'_{11} is approximately 1.841. The operating frequency of the antenna is necessarily higher than the waveguide cutoff frequency.

The circular port boundary condition is placed on the interior boundary where the reflection and transmission characteristics are computed automatically in terms of S-parameters. The interior port boundary with PEC backing for one-way excitation requires the slit condition. The port orientation is specified to define the inward direction for the S-parameter calculation.

Results and Discussion

[Figure 2](#) shows that the excited wave from the circular waveguide is traveling via the conical horn structure, confined via the dielectric lens, and generates a very directive radiation pattern. The radiation pattern is visualized in dB scale to get a better view of its sidelobes. The first sidelobe is about 22 dB lower than the main radiation lobe. The far-field radiation pattern in [Figure 2](#) is just a simple body of revolution of the 2D plot data that is useful to measure quickly the maximum gain and review the overall shape of the pattern. The effective 3D far-field radiation pattern of the antenna excited by TE_{11} mode can be estimated using the predefined postprocessing function, `normdB3DEfar_TE11 (angle)`, that is shown in [Figure 3](#).

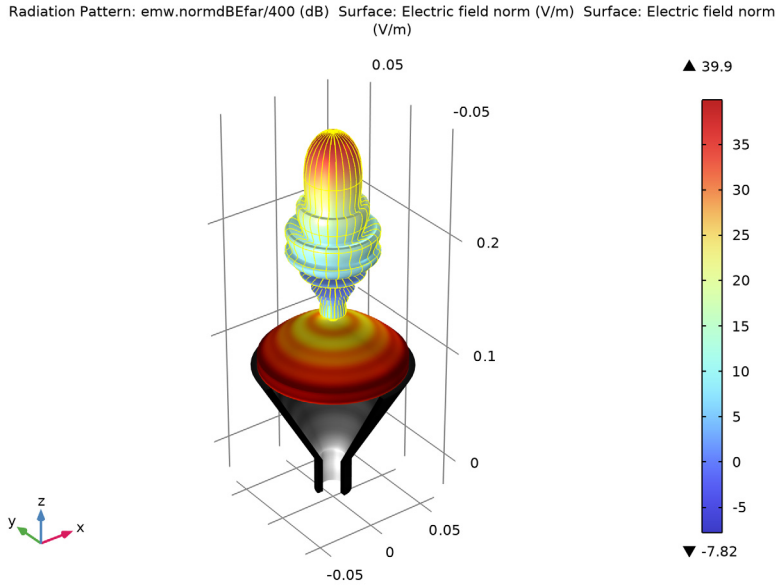

Figure 2: 3D far-field radiation pattern in dB, visualized with the grid above the lens. The E-field norm is focused gradually toward the center.

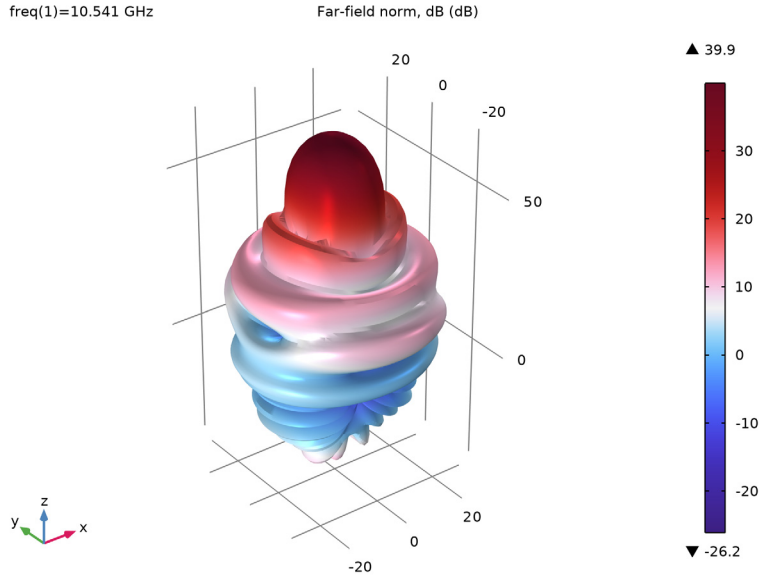



Figure 3: Effective 3D far-field radiation pattern plotted in dB scale using far-field function `normdB3DEfar_TE11(angle)`.

Application Library path: RF_Module/Antennas/conical_horn_lens_antenna

Modeling Instructions

From the **File** menu, choose **New**.

NEW

In the **New** window, click  **Model Wizard**.

MODEL WIZARD

- 1 In the **Model Wizard** window, click  **2D Axisymmetric**.
- 2 In the **Select Physics** tree, select **Radio Frequency > Electromagnetic Waves, Frequency Domain (emw)**.
- 3 Click **Add**.

- 4 Click  **Study**.
- 5 In the **Select Study** tree, select **General Studies > Frequency Domain**.
- 6 Click  **Done**.

GLOBAL DEFINITIONS

Parameters 1

- 1 In the **Model Builder** window, under **Global Definitions** click **Parameters 1**.
- 2 In the **Settings** window for **Parameters**, locate the **Parameters** section.
- 3 Click  **Load from File**.
- 4 Browse to the model's Application Libraries folder and double-click the file `conical_horn_lens_antenna_parameters.txt`.
First load the geometric parameters. Then calculate the cutoff frequency f_c to ensure that a higher value is chosen for the simulation frequency f_0 .
- 5 In the table, enter the following settings:

Name	Expression	Value	Description
f_c	$1.841 * c_const / 2 / \pi / r_1$	8.784E9 1/s	Cutoff frequency
f_0	$1.2 * f_c$	1.0541E10 1/s	Frequency

Here, `c_const` is a predefined COMSOL constant for the speed of light in vacuum.

STUDY 1

Step 1: Frequency Domain

Define the study frequency ahead of performing any frequency-dependent operation such as building mesh. The physics-controlled mesh uses the specified frequency value.

- 1 In the **Model Builder** window, under **Study 1** click **Step 1: Frequency Domain**.
- 2 In the **Settings** window for **Frequency Domain**, locate the **Study Settings** section.
- 3 In the **Frequencies** text field, type f_0 .

GEOMETRY 1

Circle 1 (c1)

- 1 In the **Geometry** toolbar, click  **Circle**.
- 2 In the **Settings** window for **Circle**, locate the **Size and Shape** section.
- 3 In the **Radius** text field, type $h_1 * 2$.

- 4 In the **Sector angle** text field, type 180.
- 5 Locate the **Position** section. In the **z** text field, type 0.05.
- 6 Locate the **Rotation Angle** section. In the **Rotation** text field, type 270.
- 7 Click to expand the **Layers** section. In the table, enter the following settings:

Layer name	Thickness (m)
Layer 1	c_const/f0

- 8 Click  **Build Selected**.

Rectangle 1 (r1)

- 1 In the **Geometry** toolbar, click  **Rectangle**.
- 2 In the **Settings** window for **Rectangle**, locate the **Size and Shape** section.
- 3 In the **Width** text field, type r1.
- 4 In the **Height** text field, type w1.
- 5 Locate the **Position** section. In the **z** text field, type -w1.

Polygon 1 (pol1)

- 1 In the **Geometry** toolbar, click  **Polygon**.
- 2 In the **Settings** window for **Polygon**, locate the **Coordinates** section.
- 3 In the table, enter the following settings:

r (m)	z (m)
0	h1*cos(angle)
r1+h1*sin(angle)	h1*cos(angle)

Polygon 2 (pol2)

- 1 In the **Geometry** toolbar, click  **Polygon**.
- 2 In the **Settings** window for **Polygon**, locate the **Coordinates** section.
- 3 In the table, enter the following settings:

r (m)	z (m)
r1	0
r1+h1*sin(angle)	h1*cos(angle)
r1+h1*sin(angle)+ht	h1*cos(angle)
r1+ht	0



Rectangle 2 (r2)

- 1 In the **Geometry** toolbar, click  **Rectangle**.
- 2 In the **Settings** window for **Rectangle**, locate the **Size and Shape** section.
- 3 In the **Width** text field, type ht.
- 4 In the **Height** text field, type w1.
- 5 Locate the **Position** section. In the **r** text field, type r1.
- 6 In the **z** text field, type -w1.

Parametric Curve 1 (pc1)

- 1 In the **Geometry** toolbar, click  **More Primitives** and choose **Parametric Curve**.
- 2 In the **Settings** window for **Parametric Curve**, locate the **Parameter** section.
- 3 In the **Maximum** text field, type max_para.
- 4 Locate the **Expressions** section. In the **r** text field, type s.
- 5 In the **z** text field, type $-(s^2) * h1ens / (max_para / 1 [m])^2$.
- 6 Locate the **Position** section. In the **z** text field, type $h1 * \cos(\text{angle}) + h1ens + 0.01$.

Rectangle 3 (r3)

- 1 In the **Geometry** toolbar, click  **Rectangle**.
- 2 In the **Settings** window for **Rectangle**, locate the **Size and Shape** section.
- 3 In the **Width** text field, type max_para.
- 4 In the **Height** text field, type 0.01.
- 5 Locate the **Position** section. In the **z** text field, type $h1 * \cos(\text{angle})$.
- 6 In the **Geometry** toolbar, click  **Build All**.

7 In the **Model Builder** window, click **Geometry 1**.

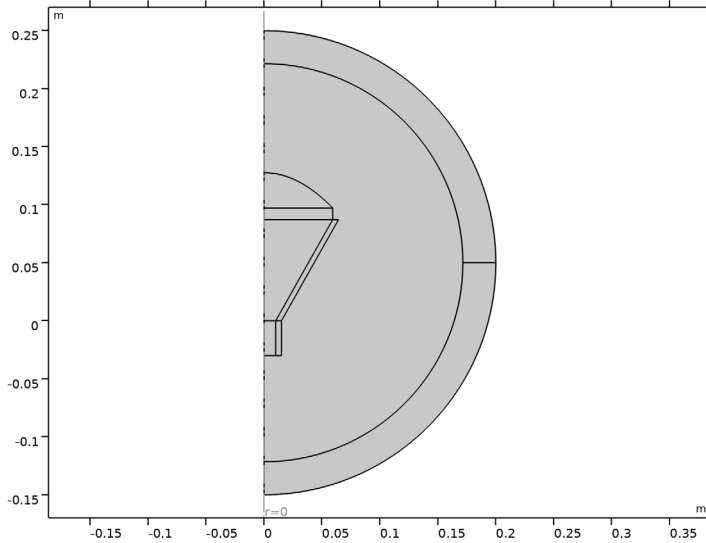



DEFINITIONS

Perfectly Matched Layer 1 (pml1)

- 1 In the **Definitions** toolbar, click  **Perfectly Matched Layer**.
- 2 Select Domains 1 and 7 only.

ADD MATERIAL

- 1 In the **Materials** toolbar, click  **Add Material** to open the **Add Material** window.
- 2 Go to the **Add Material** window.
- 3 In the tree, select **Built-in > Air**.
- 4 Click the **Add to Component** button in the window toolbar.
- 5 In the **Materials** toolbar, click  **Add Material** to close the **Add Material** window.

MATERIALS

Dielectric

- 1 In the **Model Builder** window, under **Component 1 (comp1)** right-click **Materials** and choose **Blank Material**.
- 2 In the **Settings** window for **Material**, type **Dielectric** in the **Label** text field.
- 3 Select Domains 5 and 6 only.

4 Locate the **Material Contents** section. In the table, enter the following settings:

Property	Variable	Value	Unit	Property group
Relative permittivity	epsilon _{r_} iso ; epsilon _{r_} ii = epsilon _{r_} iso, epsilon _{r_} ij = 0	2.1		Basic
Relative permeability	mu _{r_} iso ; mu _{r_} ii = mu _{r_} iso, mu _{r_} ij = 0	1		Basic
Electric conductivity	sigma _{iso} ; sigma _{ii} = sigma _{iso} , sigma _{ij} = 0	0	S/m	Basic

ELECTROMAGNETIC WAVES, FREQUENCY DOMAIN (EMW)

- 1 In the **Model Builder** window, under **Component 1 (comp1)** click **Electromagnetic Waves, Frequency Domain (emw)**.
- 2 In the **Settings** window for **Electromagnetic Waves, Frequency Domain**, locate the **Out-of-Plane Wave Number** section.
- 3 In the *m* text field, type 1.

Perfect Electric Conductor 2

- 1 In the **Physics** toolbar, click  **Boundaries** and choose **Perfect Electric Conductor**.

2 Select Boundaries 14–19 and 21 only.

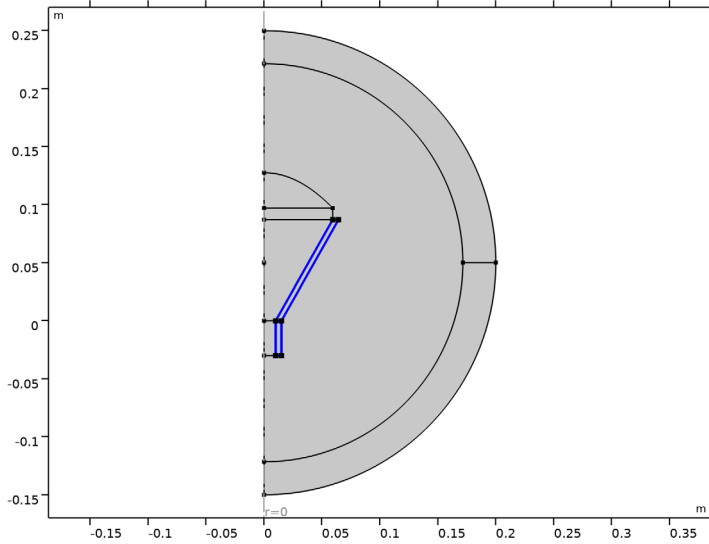

Port 1

- 1 In the **Physics** toolbar, click  **Boundaries** and choose **Port**.
- 2 Select Boundary 4 only.
- 3 In the **Settings** window for **Port**, locate the **Port Properties** section.
- 4 From the **Type of port** list, choose **Circular**.
For the first port, wave excitation is **on** by default.
- 5 Select the **Activate slit condition on interior port** checkbox.
- 6 From the **Slit type** list, choose **PEC-backed**.

7 Click **Toggle Power Flow Direction**.

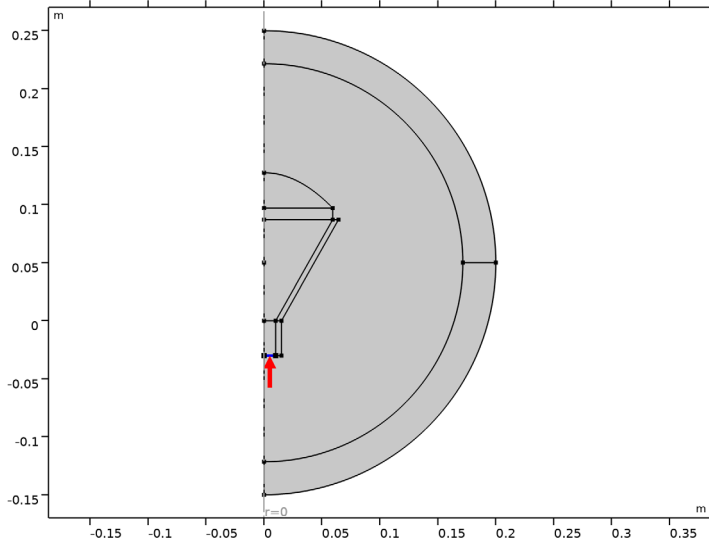

Far-Field Domain 1

In the **Physics** toolbar, click  **Domains** and choose **Far-Field Domain**.

MESH 1

I In the **Mesh** toolbar, click  **Build Mesh**.

2 In the **Model Builder** window, under **Component 1 (comp1)** click **Mesh 1**.

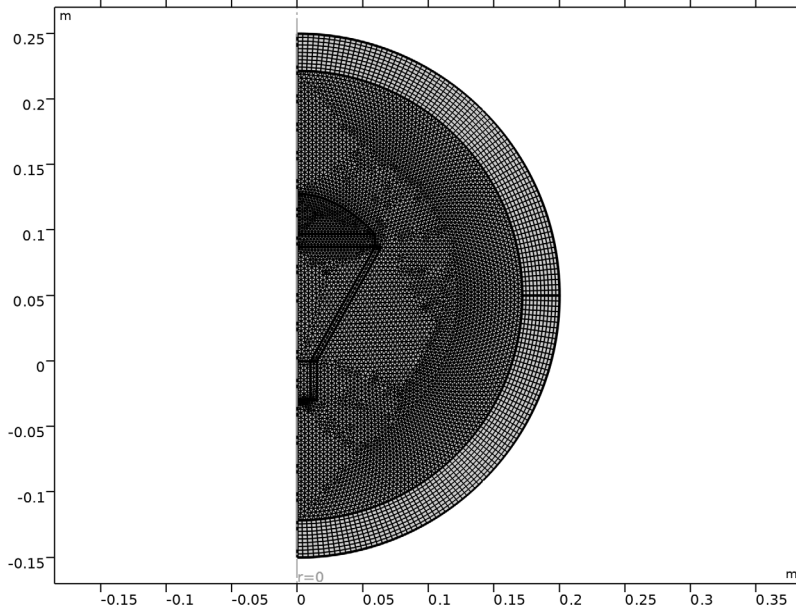

STUDY 1

Step 1: Frequency Domain

In the **Study** toolbar, click  **Compute**.

RESULTS

Electric Field (emw)

Visualize the model domains except for the perfectly matched layers.

Study 1/Solution 1 (sol1)

In the **Model Builder** window, expand the **Results > Datasets** node, then click **Study 1/Solution 1 (sol1)**.

Selection

1 In the **Results** toolbar, click  **Attributes** and choose **Selection**.

2 In the **Settings** window for **Selection**, locate the **Geometric Entity Selection** section.

3 From the **Geometric entity level** list, choose **Domain**.

4 Select Domains 2–6, 8, and 9 only.

Surface 1

- 1 In the **Model Builder** window, expand the **Electric Field (emw)** node, then click **Surface 1**.
- 2 In the **Settings** window for **Surface**, locate the **Expression** section.
- 3 In the **Expression** text field, type $\text{emw} \cdot \text{Er}$.
- 4 Click to expand the **Range** section. Select the **Manual color range** checkbox.
- 5 In the **Minimum** text field, type -1500.
- 6 In the **Maximum** text field, type 1500.

Contour 1

- 1 In the **Model Builder** window, right-click **Electric Field (emw)** and choose **Contour**.
- 2 In the **Settings** window for **Contour**, locate the **Levels** section.
- 3 In the **Total levels** text field, type 30.
- 4 Locate the **Coloring and Style** section. Clear the **Color legend** checkbox.
- 5 In the **Electric Field (emw)** toolbar, click  **Plot**.

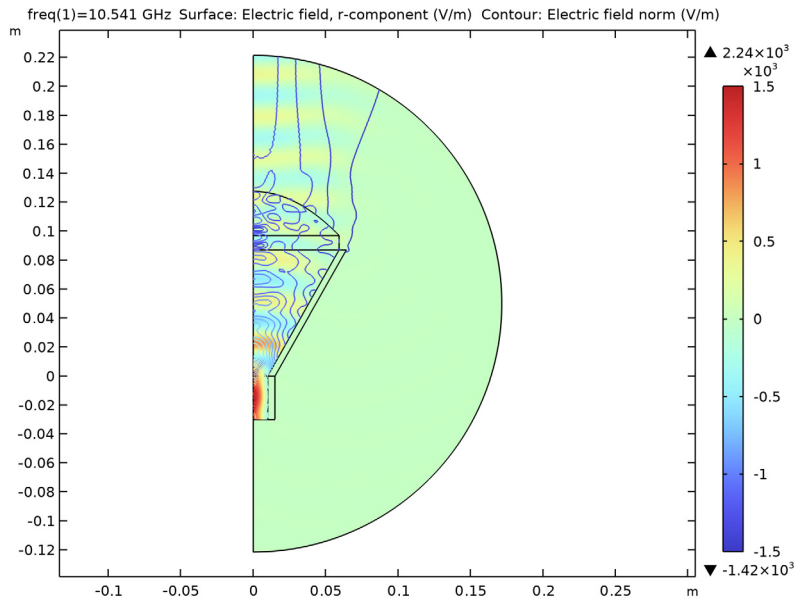

The real parts of the E_r and E-field norm contour shows that the wave is propagating toward the horn aperture and focused by the dielectric lens.

Radiation Pattern 1

Apply a finer angular resolution to get a better plot of the radiation pattern.

- 1 In the **Model Builder** window, expand the **2D Far Field (emw)** node, then click **Radiation Pattern I**.
- 2 In the **Settings** window for **Radiation Pattern**, locate the **Evaluation** section.
- 3 Find the **Reference direction** subsection. In the **x** text field, type -1.
- 4 In the **z** text field, type 0.
- 5 In the **2D Far Field (emw)** toolbar, click  **Plot**.

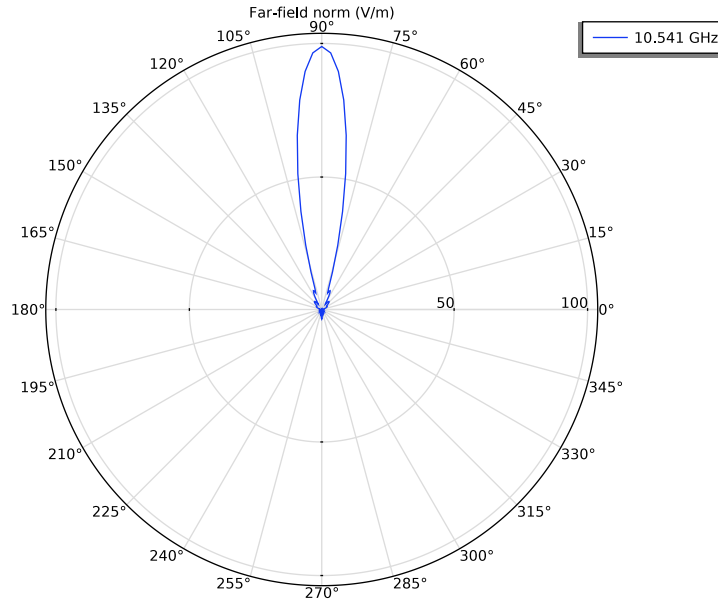



3D Far Field, Gain (emw)

Add surface plots of the antenna body and lens, and show them together with the 3D far-field radiation pattern.

Radiation Pattern I

- 1 In the **Model Builder** window, expand the **Results > 3D Far Field, Gain (emw)** node, then click **Radiation Pattern I**.
- 2 In the **Settings** window for **Radiation Pattern**, click **Replace Expression** in the upper-right corner of the **Expression** section. From the menu, choose **Component I (comp1) > Electromagnetic Waves, Frequency Domain > Far field > emw.normdBefar - Far-field norm, dB - dB**.
- 3 Locate the **Expression** section. In the **Expression** text field, type `emw.normdBefar/400`. This reduces the size of the 3D far-field radiation pattern.

- 4 Clear the **Use as color expression** checkbox.
- 5 Click **Replace Expression** in the upper-right corner of the **Color** section. From the menu, choose **Component 1 (comp1) > Electromagnetic Waves, Frequency Domain > Far field > emw.normdBefar - Far-field norm, dB - dB**.
- 6 Locate the **Evaluation** section. Find the **Angles** subsection. In the **Number of elevation angles** text field, type 90.
- 7 Locate the **Coloring and Style** section. From the **Grid** list, choose **Fine**.
- 8 From the **Color** list, choose **Yellow**.
- 9 In the **3D Far Field, Gain (emw)** toolbar, click  **Plot**.
- 10 Click the  **Zoom Extents** button in the **Graphics** toolbar.

Study 1/Solution 1 (3) (sol1)

In the **Results** toolbar, click  **More Datasets** and choose **Solution**.

Selection

- 1 In the **Results** toolbar, click  **Attributes** and choose **Selection**.
- 2 In the **Settings** window for **Selection**, locate the **Geometric Entity Selection** section.
- 3 From the **Geometric entity level** list, choose **Domain**.
- 4 Select Domains 8 and 9 only.

Revolution 2D 2

- 1 In the **Results** toolbar, click  **More Datasets** and choose **Revolution 2D**.
- 2 In the **Settings** window for **Revolution 2D**, locate the **Data** section.
- 3 From the **Dataset** list, choose **Study 1/Solution 1 (3) (sol1)**.
- 4 Click to expand the **Revolution Layers** section. In the **Start angle** text field, type -90.
- 5 In the **Revolution angle** text field, type 270.

Study 1/Solution 1 (4) (sol1)

In the **Results** toolbar, click  **More Datasets** and choose **Solution**.

Selection

- 1 In the **Results** toolbar, click  **Attributes** and choose **Selection**.
- 2 In the **Settings** window for **Selection**, locate the **Geometric Entity Selection** section.
- 3 From the **Geometric entity level** list, choose **Domain**.
- 4 Select Domains 5 and 6 only.

Revolution 2D 3

- 1 In the **Results** toolbar, click  **More Datasets** and choose **Revolution 2D**.
- 2 In the **Settings** window for **Revolution 2D**, locate the **Data** section.
- 3 From the **Dataset** list, choose **Study 1/Solution 1 (4) (sol1)**.

Surface 1

- 1 In the **Model Builder** window, right-click **3D Far Field, Gain (emw)** and choose **Surface**.
- 2 In the **Settings** window for **Surface**, locate the **Data** section.
- 3 From the **Dataset** list, choose **Revolution 2D 2**.
- 4 Locate the **Coloring and Style** section. From the **Color table** list, choose **GrayScale**.
- 5 Clear the **Color legend** checkbox.

Surface 2

- 1 Right-click **Surface 1** and choose **Duplicate**.
- 2 In the **Settings** window for **Surface**, locate the **Data** section.
- 3 From the **Dataset** list, choose **Revolution 2D 3**.
- 4 Locate the **Coloring and Style** section. From the **Color table** list, choose **ThermalDark**.
- 5 In the **3D Far Field, Gain (emw)** toolbar, click  **Plot**.

Transformation 1

- 1 In the **Model Builder** window, right-click **Radiation Pattern 1** and choose **Transformation**.
- 2 In the **Settings** window for **Transformation**, locate the **Transformation** section.
- 3 In the **PHI** text field, type 0.17.
- 4 In the **3D Far Field, Gain (emw)** toolbar, click  **Plot**.

- Click the  **Zoom Extents** button in the **Graphics** toolbar.

Radiation Pattern: emw.normdBefar/400 (dB) Surface: Electric field norm (V/m) Surface: Electric field norm (V/m)

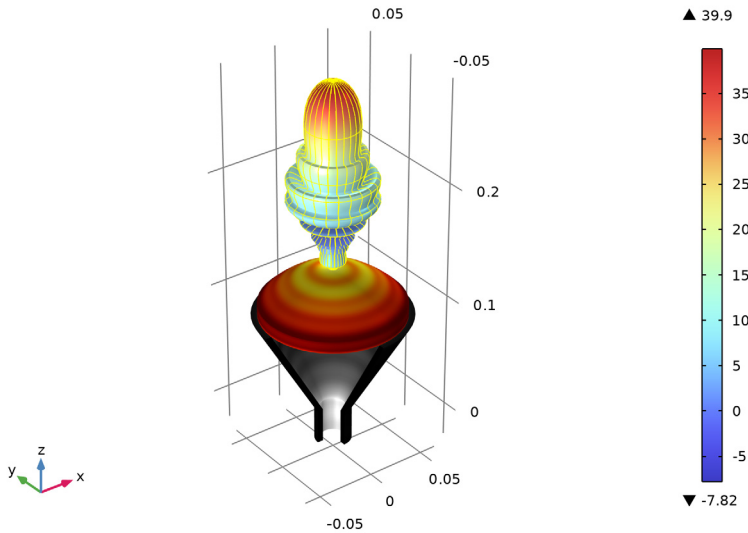

This plot should reproduce [Figure 2](#). The far-field radiation pattern plotted above is just a simple body of revolution of the 2D plot that is useful to measure quickly the maximum gain. Using the predefined postprocessing function, it is possible to estimate an effective 3D far-field radiation pattern of the antenna that is excited by the dominant mode of the 3D model of a circular waveguide, TE_{11} mode.

3D TE_{11} Mode Pattern

- In the **Results** toolbar, click  **3D Plot Group**.
- In the **Settings** window for **3D Plot Group**, type 3D TE_{11} Mode Pattern in the **Label** text field.
- Locate the **Data** section. From the **Dataset** list, choose **None**.
- Locate the **Color Legend** section. Select the **Show maximum and minimum values** checkbox.

Radiation Pattern I

- In the **3D TE_{11} Mode Pattern** toolbar, click  **More Plots** and choose **Radiation Pattern**.
- In the **Settings** window for **Radiation Pattern**, locate the **Data** section.
- From the **Dataset** list, choose **Study I/Solution I (1) (sol1)**.

- 4 Locate the **Expression** section. In the **Expression** text field, type `emw.normdB3DEfar_TE11(angle)`.
- 5 Locate the **Evaluation** section. Find the **Angles** subsection. In the **Number of elevation angles** text field, type 90.
- 6 In the **Number of azimuth angles** text field, type 90.
- 7 In the **Azimuthal angle variable** text field, type `angle`.

The far-field function contains an argument, which is given the name `angle` by default. For the azimuthal angle variable field in the Evaluation section, enter `angle` to match the function argument. Note that the name can be chosen freely as long as the function argument matches the azimuth angle variable specified in the Evaluation section.

- 8 Locate the **Coloring and Style** section. From the **Color table** list, choose **Wave**.
- 9 In the **3D TE11 Mode Pattern** toolbar, click  **Plot**.

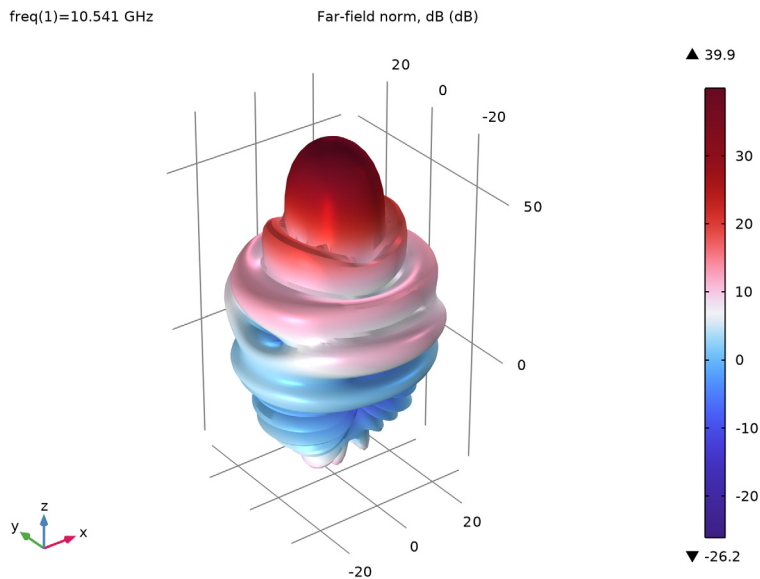

Compare the plot with [Figure 3](#).

- 10 Click the  **Show More Options** button in the **Model Builder** toolbar.
- 11 In the **Show More Options** dialog, select **Results > Information Section** in the tree.
- 12 In the tree, select the checkbox for the node **Results > Information Section**.

B Click **OK**.

When plotting a far-field radiation pattern, it may take a long time due to the finer resolution. The plotting time can be reviewed from the information section.

Port Probe

Finish by inspecting the S-parameter.