



Model created in COMSOL Multiphysics 6.4

Basic Emission and Immunity Analysis of a Circuit Board

Introduction

This example provides a walkthrough on how to simulate the basic radiated emission of a printed circuit board and its immunity response from outside noise. First, when one of the microstrip lines is excited, the crosstalk to an adjacent printed line and the radiated field, through an incomplete shield of a plastic enclosure, are computed for the emission analysis. The second study reviews the impact on the circuit board when there is radiation coming from an antenna located outside the enclosure.

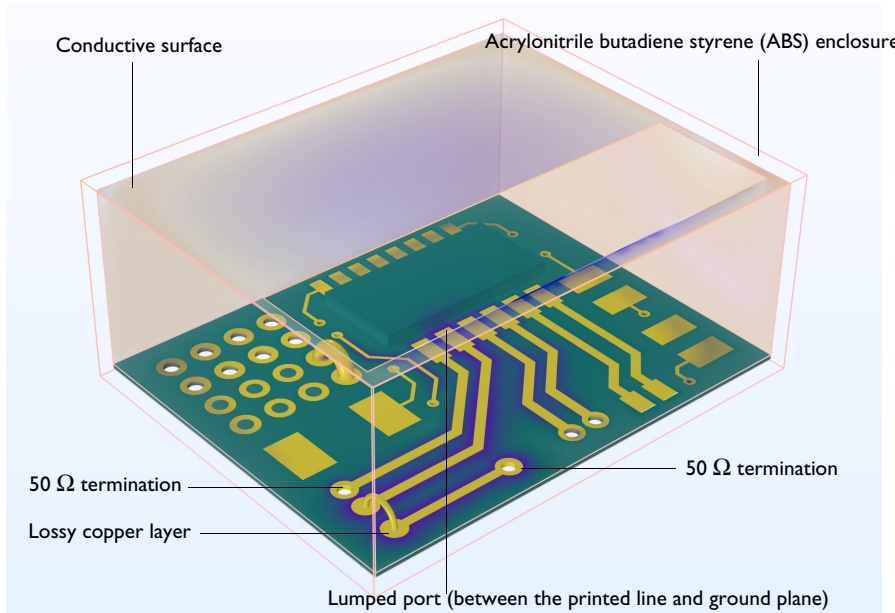

Figure 1: Mockup circuit board with an ABS enclosure finished by incomplete conductive walls. Some of the conductive walls are not included to show the interior clearly. The surrounding air domain is not shown in this figure. The printed dipole antenna for the second study is not included either in the figure.

Model Definition

The example model performs two studies with regard to the radiated emission and immunity characteristics, respectively, using a mockup circuit board placed in a shielded plastic housing. The physics settings include all the features used in both studies, but each study step selectively deactivates unnecessary boundary conditions.

Here is the list of all the physics features (boundary conditions), in addition to the default features:

TABLE I: PHYSICS FEATURE LIST

FEATURES	PURPOSE	STUDY 1	STUDY 2
Lumped Port 1	Microstrip line excitation		Disabled
Lumped Port 2	Dipole antenna excitation	Disabled	
Lumped Element 1	50 Ω via termination		
Lumped Element 2	50 Ω via termination		
Transition Boundary Condition 1	Lossy copper surfaces		
Perfect Electric Conductor 2	Printed dipole strip, lossless	Disabled	
Perfect Electric Conductor 3	Metalized vias, lossless		
Perfect Electric Conductor 4	Jumpers, lossless		
Perfect Electric Conductor 5	Shielded interior walls, lossless		
Scattering Boundary Condition 1	Absorbing boundaries		
Far-Field Domain 1 and Far-Field Calculation 1	Near-field to far-field transformation		Disabled

The mockup circuit board is made out of the FR4 material, and the printed circuit pattern is defined by a copper layer. To capture the loss that is caused by the finite conductivity in the geometrically thin copper layer, a transition boundary condition is used. The thickness of the conductive layer is set to 30 μm . The circuit board is placed in the ABS plastic housing, where the interior walls are finished by the perfect electric conductor (PEC) feature. However, the conductive surface is not completely finished and has a small window on the top of the enclosure. The radiated emission from the circuit board is leaked through this window. The amount of radiation is computed in terms of the near-field distribution as well as the far-field radiation. There is a printed dipole antenna outside the housing, and its resonance is around the Wi-Fi frequency range. The air domain encloses all the items mentioned earlier, and a scattering boundary condition is assigned on the exterior boundaries of the air domain. The scattering boundary condition absorbs all outgoing radiation, and the incident waves on the outer boundaries will not be reflected back to the source.

EMISSION TEST

One of the microstrip lines in the circuit board is excited using a uniform lumped port. The crosstalk between this signal path and another line is examined. Impedance mismatching, resonances of the copper traces, or resonances from the incompletely shielded cavity can be a source of radiated emission once they are excited. The source-

driven field is radiated via the top window. The near field and the transformed far field on the exterior boundaries are computed to evaluate the radiated emission.

IMMUNITY TEST

The second study mimics the concept of immunity tests. The source is located outside the enclosure, and the victim is the circuit board with the incompletely shielded case. A printed dipole antenna resonant around the Wi-Fi frequency is excited. The antenna radiation is coupled to the circuit board through the open window. The electric field illuminated over the circuit board and the coupled power ratio, between the antenna input and the metalized via of a selected microstrip line, is computed.

Results and Discussion

The primary emission and immunity simulations are performed in separate studies. In [Figure 2](#), the electric field norm is plotted in the dB scale with three color tables to emphasize the visual effect. When the selected line is excited, the strongest field (light yellow from the HeatCameraLight color table) is observed over the signal path. The surfaces of the FR4 board are visualized with the AuroraAustralis color table. The strongly coupled field is expressed as the blueish violet color that can be seen around all adjacent microstrip lines as well as the excited signal path. The Twilight color table is used to plot

the field on the interior boundaries of the plastic housing and the open window. The legend is activated only for the field plot on the signal path.

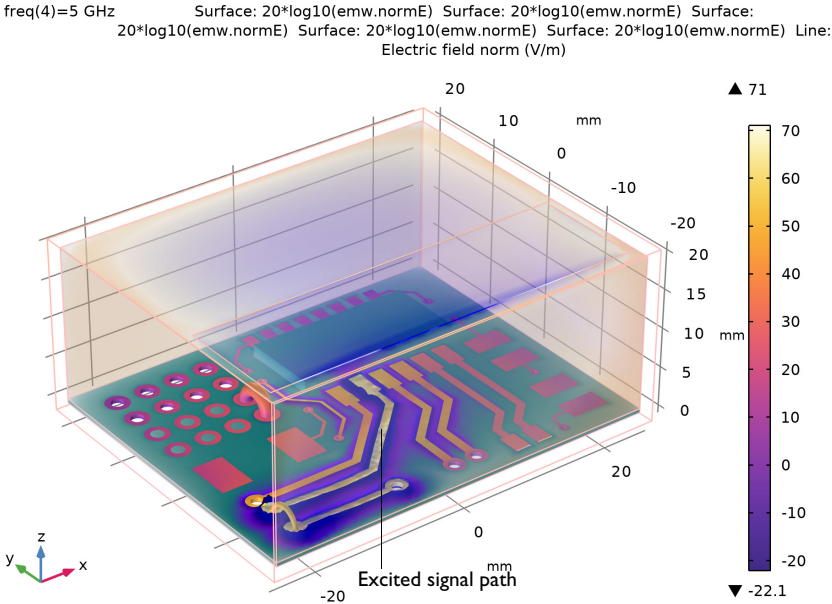

Figure 2: Three color tables are used for the electric field norm plot in the dB scale: HeatCameraLight, AuroraAustralis, and Twilight, respectively.

The directional field strength of the radiated emission is shown as a 3D far-field pattern in Figure 3. At 5 GHz, the strongest far field is generated. The far-field radiation pattern is

plotted partially transparent not to block the view of the circuit board. The depth of the transparency is controlled by the Transparency subfeature.

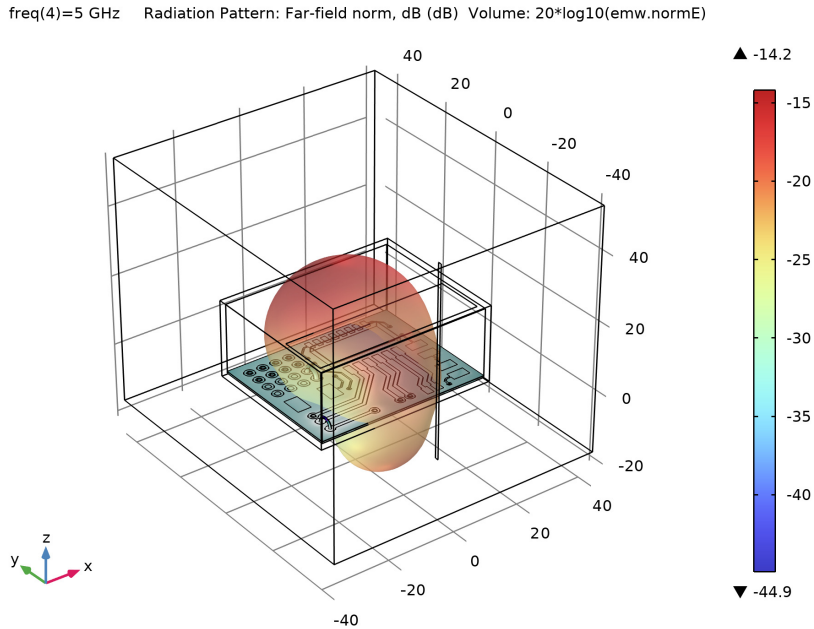

Figure 3: Radiated emission in terms of far-field radiation at 5 GHz. The electric field norm of the circuit board is also plotted with the dB scale.

For the computation of the total radiated emission, the time-averaged power outflow is integrated over the exterior boundaries. [Figure 4](#) shows the ratio between the power outflow and the input power. [Figure 5](#) shows the crosstalk between the signal path and an adjacent microstrip line. The crosstalk here is the power ratio - the power at the metalized via connected to the adjacent microstrip line normalized by the input power.

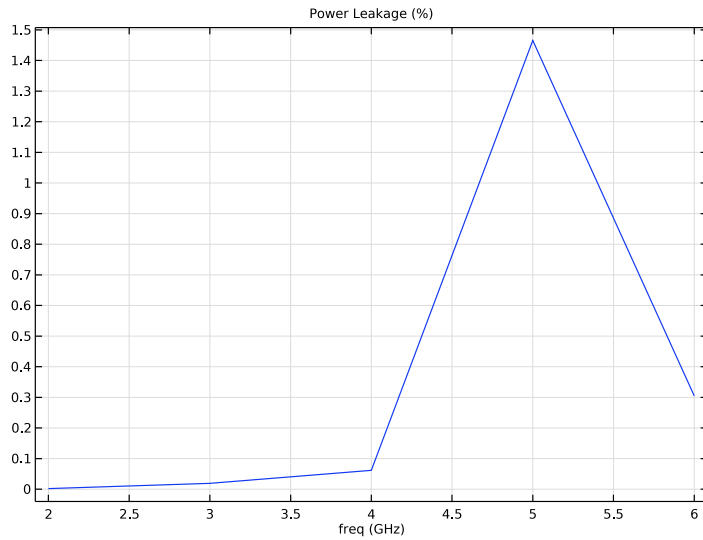

Figure 4: Leaked power ratio - the power outflow through the exterior boundaries normalized by the input power.

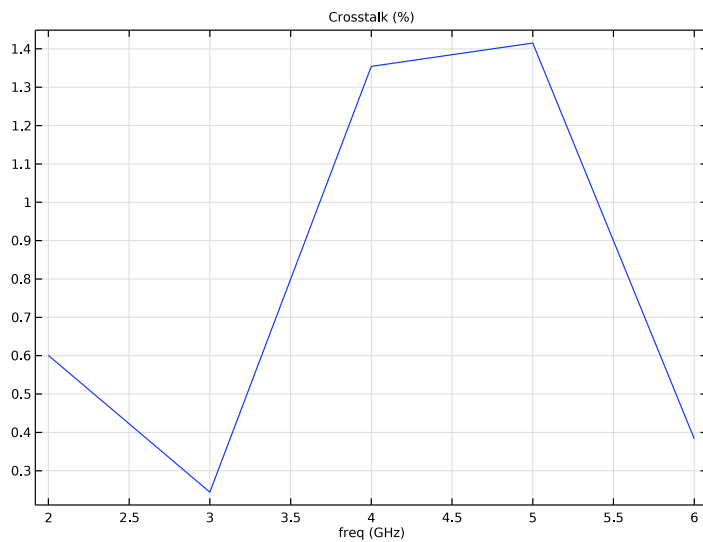

Figure 5: Crosstalk ratio, the coupled power (adjacent line) to the input power (signal path).

Figure 6 describes how much the noise from outside can impact on the signal path with an open end. The maximum coupling is observed at 5 GHz.

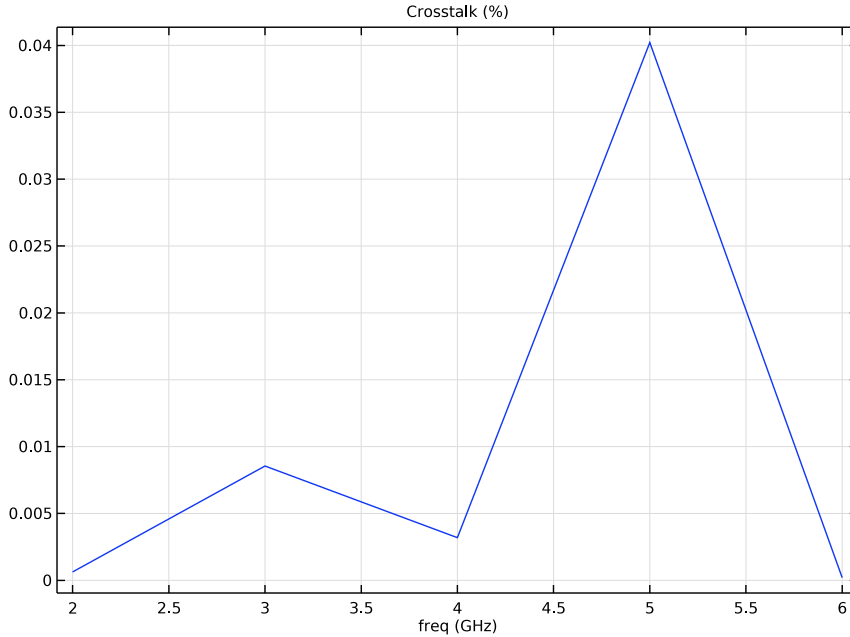

Figure 6: Impact on the microstrip line due to the radiation from the outside.

While the printed dipole antenna is supposed to work well at the Wi-Fi frequency, the maximum coupling does not occur around that frequency. The length of the signal path is about one wavelength at 5 GHz. So it could be more susceptible around 5 GHz. Another reason would be the resonance from the cavity formed by the shielded walls.

The resonant frequency of a rectangular cavity is

$$f_{nml} = \frac{c}{2\pi\sqrt{\epsilon_r\mu_r}} \sqrt{\left(\frac{m\pi}{a}\right)^2 + \left(\frac{n\pi}{b}\right)^2 + \left(\frac{l\pi}{d}\right)^2}$$

where a and b are the dimensions of the sidewall of the cavity and d is the length of the cavity. For this example, the dominant resonant frequency at TE₁₀₁ mode is close to 4.8 GHz. Because the cavity is not entirely closed and partially filled by the circuit board with metal strips, this estimation gives only an approximated value but a good clue for the susceptibility as a function of frequency.

Notes About the COMSOL Implementation

This example provides only a simplified modeling workflow for the virtual emission and immunity tests. It does not comply with the well-known test standards and protocols. The model setup has to be modified accordingly to perform the standard test.

Application Library path: RF_Module/EMI EMC_Applications/circuit_emiemc



Modeling Instructions

From the **File** menu, choose **New**.

NEW

In the **New** window, click  **Model Wizard**.



MODEL WIZARD



- 1 In the **Model Wizard** window, click  **3D**.
- 2 In the **Select Physics** tree, select **Radio Frequency > Electromagnetic Waves, Frequency Domain (emw)**.
- 3 Click **Add**.
- 4 Click  **Study**.
- 5 In the **Select Study** tree, select **General Studies > Frequency Domain**.
- 6 Click  **Done**.

GEOMETRY 1



- 1 In the **Model Builder** window, under **Component 1 (comp1)** click **Geometry 1**.
- 2 In the **Settings** window for **Geometry**, locate the **Units** section.
- 3 From the **Length unit** list, choose **mm**.

Import 1 (imp1)

- 1 In the **Geometry** toolbar, click  **Import**.
First, import a mockup circuit board.
- 2 In the **Settings** window for **Import**, locate the **Source** section.
- 3 Click  **Browse**.

- 2 In the **Settings** window for **Block**, locate the **Size and Shape** section.
- 3 In the **Width** text field, type 50[mm].
- 4 In the **Depth** text field, type 40[mm].
- 5 In the **Height** text field, type 20[mm].
- 6 Locate the **Position** section. From the **Base** list, choose **Center**.
- 7 In the **z** text field, type 10[mm].
- 8 Click  **Build Selected**.
- 9 Click the  **Wireframe Rendering** button in the **Graphics** toolbar.

Block 3 (blk3)

- 1 In the **Geometry** toolbar, click  **Block**.
- 2 In the **Settings** window for **Block**, locate the **Size and Shape** section.
- 3 In the **Width** text field, type 52[mm].
- 4 In the **Depth** text field, type 42[mm].
- 5 In the **Height** text field, type 22[mm].
- 6 Locate the **Position** section. From the **Base** list, choose **Center**.
- 7 In the **z** text field, type 10[mm].
- 8 Click  **Build Selected**.

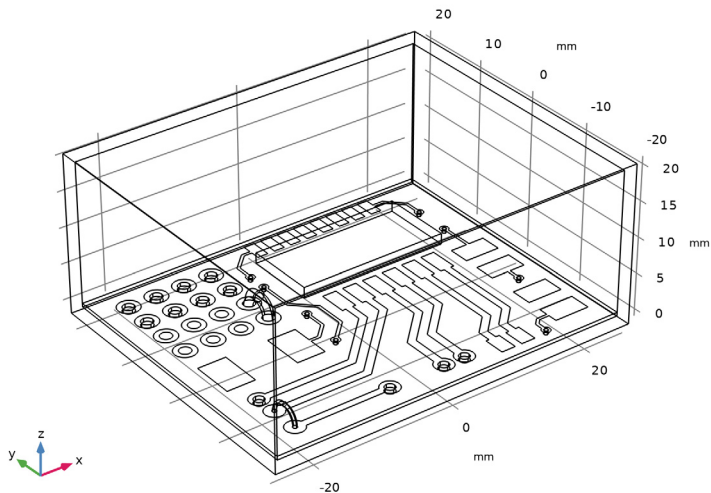

Work Plane 1 (wp1)

- 1 In the **Geometry** toolbar, click  **Work Plane**.
- 2 In the **Settings** window for **Work Plane**, locate the **Plane Definition** section.
- 3 From the **Plane type** list, choose **Face parallel**.
- 4 On the object **blk2**, select Boundary 4 only.

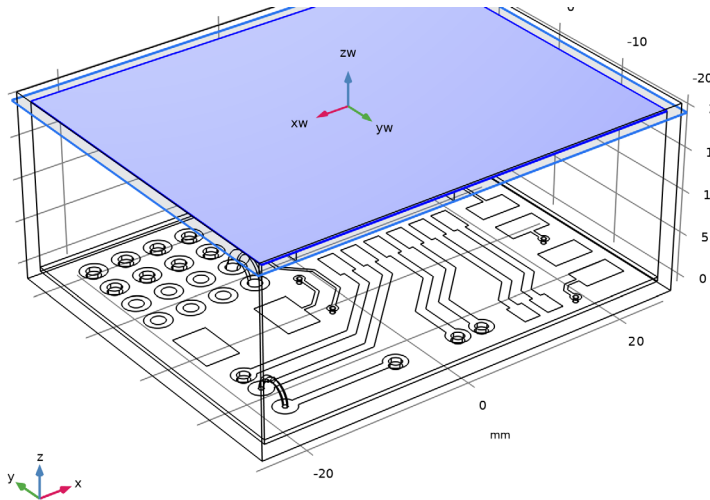

Work Plane 1 (wp1) > Plane Geometry

In the **Model Builder** window, click **Plane Geometry**.

Work Plane 1 (wp1) > Rectangle 1 (r1)

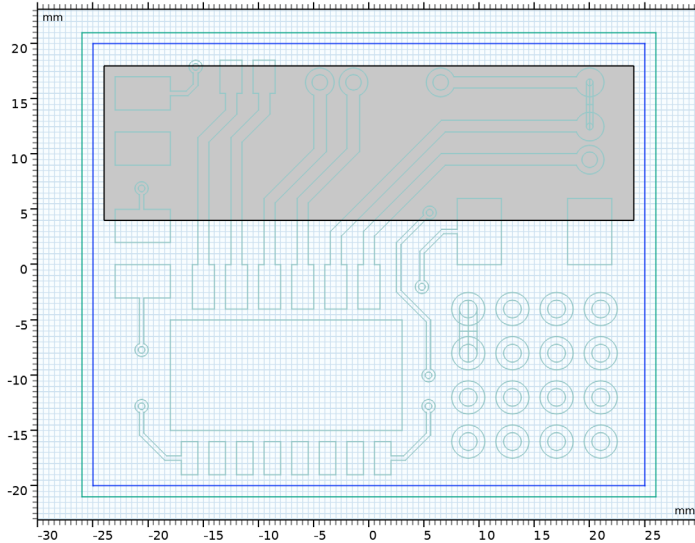

- 1 In the **Work Plane** toolbar, click  **Rectangle**.
- 2 In the **Settings** window for **Rectangle**, locate the **Size and Shape** section.
- 3 In the **Width** text field, type 48[mm].
- 4 In the **Height** text field, type 14[mm].
- 5 Locate the **Position** section. In the **xw** text field, type -24[mm].
- 6 In the **yw** text field, type 4[mm].

7 Click  **Build Selected**.



This geometry describes an open window on the top side of the enclosure.

Difference 1 (dif1)

- 1 In the **Model Builder** window, right-click **Geometry 1** and choose **Booleans and Partitions** > **Difference**.
- 2 Select the object **blk2** only.
- 3 In the **Settings** window for **Difference**, locate the **Difference** section.
- 4 Click to select the  **Activate Selection** toggle button for **Objects to subtract**.
- 5 Select the object **blk1** only.
- 6 Click  **Build Selected**.

Add a block for the surrounding air domain.

Block 4 (blk4)

- 1 In the **Geometry** toolbar, click  **Block**.
- 2 In the **Settings** window for **Block**, locate the **Size and Shape** section.
- 3 In the **Width** text field, type 80[mm].
- 4 In the **Depth** text field, type 90[mm].
- 5 In the **Height** text field, type 70[mm].
- 6 Locate the **Position** section. From the **Base** list, choose **Center**.

7 In the **z** text field, type 20[mm].

8 Click  **Build Selected**.

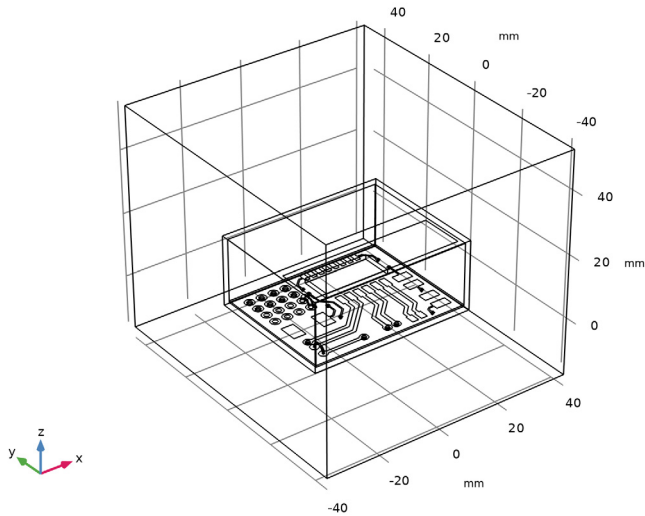

The following 2D geometry is for a printed dipole antenna.

Work Plane 2 (wp2)

1 In the **Geometry** toolbar, click  **Work Plane**.

2 In the **Settings** window for **Work Plane**, locate the **Plane Definition** section.

3 From the **Plane** list, choose **yz-plane**.

Work Plane 2 (wp2) > Plane Geometry

In the **Model Builder** window, click **Plane Geometry**.

Work Plane 2 (wp2) > Rectangle 1 (r1)

1 In the **Work Plane** toolbar, click  **Rectangle**.

2 In the **Settings** window for **Rectangle**, locate the **Size and Shape** section.

3 In the **Width** text field, type 1.

4 In the **Height** text field, type 55[mm]. The size is approximated for the antenna operating in the Wi-Fi frequency range.

5 Locate the **Position** section. From the **Base** list, choose **Center**.

6 In the **xw** text field, type -33[mm].

7 In the **yw** text field, type 20[mm].

8 Click to expand the **Layers** section. In the table, enter the following settings:

Layer name	Thickness (mm)
Layer 1	27 [mm]

9 Select the **Layers on top** checkbox.

Note that both **Layers on bottom** and **Layers on top** are checked. This creates a small rectangle in the middle of the strip where a lumped port will be assigned to excite the printed dipole antenna.

Add a small rectangular boundary for the lumped port to excite one of the printed lines on the circuit board.

Work Plane 3 (wp3)

- 1 In the **Model Builder** window, right-click **Geometry 1** and choose **Work Plane**.
- 2 In the **Settings** window for **Work Plane**, locate the **Plane Definition** section.
- 3 From the **Plane** list, choose **zx-plane**.
- 4 In the **y-coordinate** text field, type 4.

Work Plane 3 (wp3) > Plane Geometry

In the **Model Builder** window, click **Plane Geometry**.

Work Plane 3 (wp3) > Rectangle 1 (r1)

- 1 In the **Work Plane** toolbar, click  **Rectangle**.
- 2 In the **Settings** window for **Rectangle**, locate the **Size and Shape** section.
- 3 In the **Width** text field, type 0.508 [mm].
- 4 In the **Height** text field, type 2 [mm].
- 5 Locate the **Position** section. In the **yw** text field, type 2 [mm].

6 Click  **Build Selected**.

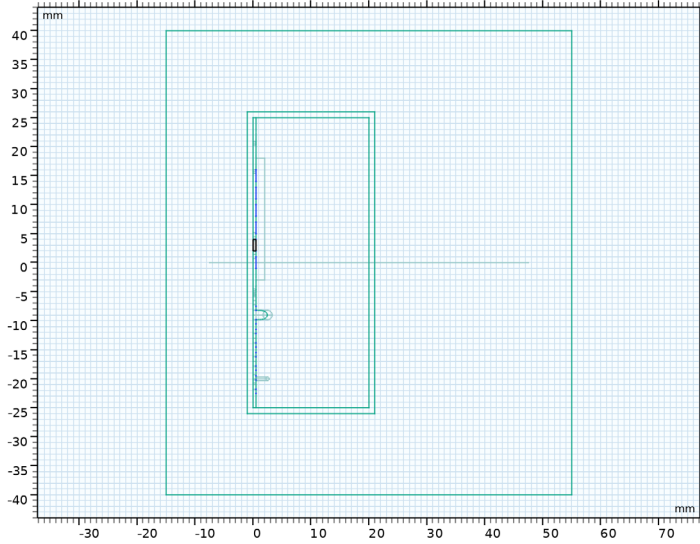

7 In the **Model Builder** window, right-click **Geometry 1** and choose **Build All**.

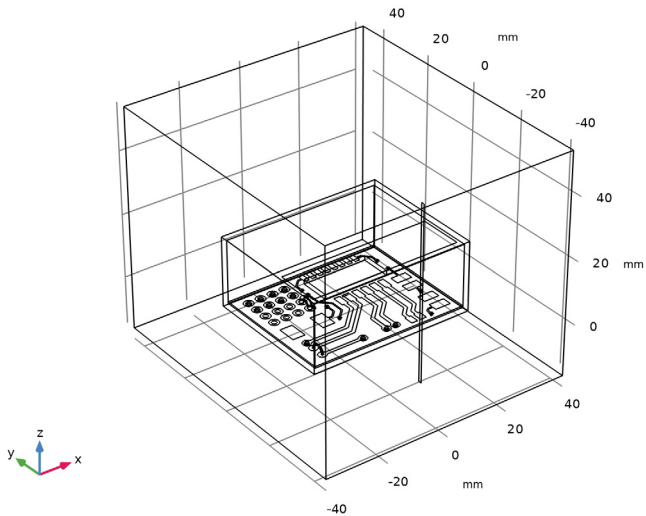

8 Click the  **Zoom Extents** button in the **Graphics** toolbar.



Define selections that are useful for configuring physics settings, material properties, and results analysis later on.

DEFINITIONS

Printed layer

- 1 In the **Definitions** toolbar, click  **Explicit**.
- 2 In the **Settings** window for **Explicit**, type Printed layer in the **Label** text field.
- 3 Locate the **Input Entities** section. From the **Geometric entity level** list, choose **Boundary**.
Use the **Select Box** feature in the graphics window to include multiple boundaries in a selection.
- 4 Click the  **Select Box** button in the **Graphics** toolbar.
- 5 Select Boundaries 21–25, 34–36, 54–57, 70–73, 86–90, 114, 115, 144, 145, 152, 153, 159–165, 169, and 172–174 only.

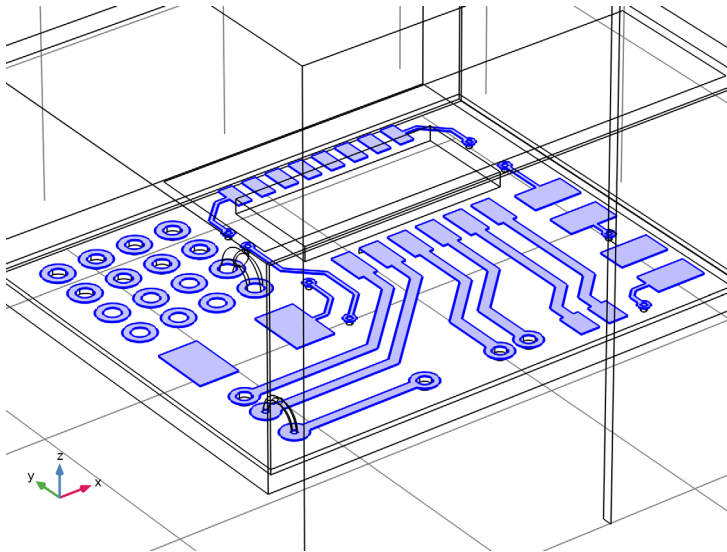

Vias

- 1 In the **Definitions** toolbar, click  **Explicit**.
- 2 In the **Settings** window for **Explicit**, type Vias in the **Label** text field.
- 3 Locate the **Input Entities** section. From the **Geometric entity level** list, choose **Boundary**.
Choose all cylindrical boundaries of metalized vias.
- 4 Select the **Group by continuous tangent** checkbox.
With **Group by continuous tangent**, you can select the curved cylindrical surface of a metalized via by selecting one of its boundary elements. The **Group by continuous tangent** allows you to select adjacent faces or edges that are continuously tangent with

the angular tolerance you specified. Select any part of the cylindrical surfaces of each via, and it will automatically select all surfaces within the angular tolerance range.

- 5 Select Boundaries 28, 29, 31, 32, 37–42, 52, 53, 60, 61, 63, 64, 66–69, 76, 77, 79, 80, 82–85, 95, 96, 98, 99, 105–110, 112, 113, 116, 117, 119, 120, 122, 123, 125–132, 134, 135, 146, 147, 149, 150, 154, 157, 158, 166, 167, 170, 171, 176, 177, 179, 180, 182, 183, and 185–190 only. These are all via boundaries.

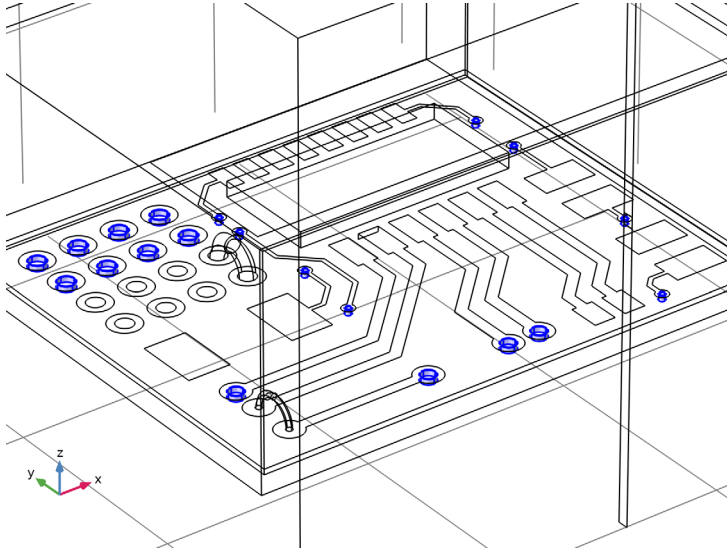

Jumpers

- 1 In the **Definitions** toolbar, click  **Explicit**.
- 2 In the **Settings** window for **Explicit**, type Jumpers in the **Label** text field.
- 3 Locate the **Input Entities** section. From the **Geometric entity level** list, choose **Boundary**.
- 4 Select the **Group by continuous tangent** checkbox.

With **Group by continuous tangent**, you can select the curved surface of the mockup jumpers easily. Select any surface of each jumper, and it will automatically select all surfaces within the angular tolerance range.

5 Select Boundaries 44–51, 91–94, and 101–104 only.

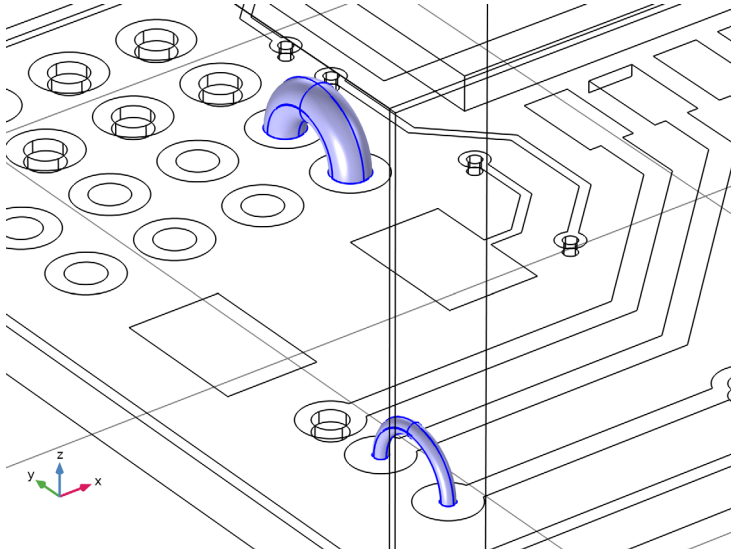

Specify the material properties for the air, circuit board, printed layer, enclosure, and chip.

ADD MATERIAL

- 1 In the **Materials** toolbar, click  **Add Material** to open the **Add Material** window.
- 2 Go to the **Add Material** window.
- 3 In the tree, select **Built-in > Air**.
- 4 Click the **Add to Component** button in the window toolbar.
- 5 In the tree, select **Built-in > FR4 (Circuit Board)**.
- 6 Click the **Add to Component** button in the window toolbar.

MATERIALS

FR4 (Circuit Board) (mat2)

Select Domain 3 only.

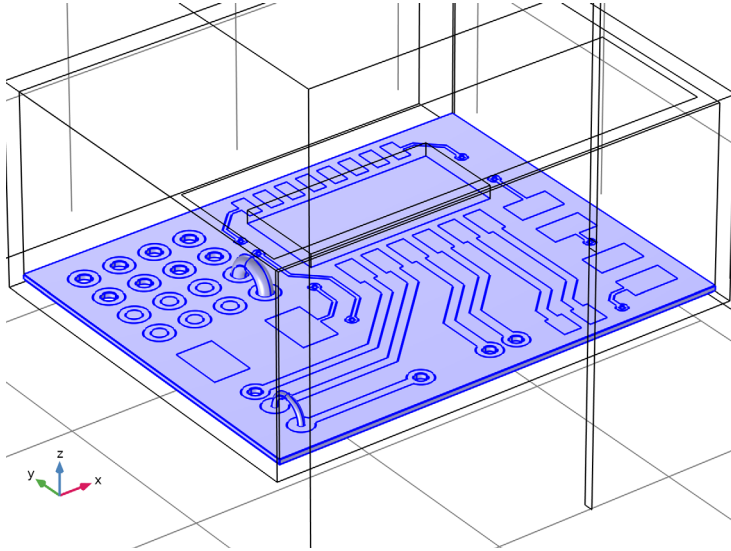

ADD MATERIAL

- 1 Go to the **Add Material** window.
- 2 In the tree, select **Built-in > Copper**.
- 3 Click the **Add to Component** button in the window toolbar.
- 4 In the **Materials** toolbar, click  **Add Material** to close the **Add Material** window.

MATERIALS

Copper - printed layer

- 1 In the **Settings** window for **Material**, type Copper - printed layer in the **Label** text field.
- 2 Locate the **Geometric Entity Selection** section. From the **Geometric entity level** list, choose **Boundary**.

3 From the **Selection** list, choose **Printed layer**.

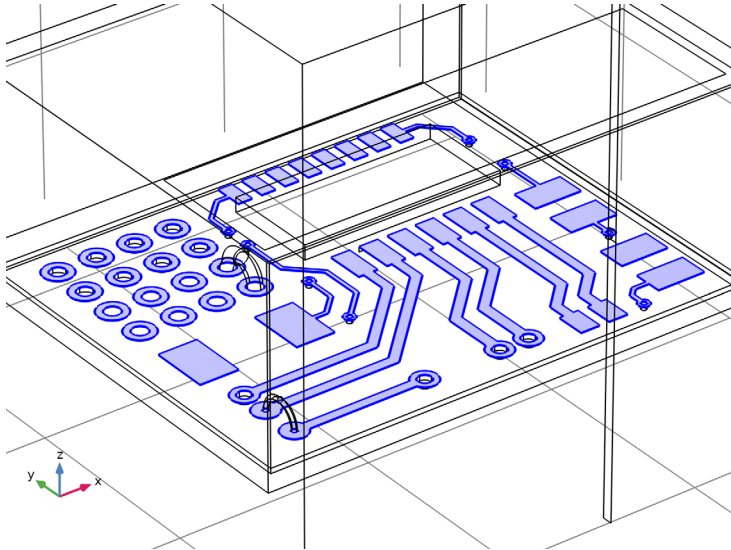

The domain material properties are automatically linked to the default **Wave Equation, Electric** domain feature in the physics settings if the **Electromagnetic Waves, Frequency Domain** interface selection includes the domain material. However, the added thin lossy conductive layer specified as boundaries in the material node should be separately included in the physics boundary feature settings to be part of the computation. This layer will be used in the **Transition Boundary Condition**.

ABS

- 1 In the **Model Builder** window, right-click **Materials** and choose **Blank Material**.
- 2 In the **Settings** window for **Material**, type ABS in the **Label** text field.

3 Select Domain 2 only.

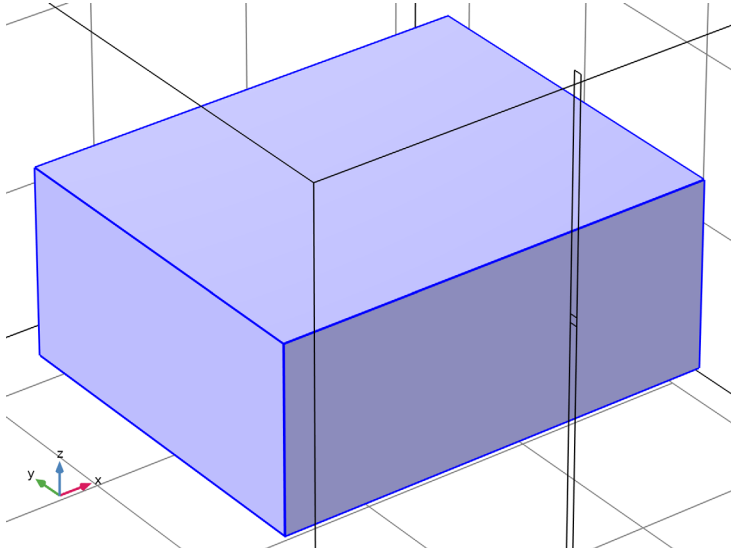

4 Locate the **Material Contents** section. In the table, enter the following settings:

Property	Variable	Value	Unit	Property group
Relative permittivity	epsilon _{nr_} iso ; epsilon _{nrii} = epsilon _{nr_} iso, epsilon _{nrij} = 0	2.9		Basic
Relative permeability	mu _{r_} iso ; mu _{rii} = mu _{r_} iso, mu _{rij} = 0	1		Basic
Electric conductivity	sigma _{iso} ; sigma _{ii} = sigma _{iso} , sigma _{ij} = 0	0	S/m	Basic

Chip

1 Right-click **Materials** and choose **Blank Material**.

2 In the **Settings** window for **Material**, type Chip in the **Label** text field.

3 Select Domain 5 only.

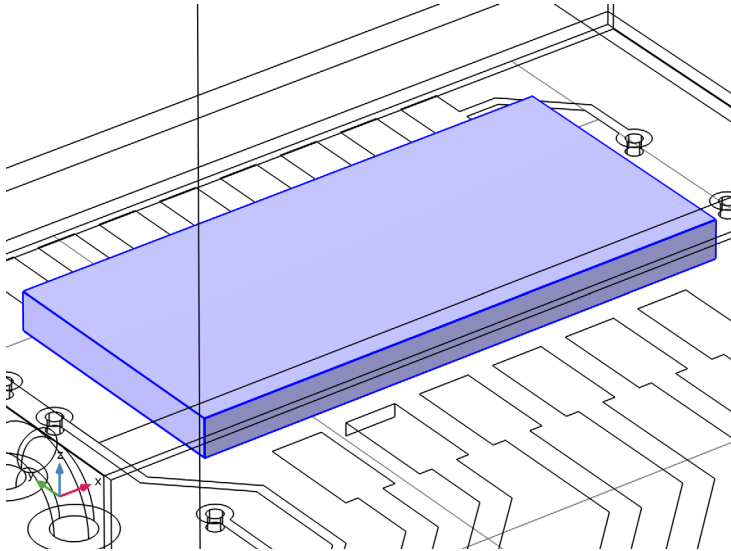

4 Locate the **Material Contents** section. In the table, enter the following settings:

Property	Variable	Value	Unit	Property group
Relative permittivity	epsilon_nr_iso ; epsilon_nrii = epsilon_nr_iso, epsilon_nrij = 0	12		Basic
Relative permeability	mu_r_iso ; mu_rii = mu_r_iso, mu_rij = 0	1		Basic
Electric conductivity	sigma_iso ; sigma_ii = sigma_iso, sigma_ij = 0	0	S/m	Basic

The physics settings include the default governing equation - the vector Helmholtz wave equation. Define lumped ports to excite the circuit or the printed antenna in the air. Add a lossy copper layer, lossless conductive boundaries, and 50 ohm terminations. Use absorbing boundaries to truncate the infinite surrounding open space. The postprocessing feature will address the far-field radiation from the circuit board.

ELECTROMAGNETIC WAVES, FREQUENCY DOMAIN (EMW)

Lumped Port 1

- 1 In the **Physics** toolbar, click  **Boundaries** and choose **Lumped Port**.
- 2 Select Boundary 151 only.

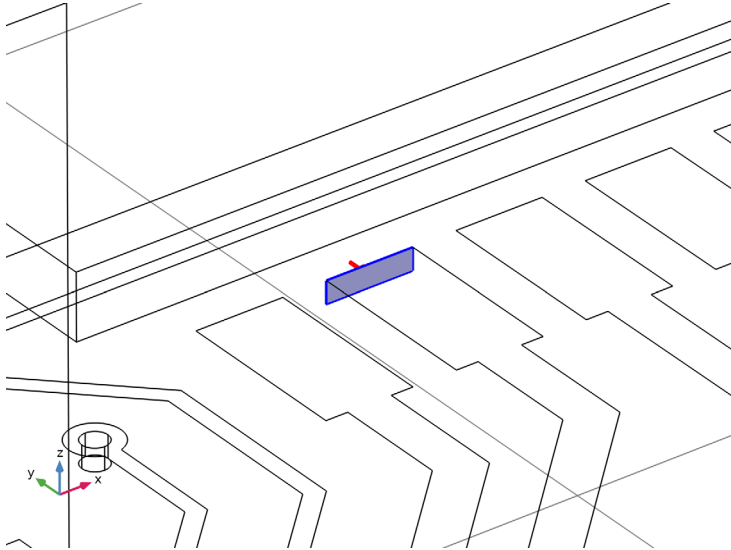

This lumped port is used to excite the circuit board in the first analysis assuming that the signal trace is a noise source. This feature is activated only in the first emission study using the **Modify model configuration for study step** option.

Lumped Port 2

- 1 In the **Physics** toolbar, click  **Boundaries** and choose **Lumped Port**.

2 Select Boundary 142 only.

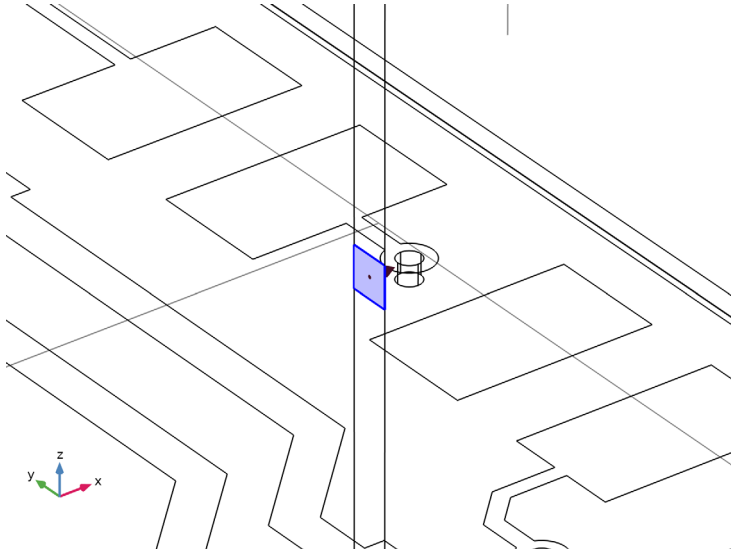

This setting is for the printed dipole antenna describing a noise source that is the radiation from outside. This feature is activated only in the second immunity study using the **Modify model configuration for study step** option.

3 In the **Settings** window for **Lumped Port**, locate the **Lumped Port Properties** section.

4 From the **Wave excitation at this port** list, choose **On**.

Perfect Electric Conductor 2

1 In the **Physics** toolbar, click  **Boundaries** and choose **Perfect Electric Conductor**.

2 Select Boundaries 141 and 143 only.

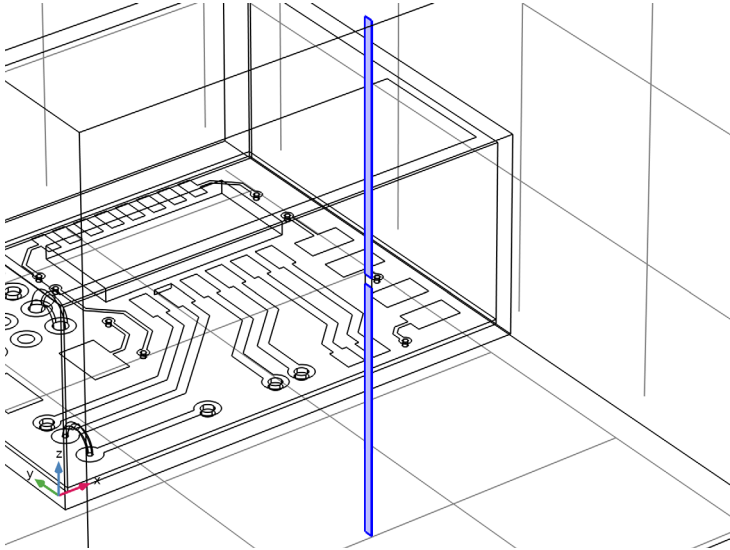

The conductive layer of the printed dipole antenna is assumed to be lossless to simplify the model. So, it is set to the **Perfect Electric Conductor**.

Next, the lossy conductive layer is defined by a **Transition Boundary Condition** feature. This feature is useful to model the behavior of a geometrically thin layer as a simple boundary.

Transition Boundary Condition 1

- 1 In the **Physics** toolbar, click  **Boundaries** and choose **Transition Boundary Condition**.
- 2 In the **Settings** window for **Transition Boundary Condition**, locate the **Boundary Selection** section.

3 From the **Selection** list, choose **Printed layer**.

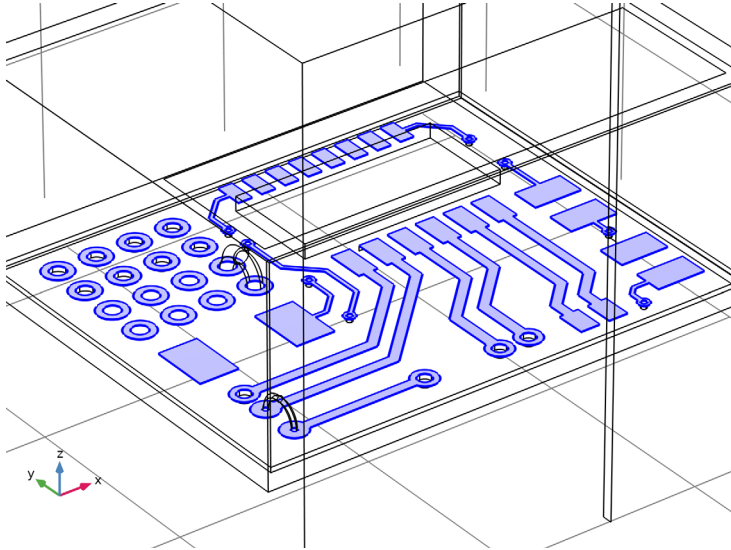

4 Locate the **Transition Boundary Condition** section. In the d text field, type $0.038[\text{mm}]$. The following **Perfect Electric Conductor** features are for the remaining conductive surfaces. If any conductive loss is expected and significant, the **Perfect Electric Conductor** can be replaced by the **Transition Boundary Condition**.

Perfect Electric Conductor 3

- 1** In the **Physics** toolbar, click  **Boundaries** and choose **Perfect Electric Conductor**.
- 2** In the **Settings** window for **Perfect Electric Conductor**, locate the **Boundary Selection** section.

3 From the **Selection** list, choose **Vias**.

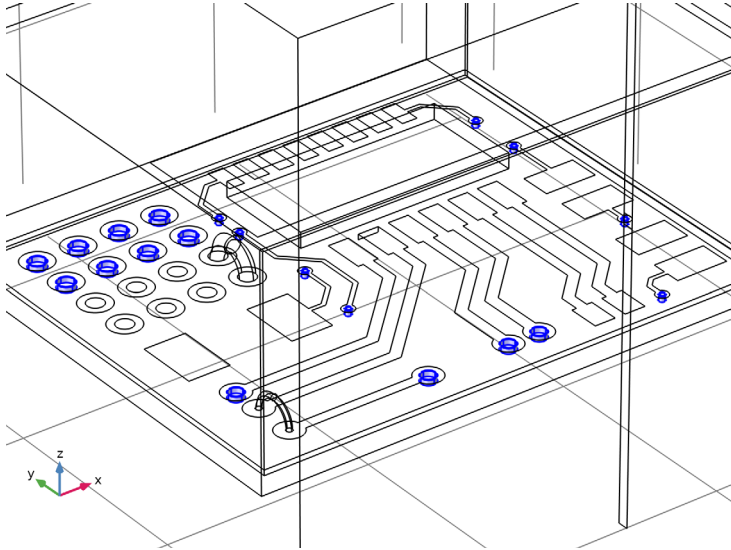

Perfect Electric Conductor 4

- 1** In the **Physics** toolbar, click  **Boundaries** and choose **Perfect Electric Conductor**.
- 2** In the **Settings** window for **Perfect Electric Conductor**, locate the **Boundary Selection** section.

3 From the **Selection** list, choose **Jumpers**.

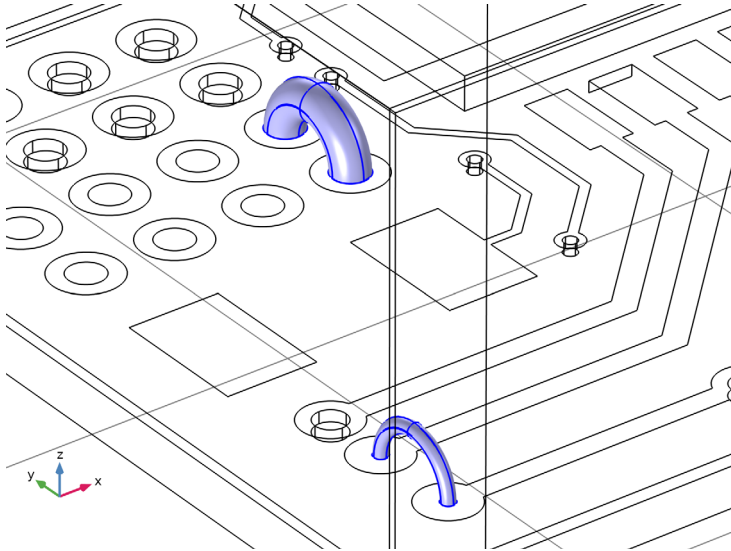

Perfect Electric Conductor 5

1 In the **Physics** toolbar, click  **Boundaries** and choose **Perfect Electric Conductor**.

2 Select Boundaries 11–15, 17–19, 191, and 192 only.

The interior walls of the enclosure are also finished by the conductive material (PEC).

Note that there is a window on the top side.

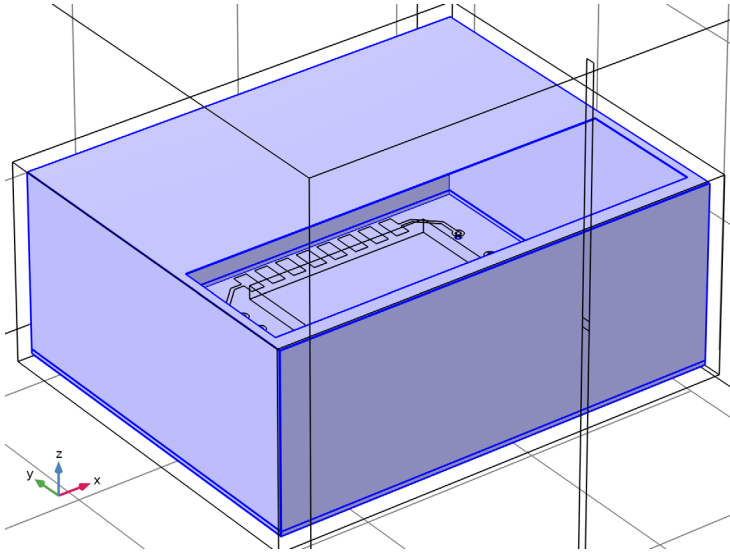

Lumped Element 1

1 In the **Physics** toolbar, click  **Boundaries** and choose **Lumped Element**.

Use **Lumped Element** features to describe passive terminations as necessary. Numerically, it is the same as the **Lumped Port** without wave excitation, but it does not calculate S-parameters.

2 Select Boundaries 109, 110, 112, and 113 only.

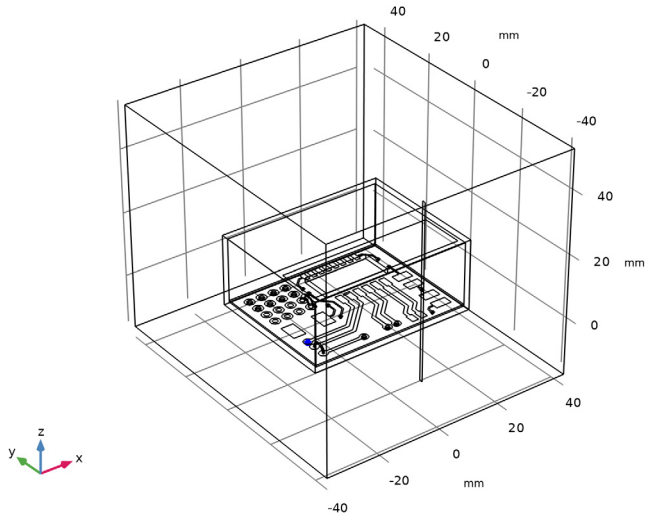

3 In the **Settings** window for **Lumped Element**, locate the **Lumped Element Properties** section.

4 From the **Type of lumped element** list, choose **Via**.

Lumped Element 2

1 In the **Physics** toolbar, click  **Boundaries** and choose **Lumped Element**.

2 Select Boundaries 41, 42, 52, and 53 only.

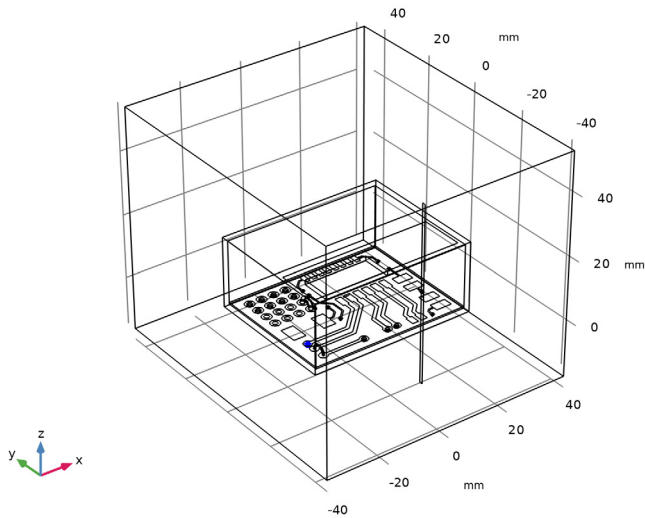

3 In the **Settings** window for **Lumped Element**, locate the **Lumped Element Properties** section.

4 From the **Type of lumped element** list, choose **Via**.

Scattering Boundary Condition I

1 In the **Physics** toolbar, click  **Boundaries** and choose **Scattering Boundary Condition**.

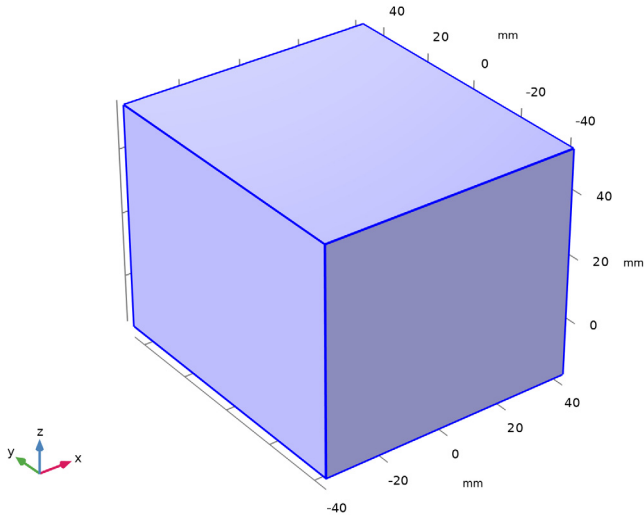

Add a **Scattering Boundary Condition** that is the first order absorbing boundary condition by default.

2 Select Boundaries 1–5 and 194 only.



Far-Field Domain and **Far-Field Calculation** features are used to compute the far-field radiation from the excited signal trace. These are activated only in the first emission study using the **Modify model configuration for study step** option.

Far-Field Domain 1

- 1 In the **Physics** toolbar, click  **Domains** and choose **Far-Field Domain**.
- 2 In the **Settings** window for **Far-Field Domain**, locate the **Domain Selection** section.
- 3 Click  **Clear Selection**.

4 Select Domain 1 only.

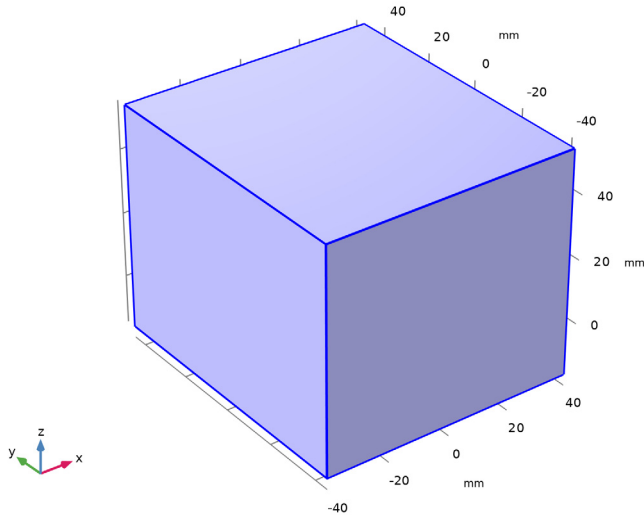

The selection of the **Far-Field Domain** feature should include a homogeneous medium, such as the surrounding air domain, to compute the near-field to far-field transformation, based on the Stratton-Chu formula.

The selection of the **Far-Field Calculation** is automatically set on the exterior boundaries of the **Far-Field Domain** when the domain feature is added.

Add an integration operator on the boundaries where the time-averaged power outflow will be analyzed.

DEFINITIONS

Integration 1 (intop1)

- 1 In the **Definitions** toolbar, click  **Nonlocal Couplings** and choose **Integration**.
- 2 In the **Settings** window for **Integration**, locate the **Source Selection** section.
- 3 From the **Geometric entity level** list, choose **Boundary**.
- 4 Select Boundaries 1–5 and 194 only.

Add variables for the result analysis.

Variables 1

- 1 In the **Model Builder** window, right-click **Definitions** and choose **Variables**.
- 2 In the **Settings** window for **Variables**, locate the **Variables** section.

3 In the table, enter the following settings:

Name	Expression	Unit	Description
power_leaked	intop1(emw.nPoav)	W	Leaked power outside the enclosure
power_input	$(1[V])^2 / (2 * 50[\text{ohm}])$	W	Input power

The default physics-controlled mesh set the maximum mesh size 0.2 wavelengths that is also scaled by material properties.

MESH 1

In the **Model Builder** window, under **Component 1 (comp1)** right-click **Mesh 1** and choose **Build All**.

To see the interior, several boundaries can be removed from the view.

DEFINITIONS

Hide for Physics 1

- 1 In the **Model Builder** window, right-click **View 1** and choose **Hide for Physics**.
- 2 Click the  **Transparency** button in the **Graphics** toolbar.
- 3 In the **Settings** window for **Hide for Physics**, locate the **Geometric Entity Selection** section.
- 4 From the **Geometric entity level** list, choose **Boundary**.

5 Select Boundaries 1, 2, 4, 6, 7, 9, 14, 15, and 20 only.

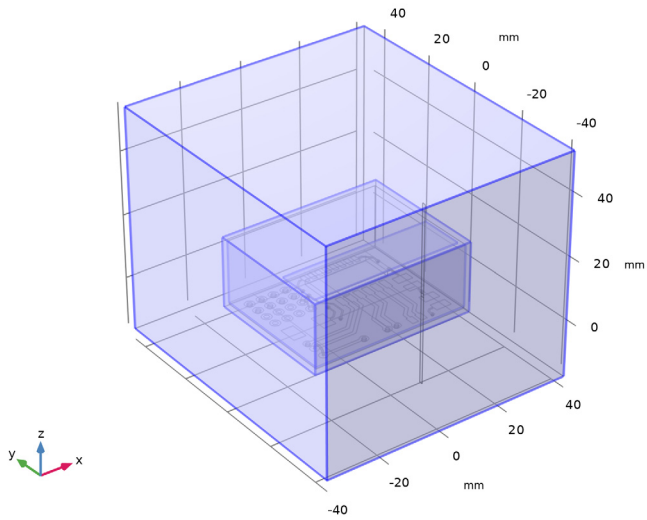

6 Click the  **Transparency** button in the **Graphics** toolbar.

MESH 1

1 Click the  **Zoom In** button in the **Graphics** toolbar.

- 2 In the **Model Builder** window, under **Component 1 (comp1)** click **Mesh 1**.

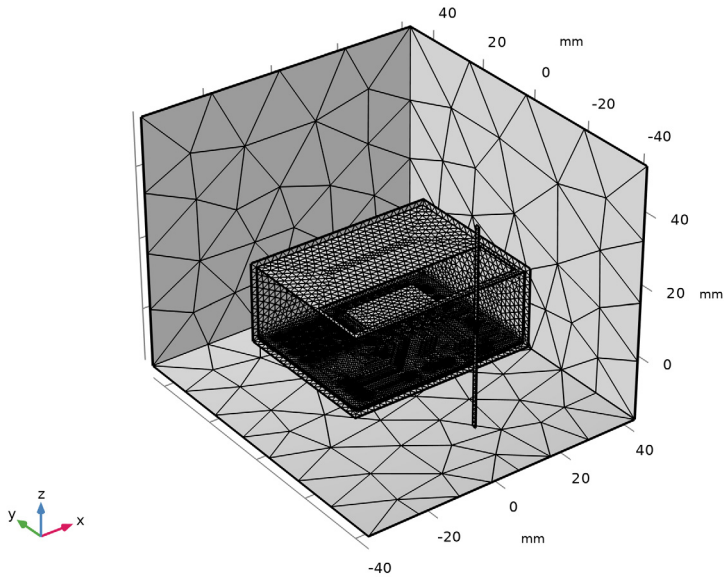

The first study is analyzing the emission from the circuit board, especially from a signal line.

STUDY 1 - EMISSION

- 1 In the **Model Builder** window, click **Study 1**.
- 2 In the **Settings** window for **Study**, type Study 1 - Emission in the **Label** text field.

Step 1: Frequency Domain

- 1 In the **Model Builder** window, under **Study 1 - Emission** click **Step 1: Frequency Domain**.
- 2 In the **Settings** window for **Frequency Domain**, locate the **Study Settings** section.
- 3 Click  **Range**.
- 4 In the **Range** dialog, type 2[GHz] in the **Start** text field.
- 5 In the **Step** text field, type 1[GHz].
- 6 In the **Stop** text field, type 6[GHz].
- 7 Click **Replace**.
- 8 In the **Settings** window for **Frequency Domain**, locate the **Physics and Variables Selection** section.

9 Select the **Modify model configuration for study step** checkbox.

The **Modify model configuration for study step** option allows you to disable unnecessary features and run the study. You do not need to address the antenna outside the enclosure at this time.

10 In the tree, select **Component 1 (comp1) > Electromagnetic Waves, Frequency Domain (emw) > Lumped Port 2**.

11 Click  **Disable**.

12 In the tree, select **Component 1 (comp1) > Electromagnetic Waves, Frequency Domain (emw) > Perfect Electric Conductor 2**.

13 Click  **Disable**.

14 In the **Study** toolbar, click  **Compute**.

let us modify the default plot.

RESULTS

Electric Field (emw)

1 In the **Model Builder** window, expand the **Results > Electric Field (emw)** node, then click **Electric Field (emw)**.

2 In the **Settings** window for **3D Plot Group**, locate the **Data** section.

3 From the **Parameter value (freq (GHz))** list, choose **5**.

Multislice 1

In the **Model Builder** window, right-click **Multislice 1** and choose **Delete**.

Electric Field (emw) - Circuit Board

In the **Settings** window for **3D Plot Group**, type **Electric Field (emw) - Circuit Board** in the **Label** text field.

Surface 1

Right-click **Electric Field (emw) - Circuit Board** and choose **Surface**.

Selection 1

1 In the **Model Builder** window, right-click **Surface 1** and choose **Selection**. The **Selection** subfeature let you plot the results only on the desired boundaries.

2 In the **Settings** window for **Selection**, locate the **Selection** section.

3 From the **Selection** list, choose **Printed layer**.

4 Click the  **Reset Hiding** button in the **Graphics** toolbar.

Surface 1

- 1 In the **Model Builder** window, click **Surface 1**.
- 2 In the **Settings** window for **Surface**, locate the **Expression** section.
- 3 In the **Expression** text field, type $20 * \log_{10}(emw.normE)$.
- 4 Locate the **Coloring and Style** section. From the **Color table** list, choose **HeatCameraLight**.

Deformation 1

- 1 Right-click **Surface 1** and choose **Deformation**.
Use the **Deformation** to emphasize the data plot or add more 3D look and feel.
- 2 In the **Settings** window for **Deformation**, locate the **Expression** section.
- 3 In the **X-component** text field, type 0.
- 4 In the **Y-component** text field, type 0.
- 5 In the **Z-component** text field, type $emw.normE$.
- 6 Locate the **Scale** section.
- 7 Select the **Scale factor** checkbox. In the associated text field, type $2e-4$.

Surface 2

Right-click **Surface 1** and choose **Duplicate**.

Selection 1

- 1 In the **Model Builder** window, expand the **Surface 2** node, then click **Selection 1**.
- 2 In the **Settings** window for **Selection**, locate the **Selection** section.
- 3 Click to select the **Activate Selection** toggle button.

4 Select Boundaries 11–13, 16, 18, 136, 137, 139, 140, 175, and 191 only.

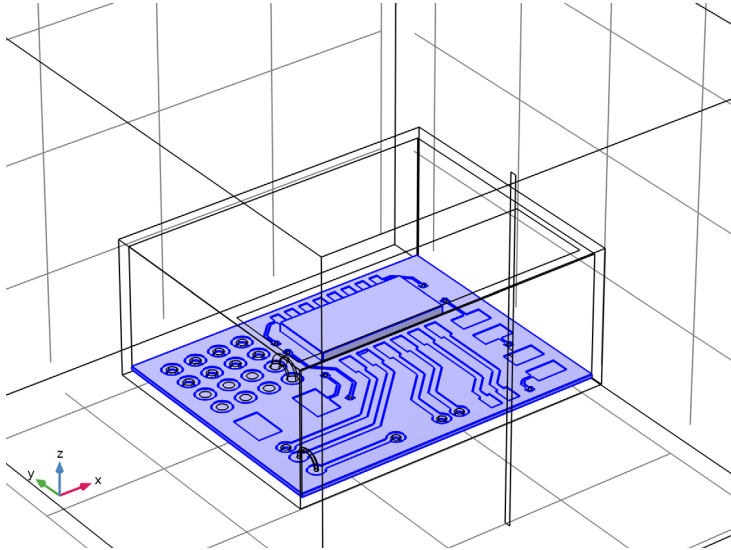

Surface 2

- 1 In the **Model Builder** window, click **Surface 2**.
- 2 In the **Settings** window for **Surface**, locate the **Coloring and Style** section.
- 3 From the **Color table** list, choose **AuroraAustralis**.
- 4 Clear the **Color legend** checkbox.

Surface 3

Right-click **Results > Electric Field (emw) - Circuit Board > Surface 2** and choose **Duplicate**.

Selection 1

- 1 In the **Model Builder** window, expand the **Surface 3** node, then click **Selection 1**.
- 2 In the **Settings** window for **Selection**, locate the **Selection** section.
- 3 Click to select the **Activate Selection** toggle button.

- 4 Select Boundaries 15, 17, 19, 20, and 192 only.

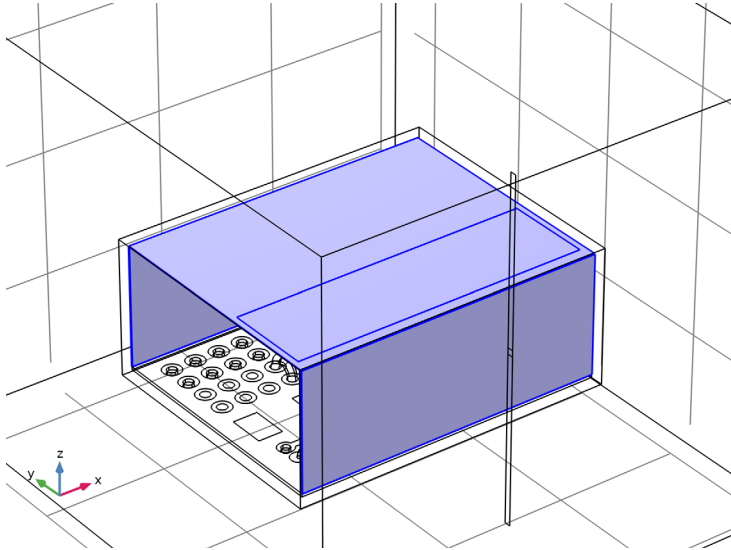

Surface 3

- 1 In the **Model Builder** window, click **Surface 3**.
- 2 In the **Settings** window for **Surface**, locate the **Coloring and Style** section.
- 3 From the **Color table** list, choose **Twilight**.
- 4 Clear the **Color legend** checkbox.

Transparency 1

- 1 Right-click **Surface 3** and choose **Transparency**. Using the **Transparency** subfeature, the plot can be partially transparent.
- 2 In the **Settings** window for **Transparency**, locate the **Transparency** section.
- 3 Find the **Transparency** subsection. Set the **Transparency** value to **0.6**.

Electric Field (emw) - Circuit Board

- 1 In the **Model Builder** window, under **Results** click **Electric Field (emw) - Circuit Board**.
- 2 In the **Settings** window for **3D Plot Group**, locate the **Plot Settings** section.
- 3 Clear the **Plot dataset edges** checkbox.

4 In the **Electric Field (emw) - Circuit Board** toolbar, click  **Plot**.

freq(4)=5 GHz Surface: 20*log10(emw.normE) Surface: 20*log10(emw.normE) Surface:
20*log10(emw.normE)

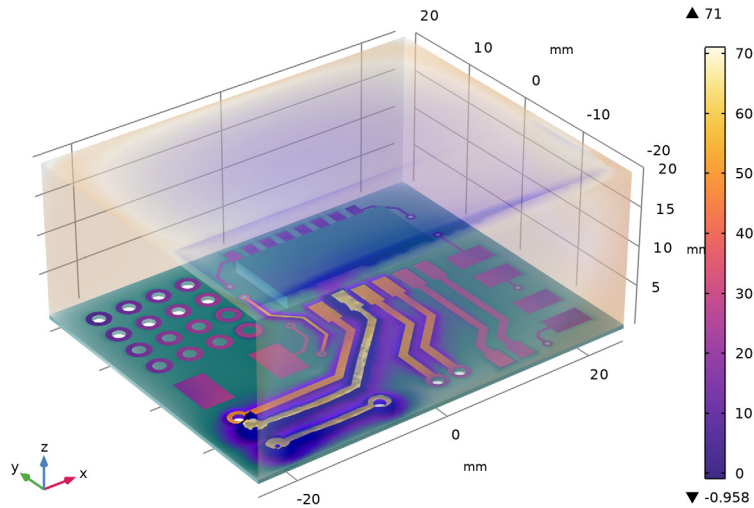

Surface 4

In the **Model Builder** window, under **Results > Electric Field (emw) - Circuit Board** right-click **Surface 1** and choose **Duplicate**.

Selection 1

- 1 In the **Model Builder** window, expand the **Surface 4** node, then click **Selection 1**.
- 2 In the **Settings** window for **Selection**, locate the **Selection** section.
- 3 From the **Selection** list, choose **Jumpers**.

Surface 4

- 1 In the **Model Builder** window, click **Surface 4**.
- 2 In the **Settings** window for **Surface**, click to expand the **Inherit Style** section.
- 3 From the **Plot** list, choose **Surface 1**.
- 4 In the **Electric Field (emw) - Circuit Board** toolbar, click  **Plot**.

Surface 5

Right-click **Results > Electric Field (emw) - Circuit Board > Surface 4** and choose **Duplicate**.

Selection 1

- 1 In the **Model Builder** window, expand the **Surface 5** node, then click **Selection 1**.
- 2 In the **Settings** window for **Selection**, locate the **Selection** section.
- 3 From the **Selection** list, choose **Vias**.
- 4 In the **Electric Field (emw) - Circuit Board** toolbar, click  **Plot**.

Line 1

- 1 In the **Model Builder** window, right-click **Electric Field (emw) - Circuit Board** and choose **Line**.
- 2 In the **Settings** window for **Line**, locate the **Coloring and Style** section.
- 3 From the **Color table** list, choose **Twilight**.
- 4 Clear the **Color legend** checkbox.

Selection 1

- 1 Right-click **Line 1** and choose **Selection**.
- 2 In the **Settings** window for **Selection**, locate the **Selection** section.
- 3 Click  **Paste Selection**.
- 4 In the **Paste Selection** dialog, type 9-32, 507, 527, 563, 659-670 in the **Selection** text field.

5 Click **OK**.

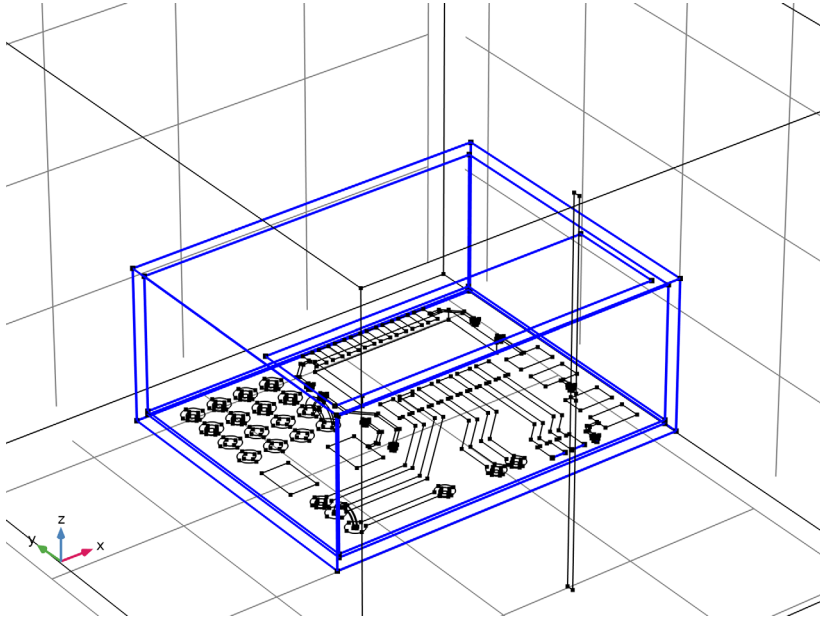

6 In the **Electric Field (emw) - Circuit Board** toolbar, click  **Plot**.

freq(4)=5 GHz Surface: $20 \cdot \log_{10}(\text{emw.normE})$ Surface: $20 \cdot \log_{10}(\text{emw.normE})$ Surface:
 $20 \cdot \log_{10}(\text{emw.normE})$ Surface: $20 \cdot \log_{10}(\text{emw.normE})$ Surface: $20 \cdot \log_{10}(\text{emw.normE})$ Line:
Electric field norm (V/m)

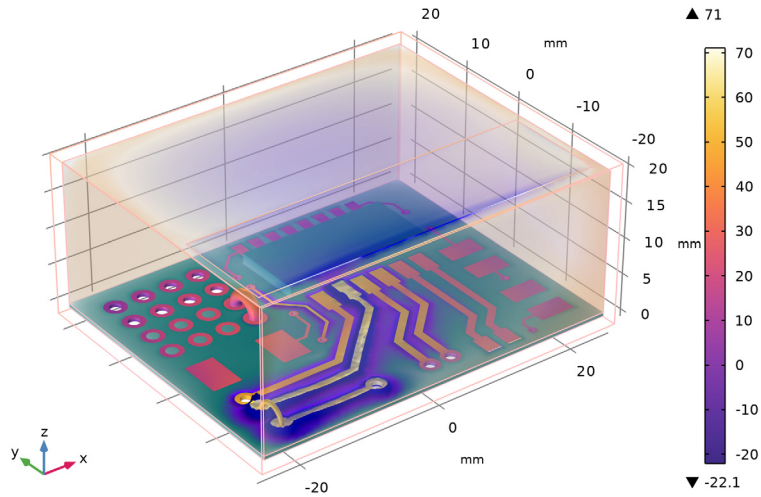

Electric Field, Logarithmic (emw)

In the **Model Builder** window, under **Results** click **Electric Field, Logarithmic (emw)**.

freq(5)=6 GHz Surface: 1 (1) Surface: 1 (1) Multislice: Electric field norm (V/m) Surface: Electric field norm (V/m)

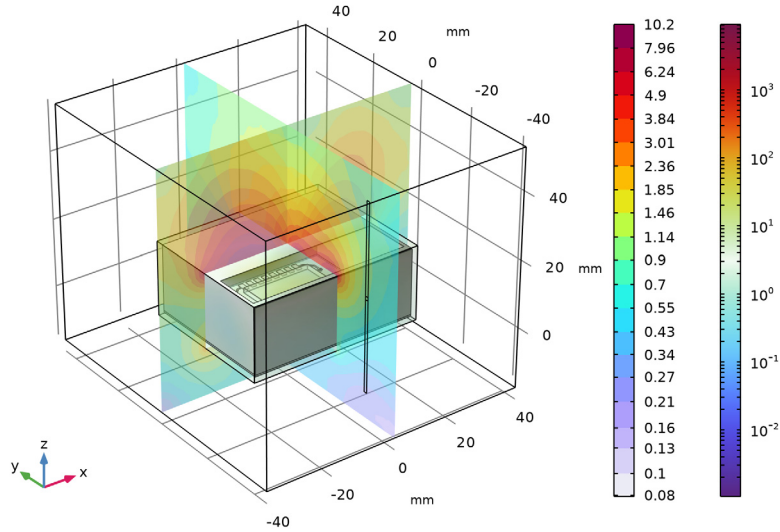

2D Far Field (emw)

A small amount of field is leaked through the slot on the top side of the enclosure. The far-field radiation pattern plot describes the directional field intensity.

1 In the **Model Builder** window, click **2D Far Field (emw)**.

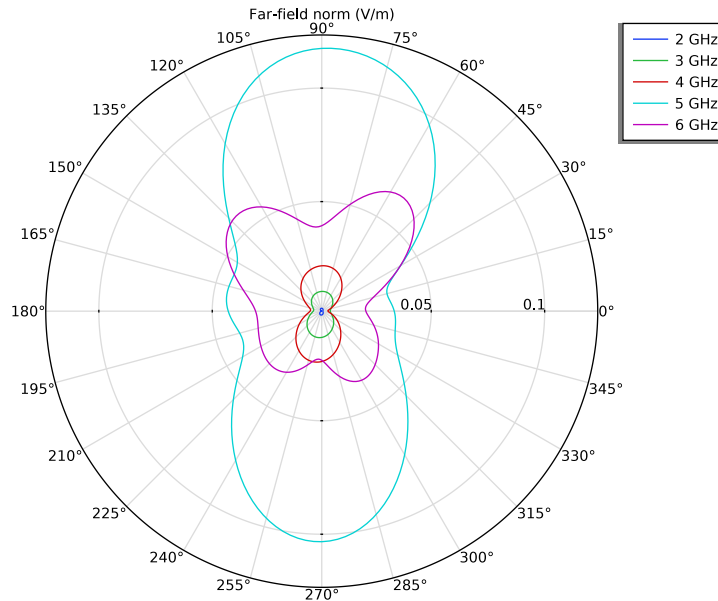

Radiation Pattern 1

- 1 In the **Model Builder** window, expand the **Results > 3D Far Field, Gain (emw)** node, then click **Radiation Pattern 1**.
- 2 In the **Settings** window for **Radiation Pattern**, locate the **Expression** section.
- 3 In the **Expression** text field, type `emw.normdBFar`.

Transparency 1

Right-click **Radiation Pattern 1** and choose **Transparency**. When 3D far-field radiation pattern is plotted, if it is added with the simulation model view, it often blocks the view. The **Transparency** can show the far-field pattern without hiding the other results plots.

3D Far Field, Gain (emw)

- 1 In the **Settings** window for **3D Plot Group**, locate the **Data** section.
- 2 From the **Parameter value (freq (GHz))** list, choose **5**.
- 3 Locate the **Plot Settings** section. Select the **Plot dataset edges** checkbox.
- 4 Click the  **Zoom Extents** button in the **Graphics** toolbar.

Volume 1

- 1 Right-click **3D Far Field, Gain (emw)** and choose **Volume**.

- 2 In the **Settings** window for **Volume**, locate the **Expression** section.
- 3 In the **Expression** text field, type $20 \cdot \log_{10}(\text{emw}.\text{normE})$.
- 4 Locate the **Coloring and Style** section. Clear the **Color legend** checkbox.
- 5 From the **Color table** list, choose **AuroraAustralis**.
- 6 From the **Color table transformation** list, choose **Reverse**.

Selection 1

- 1 Right-click **Volume 1** and choose **Selection**.
- 2 Select Domain 3 only.
- 3 In the **3D Far Field, Gain (emw)** toolbar, click  **Plot**.

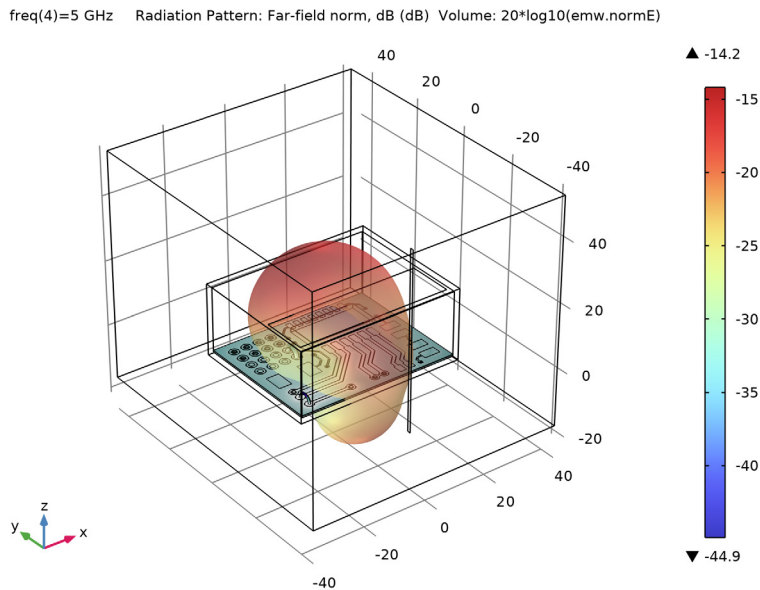

Radiated Emission - Near Field

- 1 In the **Results** toolbar, click  **3D Plot Group**.
- 2 In the **Settings** window for **3D Plot Group**, type Radiated Emission - Near Field in the **Label** text field.
- 3 Locate the **Color Legend** section. Select the **Show maximum and minimum values** checkbox.

Surface 1

- 1 Right-click **Radiated Emission - Near Field** and choose **Surface**.

- 2 Click the  **Zoom Extents** button in the **Graphics** toolbar.

Selection 1

- 1 In the **Model Builder** window, right-click **Surface 1** and choose **Selection**.
- 2 Select Boundaries 1–5 and 189 only.

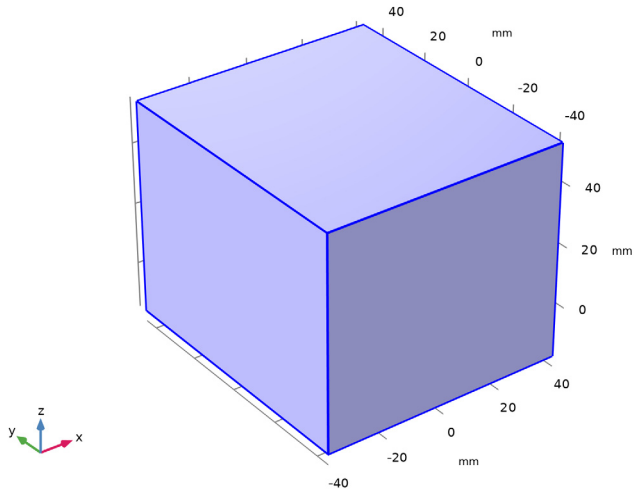



Surface 1

- 1 In the **Model Builder** window, click **Surface 1**.
- 2 In the **Settings** window for **Surface**, locate the **Coloring and Style** section.
- 3 From the **Color table** list, choose **Twilight**.

Review the leaked field at each simulated frequency.

Radiated Emission - Near Field

- 1 In the **Model Builder** window, click **Radiated Emission - Near Field**.
- 2 In the **Settings** window for **3D Plot Group**, click  **Plot First**. This plots the result at 2GHz.

3 Click the  **Transparency** button in the **Graphics** toolbar.

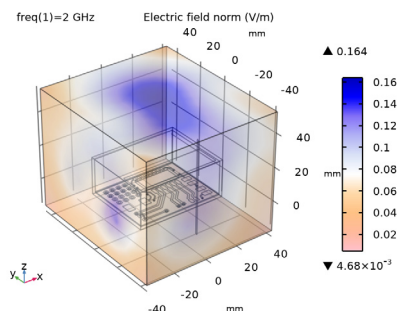

4 Click  **Plot Next**. This plots the result at 3GHz.

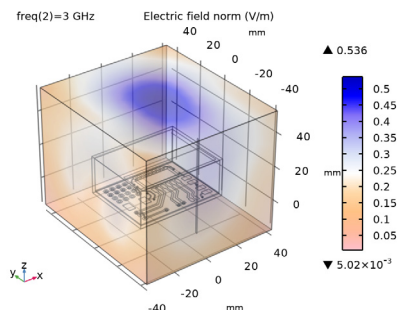

5 Click  **Plot Next**. This plots the result at 4GHz.

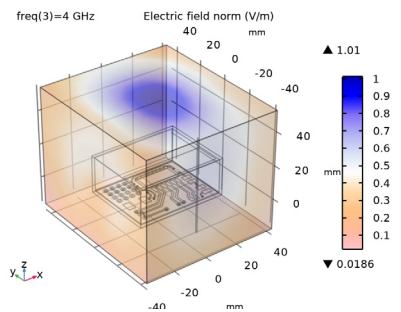

6 Click **Plot Next**. This plots the result at 5GHz.

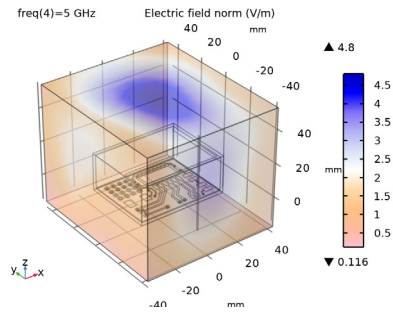

7 Click **Plot Next**. This plots the result at 6GHz.

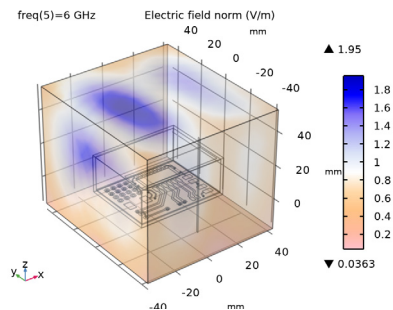

8 Click the  **Transparency** button in the **Graphics** toolbar.

Plot the power leakage ratio with respect to the time-averaged input power to the signal line.

Power Leakage

- 1 In the **Results** toolbar, click  **ID Plot Group**.
- 2 In the **Settings** window for **ID Plot Group**, type Power Leakage in the **Label** text field.
- 3 Click to expand the **Title** section. From the **Title type** list, choose **Manual**.
- 4 In the **Title** text area, type Power Leakage (%).
- 5 Locate the **Legend** section. Clear the **Show legends** checkbox.

Global 1

- 1 Right-click **Power Leakage** and choose **Global**.
- 2 In the **Settings** window for **Global**, locate the **y-Axis Data** section.

3 In the table, enter the following settings:

Expression	Unit	Description
$\text{power_leaked}/\text{power_input}$	%	

4 In the **Power Leakage** toolbar, click  **Plot**.

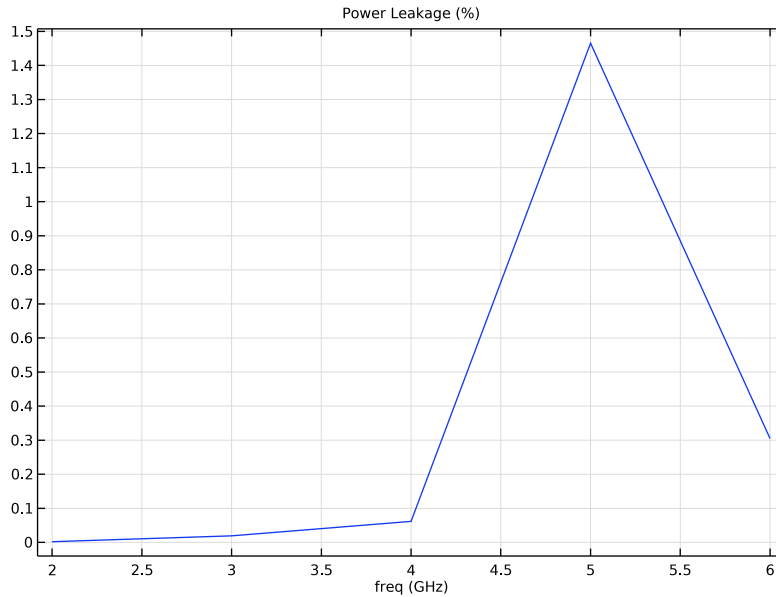

Plot the crosstalk ratio between the coupled power to the adjacent line and the time-averaged input power to the signal line.

Crosstalk to Adjacent Line

- 1 In the **Results** toolbar, click  **ID Plot Group**.
- 2 In the **Settings** window for **ID Plot Group**, type Crosstalk to Adjacent Line in the **Label** text field.
- 3 Click to expand the **Title** section. From the **Title type** list, choose **Manual**.
- 4 In the **Title** text area, type Crosstalk (%).
- 5 Locate the **Legend** section. Clear the **Show legends** checkbox.

Global 1

- 1 Right-click **Crosstalk to Adjacent Line** and choose **Global**.
- 2 In the **Settings** window for **Global**, locate the **y-Axis Data** section.

3 In the table, enter the following settings:

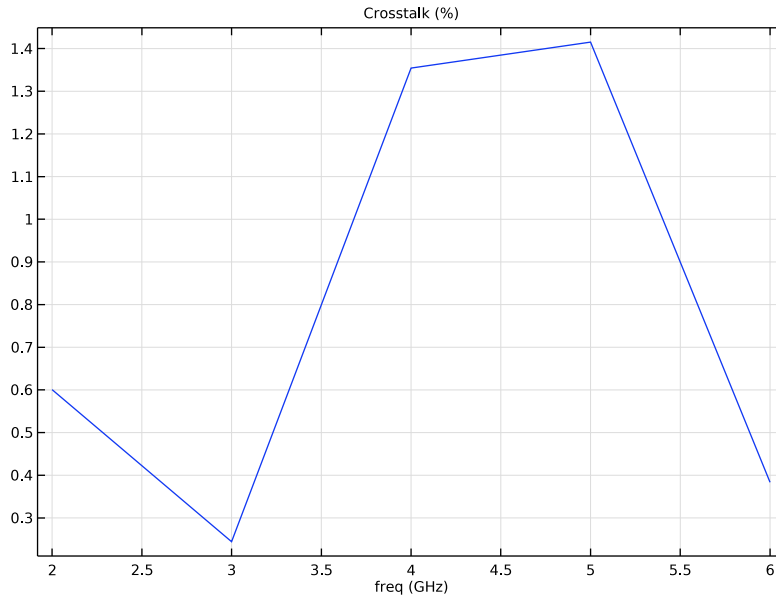

Expression	Unit	Description
<code>abs(emw.Pelement_2)/power_input</code>	%	

4 In the **Crosstalk to Adjacent Line** toolbar, click  **Plot**.



The emission analysis from the circuit board inside an enclosure with a small window is finished. The next study assumes the noise source is located outside the enclosure. You will see the impact on the circuit board.

ADD STUDY

- 1 In the **Home** toolbar, click  **Add Study** to open the **Add Study** window.
- 2 Go to the **Add Study** window.
- 3 Find the **Studies** subsection. In the **Select Study** tree, select **General Studies** > **Frequency Domain**.
- 4 Click the **Add Study** button in the window toolbar.
- 5 In the **Home** toolbar, click  **Add Study** to close the **Add Study** window.

STUDY 2 - IMMUNITY

- 1 In the **Settings** window for **Study**, type Study 2 - Immunity in the **Label** text field.

- 2 Locate the **Study Settings** section. Clear the **Generate default plots** checkbox. The default plots will not be generated. Instead, some of the plots from the first study will be duplicated after computation.

Step 1: Frequency Domain



- 1 In the **Model Builder** window, under **Study 2 - Immunity** click **Step 1: Frequency Domain**.
- 2 In the **Settings** window for **Frequency Domain**, locate the **Study Settings** section.
- 3 In the **Frequencies** text field, type `range(2[GHz], 1[GHz], 6[GHz])`.
- 4 Locate the **Physics and Variables Selection** section. Select the **Modify model configuration for study step** checkbox.
- 5 In the tree, select **Component 1 (comp1) > Electromagnetic Waves, Frequency Domain (emw) > Lumped Port 1**.
- 6 Right-click and choose **Disable**.
- 7 In the tree, select **Component 1 (comp1) > Electromagnetic Waves, Frequency Domain (emw) > Far-Field Domain 1**.
- 8 Right-click and choose **Disable**.

In this study, there is no excitation source in the circuit board. Though the printed dipole antenna is activated, the far-field analysis of the antenna is not of interest.

- 9 In the **Home** toolbar, click  **Compute**.

RESULTS

Electric Field (emw) - Circuit Board, Immunity

- 1 In the **Model Builder** window, right-click **Electric Field (emw) - Circuit Board** and choose **Duplicate**.
- 2 In the **Settings** window for **3D Plot Group**, type `Electric Field (emw) - Circuit Board, Immunity` in the **Label** text field.
- 3 Locate the **Data** section. From the **Dataset** list, choose **Study 2 - Immunity/Solution 2 (sol2)**.
- 4 Click the  **Zoom Extents** button in the **Graphics** toolbar.
- 5 In the **Electric Field (emw) - Circuit Board, Immunity** toolbar, click  **Plot**.
- 6 In the **Model Builder** window, expand the **Electric Field (emw) - Circuit Board, Immunity** node.

Deformation 1

- 1 In the **Model Builder** window, expand the **Results > Electric Field (emw) - Circuit Board, Immunity > Surface 1** node, then click **Deformation 1**.

- 2 In the **Settings** window for **Deformation**, locate the **Scale** section.
- 3 In the **Scale factor** text field, type $4e-3$.

Deformation 1

- 1 In the **Model Builder** window, expand the **Results > Electric Field (emw) - Circuit Board, Immunity > Surface 2** node, then click **Deformation 1**.
- 2 In the **Settings** window for **Deformation**, locate the **Scale** section.
- 3 In the **Scale factor** text field, type $4e-3$.
- 4 In the **Electric Field (emw) - Circuit Board, Immunity** toolbar, click  **Plot**. This plot describes the field strength coupled to the circuit board and interior walls of the enclosure from the radiation of the printed dipole antenna.

freq(4)=5 GHz Surface: $20 \cdot \log_{10}(\text{emw.normE})$ Surface: $20 \cdot \log_{10}(\text{emw.normE})$ Surface: $20 \cdot \log_{10}(\text{emw.normE})$
 20* $\log_{10}(\text{emw.normE})$ Surface: $20 \cdot \log_{10}(\text{emw.normE})$ Surface: $20 \cdot \log_{10}(\text{emw.normE})$ Line:
 Electric field norm (V/m)

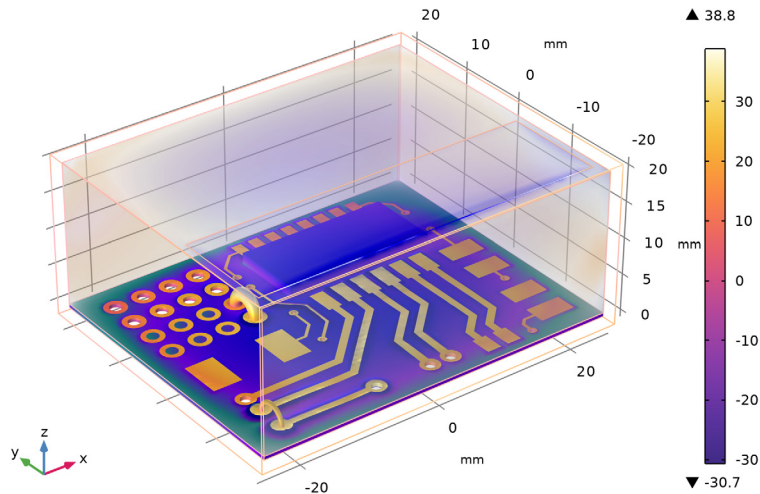

Plot the coupling ratio between the coupled power to the adjacent line and the time-averaged input power to the printed dipole antenna.

Noise Coupling to Signal Line

- 1 In the **Model Builder** window, right-click **Crosstalk to Adjacent Line** and choose **Duplicate**.
- 2 In the **Settings** window for **ID Plot Group**, type Noise Coupling to Signal Line in the **Label** text field.

- 3 Locate the **Data** section. From the **Dataset** list, choose **Study 2 - Immunity/Solution 2 (sol2)**.

Global 1

- 1 In the **Model Builder** window, expand the **Noise Coupling to Signal Line** node, then click **Global 1**.
- 2 In the **Settings** window for **Global**, locate the **y-Axis Data** section.
- 3 In the table, enter the following settings:

Expression	Unit	Description
$\text{abs}(\text{emw.Pelement}_1) / \text{power_input}$	%	

- 4 In the **Noise Coupling to Signal Line** toolbar, click  **Plot**.

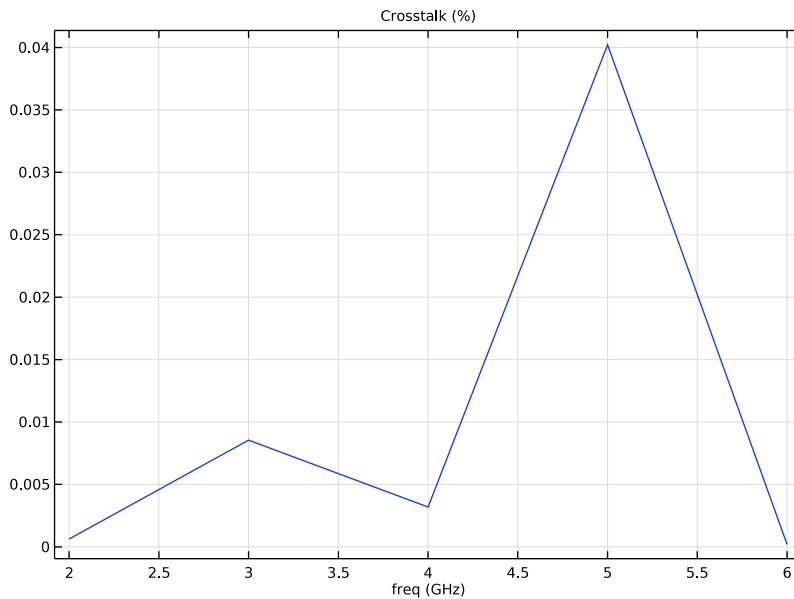

In both studies, it is observed that the strongest coupled field, crosstalk, and radiation happen around 5GHz even when the printed dipole antenna is supposed to be better for the Wi-Fi frequency.

GLOBAL DEFINITIONS

Parameters I

The parameter table can be used as a simple calculator. Calculate the dominant resonant frequency of a closed cavity based on the dimension of the interior walls.

- 1 In the **Model Builder** window, under **Global Definitions** click **Parameters I**.
- 2 In the **Settings** window for **Parameters**, locate the **Parameters** section.
- 3 In the table, enter the following settings:

Name	Expression	Value	Description
f_TE101	$\sqrt{(\pi/50[\text{mm}])^2 + (\pi/40[\text{mm}])^2} / (2 * \pi * \sqrt{\mu_0_const * \epsilon_0_const})$	4.799E9 1/s	TE101 mode cavity resonant frequency

The computed resonant frequency is about 4.8 GHz. So the given structure makes the circuit and environment vulnerable around the cavity resonance though the noise source might be stronger at a different frequency.