



Model created in COMSOL Multiphysics 6.4

Modeling a Biconical Antenna for EMI/EMC Testing

Introduction

Biconical antennas are popular for very high frequency (VHF) measurement because they support a wide frequency range. They are also useful for electromagnetic compatibility (EMC) testing where the antenna can be used as an RF source in susceptibility or immunity test. This example simulates a biconical antenna made of lightweight hexagonal frames that are preferred over solid cones for fabrication. The simulation includes the computation of far-field radiation pattern and voltage standing wave ratio (VSWR).

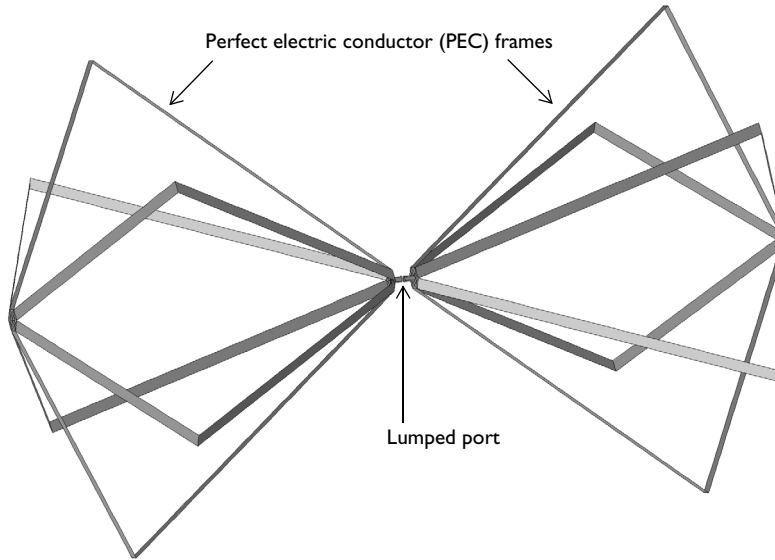

Figure 1: The frames of a biconical antenna are modeled as boundaries. The surrounding air domain and perfectly matched layers, which are required for the simulation, are not included in this figure.

Note: This example requires the RF Module and the Design Module.

Model Definition

The operating frequency of this example is in the conventional VHF frequency range from 60 MHz to 240 MHz. To simplify modeling steps and reduce the required computational resources, first, assume that the antenna frame structure is geometrically flat and very thin.

However, the thickness is greater than the skin depth in the given frequency range so it is reasonable to model it as a perfect electric conductor.

A lumped port with a 50Ω reference impedance is assigned to the gap located at the center of the two structures composed of hexagonal frames; lumped ports should be applied between two conducting boundaries.

The antenna is enclosed by a spherical air domain. The outermost layers of the air domain are configured as perfectly matched layers (PML) that absorb all outgoing radiation from the antenna and work as an anechoic chamber during the simulation.

Results and Discussion

[Figure 2](#) presents the electric field distribution in dB, as well as an arrow plot showing the directional properties of the field at 70 MHz. It is observed that the electric field is confined to the entire structure when the frequency is in the lower range and the reacting area is gradually changed as the frequency increases.

The 2D far-field polar plot is visualized in [Figure 3](#). The antenna is aligned along the z -axis and the radiation pattern is omnidirectional in the xy -plane. The 3D far-field radiation pattern in [Figure 4](#) shows the same omnidirectional characteristics in the azimuthal direction. The computed VSWR ([Figure 5](#)) is approximately 3:1 on average.

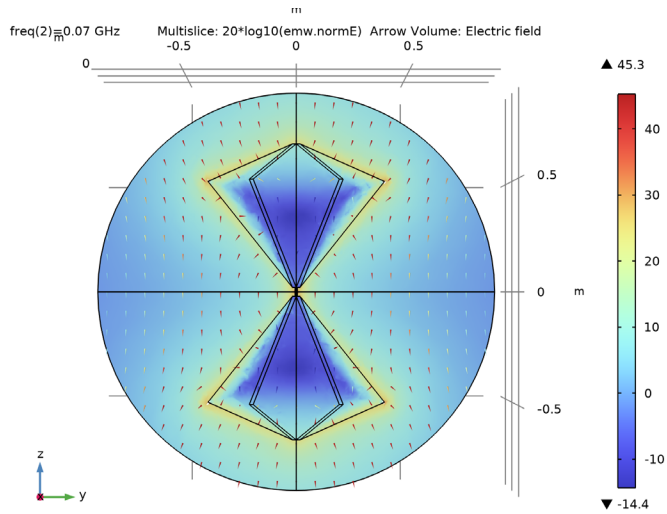

Figure 2: Electric field distribution on the yz -plane in dB at 70 MHz. The electric field is resonant over the entire antenna structure.

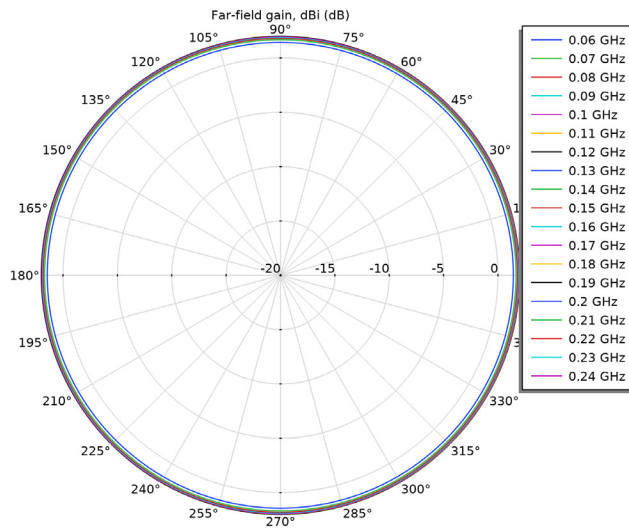

Figure 3: Polar far-field plot on the xy -plane. The overall antenna gain is around 0 dBi.

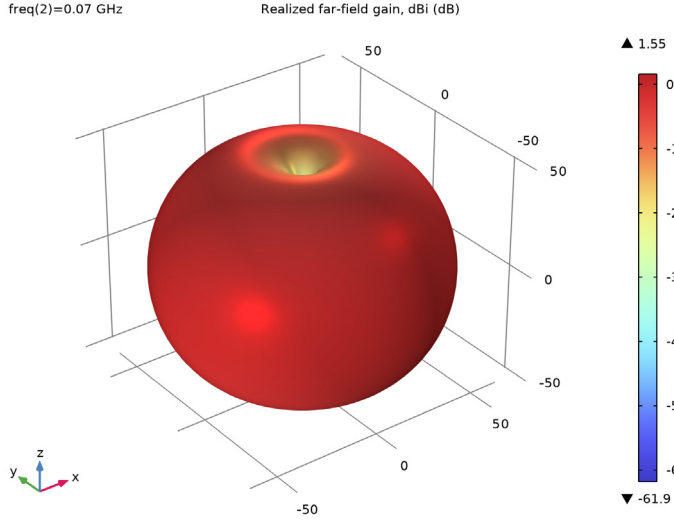

Figure 4: 3D far-field pattern at 70 MHz. The pattern resembles that of a typical half-wave dipole antenna.

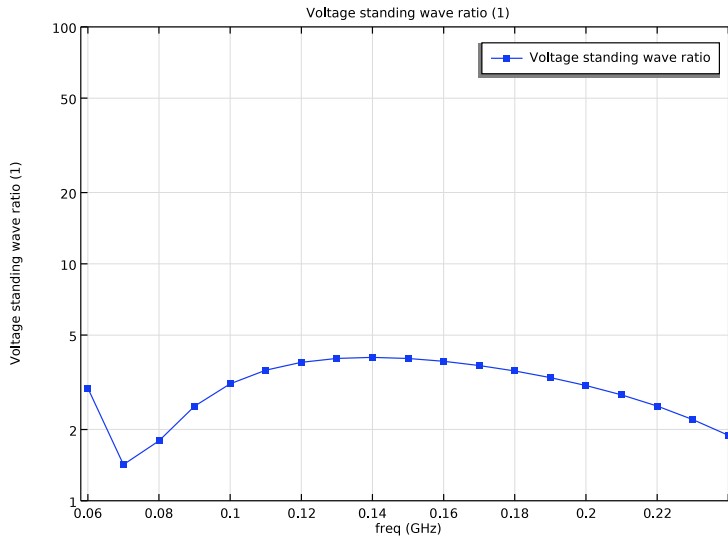



Figure 5: Voltage standing wave ratio (VSWR) plot with a log scale on the y-axis. It presents approximately a VSWR of 3:1 on average.

Application Library path: RF_Module/Antennas/biconical_frame_antenna



Modeling Instructions

From the **File** menu, choose **New**.

NEW

In the **New** window, click  **Model Wizard**.

MODEL WIZARD

- 1 In the **Model Wizard** window, click  **3D**.
- 2 In the **Select Physics** tree, select **Radio Frequency > Electromagnetic Waves, Frequency Domain (emw)**.
- 3 Click **Add**.
- 4 Click  **Study**.
- 5 In the **Select Study** tree, select **General Studies > Frequency Domain**.
- 6 Click  **Done**.

STUDY I

Step 1: Frequency Domain

Define the study frequency ahead of performing any frequency-dependent operation such as building mesh. The physics-controlled mesh uses the highest frequency value in the specified range.

- 1 In the **Model Builder** window, under **Study I** click **Step 1: Frequency Domain**.
- 2 In the **Settings** window for **Frequency Domain**, locate the **Study Settings** section.
- 3 In the **Frequencies** text field, type range (60[MHz], 10[MHz], 240[MHz]).

GEOMETRY I

- 1 In the **Model Builder** window, under **Component 1 (comp1)** click **Geometry 1**.
- 2 In the **Settings** window for **Geometry**, locate the **Advanced** section.
- 3 From the **Geometry representation** list, choose **CAD kernel**.

Work Plane 1 (wp1)



- 1 In the **Geometry** toolbar, click  **Work Plane**.

- 2 In the **Settings** window for **Work Plane**, locate the **Plane Definition** section.
- 3 In the **z-coordinate** text field, type 2[cm].

Work Plane 1 (wp1) > Plane Geometry

In the **Model Builder** window, click **Plane Geometry**.



Work Plane 1 (wp1) > Rectangle 1 (r1)

- 1 In the **Work Plane** toolbar, click  **Rectangle**.
- 2 In the **Settings** window for **Rectangle**, locate the **Size and Shape** section.
- 3 In the **Width** text field, type 2[cm].
- 4 In the **Height** text field, type $2[\text{cm}]/2*\text{sqrt}(3)$.
- 5 Locate the **Position** section. In the **xw** text field, type -1[cm].
- 6 Click  **Build Selected**.

Work Plane 2 (wp2)

- 1 In the **Model Builder** window, right-click **Geometry 1** and choose **Work Plane**.
- 2 In the **Settings** window for **Work Plane**, locate the **Plane Definition** section.
- 3 In the **z-coordinate** text field, type 50[cm].
- 4 Click  **Go to Plane Geometry**.

Work Plane 2 (wp2) > Rectangle 1 (r1)

- 1 In the **Work Plane** toolbar, click  **Rectangle**.
- 2 In the **Settings** window for **Rectangle**, locate the **Size and Shape** section.
- 3 In the **Width** text field, type 2[cm].
- 4 In the **Height** text field, type 40[cm].
- 5 Locate the **Position** section. In the **xw** text field, type -1[cm].
- 6 Click  **Build Selected**.

Copy 1 (copy1)

- 1 Right-click **Geometry 1** and choose **Transforms > Copy**.
- 2 Select the object **wp1** only.
- 3 In the **Settings** window for **Copy**, locate the **Displacement** section.
- 4 In the **z** text field, type 0.65.
- 5 Click  **Build Selected**.

6 Click the  **Zoom Extents** button in the **Graphics** toolbar.

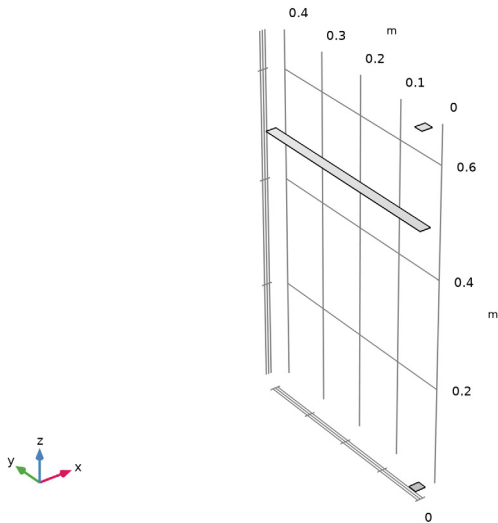

Loft 1 (loft1)

- 1 In the **Geometry** toolbar, click  **Loft**.
- 2 Select the objects **wp1** and **wp2** only.

Loft 2 (loft2)

- 1 In the **Geometry** toolbar, click  **Loft**.
- 2 In the **Settings** window for **Loft**, click to expand the **Start Profile** section.
- 3 Click to select the **Activate Selection** toggle button for **Start profile**.

4 On the object **loft1**, select Boundary 4 only.

It might be easier to select the correct boundary by using the **Selection List** window. To open this window, in the **Home** toolbar click **Windows** and choose **Selection List**. (If you are running the cross-platform desktop, you find **Windows** in the main menu.)

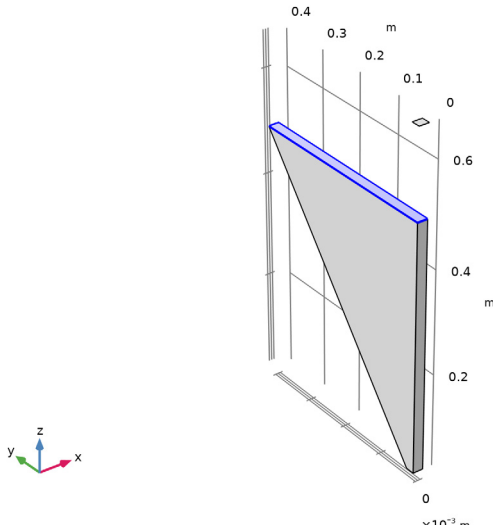

5 Click to expand the **End Profile** section. Click to select the **Activate Selection** toggle button for **End profile**.

6 On the object **copy1**, select Boundary 1 only.

7 Click the  **Wireframe Rendering** button in the **Graphics** toolbar.

Delete Entities 1 (dell)

- 1 Right-click **Geometry 1** and choose **Delete Entities**.

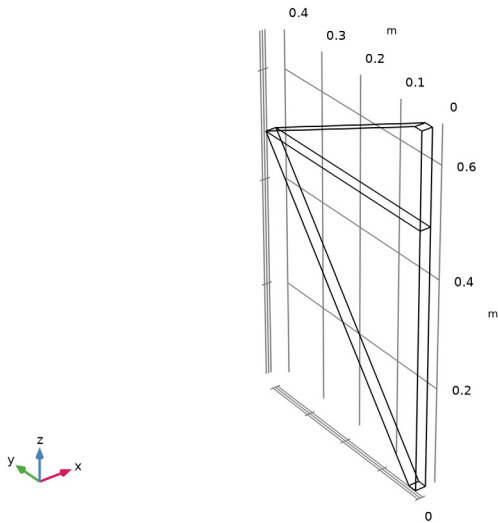

- 2 On the object **loft2**, select Boundaries 1, 2, 4–6, 10, and 11 only.
- 3 In the **Settings** window for **Delete Entities**, click  **Build Selected**.

Rotate 1 (rot1)

- 1 In the **Geometry** toolbar, click  **Transforms** and choose **Rotate**.
- 2 Select the object **dell** only.
- 3 In the **Settings** window for **Rotate**, locate the **Rotation** section.
- 4 In the **Angle** text field, type 0 60 120 180 240 300.

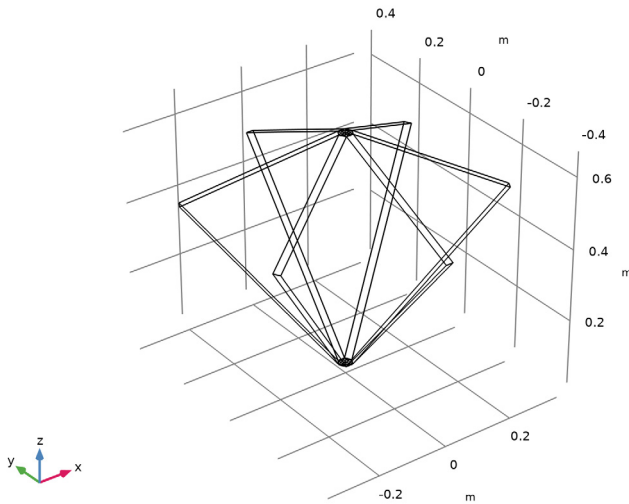

5 Click  **Build Selected**.



Cylinder 1 (cyl1)

- 1 In the **Geometry** toolbar, click  **Cylinder**.
- 2 In the **Settings** window for **Cylinder**, locate the **Size and Shape** section.
- 3 In the **Radius** text field, type 5[mm].
- 4 In the **Height** text field, type 17.5[mm].
- 5 Locate the **Position** section. In the **z** text field, type 2.5[mm].

Rotate 2 (rot2)

- 1 In the **Geometry** toolbar, click  **Transforms** and choose **Rotate**.
- 2 Click the  **Select All** button in the **Graphics** toolbar.
- 3 In the **Settings** window for **Rotate**, locate the **Rotation** section.
- 4 In the **Angle** text field, type 0 180.
- 5 From the **Axis type** list, choose **x-axis**.
- 6 Locate the **Selections of Resulting Entities** section. Find the **Cumulative selection** subsection. Click **New**.
- 7 In the **New Cumulative Selection** dialog, By creating the selection of resulting entities, you can easily choose the all antenna radiator surfaces when setting up the physics later on.
- 8 type Antenna frame in the **Name** text field.

9 Click **OK**.

10 In the **Settings** window for **Rotate**, click  **Build Selected**.

11 Click the  **Zoom Extents** button in the **Graphics** toolbar.

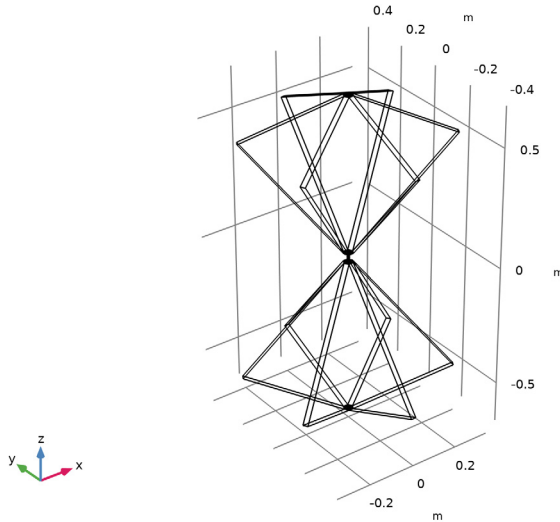

Work Plane 3 (wp3)

1 In the **Geometry** toolbar, click  **Work Plane**.

2 In the **Settings** window for **Work Plane**, locate the **Plane Definition** section.

3 From the **Plane** list, choose **zx-plane**.

4 Click  **Go to Plane Geometry**.

Work Plane 3 (wp3) > Plane Geometry

Click the  **Zoom In** button in the **Graphics** toolbar, a few of times to get a view.

Work Plane 3 (wp3) > Rectangle 1 (r1)

1 In the **Work Plane** toolbar, click  **Rectangle**.

2 In the **Settings** window for **Rectangle**, locate the **Size and Shape** section.

3 In the **Width** text field, type 5[mm].

4 In the **Height** text field, type 10[mm].

5 Locate the **Position** section. In the **xw** text field, type -2.5[mm].

6 In the **yw** text field, type -5[mm].

7 Click  **Build Selected**.

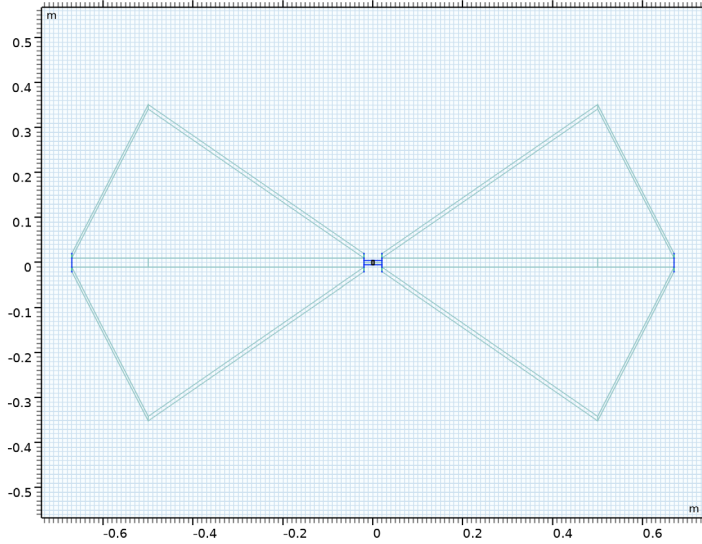

Sphere 1 (sph1)

- 1 Right-click **Geometry 1** and choose **Sphere**.
- 2 In the **Settings** window for **Sphere**, locate the **Size** section.
- 3 In the **Radius** text field, type 1.2.
- 4 Click to expand the **Layers** section. In the table, enter the following settings:

Layer name	Thickness (m)
Layer 1	0.3

- 5 In the **Geometry** toolbar, click  **Build All**.

6 In the **Model Builder** window, click **Geometry 1**.

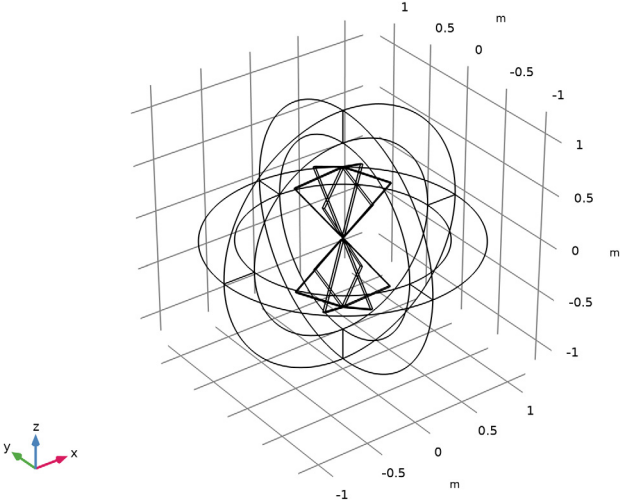

DEFINITIONS

Perfectly Matched Layer 1 (pml1)

1 In the **Definitions** toolbar, click  **Perfectly Matched Layer**.

2 Select Domains 1–4 and 8–11 only.

These are all of the outermost domains of the sphere.

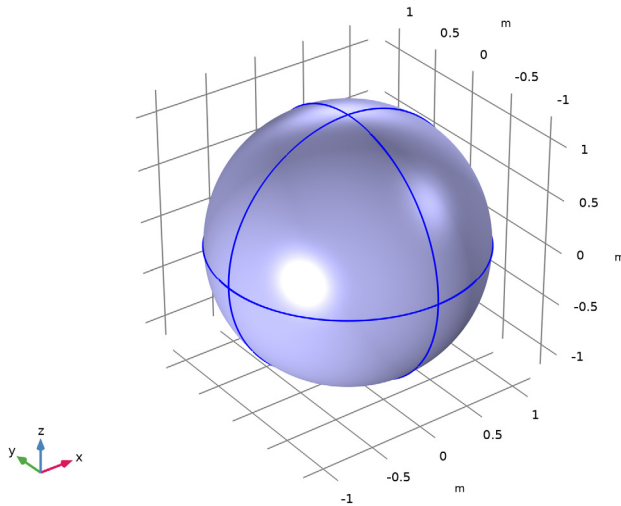

3 In the **Settings** window for **Perfectly Matched Layer**, locate the **Geometry** section.

4 From the **Type** list, choose **Spherical**.

Suppress some boundaries to get a better view when setting up materials, physics and mesh.

Hide for Physics 1

1 In the **Model Builder** window, right-click **View 1** and choose **Hide for Physics**.

2 In the **Settings** window for **Hide for Physics**, locate the **Geometric Entity Selection** section.

3 From the **Geometric entity level** list, choose **Boundary**.

4 Select Boundaries 1, 5, 6, 9, 10, and 90–96 only.

ADD MATERIAL

1 In the **Materials** toolbar, click  **Add Material** to open the **Add Material** window.

2 Go to the **Add Material** window.

3 In the tree, select **Built-in > Air**.

4 Click the **Add to Component** button in the window toolbar.

5 In the **Materials** toolbar, click  **Add Material** to close the **Add Material** window.



ELECTROMAGNETIC WAVES, FREQUENCY DOMAIN (EMW)

Perfect Electric Conductor 2

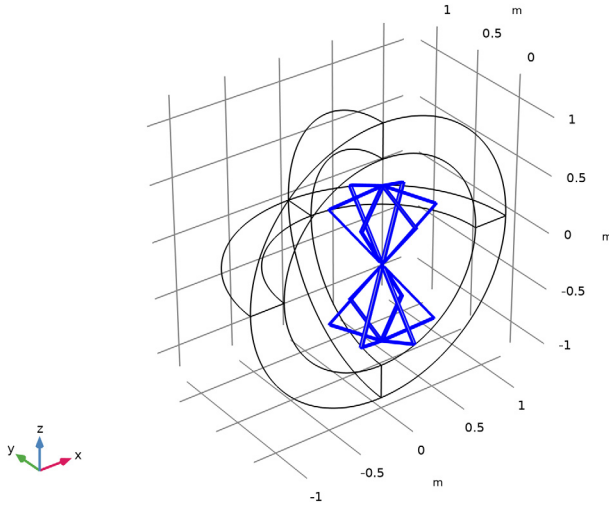
- 1 In the **Physics** toolbar, click  **Boundaries** and choose **Perfect Electric Conductor**.
- 2 In the **Settings** window for **Perfect Electric Conductor**, locate the **Boundary Selection** section.
- 3 From the **Selection** list, choose **Antenna frame**.



Lumped Port 1

- 1 In the **Physics** toolbar, click  **Boundaries** and choose **Lumped Port**.
- 2 Click the  **Zoom In** button in the **Graphics** toolbar, a few of times to get a view.

3 Select Boundary 73 only.

For the first port, wave excitation is **on** by default.

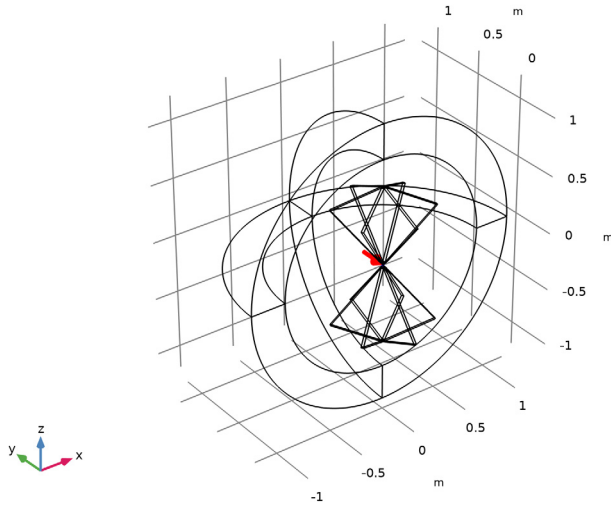

Far-Field Domain I

In the **Physics** toolbar, click  **Domains** and choose **Far-Field Domain**.

MESH I

- 1 In the **Model Builder** window, under **Component I (comp1)** click **Mesh I**.
- 2 In the **Settings** window for **Mesh**, locate the **Physics-Controlled Mesh** section.
- 3 In the table, clear the **Use** checkbox for **Geometric Analysis, Detail Size**.

4 Click  **Build All**.

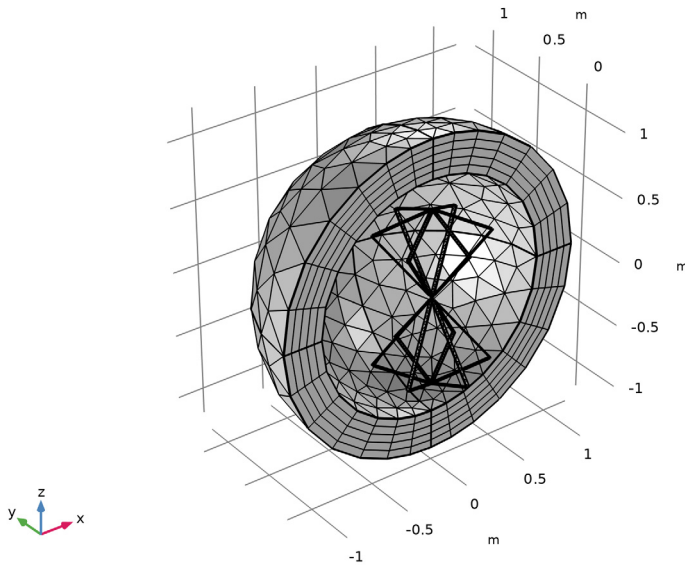

STUDY 1

Step 1: Frequency Domain

In the **Study** toolbar, click  **Compute**.

RESULTS

Electric Field (emw)

The electric field distribution inside the PMLs is not of interest, so remove the PML domains from the visualization.

1 In the **Model Builder** window, expand the **Results > Datasets** node.

Multislice 1

Adjust the default E-field norm multislice plot.

1 In the **Model Builder** window, expand the **Electric Field (emw)** node, then click **Multislice 1**.

2 In the **Settings** window for **Multislice**, locate the **Expression** section.

3 In the **Expression** text field, type $20 * \log_{10}(\text{emw}.\text{normE})$.

- 4 Locate the **Multipane Data** section. Find the **Y-planes** subsection. In the **Planes** text field, type 0.
- 5 Find the **Z-planes** subsection. In the **Planes** text field, type 0.
- 6 In the **Electric Field (emw)** toolbar, click  **Plot**.

Electric Field (emw)

Add an arrow plot.



Arrow Volume 1

- 1 In the **Model Builder** window, right-click **Electric Field (emw)** and choose **Arrow Volume**.
- 2 In the **Settings** window for **Arrow Volume**, locate the **Arrow Positioning** section.
- 3 Find the **X grid points** subsection. In the **Points** text field, type 1.
- 4 Find the **Y grid points** subsection. In the **Points** text field, type 21.
- 5 Find the **Z grid points** subsection. In the **Points** text field, type 21.
- 6 Locate the **Coloring and Style** section. From the **Arrow type** list, choose **Cone**.
- 7 From the **Arrow length** list, choose **Normalized**.
- 8 Select the **Scale factor** checkbox. In the associated text field, type $2e-4$.

Color Expression 1

- 1 Right-click **Arrow Volume 1** and choose **Color Expression**.
- 2 In the **Settings** window for **Color Expression**, locate the **Expression** section.
- 3 In the **Expression** text field, type $20 * \log_{10}(emw.normE)$.
- 4 Locate the **Coloring and Style** section. Clear the **Color legend** checkbox.
- 5 Click to expand the **Range** section. Select the **Manual color range** checkbox.
- 6 In the **Maximum** text field, type 5.

Electric Field (emw)

- 1 In the **Model Builder** window, under **Results** click **Electric Field (emw)**.
- 2 In the **Settings** window for **3D Plot Group**, locate the **Data** section.
- 3 From the **Parameter value (freq (GHz))** list, choose **0.07**.
- 4 In the **Electric Field (emw)** toolbar, click  **Plot**.
- 5 Click the  **Go to YZ View** button in the **Graphics** toolbar.

See [Figure 2](#) for the reproduced plot.

S-Parameter (emw)

In the **Model Builder** window, click **S-Parameter (emw)**.

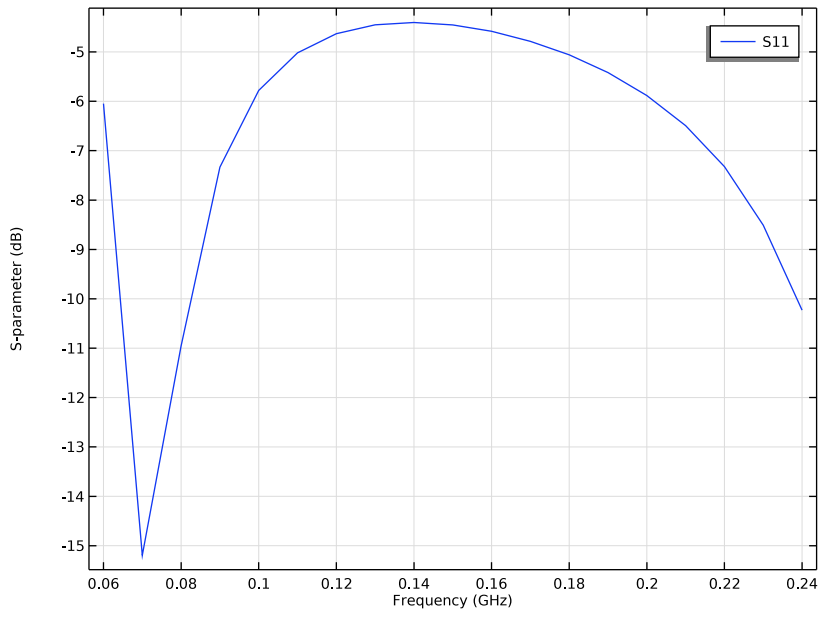

Smith Plot (emw)

In the **Model Builder** window, click **Smith Plot (emw)**.

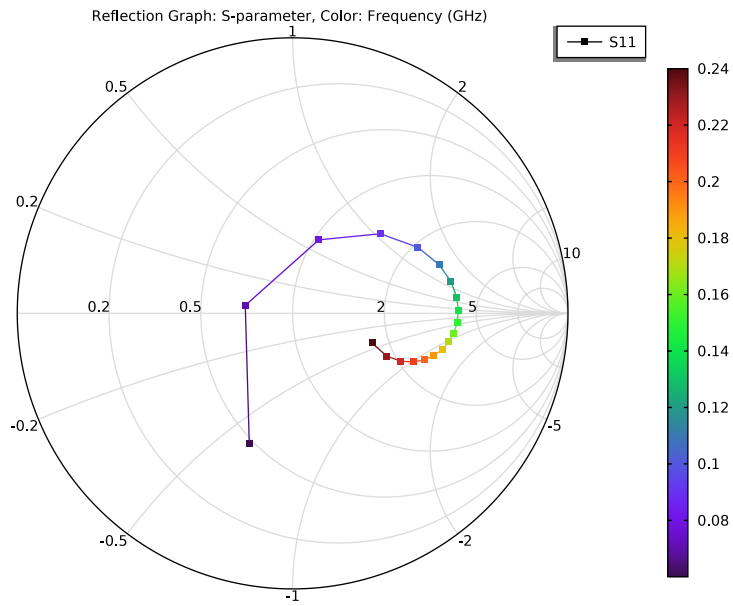

Electric Field, Logarithmic (emw)

In the **Model Builder** window, click **Electric Field, Logarithmic (emw)**.

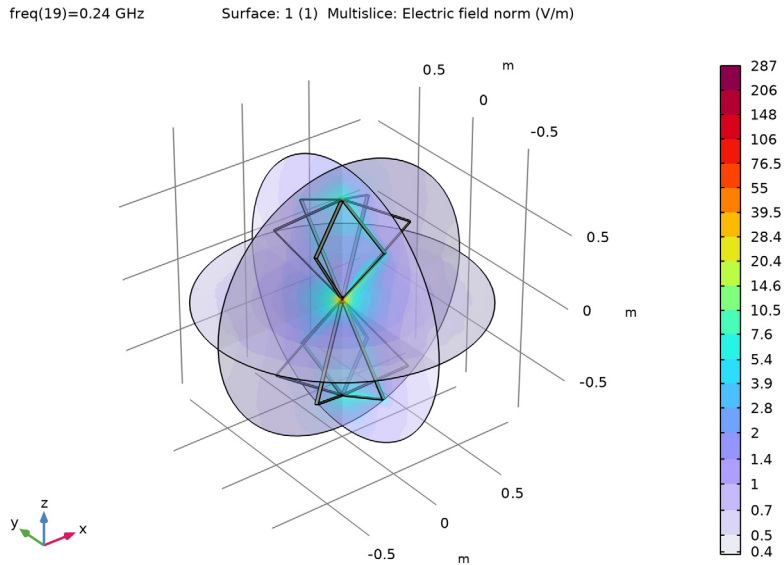

2D Far Field (emw)

- 1 In the **Model Builder** window, click **2D Far Field (emw)**.
- 2 In the **Settings** window for **Polar Plot Group**, locate the **Axis** section.
- 3 Select the **Manual axis limits** checkbox.
- 4 In the **r minimum** text field, type -20.
- 5 In the **r maximum** text field, type 2.

Radiation Pattern 1

- 1 In the **Model Builder** window, expand the **2D Far Field (emw)** node, then click **Radiation Pattern 1**.
- 2 In the **Settings** window for **Radiation Pattern**, click **Replace Expression** in the upper-right corner of the **Expression** section. From the menu, choose **Component 1 (comp1) > Electromagnetic Waves, Frequency Domain > Far field > emw.gaindBefar - Far-field gain, dBi - dB**.
- 3 In the **2D Far Field (emw)** toolbar, click  **Plot**.

Figure 3 shows the 2D far-field gain polar plot.

3D Far Field, Gain (emw)

- 1 In the **Model Builder** window, under **Results** click **3D Far Field, Gain (emw)**.
- 2 In the **Settings** window for **3D Plot Group**, locate the **Data** section.
- 3 From the **Parameter value (freq (GHz))** list, choose **0.07**.
- 4 In the **3D Far Field, Gain (emw)** toolbar, click  **Plot**.

Figure 4 shows the 3D far-field radiation pattern.

VSWR

- 1 In the **Results** toolbar, click  **ID Plot Group**.
- 2 In the **Settings** window for **ID Plot Group**, type VSWR in the **Label** text field.

Global I

- 1 Right-click **VSWR** and choose **Global**.
- 2 In the **Settings** window for **Global**, click **Add Expression** in the upper-right corner of the **y-axis Data** section. From the menu, choose **Component I (comp I) > Electromagnetic Waves, Frequency Domain > Ports > emw.VSWR_I - Voltage standing wave ratio - I**.
- 3 Click to expand the **Coloring and Style** section. Find the **Line markers** subsection. From the **Marker** list, choose **Point**.

VSWR

- 1 In the **Model Builder** window, click **VSWR**.
- 2 In the **Settings** window for **ID Plot Group**, locate the **Axis** section.
- 3 Select the **y-axis log scale** checkbox.
- 4 Select the **Manual axis limits** checkbox.
- 5 In the **y minimum** text field, type 1.
- 6 In the **y maximum** text field, type 100.
- 7 In the **VSWR** toolbar, click  **Plot**.

Compare the VSWR plot with Figure 5.

3D Plot Group 9



In the **Results** toolbar, click  **3D Plot Group**.

Isosurface I

- 1 Right-click **3D Plot Group 9** and choose **Isosurface**.
- 2 In the **Settings** window for **Isosurface**, locate the **Expression** section.
- 3 In the **Expression** text field, type $20 * \log_{10}(\text{emw.normE} + 0.1)$.

- 4 Locate the **Levels** section. In the **Total levels** text field, type 20.
- 5 Locate the **Coloring and Style** section. From the **Color table transformation** list, choose **Nonlinear**.
- 6 Set the **Color calibration parameter** value to **-1.5**.

Filter 1

- 1 Right-click **Isosurface 1** and choose **Filter**.
- 2 In the **Settings** window for **Filter**, locate the **Element Selection** section.
- 3 In the **Logical expression for inclusion** text field, type $x > 0$.
- 4 Click the  **Go to Default View** button in the **Graphics** toolbar.
- 5 Click the  **Zoom In** button in the **Graphics** toolbar.

Selection 1

- 1 In the **Model Builder** window, right-click **Isosurface 1** and choose **Selection**.
- 2 Select Domain 5 only.
- 3 In the **3D Plot Group 9** toolbar, click  **Plot**.

