



Model created in COMSOL Multiphysics 6.4

Antenna Decoupling Using an Electromagnetic Band Gap Metamaterial

Introduction

An *electromagnetic band gap* (EBG) structure can be used to increase the isolation between antennas that are close to each other. This decoupling effect is not only a function of frequency but also of polarization and coupling-plane configuration. In this example, an EBG structure is placed between two antennas. The solution shows a marked decrease in coupling between the two antennas.

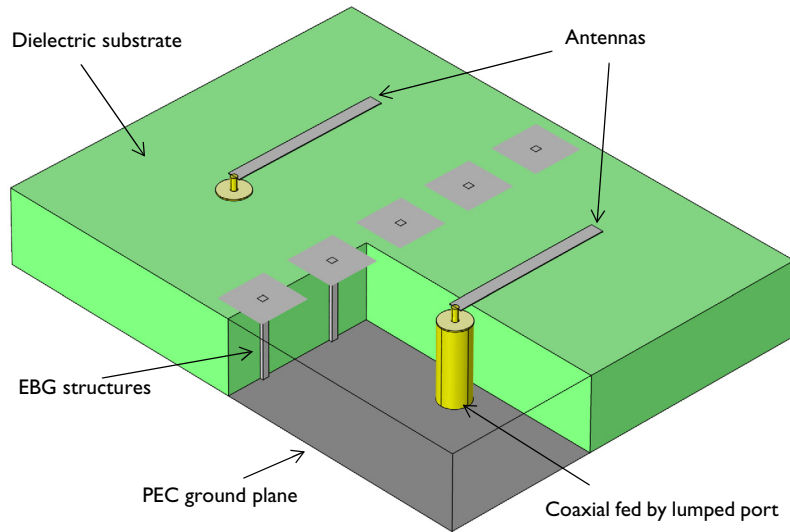

Figure 1: Two 90° bent monopole antennas over a thick substrate separated by electromagnetic band gap structures.

Model Definition

An electromagnetic band gap structure can strongly inhibit the propagation of an electromagnetic wave. Although there are many different structures that can exhibit a band gap, such structures are almost always initially designed at the unit cell level. That is, a single element of the EBG structure is assumed to be patterned infinitely through space, and a separate analysis is performed to find the band gaps.

Once the EBG structure has been engineered to achieve the desired band gap, for an infinite structure, it can be used in a finite-sized space. However, the properties of the structure change slightly because the assumption of infinite periodicity used to compute

the band gaps does not hold any longer. Therefore, it is necessary to compute the performance of an EBG structure in real space.

This example starts with an EBG structure composed of metallic mushrooms that has already been engineered to have a band gap centered at 1.85 GHz. One row of these mushroom structures are placed between two antennas, as shown in [Figure 1](#). A typical use of such an EBG structure is to provide isolation between the elements of an array antenna. This example uses only two antenna elements to demonstrate the concept.

The antenna elements are metal strips, fed by a coaxial cable, sitting above a dielectric substrate on top of the ground plane. Although these are not typical antenna elements, they are used because they highlight the effectiveness of the isolation provided by the mushroom structures. In this analysis only one antenna element is excited, while the other acts as a receiver to determine the coupling.

The antenna array structure is modeled inside an air sphere truncated by a Perfectly Matched Layer, which allows the antenna to radiate freely in all directions. The antenna characteristics are not of primary interest here, however.

The model can be run both with and without the EBG mushroom structures, of which only the former case is considered here. The model is simulated over a range of frequencies around the band gap to observe the change in S_{21} .

Results and Discussion

[Figure 2](#) plots S_{21} for the case of the antenna array with and without the EBG structure, showing a marked improvement when adding the EBG. Because the model only uses a single row of five mushroom elements, the maximum isolation is not exactly at the frequency predicted by the band-gap analysis.

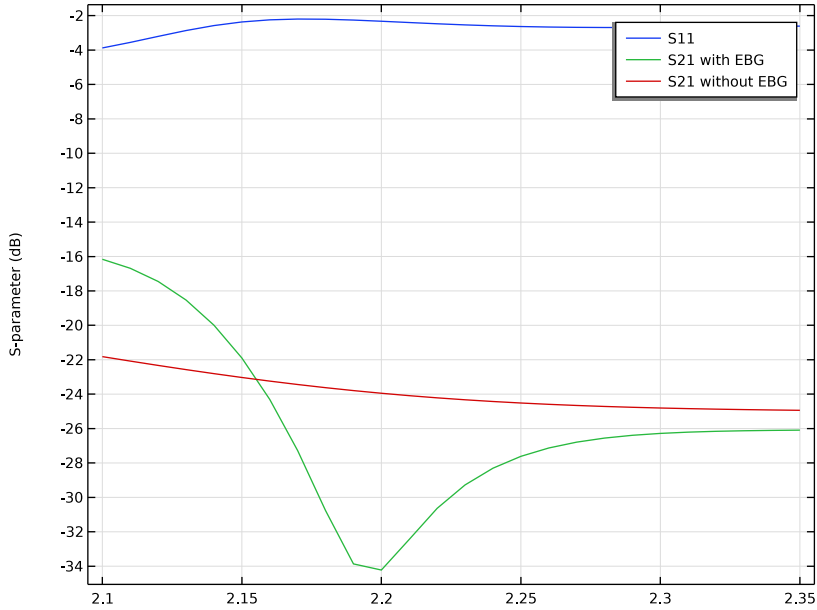

Figure 2: The frequency response of the coupling between two antennas with/without EBG structures shows the decoupling effect around 2.2 GHz.

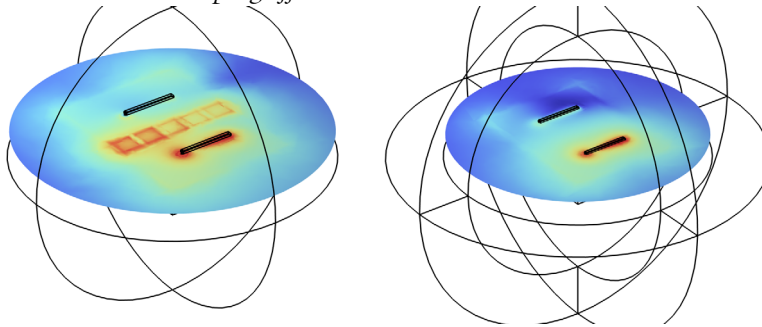

Figure 3: Electric field with EBG (left) and without EBG structures (right).

Two coaxial lumped ports are applied and S_{21} is observed with/without the five EBG structures. As shown in Figure 2, a part of the frequency band has stronger coupling with the EBG structures and the decoupling bandwidth is not wide. The center frequency of the decoupling band is also a function of the configuration of the coupling plane of the two antennas, and adding the EBG structures does not always guarantee better isolation between antennas.

Reference

1. M.N.M. Tan and others, “Antenna array enhancement using mushroom-like electromagnetic band gap (EBG),” *Proc. 4th European Conf. Antennas and Propagation (EuCAP 2010)*, pp. 1–5, 2010.

Application Library path: RF_Module/EMI_EMG_Applications/antenna_ebg



Modeling Instructions

From the **File** menu, choose **New**.

NEW

In the **New** window, click  **Model Wizard**.

MODEL WIZARD

- 1 In the **Model Wizard** window, click  **3D**.
- 2 In the **Select Physics** tree, select **Radio Frequency > Electromagnetic Waves, Frequency Domain (emw)**.
- 3 Click **Add**.
- 4 Click  **Study**.
- 5 In the **Select Study** tree, select **General Studies > Frequency Domain**.
- 6 Click  **Done**.

STUDY 1

Step 1: Frequency Domain

Define the study frequency ahead of performing any frequency-dependent operation such as building mesh. The physics-controlled mesh uses the highest frequency value in the specified range.

- 1 In the **Model Builder** window, under **Study 1** click **Step 1: Frequency Domain**.
- 2 In the **Settings** window for **Frequency Domain**, locate the **Study Settings** section.
- 3 In the **Frequencies** text field, type range (2.1 [GHz] , 10 [MHz] , 2.35 [GHz]).



You can alternatively set the simulation frequency range by clicking the Range button next to the Frequencies text field.

GEOMETRY I

- 1 In the **Model Builder** window, under **Component 1 (comp1)** click **Geometry I**.
- 2 In the **Settings** window for **Geometry**, locate the **Units** section.
- 3 From the **Length unit** list, choose **mm**.



Create a substrate.

Substrate



- 1 In the **Geometry** toolbar, click  **Block**.
- 2 In the **Settings** window for **Block**, type Substrate in the **Label** text field.
- 3 Locate the **Size and Shape** section. In the **Width** text field, type 60.
- 4 In the **Depth** text field, type 80.
- 5 In the **Height** text field, type 12.
- 6 Locate the **Position** section. In the **x** text field, type -30.
- 7 In the **y** text field, type -40.
- 8 Click  **Build Selected**.
- 9 Click the  **Wireframe Rendering** button in the **Graphics** toolbar.

Create a mushroom.

Work Plane 1 (wp1)

- 1 In the **Geometry** toolbar, click  **Work Plane**.
- 2 In the **Settings** window for **Work Plane**, locate the **Plane Definition** section.
- 3 In the **z-coordinate** text field, type 12.
- 4 Click  **Go to Plane Geometry**.

Work Plane 1 (wp1) > Square 1 (sq1)



- 1 In the **Work Plane** toolbar, click  **Square**.
- 2 In the **Settings** window for **Square**, locate the **Size** section.
- 3 In the **Side length** text field, type 8.
- 4 Locate the **Position** section. From the **Base** list, choose **Center**.
- 5 In the **xw** text field, type -24.
- 6 Click  **Build Selected**.

Mushroom

- 1 In the **Model Builder** window, under **Component 1 (comp1) > Geometry I** click **Work Plane 1 (wp1)**.



2 In the **Settings** window for **Work Plane**, type Mushroom in the **Label** text field.

Mushroom Stem

- 1 In the **Geometry** toolbar, click  **Block**.
- 2 In the **Settings** window for **Block**, type Mushroom Stem in the **Label** text field.
- 3 Locate the **Size and Shape** section. In the **Height** text field, type 12.
- 4 Locate the **Position** section. In the **x** text field, type -24.5.
- 5 In the **y** text field, type -0.5.
- 6 Click  **Build Selected**.

Create an array of mushrooms.

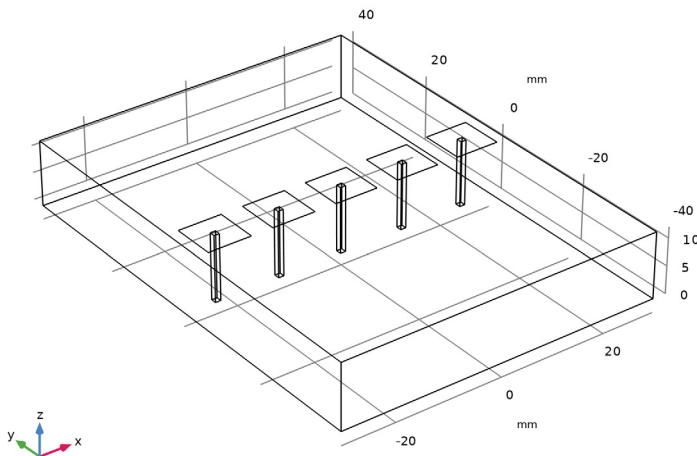

EBG Structure

- 1 In the **Geometry** toolbar, click  **Transforms** and choose **Array**.
- 2 In the **Settings** window for **Array**, type EBG Structure in the **Label** text field.
- 3 Select the objects **blk2** and **wp1** only.
- 4 Locate the **Size** section. In the **x size** text field, type 5.
- 5 Locate the **Displacement** section. In the **x** text field, type 12.
- 6 Click  **Build All Objects**.





Create a coax inner conductor.

Cylinder 1 (cyl1)

- 1 In the **Geometry** toolbar, click  **Cylinder**.
- 2 In the **Settings** window for **Cylinder**, locate the **Size and Shape** section.
- 3 In the **Radius** text field, type 0.5.
- 4 In the **Height** text field, type 14.
- 5 Locate the **Position** section. In the **x** text field, type -10.
- 6 In the **y** text field, type -20.
- 7 Click  **Build Selected**.



Create a coax outer conductor.

Cylinder 2 (cyl2)

- 1 In the **Geometry** toolbar, click  **Cylinder**.
- 2 In the **Settings** window for **Cylinder**, locate the **Size and Shape** section.
- 3 In the **Radius** text field, type 2.35.
- 4 In the **Height** text field, type 12.
- 5 Locate the **Position** section. In the **x** text field, type -10.
- 6 In the **y** text field, type -20.
- 7 Click  **Build Selected**.

Create an antenna radiator.

Block 3 (blk3)

- 1 In the **Geometry** toolbar, click  **Block**.
- 2 In the **Settings** window for **Block**, locate the **Size and Shape** section.
- 3 In the **Width** text field, type 25.
- 4 In the **Depth** text field, type 2.
- 5 Locate the **Position** section. In the **x** text field, type -10.
- 6 In the **y** text field, type -21.
- 7 In the **z** text field, type 13.
- 8 Click  **Build Selected**.

Create a pair of 90-degree bent monopole antennas.

Copy 1 (copy1)

- 1 In the **Geometry** toolbar, click  **Transforms** and choose **Copy**.
- 2 Select the objects **blk3**, **cyl1**, and **cyl2** only.



- 3 In the **Settings** window for **Copy**, locate the **Displacement** section.
- 4 In the **y** text field, type 40.
- 5 Click  **Build Selected**.

Create a sphere for PML layers and an air domain.

Sphere 1 (sph1)

- 1 In the **Geometry** toolbar, click  **Sphere**.
- 2 In the **Settings** window for **Sphere**, locate the **Size** section.
- 3 In the **Radius** text field, type 100.
- 4 Click to expand the **Layers** section. In the table, enter the following settings:

Layer name	Thickness (mm)
Layer 1	30

- 5 Click  **Build All Objects**.
- 6 Click the  **Zoom Extents** button in the **Graphics** toolbar.
- 7 In the **Model Builder** window, click **Geometry 1**.

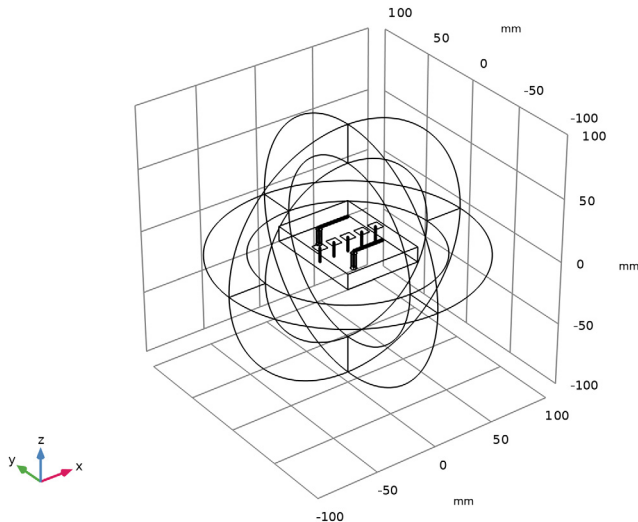

DEFINITIONS

Internal PEC Boundaries

- 1 In the **Definitions** toolbar, click  **Explicit**.

- 2 In the **Settings** window for **Explicit**, type Internal PEC Boundaries in the **Label** text field.
- 3 Locate the **Input Entities** section. From the **Geometric entity level** list, choose **Boundary**.
- 4 Select Boundaries 15, 18, 25, 31, 32, 35, 36, 54, 58, 70, 71, 75, 87, 88, 111, and 120 only.

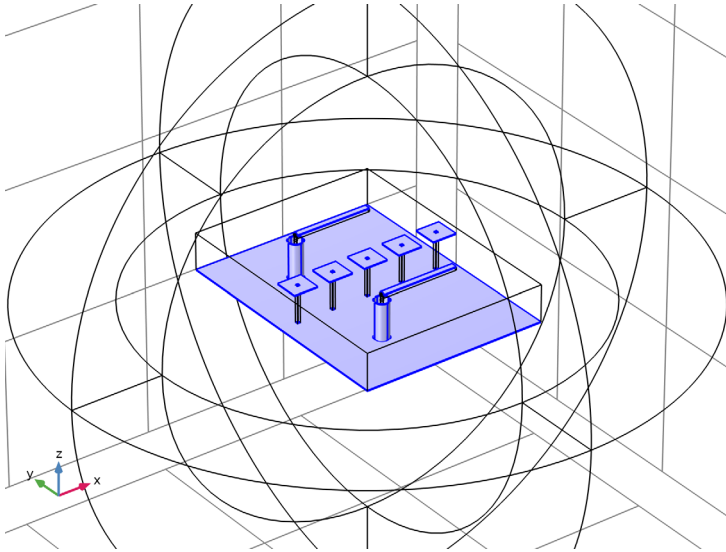

Perfectly Matched Layer 1 (pml1)

- 1 In the **Definitions** toolbar, click  **Perfectly Matched Layer**.
- 2 Select Domains 1–4 and 20–23 only.
- 3 In the **Settings** window for **Perfectly Matched Layer**, locate the **Geometry** section.
- 4 From the **Type** list, choose **Spherical**.

Hide some domains to get a better view of the interior parts.

Hide for Physics 1

- 1 In the **Model Builder** window, right-click **View 1** and choose **Hide for Physics**.
- 2 Select Domains 2 and 5 only.

ELECTROMAGNETIC WAVES, FREQUENCY DOMAIN (EMW)

Perfect Electric Conductor 2

- 1 In the **Physics** toolbar, click  **Boundaries** and choose **Perfect Electric Conductor**.



- 2 In the **Settings** window for **Perfect Electric Conductor**, locate the **Boundary Selection** section.
- 3 From the **Selection** list, choose **Internal PEC Boundaries**.

Perfect Electric Conductor 3

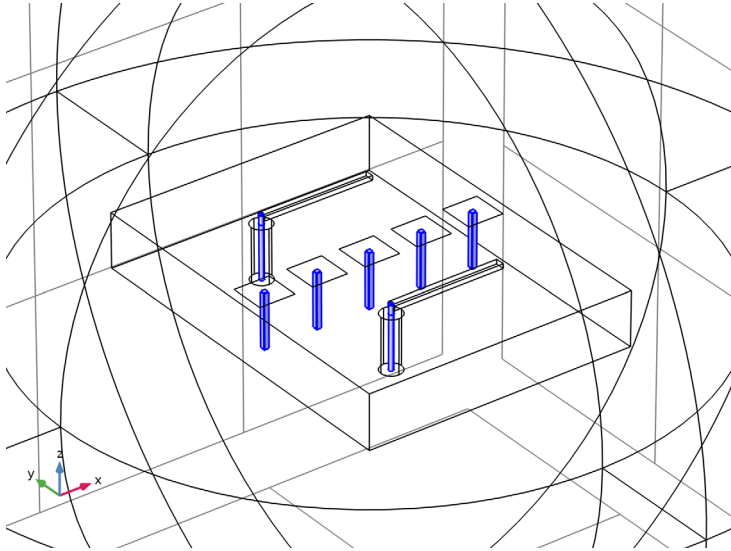
- 1 In the **Physics** toolbar, click  **Domains** and choose **Perfect Electric Conductor**.
- 2 Select Domains 7, 8, 11–14, 16, 18, 19, 24, and 25 only.



Lumped Port 1



- 1 In the **Physics** toolbar, click  **Boundaries** and choose **Lumped Port**.
- 2 Click the  **Zoom In** button in the **Graphics** toolbar, two or three times.
- 3 Select Boundary 33 only.
- 4 In the **Model Builder** window, click **Lumped Port 1**.
- 5 In the **Settings** window for **Lumped Port**, locate the **Lumped Port Properties** section.
- 6 From the **Type of lumped port** list, choose **Coaxial**.
For the first port, wave excitation is **on** by default.

Lumped Port 2

- 1 In the **Physics** toolbar, click  **Boundaries** and choose **Lumped Port**.
- 2 Select Boundary 37 only.
- 3 In the **Settings** window for **Lumped Port**, locate the **Lumped Port Properties** section.

4 From the **Type of lumped port** list, choose **Coaxial**.

ADD MATERIAL

- 1 In the **Materials** toolbar, click  **Add Material** to open the **Add Material** window.
- 2 Go to the **Add Material** window.
- 3 In the tree, select **Built-in > Air**.
- 4 Click the **Add to Component** button in the window toolbar.
- 5 In the **Materials** toolbar, click  **Add Material** to close the **Add Material** window.

MATERIALS

Air (mat1)

Override this material for the substrate and coaxial cable domains.

Substrate

- 1 In the **Model Builder** window, right-click **Materials** and choose **Blank Material**.
- 2 In the **Settings** window for **Material**, type **Substrate** in the **Label** text field.
- 3 Select Domain 6 only.
- 4 Locate the **Material Contents** section. In the table, enter the following settings:

Property	Variable	Value	Unit	Property group
Relative permittivity	epsilon_nr_iso ; epsilon_nrii = epsilon_nr_iso, epsilon_nrij = 0	3.38		Basic
Relative permeability	mu_r_iso ; mu_rii = mu_r_iso, mu_rij = 0	1		Basic
Electric conductivity	sigma_iso ; sigma_ii = sigma_iso, sigma_ij = 0	0	S/m	Basic



PTFE

- 1 Right-click **Materials** and choose **Blank Material**.
- 2 In the **Settings** window for **Material**, type **PTFE** in the **Label** text field.
- 3 Select Domains 9 and 10 only.

4 Locate the **Material Contents** section. In the table, enter the following settings:

Property	Variable	Value	Unit	Property group
Relative permittivity	epsilon _{nr_} iso ; epsilon _{nrii} = epsilon _{nr_} iso, epsilon _{nrij} = 0	2.1		Basic
Relative permeability	mu _{r_} iso ; mu _{rii} = mu _{r_} iso, mu _{rij} = 0	1		Basic
Electric conductivity	sigma _{iso} ; sigma _{ii} = sigma _{iso} , sigma _{ij} = 0	0	S/m	Basic

MESH 1

- 1 In the **Model Builder** window, under **Component 1 (comp1)** click **Mesh 1**.
- 2 In the **Settings** window for **Mesh**, locate the **Physics-Controlled Mesh** section.
- 3 From the **Element size** list, choose **Coarse**.
- 4 Click  **Build All**.
- 5 Click the  **Zoom Extents** button in the **Graphics** toolbar.

6 Click the  **Zoom In** button in the **Graphics** toolbar.

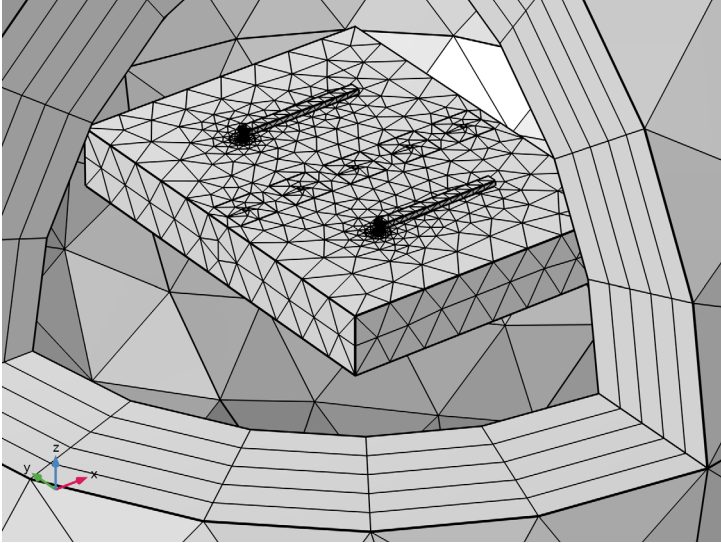

7 Click the  **Reset Hiding** button in the **Graphics** toolbar, to reset the visibility state of the hidden domains in preparation of the results processing.

STUDY 1

In the **Study** toolbar, click  **Compute**.



RESULTS

Electric Field (emw)

- 1 In the **Settings** window for **3D Plot Group**, locate the **Data** section.
- 2 From the **Parameter value (freq (GHz))** list, choose **2.2**.
- 3 Click to expand the **Title** section. From the **Title type** list, choose **None**.

Multislice 1

- 1 In the **Model Builder** window, expand the **Electric Field (emw)** node, then click **Multislice 1**.
- 2 In the **Settings** window for **Multislice**, locate the **Multipane Data** section.
- 3 Find the **X-planes** subsection. In the **Planes** text field, type 0.
- 4 Find the **Y-planes** subsection. In the **Planes** text field, type 0.
- 5 Find the **Z-planes** subsection. From the **Entry method** list, choose **Coordinates**.
- 6 In the **Coordinates** text field, type 12.5.

- 7 Locate the **Expression** section. In the **Expression** text field, type $20 \cdot \log_{10}(emw.normE)$.
- 8 Locate the **Coloring and Style** section. Clear the **Color legend** checkbox.
- 9 In the **Electric Field (emw)** toolbar, click  **Plot**.
- 10 Click the  **Zoom Extents** button in the **Graphics** toolbar.
- 11 Click the  **Zoom In** button in the **Graphics** toolbar.

The following instructions reproduce the frequency-response plot shown in [Figure 2](#):

Global 1

- 1 In the **Model Builder** window, expand the **Results > S-Parameter (emw)** node, then click **Global 1**.
- 2 In the **Settings** window for **Global**, click to expand the **Legends** section.
- 3 From the **Legends** list, choose **Manual**.
- 4 In the table, enter the following settings:

Legends
S11
S21 with EBG

S-Parameter (emw)

- 1 In the **Model Builder** window, click **S-Parameter (emw)**.
- 2 In the **Settings** window for **ID Plot Group**, click to expand the **Title** section.
- 3 From the **Title type** list, choose **None**.
- 4 In the **S-Parameter (emw)** toolbar, click  **Plot**.

To re-solve the model without EBG mushroom structures, do as follows:

Under **Model 1 > Geometry 1** select Mushroom, Mushroom Stem, and EBG Structure, choose Disable.

Right-click **Study 1** and choose **Compute**.

The computation takes about 10 minutes. Here, the table with computed S_{21} parameter values is imported for convenience.

Table 2

In the **Results** toolbar, click  **Table**.

Probe Table 1

- 1 In the **Model Builder** window, click **Probe Table 1**.



- 2 In the **Settings** window for **Table**, locate the **Data** section.
- 3 Click  **Import**.
- 4 Browse to the model's Application Libraries folder and double-click the file `antenna_ebg_without_S21_parameter.txt`.

Table Graph 1

- 1 In the **Model Builder** window, right-click **S-Parameter (emw)** and choose **Table Graph**.
- 2 In the **Settings** window for **Table Graph**, click to expand the **Legends** section.
- 3 Select the **Show legends** checkbox.
- 4 From the **Legends** list, choose **Manual**.
- 5 In the table, enter the following settings:

Legends
S21 without EBG

- 6 In the **S-Parameter (emw)** toolbar, click  **Plot**.

Smith Plot (emw)

In the **Model Builder** window, under **Results** click **Smith Plot (emw)**.

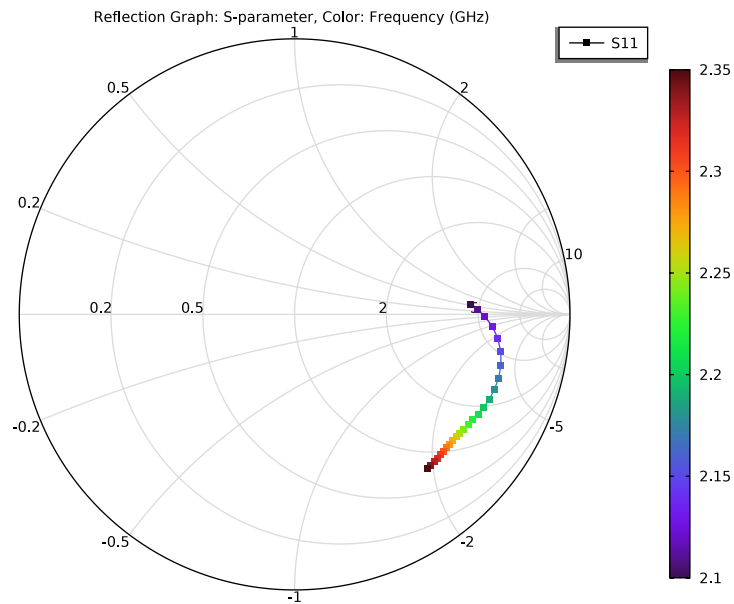

Electric Field, Logarithmic (emw)

In the **Model Builder** window, click **Electric Field, Logarithmic (emw)**.

freq(26)=2.35 GHz Surface: 1 (1) Surface: 1 (1) Surface: Electric field norm (V/m)

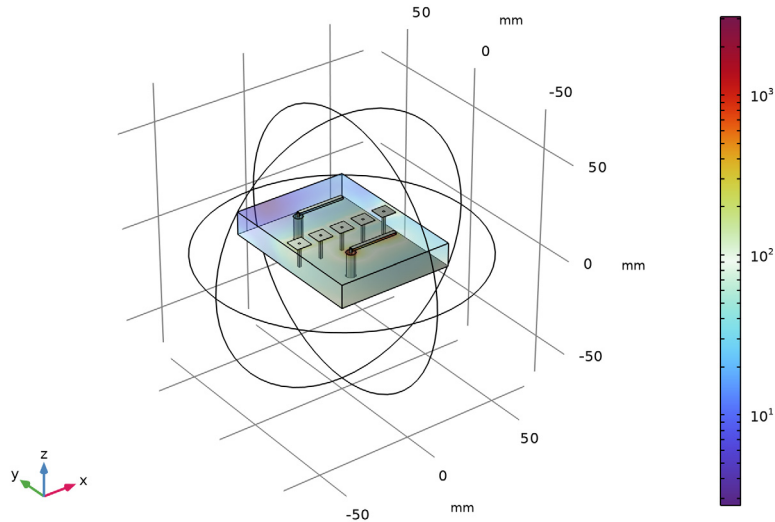

Analyze the same model with a much finer frequency resolution using **Adaptive Frequency Sweep** based on asymptotic waveform evaluation (AWE). When a device presents a slowly varying frequency response, the AWE method provides a faster solution time when running the simulation on many frequency points. The following example with the Adaptive Frequency Sweep can be computed five times faster than regular Frequency Domain sweeps with a same finer frequency resolution.

ELECTROMAGNETIC WAVES, FREQUENCY DOMAIN (EMW)



Lumped Port 1

- 1 In the **Model Builder** window, under **Component 1 (comp1) > Electromagnetic Waves, Frequency Domain (emw)** click **Lumped Port 1**.
- 2 In the **Settings** window for **Lumped Port**, locate the **Boundary Selection** section.
- 3 Click  **Create Selection**.
- 4 In the **Create Selection** dialog, type Lumped port 1 in the **Selection name** text field.
- 5 Click **OK**.

Lumped Port 2

- 1 In the **Model Builder** window, click **Lumped Port 2**.
- 2 In the **Settings** window for **Lumped Port**, locate the **Boundary Selection** section.
- 3 Click  **Create Selection**.
- 4 In the **Create Selection** dialog, type Lumped port 2 in the **Selection name** text field.
- 5 Click **OK**.

ADD STUDY

- 1 In the **Home** toolbar, click  **Add Study** to open the **Add Study** window.
- 2 Go to the **Add Study** window.
- 3 Find the **Studies** subsection. In the **Select Study** tree, select **Preset Studies for Selected Physics Interfaces > Adaptive Frequency Sweep**.
- 4 Click the **Add Study** button in the window toolbar.
- 5 In the **Home** toolbar, click  **Add Study** to close the **Add Study** window.

STUDY 2

Step 1: Adaptive Frequency Sweep

- 1 In the **Settings** window for **Adaptive Frequency Sweep**, locate the **Study Settings** section.
- 2 In the **Frequencies** text field, type range (2.1 [GHz], 2 [MHz], 2.35 [GHz]).
Use a five times finer frequency resolution.
- 3 From the **AWE expression type** list, choose **User controlled**.
- 4 In the table, enter the following settings:

Asymptotic waveform evaluation (AWE) expressions

abs (comp1.emw.S11)

A slowly varying scalar value curve works well for AWE expression. Use `abs (comp1.emw.S11)` for this model.

Because such a fine frequency step generates a memory-intensive solution, the model file size will increase tremendously when it is saved. When only the frequency response of port related variables are of interest, it is not necessary to store all of the field solutions. By selecting the **Store in Output** checkbox in the **Values of Dependent Variables** section, we can control the part of the model on which the computed solution is saved. We only add the selection containing these boundaries where the port variables are calculated. The lumped port size is typically very small compared to the entire modeling domain, and the saved file size with the fine frequency step is more or less that of the

regular discrete frequency sweep model when only the solutions on the port boundaries are stored.

5 Click to expand the **Store in Output** section. In the table, enter the following settings:

Interface	Output
Electromagnetic Waves, Frequency Domain (emw)	Selection

6 Click to select the first row in the table.

7 Under **Selections**, click  **Add**.

8 In the **Add** dialog, in the **Selections** list, choose **Lumped port 1** and **Lumped port 2**.

9 Click **OK**.

It is necessary to include the lumped port boundaries to calculate S-parameters. By choosing only the lumped port boundaries for **Store in Output** settings, it is possible to reduce the size of a model file a lot.

10 In the **Study** toolbar, click  **Compute**.

RESULTS

Multislice 1

1 In the **Model Builder** window, expand the **Electric Field (emw) 1** node.

2 Right-click **Multislice 1** and choose **Delete**.

Surface 1

Right-click **Electric Field (emw) 1** and choose **Surface**.

Selection 1

1 In the **Model Builder** window, right-click **Surface 1** and choose **Selection**.

2 Select Boundaries 33 and 37 only.

3 In the **Electric Field (emw) 1** toolbar, click  **Plot**.

S-Parameter (emw) 1

1 In the **Model Builder** window, under **Results** click **S-Parameter (emw) 1**.

2 In the **Settings** window for **ID Plot Group**, locate the **Legend** section.

3 From the **Position** list, choose **Middle right**.

Global 1

1 In the **Model Builder** window, expand the **S-Parameter (emw) 1** node, then click **Global 1**.

2 In the **Settings** window for **Global**, locate the **y-Axis Data** section.

3 In the table, enter the following settings:

Expression	Unit	Description
emw.S11dB	dB	S11 Adaptive Frequency Sweep
emw.S21dB	dB	S21 Adaptive Frequency Sweep

Global 2

1 Right-click **Results > S-Parameter (emw) I > Global I** and choose **Duplicate**.

2 In the **Settings** window for **Global**, locate the **y-Axis Data** section.

3 In the table, enter the following settings:

Expression	Unit	Description
emw.S11dB	dB	S11 Regular Sweep
emw.S21dB	dB	S21 Regular Sweep

4 Locate the **Data** section. From the **Dataset** list, choose **Study 1/Solution 1 (sol1)**.

5 Click to expand the **Coloring and Style** section. Find the **Line style** subsection. From the **Line** list, choose **Dotted**.

6 Find the **Line markers** subsection. From the **Marker** list, choose **Cycle**.

7 In the **S-Parameter (emw) I** toolbar, click  **Plot**.

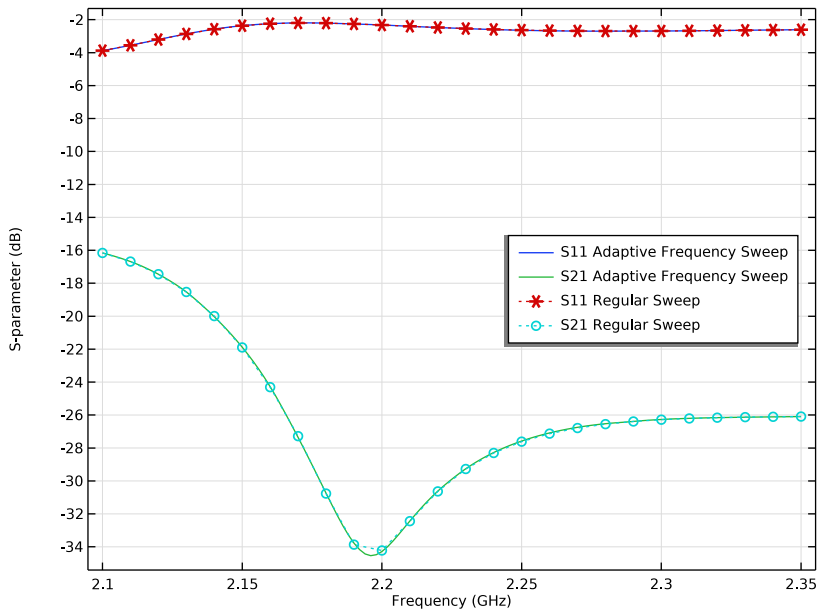

Smith Plot (emw) 1

In the **Model Builder** window, under **Results** click **Smith Plot (emw) 1**.

