



Model created in COMSOL Multiphysics 6.4

Anechoic Chamber Absorbing Electromagnetic Waves

Introduction

An anechoic chamber is a measurement facility for antenna characterization, electromagnetic interference (EMI), and electromagnetic compatibility (EMC) tests. By absorbing electromagnetic waves inside the chamber and blocking the incoming signals from the outside, it creates a virtually infinite space that has almost zero internal reflection and does not suffer from unwanted external RF noises, so the device-under-test in the chamber can be accurately measured without any interference. This model simulates a biconical antenna, popularly used in EMI and EMC tests, which is located at the center of a small anechoic chamber. The computed far-field radiation pattern and S-parameter (S11) demonstrate that the microwave absorbers reduce reflection from the walls significantly without distorting antenna performance.

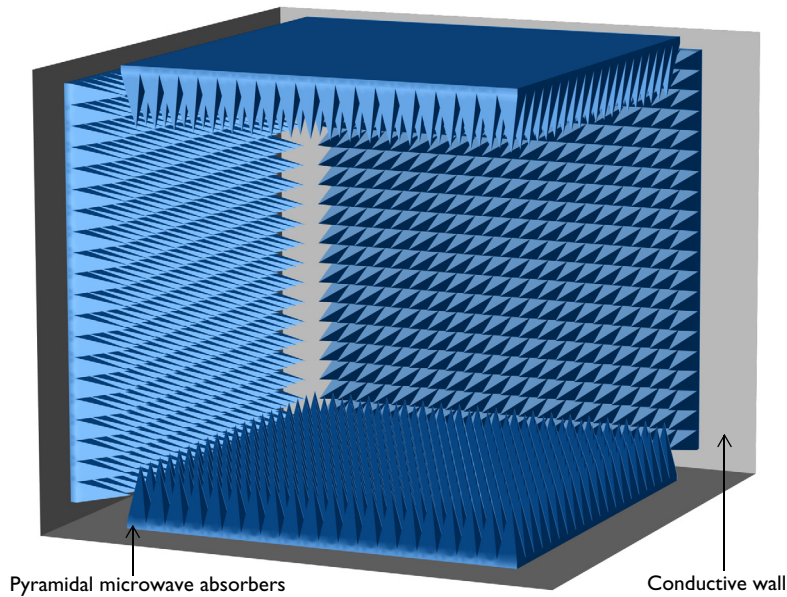

Figure 1: A state-of-the-art anechoic chamber built in a small room ($3.9m \times 3.9m \times 3.3m$). It consists of microwave absorbers on thin conductive walls. Two side walls are not included in this figure.

Model Definition

The shape of the absorbers is configured with the array of pyramidal objects to steer the propagation direction of the incident field on the absorbers reflected back not to the radiation source, but toward the surface of the adjacent absorbers. The radiation-absorbent material (RAM), conductive carbon-loaded foam in the pyramidal shaped

absorber, is modeled using a low conductive material ($\sigma = 0.5 \text{ S/m}$). So the electromagnetic waves illuminated on the absorber has the process of partial reflection and partial transmission with subsequent attenuation that is repeated until the wave reaches the base of the pyramid. The amplitude of the field at the base of the pyramid is drastically reduced. Thus, the reflection from the absorbers at this point is marginal.

The exterior of the chamber is finished with a perfect electric conductor (PEC) to model metallic surfaces that insulate the chamber from the outside RF noises.

The imported biconical antenna geometry is identical to the one used in another application library example, Modeling a Biconical Antenna for EMI/EMC Testing (Ref. 1). This reference model is simulating the same antenna geometry but the antenna is enclosed by a numerical version of an anechoic chamber that is a perfectly matched layer (PML).

The metallic surfaces of the antenna are also configured by PEC. A lumped port with a 50Ω reference impedance is assigned to the gap located at the center of the two structures composed of hexagonal frames. All domains except for the absorbers is filled with the air.

The simulation frequency is set to 240 MHz.

Results and Discussion

The far-field polar plot as a function of azimuth angle is visualized in Figure 2. The plotting plane is perpendicular to the dominant polarization of the antenna so it is the H-plane radiation pattern. Just like the radiation pattern of the biconical antenna surrounded by the PML in Ref. 1, it is isotropic since the reflection from the chamber walls, that are made of the lossy conductive pyramidal form array, is negligible. The computed S-parameter (S_{11}) is around -10 dB that is very close to the value evaluated at 240 MHz in Ref. 1, which also indicates that the reflection from the chamber walls is marginal.

Figure 3 shows one way to enhance the quality of the results postprocessing by utilizing solution set selections and uniform custom colors. The contour of the norm of electric fields in a dB-scale is plotted in a realistic view of an anechoic chamber. The exterior metallic walls are visualized with the norm of electric fields using the GrayScale color table.

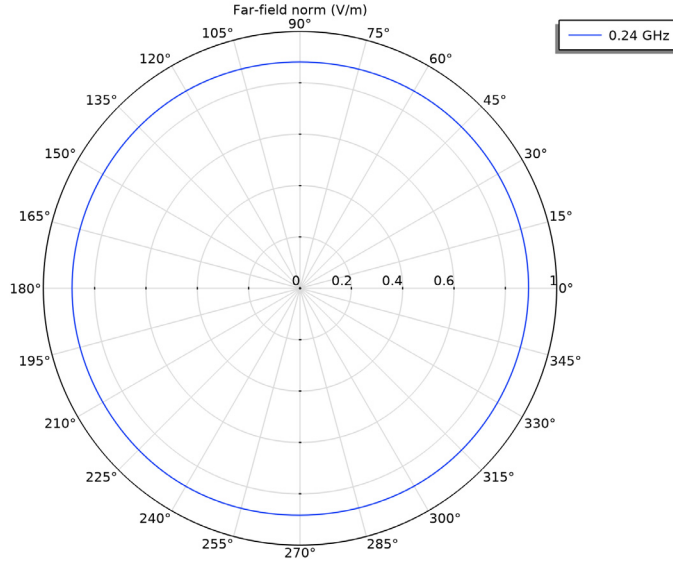

Figure 2: The far-field radiation pattern on the H-plane of the biconical antenna at 240 MHz. It is isotropic as expected.

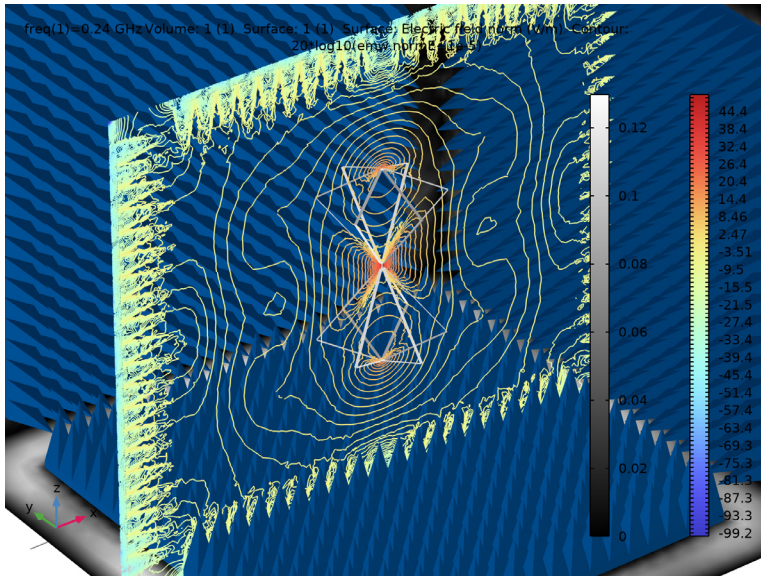

Figure 3: The contour plot of the norm of the electric field (dB-scaled). The strength of the field is gradually decaying inside absorbers.

References

1. *Modeling a Biconical Antenna for EMI/EMC Testing*, COMSOL Application Libraries.

Notes About the COMSOL Implementation

The example model is memory intensive and may require more than 20 GB RAM. The goal of this model is not to simulate an antenna but to design a state-of-the-art anechoic chamber and validate it based on the performance of the antenna. It is recommended to use a PML instead of absorber models to simulate antennas efficiently. The same biconical antenna with the PML (Ref. 1) may need less than 3 GB memory. Note that the anechoic model is not designed in full compliance with well-known standards such as CISPR and ANSI.

Application Library path: RF_Module/EMI_EMG_Applications/anechoic_chamber



Model Instructions

From the **File** menu, choose **New**.

NEW

In the **New** window, click  **Model Wizard**.

MODEL WIZARD

- 1 In the **Model Wizard** window, click  **3D**.
- 2 In the **Select Physics** tree, select **Radio Frequency > Electromagnetic Waves, Frequency Domain (emw)**.
- 3 Click **Add**.
- 4 Click  **Study**.
- 5 In the **Select Study** tree, select **General Studies > Frequency Domain**.
- 6 Click  **Done**.

STUDY 1



Step 1: Frequency Domain

Define the study frequency ahead of performing any frequency-dependent operation such as building mesh. The physics-controlled mesh uses the specified frequency value.

- 1 In the **Model Builder** window, under **Study 1** click **Step 1: Frequency Domain**.
- 2 In the **Settings** window for **Frequency Domain**, locate the **Study Settings** section.
- 3 In the **Frequencies** text field, type 240[MHZ].

GEOMETRY 1

Block 1 (blk1)

- 1 In the **Geometry** toolbar, click  **Block**.
- 2 In the **Settings** window for **Block**, locate the **Size and Shape** section.
- 3 In the **Width** text field, type 3.9.
- 4 In the **Depth** text field, type 3.9.
- 5 In the **Height** text field, type 3.3.
- 6 Locate the **Position** section. From the **Base** list, choose **Center**.
- 7 Click  **Build Selected**.
- 8 Click the  **Wireframe Rendering** button in the **Graphics** toolbar.

Pyramid 1 (pyr1)

- 1 In the **Geometry** toolbar, click  **More Primitives** and choose **Pyramid**.
- 2 In the **Settings** window for **Pyramid**, locate the **Size and Shape** section.
- 3 In the **Base length 1** text field, type 0.15.
- 4 In the **Base length 2** text field, type 0.15.
- 5 In the **Height** text field, type 0.4.
- 6 In the **Ratio** text field, type 0.
- 7 Locate the **Position** section. In the **x** text field, type -1.425.
- 8 In the **y** text field, type -1.425.
- 9 In the **z** text field, type -1.6.

Block 2 (blk2)

- 1 In the **Geometry** toolbar, click  **Block**.
- 2 In the **Settings** window for **Block**, locate the **Size and Shape** section.

- 3 In the **Width** text field, type 0.15.
- 4 In the **Depth** text field, type 0.15.
- 5 In the **Height** text field, type 0.05.
- 6 Locate the **Position** section. In the **x** text field, type -1.5.
- 7 In the **y** text field, type -1.5.
- 8 In the **z** text field, type -1.65.

Union 1 (uni1)

- 1 In the **Geometry** toolbar, click  **Booleans and Partitions** and choose **Union**.
- 2 Select the objects **blk2** and **pyr1** only.

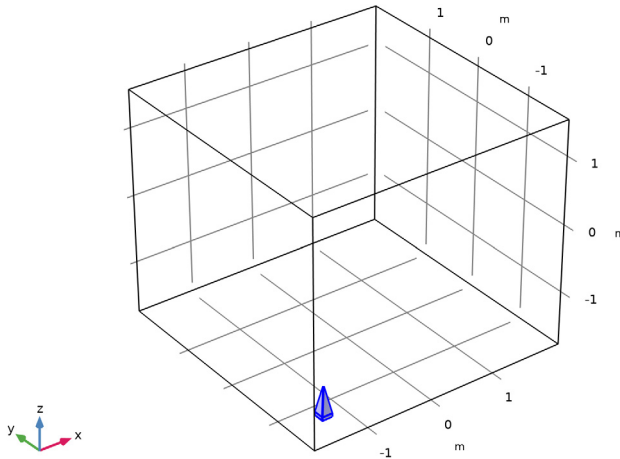

- 3 In the **Settings** window for **Union**, locate the **Union** section.
- 4 Clear the **Keep interior boundaries** checkbox.

Array 1 (arr1)

- 1 In the **Geometry** toolbar, click  **Transforms** and choose **Array**.
- 2 Select the object **uni1** only.
- 3 In the **Settings** window for **Array**, locate the **Size** section.
- 4 In the **x size** text field, type 20.
- 5 In the **y size** text field, type 20.
- 6 Locate the **Displacement** section. In the **x** text field, type 0.15.

7 In the **y** text field, type 0.15.

Union 2 (uni2)

- 1 In the **Geometry** toolbar, click  **Booleans and Partitions** and choose **Union**.
Select all objects in the array as shown in the figure below.

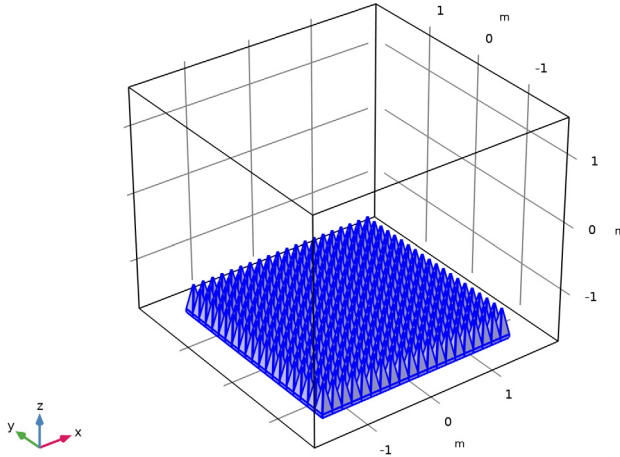

- 2 In the **Settings** window for **Union**, locate the **Union** section.
- 3 Clear the **Keep interior boundaries** checkbox.

Mirror 1 (mir1)

- 1 In the **Geometry** toolbar, click  **Transforms** and choose **Mirror**.
- 2 Select the object **uni2** only.
- 3 In the **Settings** window for **Mirror**, locate the **Input** section.
- 4 Select the **Keep input objects** checkbox.

Rotate 1 (rot1)

- 1 In the **Geometry** toolbar, click  **Transforms** and choose **Rotate**.
- 2 Select the object **uni2** only.
- 3 In the **Settings** window for **Rotate**, locate the **Input** section.
- 4 Select the **Keep input objects** checkbox.
- 5 Locate the **Rotation** section. In the **Angle** text field, type 90.
- 6 Locate the **Point on Axis of Rotation** section. In the **x** text field, type -0.15.

- 7 In the **z** text field, type 0.15.
- 8 Locate the **Rotation** section. From the **Axis type** list, choose **y-axis**.

Rotate 2 (rot2)

- 1 In the **Geometry** toolbar, click  **Transforms** and choose **Rotate**.
- 2 Select the object **rot1** only.
- 3 In the **Settings** window for **Rotate**, locate the **Rotation** section.
- 4 In the **Angle** text field, type 0 90 180 270.

Union 3 (uni3)

- 1 In the **Geometry** toolbar, click  **Booleans and Partitions** and choose **Union**.
- 2 Select the objects **mir1**, **rot2(1)**, **rot2(2)**, **rot2(3)**, **rot2(4)**, and **uni2** only.
- 3 In the **Settings** window for **Union**, locate the **Selections of Resulting Entities** section.
- 4 Find the **Cumulative selection** subsection. Click **New**.
- 5 In the **New Cumulative Selection** dialog, Create a set of absorber selections that will make easier to set up the physics and material.
- 6 type Absorbers in the **Name** text field.
- 7 Click **OK**.

Sphere 1 (sph1)

- 1 In the **Geometry** toolbar, click  **Sphere**.
- 2 In the **Settings** window for **Sphere**, locate the **Selections of Resulting Entities** section.
- 3 Find the **Cumulative selection** subsection. Click **New**.
- 4 In the **New Cumulative Selection** dialog, Create a set of far-field selections.
- 5 type Far-field in the **Name** text field.
- 6 Click **OK**.

Import 1 (imp1)

- 1 In the **Geometry** toolbar, click  **Import**.
- 2 In the **Settings** window for **Import**, locate the **Source** section.
- 3 In the **Filename** text field, type `anechoic_chamber_antenna.mphbin`.
- 4 Locate the **Selections of Resulting Entities** section. Find the **Cumulative selection** subsection. Click **New**.
- 5 In the **New Cumulative Selection** dialog, Create a set of antenna geometry selections.
- 6 type Antenna in the **Name** text field.

7 Click **OK**.

8 In the **Geometry** toolbar, click  **Build All**.

9 Click the  **Wireframe Rendering** button in the **Graphics** toolbar.

10 Click the  **Transparency** button in the **Graphics** toolbar.

11 In the **Model Builder** window, click **Geometry 1**.

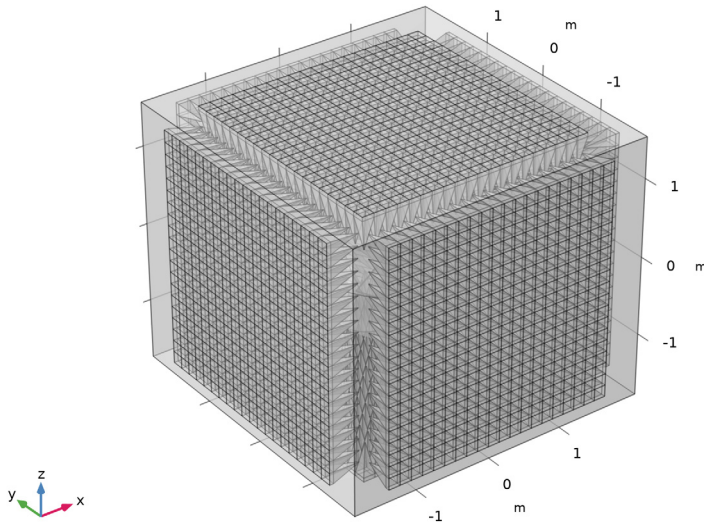

Adjust the graphics window settings as you prefer for the remaining modeling steps.

12 Click the  **Transparency** button in the **Graphics** toolbar.

13 Click the  **Wireframe Rendering** button in the **Graphics** toolbar.

14 Click the  **Zoom In** button in the **Graphics** toolbar.

ADD MATERIAL

1 In the **Materials** toolbar, click  **Add Material** to open the **Add Material** window.

2 Go to the **Add Material** window.

3 In the tree, select **Built-in > Air**.

4 Click the **Add to Component** button in the window toolbar.

5 In the **Materials** toolbar, click  **Add Material** to close the **Add Material** window.

MATERIALS

Absorbers

- 1 In the **Model Builder** window, under **Component 1 (comp1)** right-click **Materials** and choose **Blank Material**.
- 2 In the **Settings** window for **Material**, type Absorbers in the **Label** text field.
- 3 Locate the **Geometric Entity Selection** section. From the **Selection** list, choose **Absorbers**.
- 4 Locate the **Material Contents** section. In the table, enter the following settings:



Property	Variable	Value	Unit	Property group
Relative permittivity	ϵ_{iso} ; $\epsilon_{\text{r}ii} = \epsilon_{\text{iso}}$, $\epsilon_{\text{r}ij} = 0$	1		Basic
Relative permeability	μ_{iso} ; $\mu_{\text{r}ii} = \mu_{\text{iso}}$, $\mu_{\text{r}ij} = 0$	1		Basic
Electric conductivity	σ_{iso} ; $\sigma_{\text{ia}ii} = \sigma_{\text{iso}}$, $\sigma_{\text{ia}ij} = 0$	0.5	S/m	Basic

ELECTROMAGNETIC WAVES, FREQUENCY DOMAIN (EMW)

Perfect Electric Conductor 2

- 1 In the **Physics** toolbar, click  **Boundaries** and choose **Perfect Electric Conductor**.
- 2 In the **Settings** window for **Perfect Electric Conductor**, locate the **Boundary Selection** section.
- 3 From the **Selection** list, choose **Antenna**.

Lumped Port 1

- 1 In the **Physics** toolbar, click  **Boundaries** and choose **Lumped Port**.
Add a lumped port at the center of the antenna. Zoom in a few of times to get a clear view.
- 2 In the **Settings** window for **Lumped Port**, locate the **Boundary Selection** section.
- 3 Click  **Paste Selection**.
- 4 In the **Paste Selection** dialog, type 6310 in the **Selection** text field.

5 Click **OK**.

For the first port, wave excitation is **on** by default.

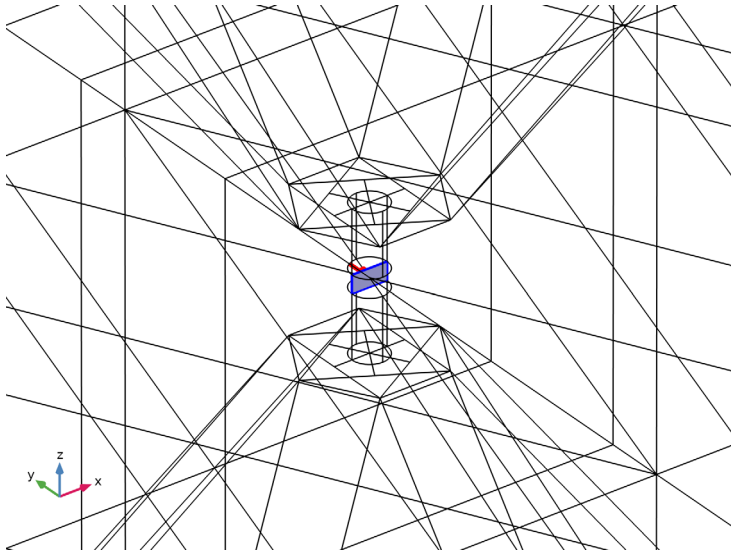

Far-Field Domain 1

- 1 In the **Physics** toolbar, click  **Domains** and choose **Far-Field Domain**.
- 2 In the **Settings** window for **Far-Field Domain**, locate the **Domain Selection** section.
- 3 From the **Selection** list, choose **Far-field**.

Far-Field Calculation 1

- 1 In the **Model Builder** window, expand the **Far-Field Domain 1** node, then click **Far-Field Calculation 1**.
- 2 In the **Settings** window for **Far-Field Calculation**, locate the **Boundary Selection** section.
- 3 Click  **Clear Selection**.
- 4 From the **Selection** list, choose **Far-field**.

STUDY 1

Step 1: Frequency Domain

In the **Study** toolbar, click  **Compute**.

RESULTS

Electric Field (emw)

- 1 In the **Settings** window for **3D Plot Group**, locate the **Plot Settings** section.
- 2 Clear the **Plot dataset edges** checkbox.

Multislice 1

- 1 In the **Model Builder** window, expand the **Electric Field (emw)** node, then click **Multislice 1**.
- 2 In the **Settings** window for **Multislice**, locate the **Expression** section.
- 3 In the **Expression** text field, type $20 * \log_{10}(emw.normE)$.
- 4 Locate the **Multiplane Data** section. Find the **Y-planes** subsection. In the **Planes** text field, type 0.
- 5 Find the **Z-planes** subsection. In the **Planes** text field, type 0.
- 6 Click to expand the **Range** section. Select the **Manual color range** checkbox.
- 7 In the **Minimum** text field, type -40.
- 8 In the **Maximum** text field, type 20.
- 9 In the **Electric Field (emw)** toolbar, click  **Plot**.

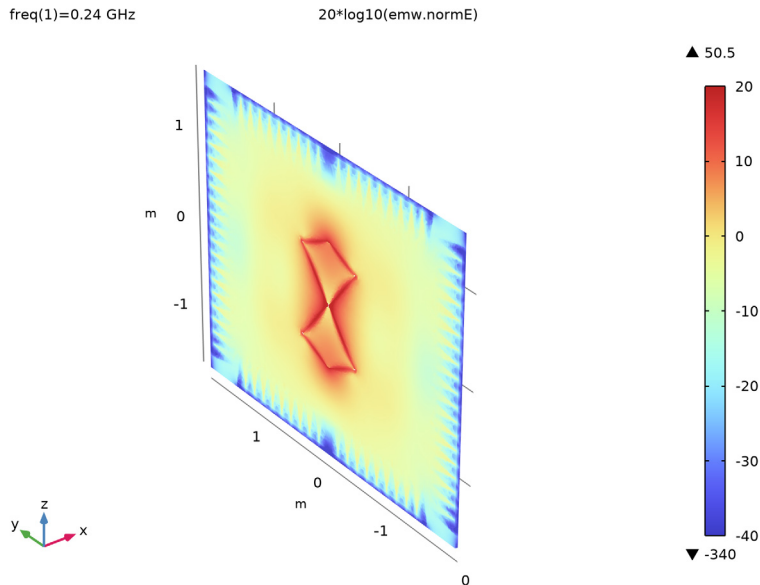

Electric Field, Logarithmic (emw)

In the **Model Builder** window, under **Results** click **Electric Field, Logarithmic (emw)**.

freq(1)=0.24 GHz Surface: 1 (1) Surface: 1 (1) Surface: Electric field norm (V/m) Multislice: Electric field norm (V/m) Surface: Electric field norm (V/m)

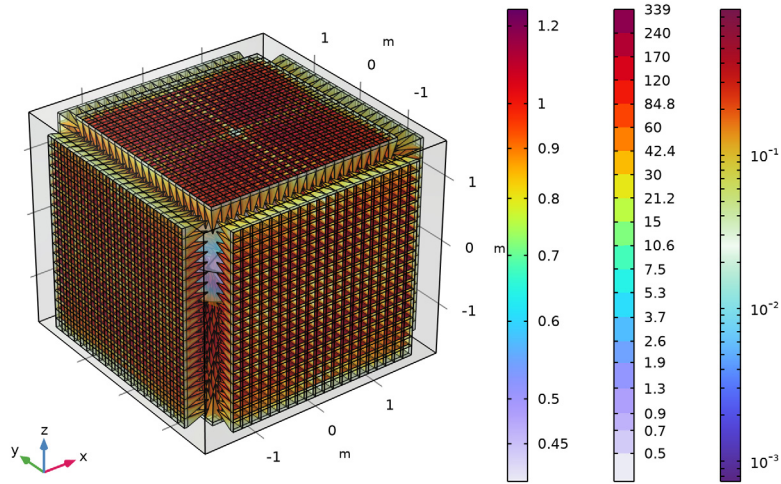

2D Far Field (emw)

- 1 In the **Model Builder** window, click **2D Far Field (emw)**.
- 2 In the **Settings** window for **Polar Plot Group**, locate the **Axis** section.
- 3 Select the **Manual axis limits** checkbox.
- 4 In the **r minimum** text field, type 0.
- 5 In the **r maximum** text field, type 1.
- 6 In the **2D Far Field (emw)** toolbar, click  **Plot**.

Compare the reproduced plot to [Figure 2](#).

3D Far Field, Gain (emw)

In the **Model Builder** window, click **3D Far Field, Gain (emw)**.

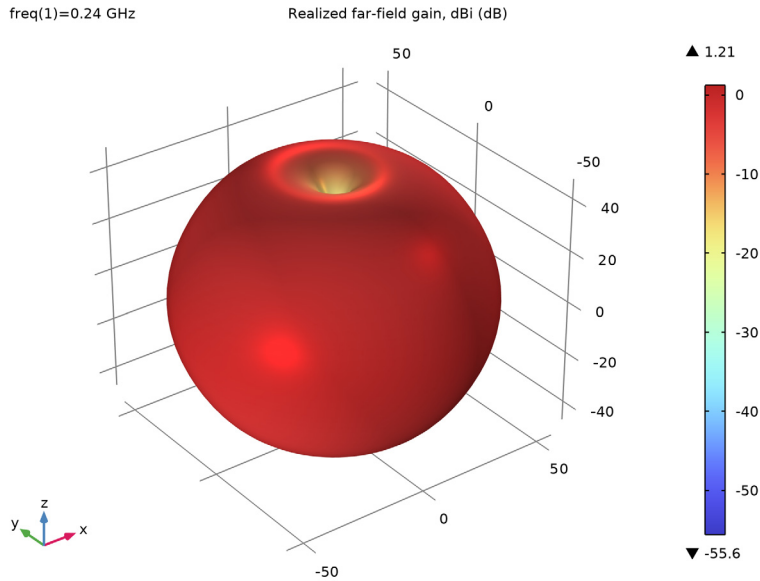

3D Plot Group 6

- 1 In the **Results** toolbar, click  **3D Plot Group**.
- 2 In the **Settings** window for **3D Plot Group**, locate the **Color Legend** section.
- 3 Clear the **Show legends** checkbox.
- 4 Locate the **Plot Settings** section. Clear the **Plot dataset edges** checkbox.

Volume 1

- 1 Right-click **3D Plot Group 6** and choose **Volume**.
- 2 In the **Settings** window for **Volume**, locate the **Expression** section.
- 3 In the **Expression** text field, type 1.
- 4 Locate the **Coloring and Style** section. From the **Coloring** list, choose **Uniform**.
- 5 From the **Color** list, choose **Custom**.
- 6 On Windows, click the colored bar underneath, or — if you are running the cross-platform desktop — the **Color** button.
- 7 Click **Define custom colors**.
- 8 Set the RGB values to 0, 64, and 128, respectively.

9 Click **Add to custom colors**.

10 Click **Show color palette only** or **OK** on the cross-platform desktop.

Selection 1

1 Right-click **Volume 1** and choose **Selection**.

2 In the **Settings** window for **Selection**, locate the **Selection** section.

3 Click  **Paste Selection**.

4 In the **Paste Selection** dialog, type 4, 6, 10 in the **Selection** text field.

5 Click **OK**.

Surface 1

1 In the **Model Builder** window, right-click **3D Plot Group 6** and choose **Surface**.

2 In the **Settings** window for **Surface**, locate the **Expression** section.

3 In the **Expression** text field, type 1.

4 Locate the **Coloring and Style** section. From the **Coloring** list, choose **Uniform**.

5 From the **Color** list, choose **White**.

Selection 1

1 Right-click **Surface 1** and choose **Selection**.

2 In the **Settings** window for **Selection**, locate the **Selection** section.

3 From the **Selection** list, choose **Antenna**.

Surface 2

1 In the **Model Builder** window, right-click **3D Plot Group 6** and choose **Surface**.

2 In the **Settings** window for **Surface**, locate the **Coloring and Style** section.

3 From the **Color table** list, choose **GrayScale**.

Selection 1

1 Right-click **Surface 2** and choose **Selection**.

2 In the **Settings** window for **Selection**, locate the **Selection** section.

3 Click  **Paste Selection**.

4 In the **Paste Selection** dialog, type 3, 485, 12215 in the **Selection** text field.

5 Click **OK**.

Cut Plane 1

1 In the **Results** toolbar, click  **Cut Plane**.

2 In the **Settings** window for **Cut Plane**, locate the **Plane Data** section.

3 From the **Plane** list, choose **ZX-planes**.

Contour 1

1 In the **Model Builder** window, right-click **3D Plot Group 6** and choose **Contour**.

2 In the **Settings** window for **Contour**, locate the **Data** section.

3 From the **Dataset** list, choose **Cut Plane 1**.

4 Locate the **Expression** section. In the **Expression** text field, type $20 \cdot \log_{10}(\text{emw}.\text{normE} + 1e-5)$.

Adding $1e-5$ to the log expression improves the color variation in the contour plot.

5 Locate the **Levels** section. In the **Total levels** text field, type 100.

6 In the **3D Plot Group 6** toolbar, click  **Plot**.

See [Figure 3](#) to compare the reproduced plot.

Port Probe

The S_{11} value in the table should be around -10 dB.