



Model created in COMSOL Multiphysics 6.4

Simulating Antenna Crosstalk on an Airplane's Fuselage

Introduction

Antenna crosstalk, or co-site interference, is problematic when multiple antennas are used on a single large platform. In this example, the interference between two identical antennas at VHF frequency is studied with an S-parameter analysis of different configurations of a receiving antenna installed on an airplane fuselage. The 2D and 3D far-field radiation patterns of a transmitting antenna are computed and the lit and shadow areas on the airplane surface are also visualized.

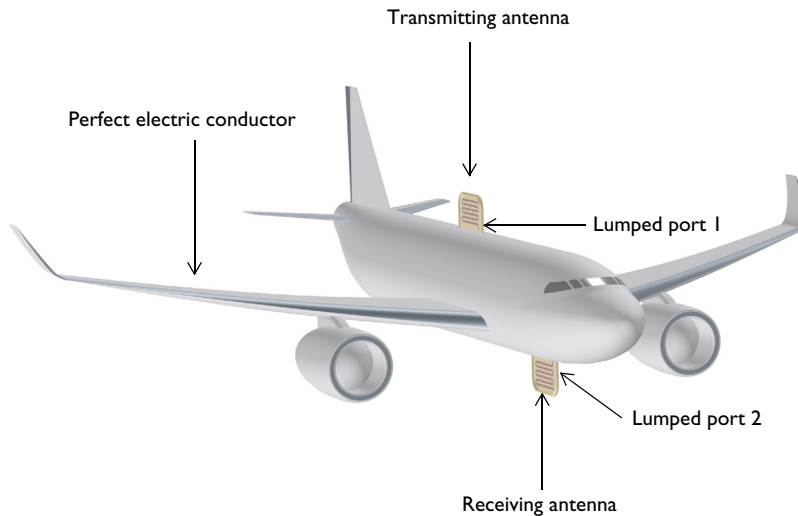

Figure 1: An airplane with ~20 m length of fuselage is simply depicted as an all-metallic structure except for the antenna enclosure. The surrounding air domain and perfectly matched layers are not shown.

Model Definition

The airplane is composed of two parts: a simplified metallic body and two antennas on its fuselage. All metal surfaces are modeled as perfect electric conductor (PEC). The PEC condition is automatically applied to all exterior boundaries. Removing the airplane body causes its surfaces to become effectively exterior and the PEC condition is applied by default. The antenna is made out of very thin metal strips inserted inside a dielectric ($\epsilon_r = 4.3$) block. The antenna is miniaturized with a meander line design, which decreases the antenna input impedance. To match the initial low input impedance with regard to

conventional 50Ω , a folded monopole antenna (effectively a folded dipole) on a large ground plane method is used.

The entire airplane is enclosed by a spherical air domain which is finished with perfectly matched layers on the outermost parts. This mimics the antenna testing in infinite free space without causing unwanted reflection from the outer walls.

On each antenna, a lumped port is assigned on the gap between the metallic meander line and the airplane's fuselage. S-parameters are calculated from two lumped ports that show the antenna matching properties as well as the amount of interference in the given configuration.

The receiving antenna is located at three different places on the bottom side of the fuselage, and this location variation is modeled using a parametric sweep.

Results and Discussion

Figure 2 shows the E-field norm distribution in dB scale on a vertical cut plane at each location of the receiving antenna. Regardless of the location, the antenna on the bottom side of the fuselage is reacting to the field from the transmitting antenna on the top of the fuselage, so there is no complete shadow region with any of these three locations.

To identify lit and shadow areas, the E-field norm is visualized on the airplane surface in Figure 3. By adjusting the display color range, the difference between the two categories is emphasized. The areas around turbines, rear wings, and some regions of the bottom side of the main wings and fuselage are relatively less affected by the transmitting antenna.

See Figure 4 where the E-field norm is plotted in dB scale while the receiving antenna on the fuselage bottom is moved from the rear to the front side. From the XY view, the shadow area is visible, located at the rear end of the fuselage bottom.

The amount of interference can be also quantitatively described in terms of S-parameters (Table 1) and the computed S_{21} gives a more clear clue about where to install the second antenna to minimize the crosstalk to the first antenna.

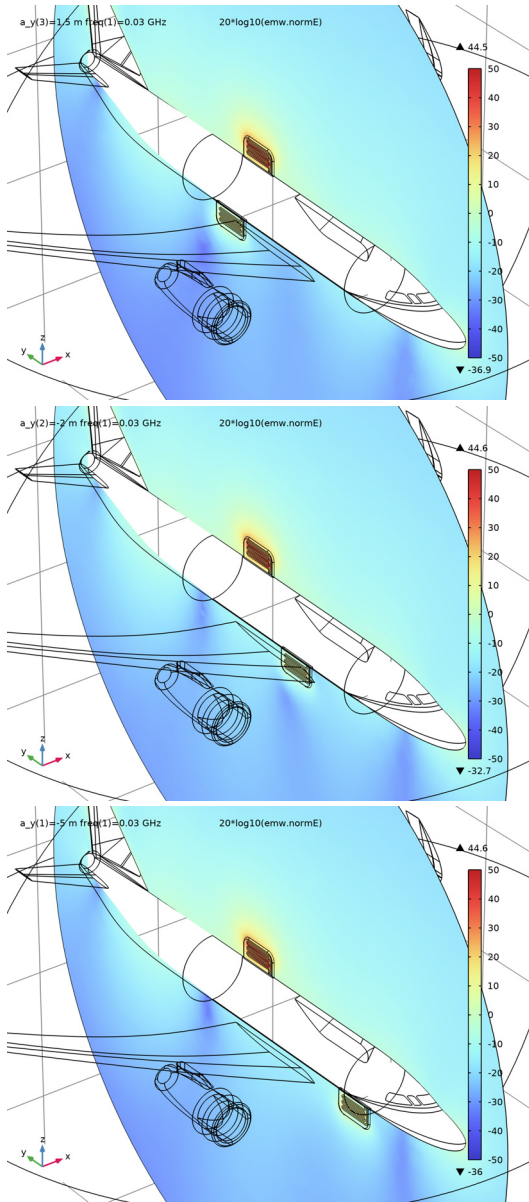

Figure 2: E-field norm plot in dB scale on the yz-plane with the receiving antenna at locations on the fuselage bottom from the rear to front side.

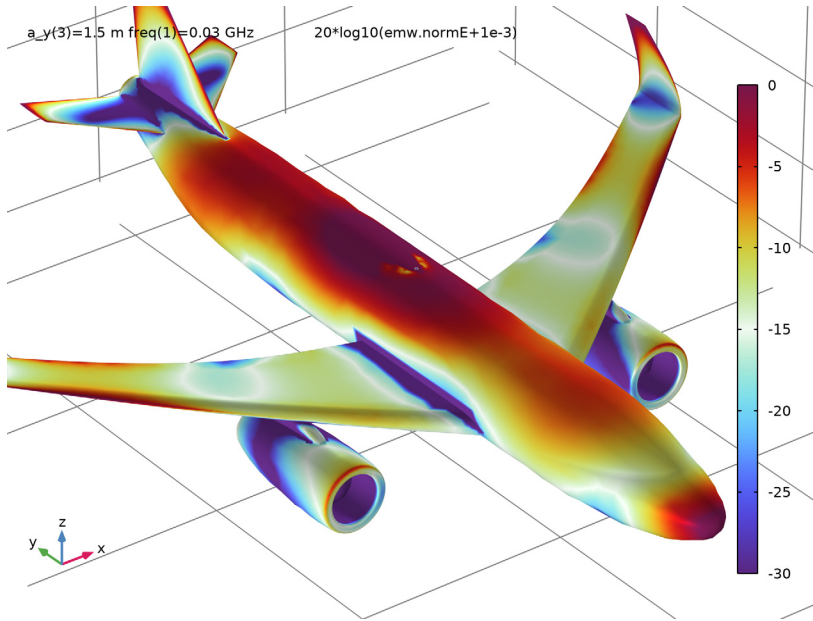

Figure 3: E-field norm on the airplane surface. The visualization color range is adjusted to emphasize the lit and shadow regions due to the transmitting antenna.

TABLE I: S-PARAMETERS.

POSITION	FRONT	MIDDLE	REAR
S_{11}	< -10 dB	< -10 dB	< -10 dB
S_{21}	-20.5 dB	-23.9 dB	-21.2 dB

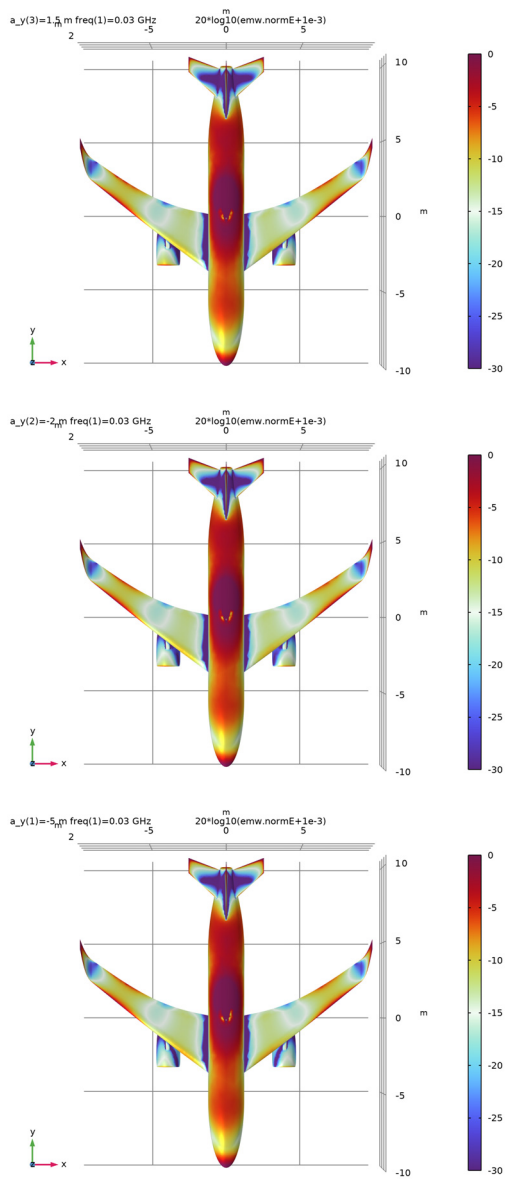

Figure 4: E-field norm plot in dB scale from the XY view with the receiving antenna on the fuselage bottom from the rear to front side. The shadow area is located on the rear side.

Application Library path: RF_Module/EMI_EMG_Applications/
airplane_antenna_crosstalk



Modeling Instructions

From the **File** menu, choose **New**.

NEW

In the **New** window, click  **Model Wizard**.

MODEL WIZARD

- 1 In the **Model Wizard** window, click  **3D**.
- 2 In the **Select Physics** tree, select **Radio Frequency > Electromagnetic Waves, Frequency Domain (emw)**.
- 3 Click **Add**.
- 4 Click  **Study**.
- 5 In the **Select Study** tree, select **General Studies > Frequency Domain**.
- 6 Click  **Done**.

STUDY I

Step 1: Frequency Domain

Define the study frequency ahead of performing any frequency-dependent operation such as building mesh. The physics-controlled mesh uses the specified frequency value.

- 1 In the **Model Builder** window, under **Study I** click **Step 1: Frequency Domain**.
- 2 In the **Settings** window for **Frequency Domain**, locate the **Study Settings** section.
- 3 In the **Frequencies** text field, type 30[MHz].

GLOBAL DEFINITIONS

Parameters I



- 1 In the **Model Builder** window, under **Global Definitions** click **Parameters I**.
- 2 In the **Settings** window for **Parameters**, locate the **Parameters** section.

3 In the table, enter the following settings:

Name	Expression	Value	Description
a_y	-5[m]	-5 m	Second antenna location

GEOMETRY I

Import 1 (imp1)

- 1 In the **Geometry** toolbar, click  **Import**.
- 2 In the **Settings** window for **Import**, locate the **Source** section.
- 3 Click  **Browse**.
- 4 Browse to the model's Application Libraries folder and double-click the file airplane_antenna_crosstalk_body.mphbin.
- 5 Click  **Import**.

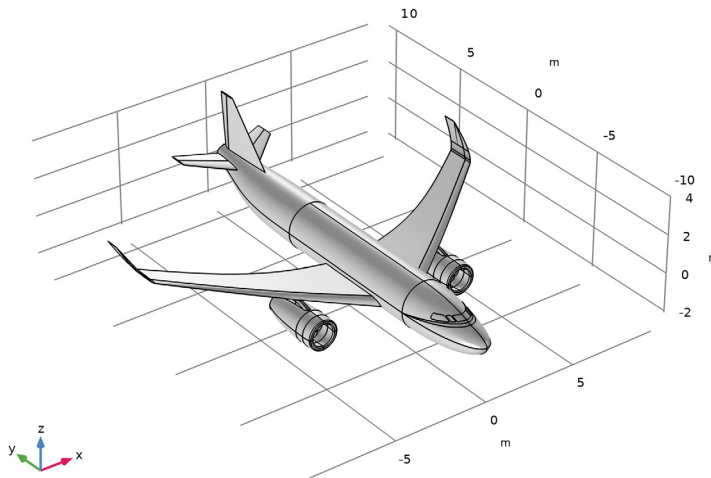

Import 2 (imp2)

- 1 In the **Geometry** toolbar, click  **Import**.
- 2 In the **Settings** window for **Import**, locate the **Source** section.
- 3 Click  **Browse**.
- 4 Browse to the model's Application Libraries folder and double-click the file airplane_antenna_crosstalk_radiation.mphbin.

5 Click  **Import**.

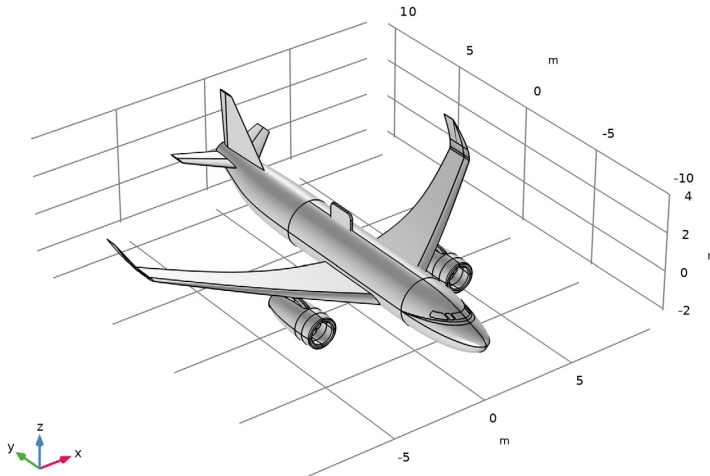

6 Click the  **Wireframe Rendering** button in the **Graphics** toolbar.

Mirror 1 (mir1)

- 1 In the **Geometry** toolbar, click  **Transforms** and choose **Mirror**.
- 2 Select the object **imp2** only.
- 3 In the **Settings** window for **Mirror**, locate the **Input** section.
- 4 Select the **Keep input objects** checkbox.

Move 1 (mov1)

- 1 In the **Geometry** toolbar, click  **Transforms** and choose **Move**.
- 2 Select the object **mir1** only.
- 3 In the **Settings** window for **Move**, locate the **Displacement** section.
- 4 In the **y** text field, type `a_y`.

Sphere 1 (sph1)



- 1 In the **Geometry** toolbar, click  **Sphere**.
- 2 In the **Settings** window for **Sphere**, locate the **Size** section.
- 3 In the **Radius** text field, type 13.

4 Click to expand the **Layers** section. In the table, enter the following settings:

Layer name	Thickness (m)
Layer 1	$c_const/30[\text{MHz}]/10$

A perfectly matched layer (PML) will be configured in this layer. A PML with a thickness of approximately 0.1 wavelengths works well for an incident wave that is normal to the surface.

Difference 1 (dif1)

- 1 In the **Geometry** toolbar, click  **Booleans and Partitions** and choose **Difference**.
- 2 Select the objects **imp2**, **mov1**, and **sph1** only.
- 3 In the **Settings** window for **Difference**, locate the **Difference** section.
- 4 Click to select the  **Activate Selection** toggle button for **Objects to subtract**.
- 5 Select the object **imp1** only.
- 6 Select the **Keep objects to subtract** checkbox.
- 7 Click  **Build All Objects**.

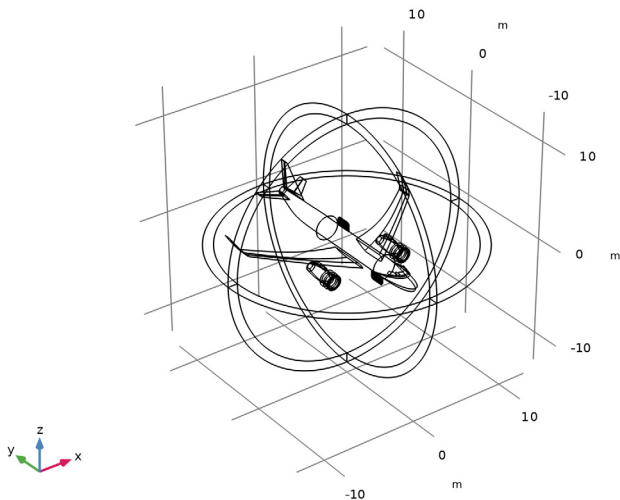

Disable the analysis of the geometry as the remaining small geometric details can be kept.

- 8 In the **Model Builder** window, click **Geometry 1**.
- 9 In the **Settings** window for **Geometry**, locate the **Cleanup** section.

10 Clear the **Automatic detection of small details** checkbox.

DEFINITIONS

Perfectly Matched Layer 1 (pml1)



- 1 In the **Definitions** toolbar, click  **Perfectly Matched Layer**.
- 2 Select Domains 1–4 and 9–12 only.
- 3 In the **Settings** window for **Perfectly Matched Layer**, locate the **Geometry** section.
- 4 From the **Type** list, choose **Spherical**.

Explicit 1

- 1 In the **Definitions** toolbar, click  **Explicit**.
- 2 Select Domain 6 only.
- 3 In the **Settings** window for **Explicit**, locate the **Output Entities** section.
- 4 From the **Output entities** list, choose **Adjacent boundaries**.

ELECTROMAGNETIC WAVES, FREQUENCY DOMAIN (EMW)

Perfect Electric Conductor 2

- 1 In the **Physics** toolbar, click  **Boundaries** and choose **Perfect Electric Conductor**.
- 2 Click the  **Zoom In** button in the **Graphics** toolbar.
- 3 Select Boundaries 140 and 148 only.

Perfect Electric Conductor 3

- 1 In the **Physics** toolbar, click  **Domains** and choose **Perfect Electric Conductor**.
- 2 Select Domain 6 only.

Lumped Port 1

- 1 In the **Physics** toolbar, click  **Boundaries** and choose **Lumped Port**.
- 2 Select Boundary 149 only.

For the first port, wave excitation is **on** by default.



Lumped Port 2

- 1 In the **Physics** toolbar, click  **Boundaries** and choose **Lumped Port**.
- 2 Select Boundary 141 only.

Far-Field Domain 1

In the **Physics** toolbar, click  **Domains** and choose **Far-Field Domain**.

ADD MATERIAL

- 1 In the **Materials** toolbar, click  **Add Material** to open the **Add Material** window.
- 2 Go to the **Add Material** window.
- 3 In the tree, select **Built-in > Air**.
- 4 Click the **Add to Component** button in the window toolbar.
- 5 In the **Materials** toolbar, click  **Add Material** to close the **Add Material** window.

MATERIALS

Material 2 (mat2)

- 1 In the **Model Builder** window, under **Component 1 (comp1)** right-click **Materials** and choose **Blank Material**.
- 2 Select Domains 7 and 8 only.
- 3 In the **Settings** window for **Material**, locate the **Material Contents** section.
- 4 In the table, enter the following settings:

Property	Variable	Value	Unit	Property group
Relative permittivity	epsilon_iso ; epsilon_rii = epsilon_iso, epsilon_rij = 0	4.3	l	Basic
Relative permeability	mu_iso ; mu_rii = mu_iso, mu_rij = 0	1	l	Basic
Electric conductivity	sigma_iso ; sigma_ii = sigma_iso, sigma_ij = 0	0	S/m	Basic

MESH 1

- 1 In the **Model Builder** window, under **Component 1 (comp1)** click **Mesh 1**.
- 2 In the **Settings** window for **Mesh**, locate the **Physics-Controlled Mesh** section.
- 3 From the **Element size** list, choose **Coarse**.
- 4 Locate the **Electromagnetic Waves, Frequency Domain (emw)** section. Select the **Refine conductive edges** checkbox.

Information 1

- 1 In the **Mesh** toolbar, click  **Build Mesh**.
- 2 Click the  **Zoom Out** button in the **Graphics** toolbar.

DEFINITIONS

Hide for Physics 1

- 1 In the **Model Builder** window, right-click **View 1** and choose **Hide for Physics**.
- 2 In the **Settings** window for **Hide for Physics**, locate the **Geometric Entity Selection** section.
- 3 From the **Geometric entity level** list, choose **Boundary**.
- 4 Click  **Paste Selection**.
- 5 In the **Paste Selection** dialog, type 6, 10, 108, 115, 124, 127, 129 in the **Selection** text field.
- 6 Click **OK**.

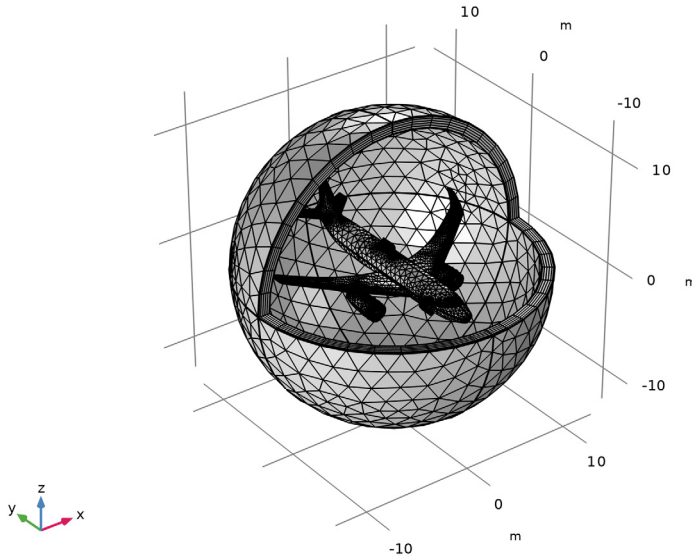

MESH 1

In the **Model Builder** window, under **Component 1 (comp1)** click **Mesh 1**.



STUDY 1

Parametric Sweep

- 1 In the **Study** toolbar, click  **Parametric Sweep**.
- 2 In the **Settings** window for **Parametric Sweep**, locate the **Study Settings** section.
- 3 Click  **Add**.
- 4 In the table, enter the following settings:

Parameter name	Parameter value list	Parameter unit
a_y (Second antenna location)	-5 -2 1.5	m



With this parameter, the receiving antenna on the fuselage bottom is relocated in this order: front, middle, and rear position.

Step 1: Frequency Domain

In the **Study** toolbar, click  **Compute**.

RESULTS

Multislice 1

- 1 In the **Model Builder** window, expand the **Electric Field (emw)** node, then click **Multislice 1**.
- 2 In the **Settings** window for **Multislice**, locate the **Multiplane Data** section.
- 3 Find the **Y-planes** subsection. In the **Planes** text field, type 0.
- 4 Find the **Z-planes** subsection. In the **Planes** text field, type 0.
- 5 Locate the **Expression** section. In the **Expression** text field, type $20 \cdot \log_{10}(\text{emw}.\text{normE})$.
- 6 Click to expand the **Range** section. Select the **Manual color range** checkbox.
- 7 In the **Minimum** text field, type -50.
- 8 In the **Maximum** text field, type 50.
- 9 In the **Electric Field (emw)** toolbar, click  **Plot**.
- 10 Click the  **Zoom In** button in the **Graphics** toolbar.

Electric Field (emw)

- 1 In the **Model Builder** window, click **Electric Field (emw)**.
- 2 In the **Settings** window for **3D Plot Group**, locate the **Data** section.
- 3 From the **Parameter value (a_y (m))** list, choose **-2**.
- 4 In the **Electric Field (emw)** toolbar, click  **Plot**.

5 From the **Parameter value (a_y (m))** list, choose **-5**.

6 In the **Electric Field (emw)** toolbar, click  **Plot**.

Compare the plot for each different location of the receiving antenna with [Figure 2](#).

S-Parameter (emw)

In the **Model Builder** window, click **S-Parameter (emw)**.

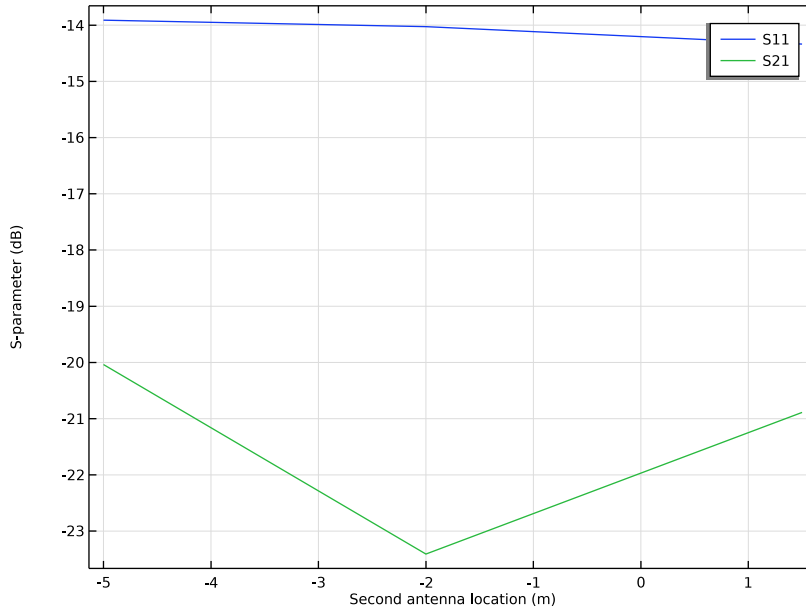

Reflection Graph 1

1 In the **Model Builder** window, expand the **Results > Smith Plot (emw)** node, then click **Reflection Graph 1**.

2 In the **Settings** window for **Reflection Graph**, click to expand the **Title** section.

3 In the **Title** text area, type **Reflection Graph: S-parameter by the second antenna location (m)**.

4 Click to expand the **Coloring and Style** section. Find the **Line markers** subsection. From the **Marker** list, choose **Cycle**.

5 From the **Positioning** list, choose **Interpolated**.

Color Expression 1

1 In the **Model Builder** window, expand the **Reflection Graph 1** node.

2 Right-click **Color Expression 1** and choose **Delete**.

Reflection Graph 1

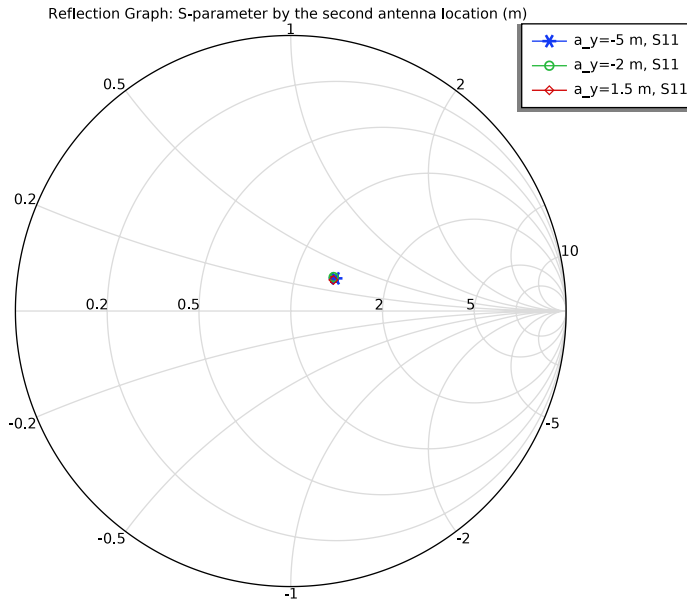

Multislice 1

- 1 In the **Model Builder** window, expand the **Results > Electric Field, Logarithmic (emw)** node, then click **Multislice 1**.
- 2 In the **Settings** window for **Multislice**, click to expand the **Range** section.
- 3 Select the **Manual color range** checkbox.
- 4 In the **Minimum** text field, type 0.01.

5 In the **Electric Field, Logarithmic (emw)** toolbar, click  **Plot**.

a_y(3)=1.5 m freq(1)=0.03 GHz Surface: 1 (1) Surface: 1 (1) Multislice: Electric field norm (V/m) Surface:
Electric field norm (V/m)

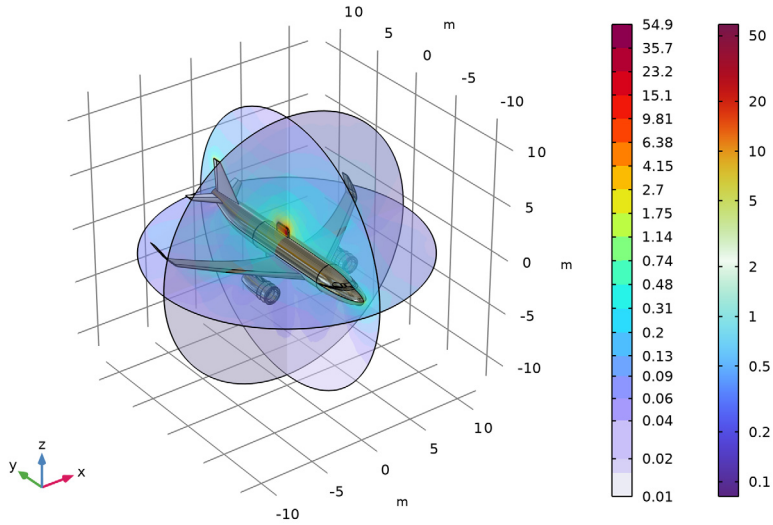

Radiation Pattern I

I In the **Model Builder** window, expand the **Results > 2D Far Field (emw)** node, then click **Radiation Pattern I**.

2 In the **2D Far Field (emw)** toolbar, click  **Plot**.

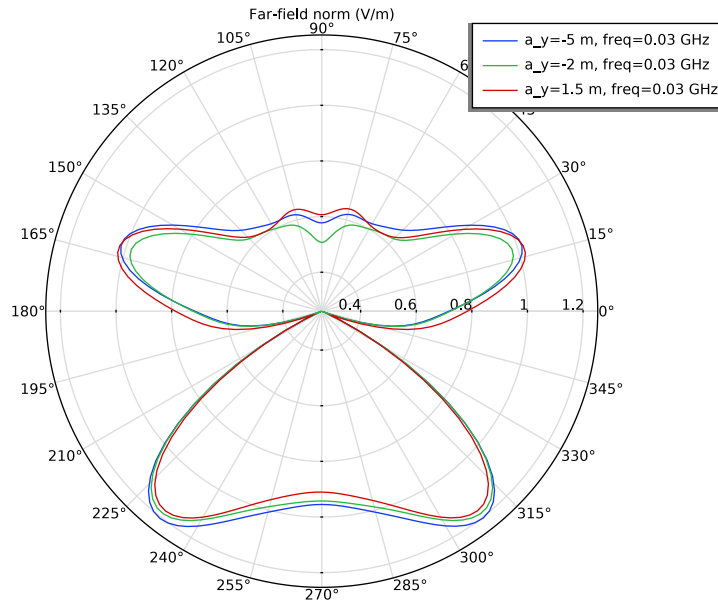

Radiation Pattern I

- 1 In the **Model Builder** window, expand the **Results > 3D Far Field, Gain (emw)** node, then click **Radiation Pattern I**.
- 2 In the **Settings** window for **Radiation Pattern**, locate the **Evaluation** section.
- 3 Find the **Angles** subsection. In the **Number of elevation angles** text field, type 90.
- 4 In the **Number of azimuth angles** text field, type 90.

5 In the **3D Far Field, Gain (emw)** toolbar, click  **Plot**.

a_y(3)=1.5 m freq(1)=0.03 GHz

Realized far-field gain, dBi (dB)

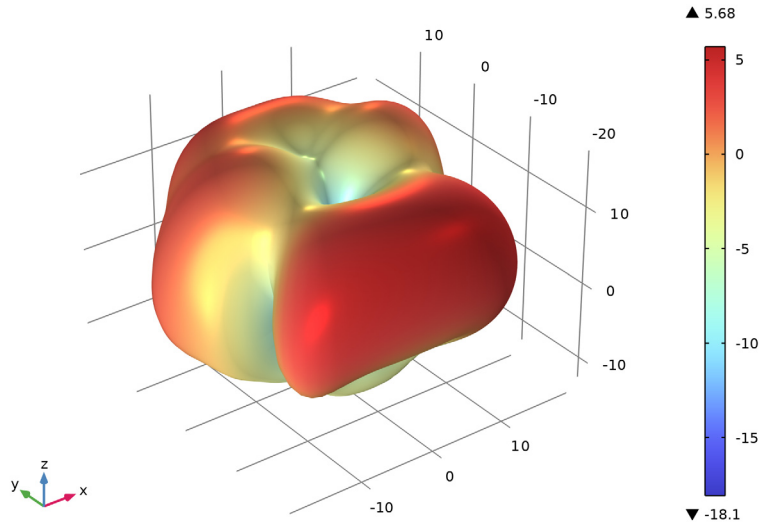

Electric Field on Surface

- 1 In the **Results** toolbar, click  **3D Plot Group**.
- 2 In the **Settings** window for **3D Plot Group**, type **Electric Field on Surface** in the **Label** text field.
- 3 Locate the **Data** section. From the **Dataset** list, choose **Study 1/ Parametric Solutions 1 (sol2)**.
- 4 Locate the **Plot Settings** section. Clear the **Plot dataset edges** checkbox.

Surface 1

Right-click **Electric Field on Surface** and choose **Surface**.

Selection 1

- 1 In the **Model Builder** window, right-click **Surface 1** and choose **Selection**.
- 2 In the **Settings** window for **Selection**, locate the **Selection** section.
- 3 From the **Selection** list, choose **Explicit 1**.

Surface 1

- 1 In the **Model Builder** window, click **Surface 1**.
- 2 In the **Settings** window for **Surface**, locate the **Expression** section.

- 3 In the **Expression** text field, type $20 * \log_{10}(emw.normE+1e-3)$.
 - 4 Click to expand the **Range** section. Select the **Manual color range** checkbox.
 - 5 In the **Minimum** text field, type -30.
 - 6 In the **Maximum** text field, type 0.
 - 7 Locate the **Coloring and Style** section. From the **Color table** list, choose **Dipole**.
 - 8 In the **Electric Field on Surface** toolbar, click  **Plot**.
- See [Figure 3](#) to compare the reproduced plot.

S-Parameter (emw)



The S_{11} value should be below -10 dB for all three antenna locations.

Based on the S_{21} values, the best location for the least interference can be identified.

Surface 1

Click the  **Zoom In** button in the **Graphics** toolbar, a couple of times to get a view of the fuselage bottom.

Electric Field on Surface

- 1 In the **Model Builder** window, click **Electric Field on Surface**.
- 2 In the **Settings** window for **3D Plot Group**, locate the **Data** section.
- 3 From the **Parameter value (a_y (m))** list, choose **-2**.
- 4 In the **Electric Field on Surface** toolbar, click  **Plot**.
- 5 From the **Parameter value (a_y (m))** list, choose **-5**.
- 6 In the **Electric Field on Surface** toolbar, click  **Plot**.

The cold spot for the least interference can be identified from the plot shown in [Figure 4](#).

Electric Field in Air Domain

- 1 In the **Results** toolbar, click  **3D Plot Group**.
- 2 In the **Settings** window for **3D Plot Group**, type Electric Field in Air Domain in the **Label** text field.
- 3 Locate the **Data** section. From the **Dataset** list, choose **Study 1/ Parametric Solutions 1 (sol2)**.
- 4 Locate the **Plot Settings** section. Clear the **Plot dataset edges** checkbox.

Isosurface 1

- 1 Right-click **Electric Field in Air Domain** and choose **Isosurface**.

- 2 In the **Settings** window for **Isosurface**, locate the **Expression** section.
- 3 In the **Expression** text field, type $20 * \log_{10}(\text{emw}.\text{normE} + 1e - 2)$.
- 4 Locate the **Levels** section. In the **Total levels** text field, type 25.
- 5 Locate the **Coloring and Style** section. From the **Color table** list, choose **Cividis**.
The color table **Cividis** is optimized for viewing scalar data. The color table benefits people both with and without color vision deficiency.
- 6 From the **Color table transformation** list, choose **Nonlinear**.
- 7 Set the **Color calibration parameter** value to **-1.5**.

Filter 1

- 1 Right-click **Isosurface 1** and choose **Filter**.
- 2 In the **Settings** window for **Filter**, locate the **Element Selection** section.
- 3 In the **Logical expression for inclusion** text field, type $x > 0$.

Selection 1

- 1 In the **Model Builder** window, right-click **Isosurface 1** and choose **Selection**.
- 2 Select Domain 5 only.
- 3 Click the  **Go to Default View** button in the **Graphics** toolbar.

Transparency 1

- 1 Right-click **Isosurface 1** and choose **Transparency**.
- 2 Click the  **Zoom In** button in the **Graphics** toolbar.

Surface 1

In the **Model Builder** window, right-click **Electric Field in Air Domain** and choose **Surface**.

Selection 1

- 1 In the **Model Builder** window, right-click **Surface 1** and choose **Selection**.
- 2 In the **Settings** window for **Selection**, locate the **Selection** section.
- 3 From the **Selection** list, choose **Explicit 1**.

Material Appearance 1

- 1 In the **Model Builder** window, right-click **Surface 1** and choose **Material Appearance**.
- 2 In the **Settings** window for **Material Appearance**, locate the **Appearance** section.
- 3 From the **Appearance** list, choose **Custom**.
- 4 From the **Material type** list, choose **Plastic (shiny)**.

5 In the **Electric Field in Air Domain** toolbar, click  **Plot**.

