



Model created in COMSOL Multiphysics 6.4

# Microwave Cavity Plasma Reactor

## Introduction

---

This tutorial shows how to prepare a model of a hydrogen plasma sustained in a microwave cavity at moderate pressures. The model is based on the work in [Ref. 1](#) and solves the plasma transport equations fully coupled with Maxwell's equations, fluid flow, and heat transfer. A microwave cylindrical chamber contains a bell jar where a hydrogen plasma is created. The reactor is carefully designed so that the electric field has its maximum intensity above a substrate and much lower intensity at the bell jar boundary. This is important in order for the plasma to keep its maximum density in the substrate region even at high power.

---

**Note:** The model requires the Plasma Module and the RF Module.

---

## Model Definition

---

Electron transport is modeled by solving the continuity equation, the momentum equation under the drift-diffusion approximation, and the mean electron energy equation (for detailed information on electron transport, see *Theory for the Drift Diffusion Interface* in the *Plasma Module User's Guide*)

$$\frac{\partial}{\partial t}(n_e) + \nabla \cdot [-n_e(\mu_e \cdot \mathbf{E}) - \mathbf{D}_e \cdot \nabla n_e] = R_e$$
$$\frac{\partial}{\partial t}(n_e) + \nabla \cdot [-n_e(\mu_e \cdot \mathbf{E}) - \mathbf{D}_e \cdot \nabla n_e] + \mathbf{E} \cdot \Gamma_e = S_{en}$$

The source coefficients in the above equations are determined by the plasma chemistry. The electron rate expression is defined as

$$R_e = N_A \sum_j \nu_{e,j} r_j$$

where  $\nu_{e,j}$  is the stoichiometric coefficient, and the reaction rate is defined as

$$r_j = k_j^f \prod_{i \in \text{react}} c_i^{-\nu_{i,j}} + k_j^r \prod_{i \in \text{prod}} c_i^{\nu_{i,j}}$$

where  $k_j^f$  is the forward rate constant and  $k_j^r$  is the reversed rate constant. Both the Electron Impact Reaction feature and Reaction feature can contribute to the electron rate

expression. However, when using the Reaction feature it is important to note that the associated electron energy gain or loss is not included in the source term of the electron mean energy equation.

The rate constants can be computed from electron impact cross-section data

$$k^f = N_A \gamma \int_0^{\infty} \epsilon \sigma(\epsilon) f(\epsilon) d\epsilon$$

where  $\gamma = (2q/m_e)^{1/2}$  (SI unit:  $C^{1/2}/kg^{1/2}$ ),  $m_e$  is the electron mass (SI unit: kg),  $\epsilon$  is the electron energy (SI unit: V),  $\sigma$  is the electron impact collision cross section (SI unit:  $m^2$ ), and  $f$  is the electron energy distribution function.

When *Townsend coefficients* are used, the reaction rate is defined as

$$r_j = \frac{\alpha_j}{N_n} |\Gamma_e| \prod_{i \neq e \in \text{react}} c_i^{-\nu_{i,j}}$$

where  $\alpha_j/N_n$  is the reduced Townsend coefficient for reaction  $j$  (SI unit:  $m^2$ ) and  $\Gamma_e$  is the electron flux as defined above (SI unit:  $1/(m^2 \cdot s)$ ). Townsend coefficients can increase the stability of the numerical scheme when the electron flux is field driven as is the case with DC discharges.

The total electron energy loss or gained is calculated by summing the collisional energy changes from all reactions defined with the Electron Impact Reaction feature as

$$S_{\text{en}} = -\sum_j r_j \Delta \epsilon_j F$$

where  $\Delta \epsilon_j$  is the energy loss from reaction  $j$  (SI unit: V) and  $F$  is the Faraday constant (SI unit: C/mol). For excitation and ionization collisions  $\Delta \epsilon_j$  corresponds to the energy of the excited state being excited/deexcited or ionized, for attachment  $\Delta \epsilon_j$  is set to zero, and for elastic collisions

$$\Delta \epsilon = 2 \frac{m_e}{m_k} \frac{3}{2} \left[ T_e (\text{eV}) - \frac{k_B}{e} T_{\text{gas}} (\text{K}) \right]$$

where  $m_e$  and  $m_k$  are the electron and heavy species mass in kg,  $T_e$  is the electron temperature in eV, and  $T_{\text{gas}}$  is the gas temperature in K.

For heavy species, the following equation is solved for the mass fraction of each species (for detailed information on the transport of the nonelectron species, see *Theory for the Heavy Species Transport Interface* in the *Plasma Module User's Guide*):

$$\rho \frac{\partial}{\partial t}(w_k) + \rho(\mathbf{u} \cdot \nabla)w_k = \nabla \cdot \mathbf{j}_k + R_k$$

The electrostatic field is computed using the following equation:

$$-\nabla \cdot \epsilon_0 \epsilon_r \nabla V = \rho$$

The space charge density  $\rho$  is automatically computed based on the plasma chemistry specified in the model using the formula

$$\rho = q \left( \sum_{k=1}^N Z_k n_k - n_e \right)$$

For detailed information about electrostatics see *Theory for the Electrostatics Interface* in the *Plasma Module User's Guide*.

In a microwave reactor, the high-frequency electric field is computed in the frequency domain through the equation

$$\nabla \times (\mu_r^{-1} \nabla \times \mathbf{E}) - k_0^2 \left( \epsilon_r - \frac{j\sigma}{\omega \epsilon_0} \right) \mathbf{E} = 0$$

The electromagnetic wave “sees” a plasma defined by the plasma conductivity in the cold plasma approximation that is set in the **Plasma Conductivity Coupling** multiphysics feature:

$$\sigma = \frac{n_e q^2}{m_e (\nu_e + j\omega)}$$

where  $n_e$  is the electron density,  $q$  is the electron charge,  $m_e$  is the electron mass,  $\nu_e$  is the collision frequency, and  $\omega$  is the angular frequency. The Joule heating term that is responsible to heat the electrons is set in the **Electron Heat Source** multiphysics feature.

The fluid flow and heat transfer in the fluid are also solved for. The gas temperature plays an important role in the reactor operation since it can significantly influence the reduced electric field  $E/N$ .

## PLASMA CHEMISTRY

The plasma chemistry is based on the simplified chemistry presented in table 4 of [Ref. 1](#) and is presented in [Table 1](#). The electron impact reactions are from [Ref. 2](#) and retrieved from [Ref. 3](#), and the rates are from [Ref. 4](#) and [Ref. 5](#). The model includes eight species:

electrons,  $H_2$ ,  $H$ ,  $H_2^+$ ,  $H^+$ ,  $H_3^+$ , and two excited states of hydrogen corresponding to the levels  $n = 2$  and  $n = 3$  that are represented by  $Hn2$  and  $Hn3$ .

TABLE I: MODELED COLLISIONS AND REACTIONS.

Reaction	Formula	Type	$\Delta\epsilon$ (eV)
1	$e+H_2 \Rightarrow e+H_2$	Elastic	-
2	$e+H_2 \Rightarrow e+H_2$	Vibrational excitation	0.516-1.5
3	$e+H_2 \Rightarrow e+2H$	Dissociation	7.93-11.72 and 17.22- 17.53
4	$e+H_2 \Rightarrow e+H_2$	Excitation	12.4-14.6
5	$e+H_2 \Rightarrow e+H+Hn2$	Dissociative excitation	14.68
6	$e+H_2 \Rightarrow e+H+Hn3$	Dissociative excitation	16.57
7	$e+H_2 \Rightarrow 2e+H_2^+$	Ionization	15.4
8	$e+H_2 \Rightarrow 2e+H+H^+$	Ionization	19
9	$e+H \Rightarrow e+H$	Elastic	-
10	$e+H \Rightarrow e+Hn2$	Excitation	10.2043
11	$e+H \Rightarrow e+Hn3$	Charge transfer	12.1
12	$e+H \Rightarrow e+H$	Excitation	12.755 and 13.0615
13	$e+H \Rightarrow 2e+H^+$	Ionization	13.6057
14	$e+H_3^+ \Rightarrow 3H$	Recombination	0
15	$e+H_2^+ \Rightarrow H+Hn2$	Recombination	0.01
16	$e+H_2^+ \Rightarrow H+Hn3$	Recombination	0.01
17	$e+H^+ \Rightarrow Hn2$	Recombination	0
18	$e+H^+ \Rightarrow Hn3$	Recombination	0
19	$Hn2+H_2 \Rightarrow H_3^++e$	Ionization	-
20	$Hn3+H_2 \Rightarrow H_3^++e$	Ionization	-
21	$H_2+H_2^+ \Rightarrow H_3^++H$	Ionization	-
22	$H_2+H_2 \Rightarrow 2H+H_2$	Dissociation	-
23	$2H+H_2 \Rightarrow H_2+H_2$	Association	-
24	$H_2+H \Rightarrow 3H$	Dissociation	-
26	$3H \Rightarrow H_2+H$	Association	-

In addition to the volume reactions, the surface reaction listed in [Table 2](#).

TABLE 2: SURFACE REACTIONS.

Reaction	Formula	Sticking coefficient
1	$H \Rightarrow 0.5H_2$	0.02
2	$Hn_2 \Rightarrow H$	1
3	$Hn_3 \Rightarrow H$	1
4	$H^+ \Rightarrow H$	1
5	$H_2^+ \Rightarrow H_2$	1
6	$H_3^+ \Rightarrow H_2 + H$	1

## *Results and Discussion*

The figures in this section present model results for a hydrogen plasma sustained at 25 kPa with 5 kW. In general, the results agree well with results presented in figure 21 and figure 22 of [Ref. 1](#). A detailed comparison is not attempted because many aspects of the models are different. The plasma chemistry is not exactly the same. Even if the reactions are mostly the same, the rates and cross sections were obtained independently. The reactor dimensions and configurations are only approximate. Additionally, there are differences in the model equations.

Using a global model fully coupled with a Boltzmann equation in the two-term approximation, the study performed in the model [Hydrogen Global Model Coupled with the Two-Term Boltzmann Equation](#) — also in the Plasma Module Application Library — showed that for main quantities like electron density, H-atom density, and gas temperature there is not a significant difference when using a computed or a Maxwellian EEDF. This justified doing the space-dependent simulations using a Maxwellian EEDF. However, in this first attempt the results were wrong in many ways. An important aspect not captured was the plasma localization at the substrate. With a Maxwellian EEDF it is very easy to ionize in regions of low electron energy and the maximum of the plasma easily moves somewhere else. Further investigations with the global model showed significant differences in results for low mean electron energies. The EEDF was then adjusted to use a generalized distribution with a power law of 1.2.

The reactor dimensions were adjusted to have high electric field intensity at the substrate and to have a minimum in reflected power without plasma. This part of the investigation is done with the Electromagnetic Waves, Frequency Domain interface only and it is not shown here. With the plasma present, the electromagnetic characteristics of the reactor change considerably. This is possible to observe in [Figure 5](#) and [Figure 6](#), which show the

S-parameter and Smith plot when increasing the power from 500 to 5000 W. Having a high-dense plasma in a considerable part of the reactor strongly increases the reflected power.

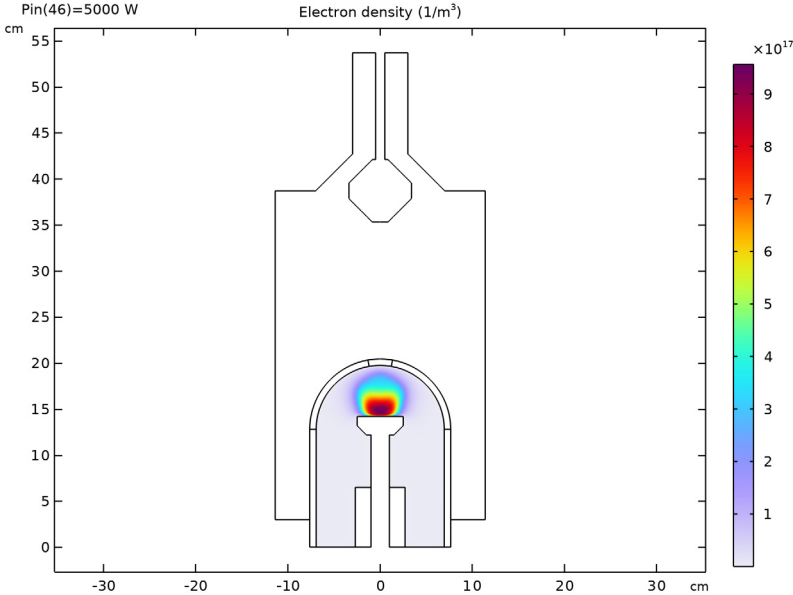
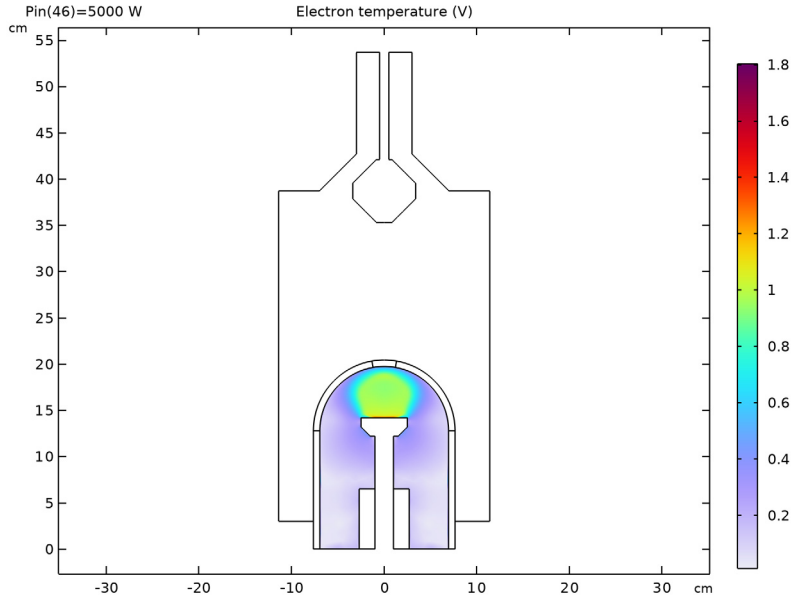
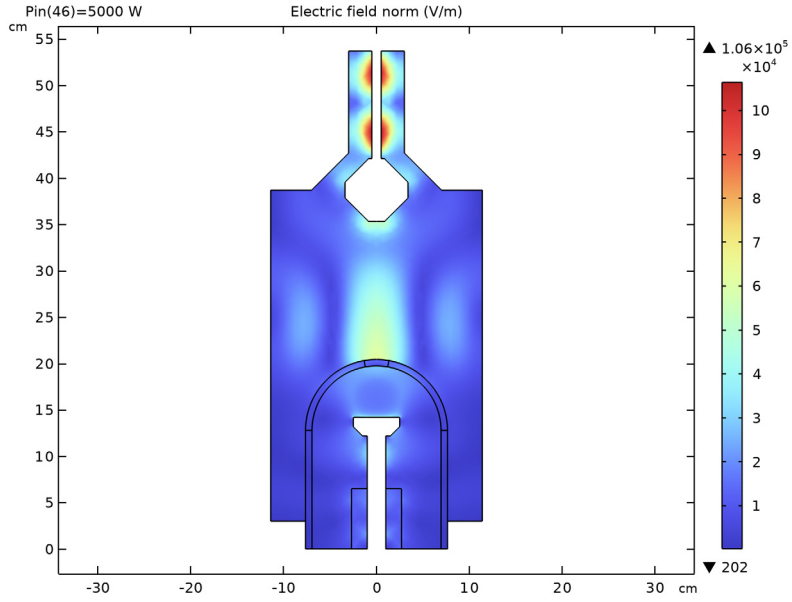

Figure 1: Electron density for a hydrogen plasma operating at 25 kPa with 5 kW of input power.



*Figure 2: Electron temperature for a hydrogen plasma operating at 25 kPa with 5 kW of input power.*



*Figure 3: RF electric field norm for a hydrogen plasma operating at 25 kPa with 5 kW of input power.*

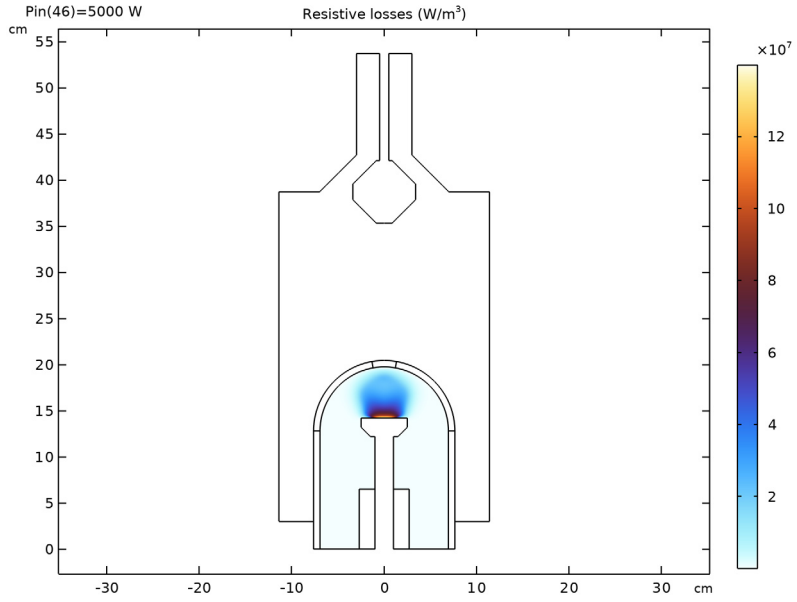

*Figure 4: RF power absorbed by electrons for a hydrogen plasma operating at 25 kPa with 5 kW of input power.*

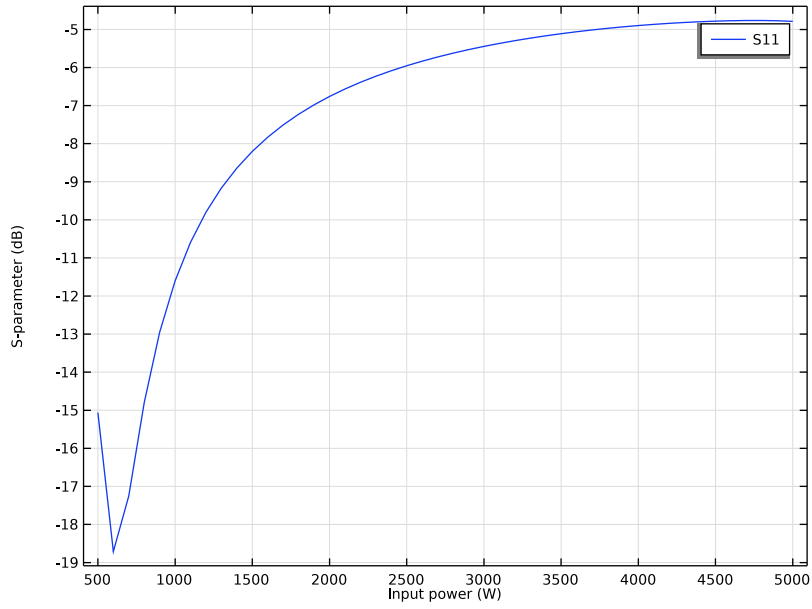
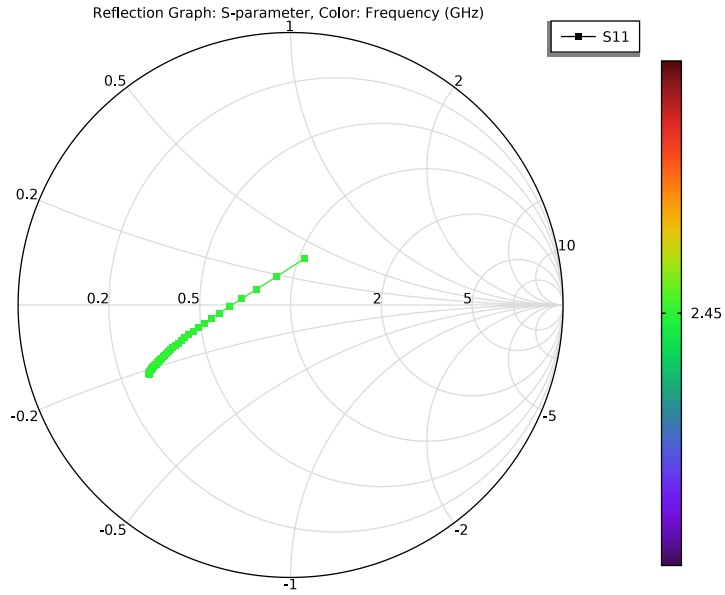
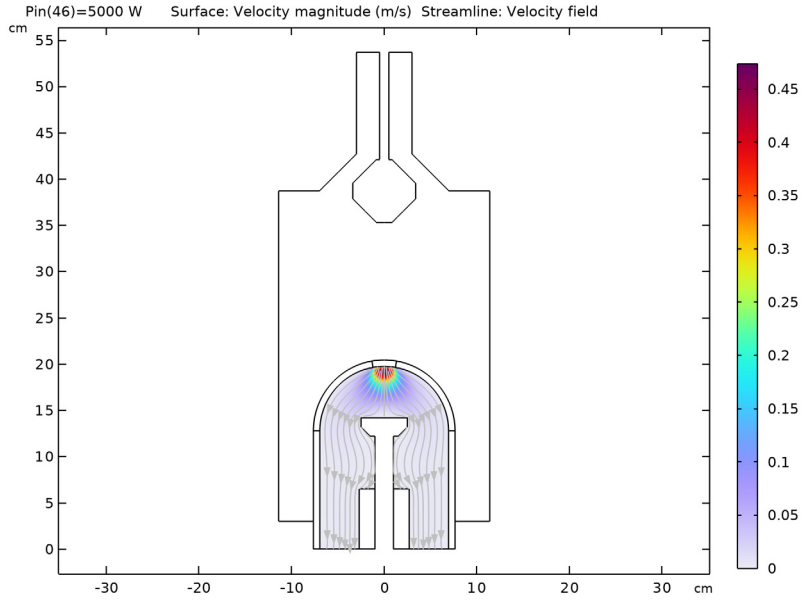

Figure 5: S-parameter as a function of the input power.



*Figure 6: Smith plot as a function of the input power. For higher powers the curve moves away from the center.*



*Figure 7: Fluid velocity for a hydrogen plasma operating at 25 kPa with 5 kW of input power.*

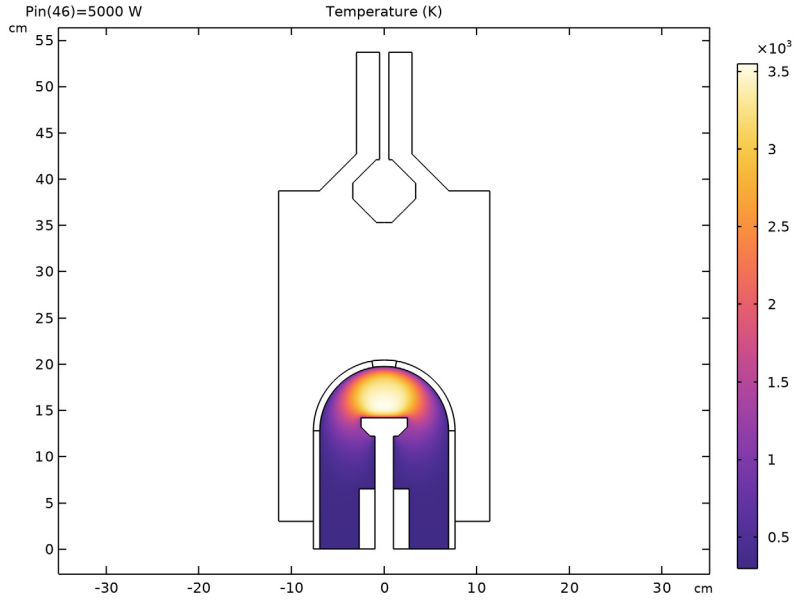

*Figure 8: Gas temperature for a hydrogen plasma operating at 25 kPa with 5 kW of input power.*

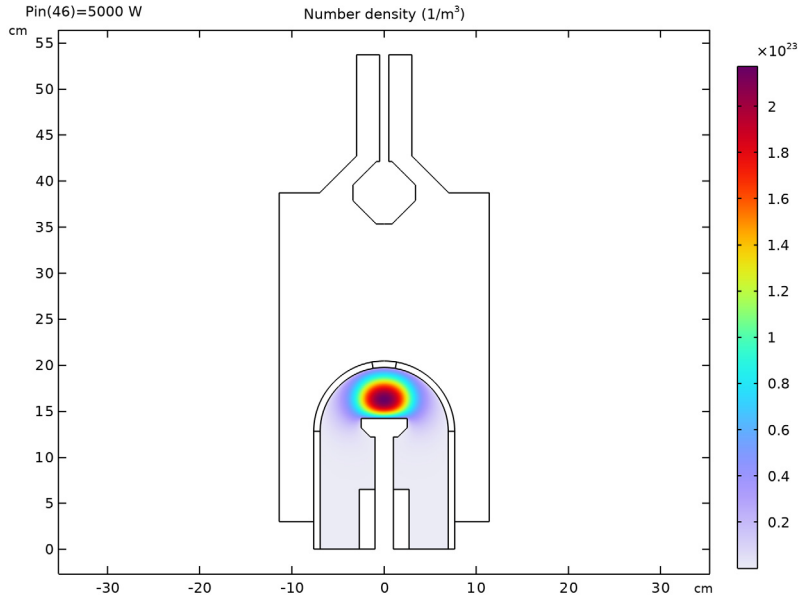

Figure 9: Number density of atomic hydrogen for a hydrogen plasma operating at 25 kPa with 5 kW of input power.

## References

1. K. Hassouni, F. Silva, and A. Gicquel, "Modelling of diamond deposition microwave cavity generated plasmas," *J. Phys. D: Appl. Phys.*, vol. 43, p. 153001, 2010.
2. L. Marques, J. Jolly, and L.L. Alves, "Capacitively Coupled Radio-Frequency Hydrogen Discharges: The Role of Kinetics," *J. Appl. Phys.*, vol. 102, p. 063305, 2007.
3. IST-Lisbon database, [www.lxcat.net](http://www.lxcat.net), retrieved 2023.
4. M. Capitelli, C.M. Ferreira, B.F. Gordiets and A.I. Osipov, *Plasma Kinetics in Atmospheric Gases*, Springer, 2000.
5. R.K. Janev; W.D. Langer; K. Evans, Jr.; and D.E. Post, Jr., *Elementary Processes in Hydrogen-Helium Plasmas*, Springer-Verlag, 1987.

---

**Application Library path:** Plasma\_Module/Wave-Heated\_Discharges/  
microwave\_cavity\_plasma

---

### *Modeling Instructions*



---

From the **File** menu, choose **New**.

#### **NEW**

In the **New** window, click  **Model Wizard**.

#### **MODEL WIZARD**

- 1 In the **Model Wizard** window, click  **2D Axisymmetric**.
- 2 In the **Select Physics** tree, select **Plasma > Nonisothermal Plasma Flow > Microwave Plasma**.
- 3 Click **Add**.
- 4 Click  **Study**.
- 5 In the **Select Study** tree, select **Preset Studies for Selected Multiphysics > Frequency-Transient**.
- 6 Click  **Done**.

Import a file with parameters to be used in the model. Most of them are used to create the reactor geometry.

#### **GLOBAL DEFINITIONS**

##### *Parameters I*

- 1 In the **Model Builder** window, under **Global Definitions** click **Parameters I**.
- 2 In the **Settings** window for **Parameters**, locate the **Parameters** section.
- 3 Click  **Load from File**.
- 4 Browse to the model's Application Libraries folder and double-click the file `microwave_cavity_plasma_parameters.txt`.

Create a profile to be used as initial conditions for the gas temperature.

## DEFINITIONS

### Variables 1

- 1 In the **Model Builder** window, under **Component 1 (comp1)** right-click **Definitions** and choose **Variables**.
- 2 In the **Settings** window for **Variables**, locate the **Variables** section.
- 3 In the table, enter the following settings:

Name	Expression	Unit	Description
r0	0[cm]	m	Maximum r-coordinate
z0	14[cm]	m	Maximum z-coordinate
prf	$\exp(-((r0-r)/4[\text{cm}])^2 - ((z0-z)/2[\text{cm}])^2)$		Initial temperature profile
Tinit	2500[K]*prf+1200[K]	K	Initial temperature

Create the geometry of the reactor. Some geometry elements are to be used later when creating the mesh.

## GEOMETRY 1

- 1 In the **Model Builder** window, under **Component 1 (comp1)** click **Geometry 1**.
- 2 In the **Settings** window for **Geometry**, locate the **Units** section.
- 3 From the **Length unit** list, choose **cm**.

### Rectangle 1 (r1)

- 1 In the **Geometry** toolbar, click  **Rectangle**.
- 2 In the **Settings** window for **Rectangle**, locate the **Size and Shape** section.
- 3 In the **Width** text field, type R0.
- 4 In the **Height** text field, type H0.

### Rectangle 2 (r2)

- 1 In the **Geometry** toolbar, click  **Rectangle**.
- 2 In the **Settings** window for **Rectangle**, locate the **Size and Shape** section.
- 3 In the **Width** text field, type S1w.
- 4 In the **Height** text field, type S1h.

### Rectangle 3 (r3)

- 1 In the **Geometry** toolbar, click  **Rectangle**.
- 2 In the **Settings** window for **Rectangle**, locate the **Size and Shape** section.

- 3 In the **Width** text field, type Shw.
- 4 In the **Height** text field, type Shh.
- 5 Locate the **Position** section. In the **z** text field, type S1h.

#### *Rectangle 4 (r4)*

- 1 In the **Geometry** toolbar, click  **Rectangle**.
- 2 In the **Settings** window for **Rectangle**, locate the **Size and Shape** section.
- 3 In the **Width** text field, type Shw.
- 4 In the **Height** text field, type 2[mm].
- 5 Locate the **Position** section. In the **z** text field, type S1h+Shh.

#### *Rectangle 5 (r5)*

- 1 In the **Geometry** toolbar, click  **Rectangle**.
- 2 In the **Settings** window for **Rectangle**, locate the **Size and Shape** section.
- 3 In the **Width** text field, type Bhw-Bth/2.
- 4 In the **Height** text field, type Bhh.
- 5 Locate the **Position** section. In the **r** text field, type R0-Bhw+Bth/2.

#### *Circular Arc 1 (ca1)*



- 1 In the **Geometry** toolbar, click  **More Primitives** and choose **Circular Arc**.
- 2 In the **Settings** window for **Circular Arc**, locate the **Center** section.
- 3 In the **z** text field, type Bz.
- 4 Locate the **Radius** section. In the **Radius** text field, type Br.

#### *Line Segment 1 (ls1)*

- 1 In the **Geometry** toolbar, click  **More Primitives** and choose **Line Segment**.
- 2 In the **Settings** window for **Line Segment**, locate the **Starting Point** section.
- 3 From the **Specify** list, choose **Coordinates**.
- 4 In the **r** text field, type Br.
- 5 In the **z** text field, type Bz.
- 6 Locate the **Endpoint** section. From the **Specify** list, choose **Coordinates**.
- 7 In the **r** text field, type R0-Bhw.

#### *Circular Arc 2 (ca2)*

- 1 In the **Geometry** toolbar, click  **More Primitives** and choose **Circular Arc**.
- 2 In the **Settings** window for **Circular Arc**, locate the **Center** section.

- 3 In the **z** text field, type Bz.
- 4 Locate the **Radius** section. In the **Radius** text field, type Br.
- 5 Locate the **Angles** section. In the **Start angle** text field, type 80.
- 6 Click the  **Zoom Extents** button in the **Graphics** toolbar.
- 7 Click  **Build All Objects**.

*Thicken 1 (th1)*

- 1 In the **Geometry** toolbar, click  **Conversions** and choose **Thicken**.
- 2 Select the objects **ca1**, **ca2**, and **ls1** only.
- 3 In the **Settings** window for **Thicken**, locate the **Options** section.
- 4 In the **Total thickness** text field, type Bth.

*Rectangle 6 (r6)*



- 1 In the **Geometry** toolbar, click  **Rectangle**.
- 2 In the **Settings** window for **Rectangle**, locate the **Size and Shape** section.
- 3 In the **Width** text field, type Cxw.
- 4 In the **Height** text field, type Cxh.
- 5 Locate the **Position** section. In the **z** text field, type H0.

*Polygon 1 (pol1)*

- 1 In the **Geometry** toolbar, click  **Polygon**.
- 2 In the **Settings** window for **Polygon**, locate the **Coordinates** section.
- 3 In the table, enter the following settings:

<b>r (cm)</b>	<b>z (cm)</b>
Cxw	H0+Th
Cxw+Tw	H0
Cxw	H0



*Union 1 (un1)*

- 1 In the **Geometry** toolbar, click  **Booleans and Partitions** and choose **Union**.
- 2 Select the objects **pol1**, **r1**, and **r6** only.
- 3 In the **Settings** window for **Union**, locate the **Union** section.
- 4 Clear the **Keep interior boundaries** checkbox.
- 5 Click  **Build All Objects**.

### Rectangle 7 (r7)

- 1 In the **Geometry** toolbar, click  **Rectangle**.
- 2 In the **Settings** window for **Rectangle**, locate the **Size and Shape** section.
- 3 In the **Width** text field, type Dw.
- 4 In the **Height** text field, type Dw.
- 5 Locate the **Position** section. From the **Base** list, choose **Center**.
- 6 In the **z** text field, type H0.
- 7 Locate the **Rotation Angle** section. In the **Rotation** text field, type 45.



### Chamfer 1 (cha1)

- 1 In the **Geometry** toolbar, click  **Chamfer**.
- 2 Click the  **Zoom Extents** button in the **Graphics** toolbar.
- 3 On the object **r7**, select Points 1–4 only.
- 4 In the **Settings** window for **Chamfer**, locate the **Distance** section.
- 5 In the **Distance from vertex** text field, type Dcut.

### Rectangle 8 (r8)

- 1 In the **Geometry** toolbar, click  **Rectangle**.
- 2 In the **Settings** window for **Rectangle**, locate the **Size and Shape** section.
- 3 In the **Width** text field, type Cx<sub>w</sub>.
- 4 In the **Height** text field, type Cx<sub>h</sub>.
- 5 Locate the **Position** section. In the **z** text field, type H0.



### Difference 1 (dif1)

- 1 In the **Geometry** toolbar, click  **Booleans and Partitions** and choose **Difference**.
- 2 Select the object **uni1** only.
- 3 In the **Settings** window for **Difference**, locate the **Difference** section.
- 4 Click to select the  **Activate Selection** toggle button for **Objects to subtract**.
- 5 Select the objects **cha1**, **r2**, **r3**, **r5**, and **r8** only.



### Circular Arc 3 (ca3)

- 1 In the **Geometry** toolbar, click  **More Primitives** and choose **Circular Arc**.
- 2 In the **Settings** window for **Circular Arc**, locate the **Center** section.
- 3 In the **z** text field, type Shh+S1h.
- 4 Locate the **Radius** section. In the **Radius** text field, type 3[cm].

### *Line Segment 2 (ls2)*

- 1 In the **Geometry** toolbar, click  **More Primitives** and choose **Line Segment**.
- 2 In the **Settings** window for **Line Segment**, locate the **Starting Point** section.
- 3 Click to select the  **Activate Selection** toggle button for **Start vertex**.
- 4 On the object **ca3**, select Point 1 only.
- 5 Locate the **Endpoint** section. Click to select the  **Activate Selection** toggle button for **End vertex**.
- 6 On the object **r4**, select Point 2 only.

### *Line Segment 3 (ls3)*

- 1 In the **Geometry** toolbar, click  **More Primitives** and choose **Line Segment**.
- 2 On the object **ls2**, select Point 1 only.
- 3 In the **Settings** window for **Line Segment**, locate the **Endpoint** section.
- 4 Click to select the  **Activate Selection** toggle button for **End vertex**.
- 5 On the object **th1(3)**, select Point 2 only.



### *Chamfer 2 (cha2)*

- 1 In the **Geometry** toolbar, click  **Chamfer**.
- 2 On the object **dif1**, select Point 9 only.
- 3 In the **Settings** window for **Chamfer**, locate the **Distance** section.
- 4 In the **Distance from vertex** text field, type 1 [cm].

### *Rectangle 9 (r9)*

- 1 In the **Geometry** toolbar, click  **Rectangle**.
- 2 In the **Settings** window for **Rectangle**, locate the **Size and Shape** section.
- 3 In the **Width** text field, type dielw.
- 4 In the **Height** text field, type dielh.
- 5 Locate the **Position** section. In the **r** text field, type S1w.

### *Mesh Control Edges 1 (mce1)*

- 1 In the **Geometry** toolbar, click  **Virtual Operations** and choose **Mesh Control Edges**.
- 2 On the object **fin**, select Boundaries 4, 22, 23, 26, and 38 only.
- 3 In the **Geometry** toolbar, click  **Build All**.
- 4 Click the  **Zoom Extents** button in the **Graphics** toolbar.

## THE PLASMA CHEMISTRY IMPORT FEATURE

The next steps have instructions to use the **Plasma Chemistry Import** feature to import a file that automatically creates the hydrogen plasma chemistry.



The following is set or created automatically:

- a Species properties using **Preset species data**
- b Reaction group features for hydrogen
- c Surface reactions

The documentation accompanying the **Plasma Chemistry Import** feature contains more information about the file structure and what can be set automatically.



## PLASMA (PLAS)

*Plasma Chemistry Import 1*

- 1 In the **Physics** toolbar, click  **Global** and choose **Plasma Chemistry Import**.
- 2 In the **Settings** window for **Plasma Chemistry Import**, locate the **Plasma Chemistry Import** section.
- 3 Click  **Browse**.
- 4 Browse to the model's Application Libraries folder and double-click the file `H2_plasma_chemistry.txt`.
- 5 Click  **Import**.

Define material properties for air and quartz. The plasma conductivity is computed in the **Plasma Conductivity Coupling** multiphysics feature and overrides its definition set in the material properties.

## ADD MATERIAL

- 1 In the **Materials** toolbar, click  **Add Material** to open the **Add Material** window.
- 2 Go to the **Add Material** window.
- 3 In the tree, select **Built-in > Air**.
- 4 Click the **Add to Component** button in the window toolbar.
- 5 In the tree, select **Built-in > Glass (quartz)**.
- 6 Click the **Add to Component** button in the window toolbar.
- 7 In the **Materials** toolbar, click  **Add Material** to close the **Add Material** window.

## MATERIALS

*Glass (quartz) (mat2)*

Select Domains 2 and 4–6 only.

## MATERIALS

In the **Model Builder** window, collapse the **Component 1 (comp1) > Materials** node.

Set some properties of the plasma model.

## PLASMA (PLAS)

- 1 In the **Model Builder** window, under **Component 1 (comp1)** click **Plasma (plas)**.
- 2 In the **Settings** window for **Plasma**, locate the **Transport Settings** section.
- 3 Select the **Full expression for diffusivity** checkbox.
- 4 Select the **Mixture diffusion correction** checkbox.
- 5 Locate the **Plasma Properties** section. Select the **Use reduced electron transport properties** checkbox.
- 6 Locate the **Electron Energy Distribution Function Settings** section. From the **Electron energy distribution function** list, choose **Generalized**.
- 7 In the *g* text field, type 1.2.
- 8 Locate the **Domain Selection** section. Click  **Clear Selection**.
- 9 Select Domain 1 only.

*Group - Species*

Set initial conditions for the heavy species.

*Species: H2*

- 1 In the **Model Builder** window, expand the **Component 1 (comp1) > Plasma (plas) > Group - Species** node, then click **Species: H2**.
- 2 In the **Settings** window for **Species**, locate the **Species Formula** section.
- 3 Select the **From mass constraint** checkbox.

*Species: H*

- 1 In the **Model Builder** window, click **Species: H**.
- 2 In the **Settings** window for **Species**, locate the **General Parameters** section.
- 3 In the  $x_0$  text field, type 1E-5.

*Species: Hn3*

- 1 In the **Model Builder** window, click **Species: Hn3**.

2 In the **Settings** window for **Species**, locate the **General Parameters** section.

3 In the  $x_0$  text field, type 1E-10.

*Species: H<sub>2</sub><sup>+</sup>*

1 In the **Model Builder** window, click **Species: H<sub>2</sub><sup>+</sup>**.

2 In the **Settings** window for **Species**, locate the **General Parameters** section.

3 In the  $n_0$  text field, type 1E7[1/m<sup>3</sup>].

*Species: H<sup>+</sup>*

1 In the **Model Builder** window, click **Species: H<sup>+</sup>**.

2 In the **Settings** window for **Species**, locate the **General Parameters** section.

3 In the  $n_0$  text field, type 1E7[1/m<sup>3</sup>].

*Species: H<sub>3</sub><sup>+</sup>*

1 In the **Model Builder** window, click **Species: H<sub>3</sub><sup>+</sup>**.

2 In the **Settings** window for **Species**, locate the **Species Formula** section.

3 Select the **Initial value from electroneutrality constraint** checkbox.

*Group - Species*

In the **Model Builder** window, collapse the **Component 1 (comp1) > Plasma (plas) > Group - Species** node.

Set boundaries for surface reactions.

## DEFINITIONS

*Walls*

1 In the **Definitions** toolbar, click  **Explicit**.

2 Select Domain 1 only.

3 In the **Settings** window for **Explicit**, locate the **Output Entities** section.

4 From the **Output entities** list, choose **Adjacent boundaries**.

5 In the **Label** text field, type Walls.

*Walls neutrals*

1 In the **Definitions** toolbar, click  **Explicit**.

2 In the **Settings** window for **Explicit**, type Walls neutrals in the **Label** text field.

3 Locate the **Input Entities** section. From the **Geometric entity level** list, choose **Boundary**.

4 Select Boundaries 2, 13–15, 17–19, 24, 32, and 34 only.

## PLASMA (PLAS)

1:  $H \Rightarrow 0.5H_2$

- 1 In the **Model Builder** window, expand the **Component 1 (comp1) > Plasma (plas) > Group - Surface Reactions** node, then click **1:  $H \Rightarrow 0.5H_2$** .
- 2 In the **Settings** window for **Surface Reaction**, locate the **Boundary Selection** section.
- 3 From the **Selection** list, choose **Walls neutrals**.

2:  $Hn_2 \Rightarrow H$

- 1 In the **Model Builder** window, click **2:  $Hn_2 \Rightarrow H$** .
- 2 In the **Settings** window for **Surface Reaction**, locate the **Boundary Selection** section.
- 3 From the **Selection** list, choose **Walls neutrals**.

3:  $Hn_3 \Rightarrow H$

- 1 In the **Model Builder** window, click **3:  $Hn_3 \Rightarrow H$** .
- 2 In the **Settings** window for **Surface Reaction**, locate the **Boundary Selection** section.
- 3 From the **Selection** list, choose **Walls neutrals**.

4:  $H+ \Rightarrow H$

- 1 In the **Model Builder** window, click **4:  $H+ \Rightarrow H$** .
- 2 In the **Settings** window for **Surface Reaction**, locate the **Boundary Selection** section.
- 3 From the **Selection** list, choose **Walls**.

5:  $H_2+ \Rightarrow H_2$

- 1 In the **Model Builder** window, click **5:  $H_2+ \Rightarrow H_2$** .
- 2 In the **Settings** window for **Surface Reaction**, locate the **Boundary Selection** section.
- 3 From the **Selection** list, choose **Walls**.

6:  $H_3+ \Rightarrow H_2+H$

- 1 In the **Model Builder** window, click **6:  $H_3+ \Rightarrow H_2+H$** .
- 2 In the **Settings** window for **Surface Reaction**, locate the **Boundary Selection** section.
- 3 From the **Selection** list, choose **Walls**.

### *Group - Surface Reactions*

In the **Model Builder** window, collapse the **Component 1 (comp1) > Plasma (plas) > Group - Surface Reactions** node.

Set an **Outflow** boundary condition for neutrals only. Ions are assumed to be neutralized at the outlet.

### *Outflow 1*

- 1 In the **Physics** toolbar, click  **Boundaries** and choose **Outflow**.
- 2 Select Boundary 20 only.

## **PLASMA (PLAS)**

### *Wall 1*

- 1 In the **Physics** toolbar, click  **Boundaries** and choose **Wall**.
- 2 In the **Settings** window for **Wall**, locate the **Boundary Selection** section.
- 3 From the **Selection** list, choose **Walls**.

### *Ground 1*

- 1 In the **Physics** toolbar, click  **Boundaries** and choose **Ground**.
- 2 Select Boundaries 2, 13–15, 17–20, 24, 32, and 34 only.

## **LAMINAR FLOW (SPF)**

- 1 In the **Model Builder** window, under **Component 1 (comp1)** click **Laminar Flow (spf)**.
- 2 In the **Settings** window for **Laminar Flow**, locate the **Domain Selection** section.
- 3 Click  **Clear Selection**.
- 4 Select Domain 1 only.
- 5 Locate the **Physical Model** section. In the  $p_{\text{ref}}$  text field, type p0.

### *Inlet 1*

- 1 In the **Physics** toolbar, click  **Boundaries** and choose **Inlet**.
- 2 Select Boundary 32 only.
- 3 In the **Settings** window for **Inlet**, locate the **Boundary Condition** section.
- 4 From the list, choose **Mass flow**.
- 5 Locate the **Mass Flow** section. From the **Mass flow type** list, choose **Standard flow rate (SCCM)**.
- 6 In the  $Q_{\text{sccm}}$  text field, type Qs.

### *Outlet 1*

- 1 In the **Physics** toolbar, click  **Boundaries** and choose **Outlet**.
- 2 Select Boundary 20 only.

## **LAMINAR FLOW (SPF)**

In the **Model Builder** window, collapse the **Component 1 (comp1) > Laminar Flow (spf)** node.

## HEAT TRANSFER IN FLUIDS (HT)

- 1 In the **Model Builder** window, under **Component 1 (comp1)** click **Heat Transfer in Fluids (ht)**.
- 2 In the **Settings** window for **Heat Transfer in Fluids**, locate the **Domain Selection** section.
- 3 Click  **Clear Selection**.
- 4 Select Domain 1 only.

### *Initial Values 1*

- 1 In the **Model Builder** window, under **Component 1 (comp1)** > **Heat Transfer in Fluids (ht)** click **Initial Values 1**.
- 2 In the **Settings** window for **Initial Values**, locate the **Initial Values** section.
- 3 In the  $T$  text field, type  $T_{init}$ .

### *Temperature 1*

- 1 In the **Physics** toolbar, click  **Boundaries** and choose **Temperature**.
- 2 Select Boundaries 2, 15, 17, and 18 only.
- 3 In the **Settings** window for **Temperature**, locate the **Temperature** section.
- 4 In the  $T_0$  text field, type 1200[K].

### *Temperature 2*

- 1 In the **Physics** toolbar, click  **Boundaries** and choose **Temperature**.
- 2 Select Boundaries 13, 14, and 19 only.
- 3 In the **Settings** window for **Temperature**, locate the **Temperature** section.
- 4 In the  $T_0$  text field, type 300[K].

### *Heat Flux 1*

- 1 In the **Physics** toolbar, click  **Boundaries** and choose **Heat Flux**.
- 2 In the **Settings** window for **Heat Flux**, locate the **Heat Flux** section.
- 3 From the **Flux type** list, choose **Convective heat flux**.
- 4 In the  $h$  text field, type 200.
- 5 In the  $T_{ext}$  text field, type 300[K].
- 6 Select Boundaries 24, 32, and 34 only.

### *Outflow 1*

- 1 In the **Physics** toolbar, click  **Boundaries** and choose **Outflow**.
- 2 Select Boundary 20 only.

## HEAT TRANSFER IN FLUIDS (HT)

In the **Model Builder** window, collapse the **Component 1 (comp1)** > **Heat Transfer in Fluids (ht)** node.

## ELECTROMAGNETIC WAVES, FREQUENCY DOMAIN (EMW)

In the **Model Builder** window, under **Component 1 (comp1)** click **Electromagnetic Waves, Frequency Domain (emw)**.

### Port 1

- 1 In the **Physics** toolbar, click  **Boundaries** and choose **Port**.
- 2 Select Boundary 8 only.
- 3 In the **Settings** window for **Port**, locate the **Port Properties** section.
- 4 From the **Type of port** list, choose **Coaxial**.
- 5 In the  $P_{in}$  text field, type  $P_{in}$ .

## ELECTROMAGNETIC WAVES, FREQUENCY DOMAIN (EMW)

In the **Model Builder** window, collapse the **Component 1 (comp1)** > **Electromagnetic Waves, Frequency Domain (emw)** node.

The fluid velocity, pressure, and temperature are also linked to the plasma model making it fully self-consistent.

## PLASMA (PLAS)

### Plasma Model 1

- 1 In the **Model Builder** window, under **Component 1 (comp1)** > **Plasma (plas)** click **Plasma Model 1**.
- 2 In the **Settings** window for **Plasma Model**, locate the **Electron Density and Energy** section.
- 3 In the  $\mu_e N_n$  text field, type  $1.4E24[1/(V*m*s)]$ .

## PLASMA (PLAS)

In the **Model Builder** window, collapse the **Component 1 (comp1)** > **Plasma (plas)** node.

Create a mesh that is fine enough in the plasma region, specially at the subtract surface, and coarse elsewhere.

## MESH 1

### Edge 1

- 1 In the **Mesh** toolbar, click  **More Generators** and choose **Edge**.

2 Select Boundary 32 only.

#### *Size 1*

- 1 Right-click **Edge 1** and choose **Size**.
- 2 In the **Settings** window for **Size**, locate the **Element Size** section.
- 3 From the **Calibrate for** list, choose **Fluid dynamics**.
- 4 From the **Predefined** list, choose **Extra fine**.

#### *Free Triangular 1*

- 1 In the **Mesh** toolbar, click  **Free Triangular**.
- 2 In the **Settings** window for **Free Triangular**, click to expand the **Control Entities** section.
- 3 From the **Smooth across removed control entities** list, choose **Off**.

#### *Size 1*

- 1 Right-click **Free Triangular 1** and choose **Size**.
- 2 In the **Settings** window for **Size**, locate the **Element Size** section.
- 3 From the **Predefined** list, choose **Extra fine**.
- 4 Locate the **Geometric Entity Selection** section. From the **Geometric entity level** list, choose **Domain**.
- 5 Select Domains 2, 3, 5, and 6 only.

#### *Size 2*

- 1 In the **Model Builder** window, right-click **Free Triangular 1** and choose **Size**.
- 2 In the **Settings** window for **Size**, locate the **Geometric Entity Selection** section.
- 3 From the **Geometric entity level** list, choose **Domain**.
- 4 Select Domain 7 only.
- 5 Locate the **Element Size** section. From the **Calibrate for** list, choose **Plasma**.
- 6 From the **Predefined** list, choose **Extremely fine**.
- 7 Click the **Custom** button.
- 8 Locate the **Element Size Parameters** section.
- 9 Select the **Maximum element size** checkbox. In the associated text field, type 0.15.

#### *Size 3*

- 1 Right-click **Free Triangular 1** and choose **Size**.
- 2 In the **Settings** window for **Size**, locate the **Geometric Entity Selection** section.
- 3 From the **Geometric entity level** list, choose **Domain**.

- 4 Select Domain 8 only.
- 5 Locate the **Element Size** section. From the **Calibrate for** list, choose **Plasma**.
- 6 From the **Predefined** list, choose **Extremely fine**.
- 7 Click the **Custom** button.
- 8 Locate the **Element Size Parameters** section.
- 9 Select the **Maximum element size** checkbox. In the associated text field, type 0.25.

#### *Size 4*

- 1 Right-click **Free Triangular 1** and choose **Size**.
- 2 In the **Settings** window for **Size**, locate the **Geometric Entity Selection** section.
- 3 From the **Geometric entity level** list, choose **Domain**.
- 4 Select Domain 9 only.
- 5 Locate the **Element Size** section. From the **Calibrate for** list, choose **Plasma**.
- 6 From the **Predefined** list, choose **Extremely fine**.
- 7 Click the **Custom** button.
- 8 Locate the **Element Size Parameters** section.
- 9 Select the **Maximum element size** checkbox. In the associated text field, type 1.5.

#### *Size 5*

- 1 Right-click **Free Triangular 1** and choose **Size**.
- 2 In the **Settings** window for **Size**, locate the **Element Size** section.
- 3 Click the **Custom** button.
- 4 Locate the **Element Size Parameters** section.
- 5 Select the **Maximum element size** checkbox. In the associated text field, type 0.025.
- 6 Locate the **Geometric Entity Selection** section. From the **Geometric entity level** list, choose **Domain**.
- 7 Select Domain 1 only.

#### *Boundary Layers 1*

- 1 In the **Mesh** toolbar, click  **Boundary Layers**.
- 2 In the **Settings** window for **Boundary Layers**, click to expand the **Transition** section.
- 3 Clear the **Smooth transition to interior mesh** checkbox.
- 4 Click to expand the **Corner Settings** section. Locate the **Domain Selection** section. From the **Geometric entity level** list, choose **Domain**.

5 Select Domains 1 and 7–9 only.

#### *Boundary Layer Properties*



- 1 In the **Model Builder** window, click **Boundary Layer Properties**.
- 2 In the **Settings** window for **Boundary Layer Properties**, locate the **Layers** section.
- 3 In the **Number of layers** text field, type 3.
- 4 Select Boundaries 13–15, 17–19, 24, and 34 only.
- 5 In the **Model Builder** window, right-click **Mesh 1** and choose **Build All**.

First, solve a **Frequency-Transient** study for an input power of 500 W and without the fluid flow.

After, use the solutions from the previous study as initial conditions of a **Frequency-Stationary** study to ramp the power up to 5000 W.

### **STUDY 1**

#### *Step 1: Frequency–Transient*

- 1 In the **Model Builder** window, under **Study 1** click **Step 1: Frequency–Transient**.
- 2 In the **Settings** window for **Frequency–Transient**, locate the **Physics and Variables Selection** section.
- 3 In the **Solve for** column of the table, under **Component 1 (comp1)**, clear the checkbox for **Laminar Flow (spf)**.
- 4 Locate the **Study Settings** section. Click  **Range**.
- 5 In the **Range** dialog, choose **Logarithmic** from the **Entry method** list.
- 6 In the **Start** text field, type  $1e-9$ .
- 7 In the **Stop** text field, type 100.
- 8 In the **Steps per decade** text field, type 3.
- 9 Click **Replace**.
- 10 In the **Settings** window for **Frequency–Transient**, locate the **Study Settings** section.
- 11 In the **Output times** text field, type  $0 \cdot 10^{\{\text{range}(\log_{10}(1.0e-9), 1/3, \log_{10}(100))\}}$ .
- 12 In the **Frequency** text field, type  $f_0$ .
- 13 In the **Study** toolbar, click  **Get Initial Value**.

## RESULTS

*Electric Field (emw), Electric Potential (plas), Electron Density (plas), Electron Temperature (plas), Temperature (ht)*

- 1 In the **Model Builder** window, under **Results**, Ctrl-click to select **Electron Density (plas)**, **Electron Temperature (plas)**, **Electric Potential (plas)**, **Temperature (ht)**, and **Electric Field (emw)**.
- 2 Right-click and choose **Group**.

*Pin=500 W, Without Fluid Flow*

In the **Settings** window for **Group**, type Pin=500 W, Without Fluid Flow in the **Label** text field.



### **PIN=500 W, WITHOUT FLUID FLOW**

- 1 In the **Model Builder** window, click **Study I**.
- 2 In the **Settings** window for **Study**, type Pin=500 W, Without Fluid Flow in the **Label** text field.

*Step 1: Frequency–Transient*



- 1 In the **Model Builder** window, under **Pin=500 W, Without Fluid Flow** click **Step 1: Frequency–Transient**.
- 2 In the **Settings** window for **Frequency–Transient**, click to expand the **Results While Solving** section.
- 3 Select the **Plot** checkbox.
- 4 From the **Update at** list, choose **Time steps taken by solver**.
- 5 In the **Study** toolbar, click  **Compute**.

### **ADD STUDY**

- 1 In the **Home** toolbar, click  **Add Study** to open the **Add Study** window.
- 2 Go to the **Add Study** window.
- 3 Find the **Studies** subsection. In the **Select Study** tree, select **Preset Studies for Selected Multiphysics > Frequency–Stationary**.
- 4 Click the **Add Study** button in the window toolbar.
- 5 In the **Home** toolbar, click  **Add Study** to close the **Add Study** window.

## STUDY 2

### Step 1: Frequency–Stationary

- 1 In the **Settings** window for **Frequency–Stationary**, locate the **Study Settings** section.
- 2 In the **Frequency** text field, type  $f_0$ .
- 3 Click to expand the **Values of Dependent Variables** section. Find the **Initial values of variables solved for** subsection. From the **Settings** list, choose **User controlled**.
- 4 From the **Method** list, choose **Solution**.
- 5 From the **Study** list, choose **Pin=500 W, Without Fluid Flow, Frequency–Transient**.
- 6 Click to expand the **Study Extensions** section. Select the **Auxiliary sweep** checkbox.
- 7 Click **+ Add**.
- 8 Click  **Range**.
- 9 In the **Range** dialog, type 500 in the **Start** text field.
- 10 In the **Step** text field, type 100.
- 11 In the **Stop** text field, type 5000.
- 12 Click **Replace**.
- 13 In the **Settings** window for **Frequency–Stationary**, locate the **Study Extensions** section.
- 14 From the **Run continuation for** list, choose **No parameter**.
- 15 From the **Reuse solution from previous step** list, choose **Yes**.
- 16 In the **Study** toolbar, click  **Get Initial Value**.

## RESULTS

*Electric Field (emw) I, Electric Potential (plas) I, Electron Density (plas) I, Electron Temperature (plas) I, Pressure (spf), S-Parameter (emw), Smith Plot (emw), Temperature (ht) I, Velocity (spf), Velocity, 3D (spf)*

- 1 In the **Model Builder** window, under **Results**, Ctrl-click to select **Electron Density (plas) I**, **Electron Temperature (plas) I**, **Electric Potential (plas) I**, **Velocity (spf)**, **Pressure (spf)**, **Velocity, 3D (spf)**, **Temperature (ht) I**, **Electric Field (emw) I**, **S-Parameter (emw)**, and **Smith Plot (emw)**.

- 2 Right-click and choose **Group**.

*Pin=500 To 5000 W*

In the **Settings** window for **Group**, type Pin=500 To 5000 W in the **Label** text field.

## **PIN=500 TO 5000 W**

- 1 In the **Model Builder** window, click **Study 2**.
- 2 In the **Settings** window for **Study**, type Pin=500 To 5000 W in the **Label** text field.

### *Step 1: Frequency–Stationary*

- 1 In the **Model Builder** window, under **Pin=500 To 5000 W** click **Step 1: Frequency–Stationary**.
- 2 In the **Settings** window for **Frequency–Stationary**, click to expand the **Results While Solving** section.
- 3 Select the **Plot** checkbox.
- 4 In the table, enter the following settings:

<b>Plot group</b>	<b>Plot window</b>
Electron Density (plas) I	Graphics

- 5 In the **Study** toolbar, click  **Compute**.

Add a mirror data set to better visualize the results.

## **RESULTS**

### *Mirror 2D 1*

- 1 In the **Model Builder** window, expand the **Results > Datasets** node.
- 2 Right-click **Results > Datasets** and choose **More 2D Datasets > Mirror 2D**.
- 3 In the **Settings** window for **Mirror 2D**, locate the **Data** section.
- 4 From the **Dataset** list, choose **Pin=500 To 5000 W/Solution 2 (sol2)**.
- 5 Click to expand the **Advanced** section. Find the **Space variables** subsection. Select the **Remove elements on the symmetry axis** checkbox.

### *Electron Density (plas) I*

- 1 In the **Model Builder** window, under **Results > Pin=500 To 5000 W** click **Electron Density (plas) I**.
- 2 In the **Settings** window for **2D Plot Group**, locate the **Data** section.
- 3 From the **Dataset** list, choose **Mirror 2D I**.
- 4 In the **Electron Density (plas) I** toolbar, click  **Plot**.

### *Electron Temperature (plas) I*

- 1 In the **Model Builder** window, click **Electron Temperature (plas) I**.
- 2 In the **Settings** window for **2D Plot Group**, locate the **Data** section.

- 3 From the **Dataset** list, choose **Mirror 2D I**.
- 4 In the **Electron Temperature (plas) I** toolbar, click  **Plot**.

#### *Electric Potential (plas) I*

- 1 In the **Model Builder** window, click **Electric Potential (plas) I**.
- 2 In the **Settings** window for **2D Plot Group**, locate the **Data** section.
- 3 From the **Dataset** list, choose **Mirror 2D I**.
- 4 In the **Electric Potential (plas) I** toolbar, click  **Plot**.

#### *Velocity (spf)*

- 1 In the **Model Builder** window, click **Velocity (spf)**.
- 2 In the **Settings** window for **2D Plot Group**, locate the **Data** section.
- 3 From the **Dataset** list, choose **Mirror 2D I**.
- 4 In the **Velocity (spf)** toolbar, click  **Plot**.

#### *Surface*

- 1 In the **Model Builder** window, expand the **Velocity (spf)** node, then click **Surface**.
- 2 In the **Settings** window for **Surface**, locate the **Coloring and Style** section.
- 3 From the **Color table** list, choose **Prism**.

#### *Streamline I*

- 1 In the **Model Builder** window, right-click **Velocity (spf)** and choose **Streamline**.
- 2 In the **Settings** window for **Streamline**, locate the **Expression** section.
- 3 In the **x-component** text field, type *u*.
- 4 In the **y-component** text field, type *w*.
- 5 Locate the **Streamline Positioning** section. From the **Positioning** list, choose **Uniform density**.
- 6 Locate the **Coloring and Style** section. Find the **Point style** subsection. From the **Type** list, choose **Arrow**.
- 7 From the **Color** list, choose **Gray**.
- 8 Locate the **Streamline Positioning** section. In the **Density level** text field, type 7.7.
- 9 In the **Velocity (spf)** toolbar, click  **Plot**.

#### *Electric Field (emw) I*

- 1 In the **Model Builder** window, under **Results > Pin=500 To 5000 W** click **Electric Field (emw) I**.

- 2 In the **Settings** window for **2D Plot Group**, locate the **Data** section.
- 3 From the **Dataset** list, choose **Mirror 2D I**.
- 4 In the **Electric Field (emw) I** toolbar, click  **Plot**.

#### *Temperature, 2D*

- 1 In the **Results** toolbar, click  **2D Plot Group**.
- 2 In the **Settings** window for **2D Plot Group**, type Temperature, 2D in the **Label** text field.
- 3 Locate the **Data** section. From the **Dataset** list, choose **Mirror 2D I**.
- 4 From the **Parameter value (Pin (W))** list, choose **5000**.

#### *Surface I*

- 1 Right-click **Temperature, 2D** and choose **Surface**.
- 2 In the **Settings** window for **Surface**, locate the **Expression** section.
- 3 In the **Expression** text field, type T.
- 4 Locate the **Coloring and Style** section. From the **Color table** list, choose **HeatCameraLight**.
- 5 In the **Temperature, 2D** toolbar, click  **Plot**.

#### *H Number Density*

- 1 In the **Results** toolbar, click  **2D Plot Group**.
- 2 In the **Settings** window for **2D Plot Group**, type H Number Density in the **Label** text field.
- 3 Locate the **Data** section. From the **Dataset** list, choose **Mirror 2D I**.
- 4 From the **Parameter value (Pin (W))** list, choose **5000**.

#### *Surface I*

- 1 Right-click **H Number Density** and choose **Surface**.
- 2 In the **Settings** window for **Surface**, locate the **Expression** section.
- 3 In the **Expression** text field, type pLas.n\_wH.
- 4 In the **H Number Density** toolbar, click  **Plot**.

#### *Power Absorbed*

- 1 In the **Results** toolbar, click  **2D Plot Group**.
- 2 In the **Settings** window for **2D Plot Group**, type Power Absorbed in the **Label** text field.
- 3 Locate the **Data** section. From the **Dataset** list, choose **Mirror 2D I**.
- 4 From the **Parameter value (Pin (W))** list, choose **5000**.

### *Surface 1*

- 1 Right-click **Power Absorbed** and choose **Surface**.
- 2 In the **Settings** window for **Surface**, locate the **Expression** section.
- 3 In the **Expression** text field, type `emw.Qrh`.
- 4 Locate the **Coloring and Style** section. From the **Color table** list, choose **ThermalWave**.

### *Selection 1*

- 1 Right-click **Surface 1** and choose **Selection**.
- 2 Select Domain 1 only.
- 3 In the **Power Absorbed** toolbar, click  **Plot**.