



Model created in COMSOL Multiphysics 6.4

Convective Flow in a Heat Exchanger Plate

Introduction

An evenly distributed flow is necessary to achieve good thermal performance in plate heat exchangers. The flow distribution can be controlled by the design of the inlet and outlet manifolds that connect the plate channels.

Modeling the detailed flow within the channels of a plate heat exchanger can be computationally costly, or even prohibitive. However, it is often sufficient to describe the flow with a lumped pipe flow model. This way the computational time and memory requirements can be significantly reduced. The model presented here shows such an approach where a Pipe Flow interface, solving for the velocity and pressure in the plate channels, is coupled to a Laminar Flow interface, that solves for the 3D flow and pressure in the inflow and an outflow manifolds.



Figure 1: Plate heat exchanger assembly with stacked plates. Image courtesy of Varem S.p.a.

Model Definition

Figure 2 shows the model geometry. The inlet and outlet manifolds are 2 mm wide, 1 mm high, and 85 mm long. The microchannels have a square cross section with a side of 1 mm. They are drawn as edges in the 3D geometry.

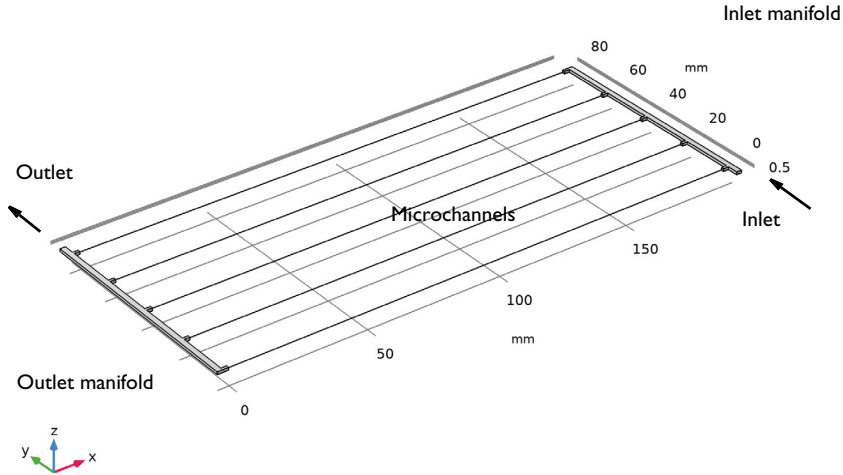

Figure 2: Five microchannels, inlet and outlet manifold.

DOMAIN EQUATIONS

The fluid properties of water are used in both interfaces.

Inlet and Outlet Manifolds

The laminar flow in the manifolds is described by the equations in 3D, set up by the Laminar Flow interface.

Microchannels

The 1D flow in the channels is modeled using the Pipe Flow interface, that calculates the pressure drop over a pipe and the continuity equation according to:

$$\nabla p + \rho \mathbf{u} \cdot \nabla \mathbf{u} = -f_D \frac{\rho}{2d_h} \mathbf{u} |\mathbf{u}| \quad (1)$$

$$\nabla \cdot (A \rho \mathbf{u}) = 0$$

Where d_h is the mean hydraulic diameter (m), given by:

$$d_h = \frac{4A}{Z}$$

where A is the pipe cross section area (m^2) available for flow, and Z is the wetted perimeter (m).

The right hand side of [Equation 1](#) describes the pressure drop due to internal viscous shear and contains the Darcy friction factor, f_D . The Pipe Flow interface provides a library of built-in expressions for f_D covering laminar and turbulent flow regimes, as well as Newtonian and non-Newtonian fluids.

BOUNDARY CONDITIONS

Coupling the 3D flow in the manifolds to the 1D flow in the channels is easily done with the multiphysics coupling Pipe Connection.

An fully developed flow boundary condition with average velocity of 5 cm/s is set at the manifold inlet. On the manifold outlets, facing the microchannel inlets, a pipe connection multiphysics feature sets up appropriate conditions automatically.

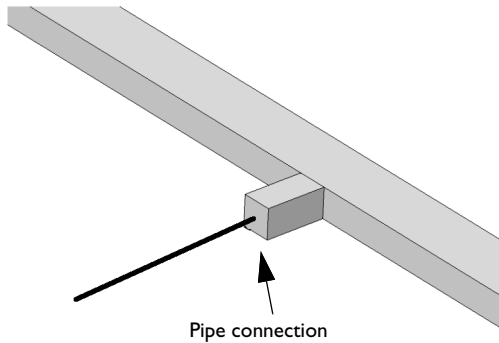

Figure 3: The connection between the pipe segment and the 3D flow domain is easily done with the multiphysics coupling Pipe Connection.

Results and Discussion

Figure 4 shows the pressure distribution in the model. The microchannels contribute to the major part of the pressure drop.

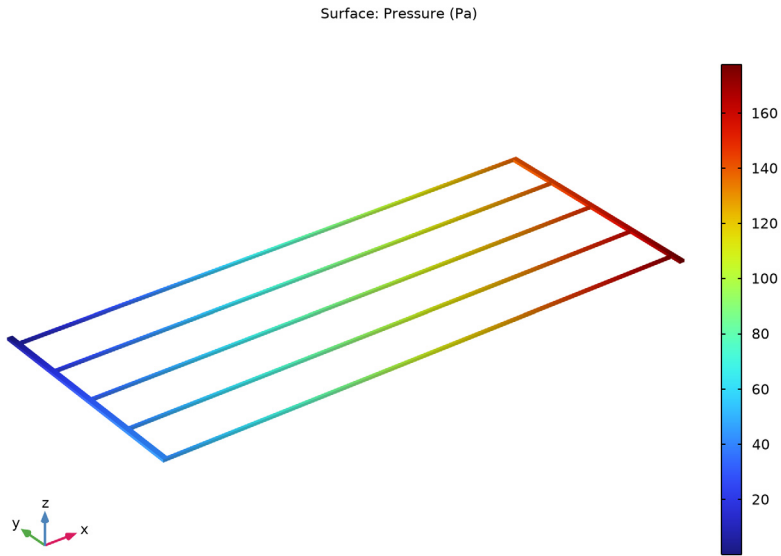

Figure 4: The main pressure drop occurs the microchannels.

Figure 5 shows the velocity in the microchannels. The velocity is lower in the central channels, reducing the heat exchange efficiency in this region. A change in the manifold design would be necessary for a more uniform flow distribution in the plate channels.

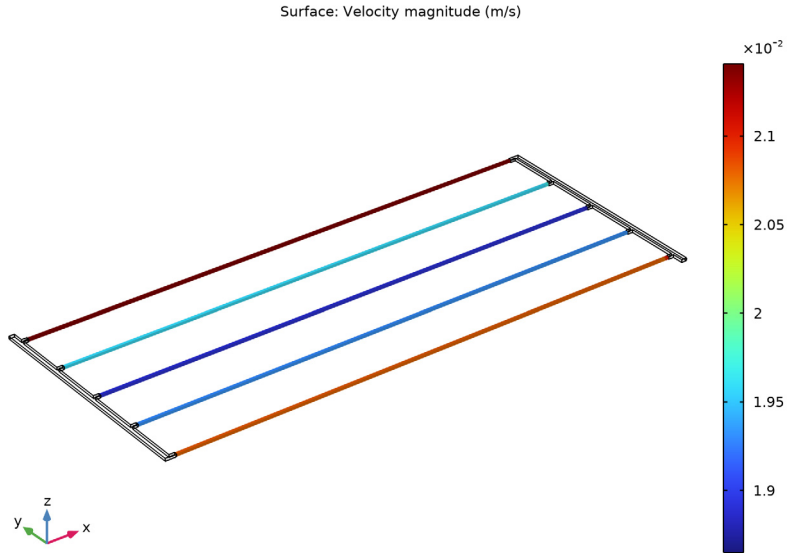



Figure 5: Flow velocity magnitude in the microchannels.

Application Library path: Pipe_Flow_Module/Tutorials/heat_exchanger_plate

Modeling Instructions



From the **File** menu, choose **New**.

NEW

In the **New** window, click  **Model Wizard**.

MODEL WIZARD

- 1 In the **Model Wizard** window, click  **3D**.
- 2 In the **Select Physics** tree, select **Fluid Flow** > **Single-Phase Flow** > **Pipe Flow (pfl)**.
- 3 Click **Add**.
- 4 In the **Select Physics** tree, select **Fluid Flow** > **Single-Phase Flow** > **Laminar Flow (spf)**.

- 5 Click **Add**.
- 6 Click  **Study**.
- 7 In the **Select Study** tree, select **General Studies > Stationary**.
- 8 Click  **Done**.

GEOMETRY I

Insert the prepared geometry sequence from file. You can read the instruction for creating the geometry in the appendix.

- 1 In the **Geometry** toolbar, click **Insert Sequence** and choose **Insert Sequence**.
- 2 Browse to the model's Application Libraries folder and double-click the file `heat_exchanger_plate_geom_sequence.mph`.
- 3 In the **Geometry** toolbar, click  **Build All**.

DEFINITIONS

Add Material

From the **Home** menu, choose **Add Material**.

ADD MATERIAL

- 1 Go to the **Add Material** window.
- 2 In the tree, select **Built-in > Water, liquid**.
- 3 Click the **Add to Component** button in the window toolbar.
- 4 Click the **Add to Component** button in the window toolbar.
- 5 From the **Home** menu, choose **Add Material**.

MATERIALS

Water, liquid 1 (mat2)

- 1 In the **Settings** window for **Material**, locate the **Geometric Entity Selection** section.
- 2 From the **Geometric entity level** list, choose **Edge**.
- 3 From the **Selection** list, choose **Array 1**.

PIPE FLOW (PFL)

- 1 In the **Model Builder** window, expand the **Component 1 (comp1) > Definitions** node, then click **Component 1 (comp1) > Pipe Flow (pfl)**.
- 2 In the **Settings** window for **Pipe Flow**, locate the **Edge Selection** section.

3 From the **Selection** list, choose **Array 1**.

Fluid Properties 1

No settings are needed for the fluid properties because these are retrieved from the material.

Pipe Properties 1

- 1 In the **Model Builder** window, click **Pipe Properties 1**.
- 2 In the **Settings** window for **Pipe Properties**, locate the **Pipe Shape** section.
- 3 From the list, choose **Square**.
- 4 In the w_i text field, type 1 [mm].

LAMINAR FLOW (SPF)

Now set up the Laminar Flow interface. Again, the fluid properties are taken from the material.

- 1 In the **Model Builder** window, under **Component 1 (comp1)** click **Laminar Flow (spf)**.

Inlet 1

- 1 In the **Physics** toolbar, click  **Boundaries** and choose **Inlet**.
- 2 Select Boundary 43 only.
- 3 In the **Settings** window for **Inlet**, locate the **Boundary Condition** section.
- 4 From the list, choose **Fully developed flow**.
- 5 Locate the **Fully Developed Flow** section. In the U_{av} text field, type 5 [cm/s].

Outlet 1

- 1 In the **Physics** toolbar, click  **Boundaries** and choose **Outlet**.
- 2 Select Boundary 5 only.
- 3 In the **Settings** window for **Outlet**, locate the **Pressure Conditions** section.
- 4 Select the **Normal flow** checkbox.

MULTIPHYSICS

Pipe Connection 1 (plc1)

In the **Physics** toolbar, click  **Multiphysics Couplings** and choose **Global > Pipe Connection**.

MESH 1

Now proceed to make some manual adjustments of the physics-controlled mesh.

- 1 In the **Model Builder** window, under **Component 1 (comp1)** click **Mesh 1**.
- 2 In the **Settings** window for **Mesh**, locate the **Physics-Controlled Mesh** section.
- 3 From the **Element size** list, choose **Finer**.
- 4 Right-click **Component 1 (comp1) > Mesh 1** and choose **Edit Physics-Induced Sequence**.

Size 3

- 1 In the **Model Builder** window, under **Component 1 (comp1) > Mesh 1** click **Size 3**.
- 2 In the **Settings** window for **Size**, locate the **Element Size** section.
- 3 Click the **Predefined** button.
- 4 From the **Predefined** list, choose **Normal**.
- 5 Click  **Build All**.

STUDY 1

- 1 In the **Model Builder** window, click **Study 1**.
- 2 In the **Settings** window for **Study**, locate the **Study Settings** section.
- 3 Clear the **Generate default plots** checkbox.
- 4 In the **Study** toolbar, click  **Compute**.

Create the result plots shown in [Figure 4](#) and [Figure 5](#) following these steps:

RESULT TEMPLATES

- 1 In the **Home** toolbar, click  **Result Templates** to open the **Result Templates** window.
- 2 Go to the **Result Templates** window.
- 3 In the tree, select **Study 1/Solution 1 (sol1) > Pipe Flow > Pressure, 3D (pfl)**.
- 4 Click the **Add Result Template** button in the window toolbar.

RESULTS

Surface 1

- 1 In the **Model Builder** window, expand the **Pressure, 3D (pfl)** node, then click **Surface 1**.
- 2 In the **Settings** window for **Surface**, locate the **Expression** section.
- 3 In the **Expression** text field, type $p - 1$ [atm].
- 4 In the **Pressure, 3D (pfl)** toolbar, click  **Plot**.

Surface 2

- 1 In the **Model Builder** window, right-click **Pressure, 3D (pfl)** and choose **Surface**.
- 2 In the **Settings** window for **Surface**, locate the **Data** section.

- 3 From the **Dataset** list, choose **Study 1/Solution 1 (sol1)**.
- 4 Locate the **Expression** section. In the **Expression** text field, type p2.
- 5 Click to expand the **Inherit Style** section. From the **Plot** list, choose **Surface 1**.
- 6 In the **Pressure, 3D (pfl)** toolbar, click  **Plot**.

This plot uses the Pipe dataset that provides a three-dimensional representation of the pipes. You can adjust the orientation of a pipe cross section to improve the plot.

PIPE FLOW (PFL)

Pipe Properties 1

In the **Model Builder** window, under **Component 1 (comp1) > Pipe Flow (pfl)** click **Pipe Properties 1**.

Section Orientation 1

- 1 In the **Physics** toolbar, click  **Attributes** and choose **Section Orientation**.
- 2 In the **Settings** window for **Section Orientation**, locate the **Section Orientation** section.
- 3 From the **Orientation method** list, choose **Orientation vector**.
- 4 Specify the V vector as



0	X
0	Y

STUDY 1

In the **Study** toolbar, click  **Update Solution**.

RESULTS

Surface 1

- 1 In the **Model Builder** window, under **Results > Pressure, 3D (pfl)** click **Surface 1**.
- 2 In the **Settings** window for **Surface**, click to expand the **Title** section.
- 3 From the **Title type** list, choose **None**.
- 4 In the **Pressure, 3D (pfl)** toolbar, click  **Plot**.
- 5 Click the  **Zoom Extents** button in the **Graphics** toolbar.

Velocity, 3D

- 1 In the **Results** toolbar, click  **3D Plot Group**.
- 2 In the **Settings** window for **3D Plot Group**, type Velocity, 3D in the **Label** text field.

Surface 1

- 1 Right-click **Velocity, 3D** and choose **Surface**.
- 2 In the **Settings** window for **Surface**, locate the **Data** section.
- 3 From the **Dataset** list, choose **Pipe**.
- 4 Click **Replace Expression** in the upper-right corner of the **Expression** section. From the menu, choose **Component 1 (comp1) > Pipe Flow > pfl.U - Velocity magnitude - m/s**.
- 5 In the **Velocity, 3D** toolbar, click  **Plot**.

CREATING THE GEOMETRY

The previously inserted geometry can be created from scratch like this:

ADD COMPONENT

In the **Home** toolbar, click  **Add Component** and choose **3D**.

GLOBAL DEFINITIONS

Parameters 1

- 1 In the **Model Builder** window, under **Global Definitions** click **Parameters 1**.
- 2 In the **Settings** window for **Parameters**, locate the **Parameters** section.
- 3 In the table, enter the following settings:

Name	Expression	Value	Description
Lp	190[mm]	0.19 m	Pipe length

GEOMETRY 1

- 1 In the **Model Builder** window, under **Component 1 (comp1)** click **Geometry 1**.
- 2 In the **Settings** window for **Geometry**, locate the **Units** section.
- 3 From the **Length unit** list, choose **mm**.



Work Plane 1 (wp1)

- 1 In the **Geometry** toolbar, click  **Work Plane**.
- 2 In the **Settings** window for **Work Plane**, locate the **Plane Definition** section.
- 3 In the **z-coordinate** text field, type 0.5.

Work Plane 1 (wp1) > Plane Geometry

In the **Model Builder** window, click **Plane Geometry**.

Work Plane 1 (wp1) > Line Segment 1 (ls1)

- 1 In the **Work Plane** toolbar, click  **More Primitives** and choose **Line Segment**.
- 2 In the **Settings** window for **Line Segment**, locate the **Starting Point** section.
- 3 From the **Specify** list, choose **Coordinates**.
- 4 Locate the **Endpoint** section. From the **Specify** list, choose **Coordinates**.
- 5 Locate the **Starting Point** section. In the **yw** text field, type 0.5.
- 6 Locate the **Endpoint** section. In the **xw** text field, type Lp.
- 7 In the **yw** text field, type 0.5.
- 8 Click  **Build Selected**.
- 9 Click the  **Zoom Extents** button in the **Graphics** toolbar.



Create an array of the curve and enable Create selections to facilitate selection later on in the physics settings.

Array 1 (arr1)

- 1 In the **Model Builder** window, right-click **Geometry 1** and choose **Transforms > Array**.
- 2 Select the object **wp1** only.
- 3 In the **Settings** window for **Array**, locate the **Size** section.
- 4 In the **y size** text field, type 5.
- 5 Locate the **Displacement** section. In the **y** text field, type 20.
- 6 Locate the **Selections of Resulting Entities** section. Select the **Resulting objects selection** checkbox.
- 7 From the **Show in physics** list, choose **Edge selection**.

Create the inlet and outlet manifolds using blocks.

Block 1 (blk1)

- 1 In the **Geometry** toolbar, click  **Block**.
- 2 In the **Settings** window for **Block**, locate the **Size and Shape** section.
- 3 In the **Width** text field, type 2.
- 4 Locate the **Position** section. In the **x** text field, type -2.
- 5 Click  **Build Selected**.
- 6 Click the  **Zoom Extents** button in the **Graphics** toolbar.

Block 2 (blk2)

- 1 Right-click **Block 1 (blk1)** and choose **Duplicate**.
- 2 In the **Settings** window for **Block**, locate the **Position** section.

3 In the **x** text field, type Lp.

4 Click  **Build Selected**.

Array 2 (arr2)

1 In the **Geometry** toolbar, click  **Transforms** and choose **Array**.

2 Select the objects **blk1** and **blk2** only.

3 In the **Settings** window for **Array**, locate the **Size** section.

4 In the **y size** text field, type 5.

5 Locate the **Displacement** section. In the **y** text field, type 20.

6 Click  **Build Selected**.

Block 3 (blk3)

1 In the **Model Builder** window, under **Component 1 (comp1) > Geometry 1** right-click **Block 2 (blk2)** and choose **Duplicate**.

2 In the **Settings** window for **Block**, locate the **Size and Shape** section.

3 In the **Depth** text field, type 85.

4 Locate the **Position** section. In the **x** text field, type -4.

5 Click  **Build Selected**.

Block 4 (blk4)

1 Right-click **Block 3 (blk3)** and choose **Duplicate**.

2 In the **Settings** window for **Block**, locate the **Position** section.

3 In the **x** text field, type Lp+2.

4 In the **y** text field, type -4.

5 Click  **Build Selected**.

Form Composite Domains 1 (cmd1)

1 In the **Geometry** toolbar, click  **Virtual Operations** and choose **Form Composite Domains**.

2 On the object **fin**, select Domains 1–12 only.

3 In the **Geometry** toolbar, click  **Build All**.