



Model created in COMSOL Multiphysics 6.4

# Shape Optimization of a Wrench

## *Introduction*

---

Shape optimization can be used to alter the geometry of an existing product to improve its performance. This can be achieved using the Deformed Geometry interface, but one has to decide which shape deformations to allow. It is important to impose some restriction to preserve the mesh quality during the optimization. One approach is to use a Helmholtz filter to introduce a length scale, which (in combination with a Maximum displacement parameter) limits the slope of the shape variations. This type of regularized shape optimization can be set up using equations based modeling, but it is also built into the **Free Shape Boundary** feature. This model applies the feature to a CAD representation of a wrench, but the initial geometry can also come from topology optimization as shown in the model [Shape Optimization of an MBB Beam](#).

## *Model Definition*

---

Shape optimization is often subject to constraints on the geometry deformation, and in this model it does not make sense to deform the parts of the wrench that are designed to grab the bolt head. These parts are, however, associated with many boundaries, so the model uses two cylinder selections to define the fixed boundaries ([Figure 1](#)).

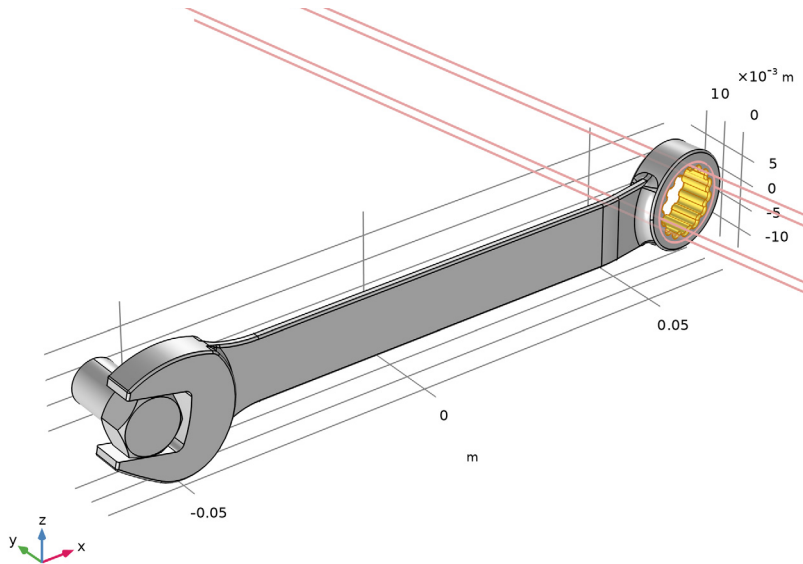

Figure 1: The plots shows one of the cylinder selections used to define the fixed boundaries. The selections are based on parameters that can be imported from a text file, but they can also be computed using the Measure functionality.

The wrench is made of structural steel and the objective is to maximize its stiffness without using more material. An initial study is performed to determine characteristic values for the total elastic strain energy and the volume. These values are used for scaling the optimization problem, which is an important step for constrained optimization problems.

### Results and Discussion

Visualizing the shape deformation can require custom plots or tweaking of parameters for the default plot, but in this case the default plot shown in Figure 2 illustrates that

- Material has been removed from the head and handle of the wrench.
- The kink near the handle has been straightened out.
- The middle part of the wrench is wider in the z direction.
- The connection to the head of the wrench is thicker in the y direction.

The two last points are a bit difficult to see, because the arrows are inside the geometry, but the *relative normal boundary displacement* is the displacement in the normal

direction relative to the maximum possible displacement in the normal direction, so when this is significantly larger than zero and there are no arrows, it means that the arrows are inside the geometry. They can be seen by enabling transparency.

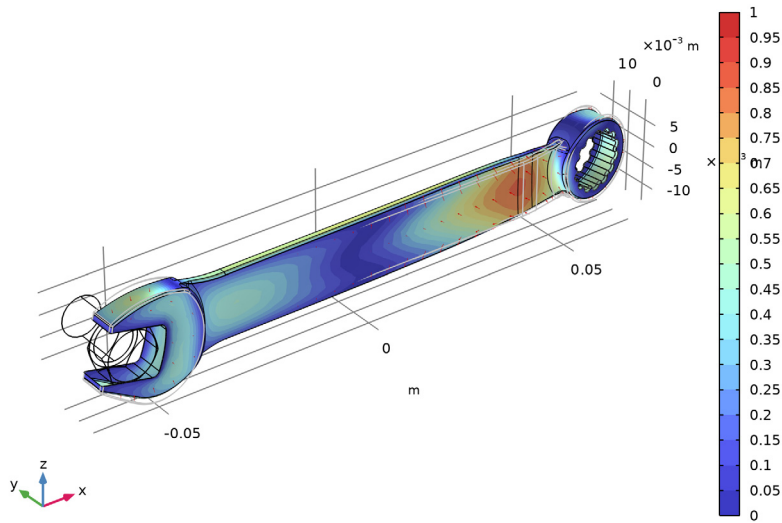

*Figure 2: The default shape optimization plot shows the edges of the old geometry in gray together with a surface plot of the relative normal boundary displacement in colors. The actual displacement is shown with red arrows, but they are plotted inside the geometry wherever this is expanded.*

Alternatively the initial and optimized volumes can be plotted on top of each other, but this plot only makes sense with transparency enabled. This plot is shown in [Figure 3](#). This

kind of plot can suffer from  $z$ -fighting artifacts on **Symmetry/Roller** boundaries, but this feature is not used in the model.

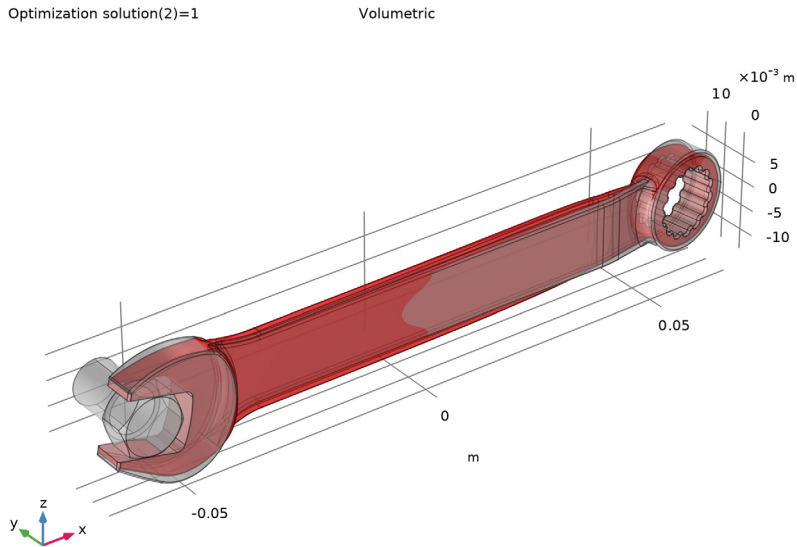

*Figure 3: The shape of the wrench is optimized by removing material from the head and the handle. Furthermore, the middle part is thicker in the  $z$  direction and the kink near the handle has been straightened out.*

---

### *Notes About the COMSOL Implementation*

---

This model combines the Shape Optimization interface with the Solid Mechanics interfaces. First, you setup and solve the for the structural problem for the initial geometry. The objective and constraint can be defined automatically by using the study wizard, but you have to define the controls using the shape optimization features available on the component. Keep in mind that allowing a large Maximum displacement will result in NaN/Inf solver errors due to inverted elements.

---

**Application Library path:** Optimization\_Module/Shape\_Optimization/  
wrench\_shape\_optimization

---

## Modeling Instructions



---

From the **File** menu, choose **New**.

### NEW

In the **New** window, click  **Model Wizard**.

### MODEL WIZARD

- 1 In the **Model Wizard** window, click .
- 2 In the **Select Physics** tree, select **Structural Mechanics > Solid Mechanics (solid)**.
- 3 Click **Add**.
- 4 Click  **Study**.
- 5 In the **Select Study** tree, select **Preset Studies for Selected Physics Interfaces > Optimization > Shape Optimization, Stationary**.
- 6 Click  **Done**.

### GLOBAL DEFINITIONS

#### Geometrical Parameters



- 1 In the **Home** toolbar, click  **Parameters** and choose **Add > Parameters**.
- 2 In the **Settings** window for **Parameters**, type Geometrical Parameters in the **Label** text field.  
  
Input the geometric parameters manually or load them from wrench\_shape\_optimization\_parameters.txt. The parameters can be computed using the **Measure** geometry feature.
- 3 Locate the **Parameters** section. In the table, enter the following settings:

Name	Expression	Value	Description
xbolt	-0.05766114111[m]	-0.057661 m	Bolt x position
ybolt	0.002375[m]	0.002375 m	Bolt y position
zbolt	-0.00124108777[m]	-0.0012411 m	Bolt z position
dbolt	0.01283160973[m]	0.012832 m	Bolt diameter
dhole	0.01267099011[m]	0.012671 m	Hole diameter

Name	Expression	Value	Description
xhole	0.05803823603[m]	0.058038 m	Hole x position
yhole	-3.745973518E-5[m]	-3.746E-5 m	Hole y position
zhole	-2.161723792E-4[m]	-2.1617E-4 m	Hole z position
xholeaxis	0.001098722599[m]	0.0010987 m	Hole axis x-component
yholeaxis	-0.006231165503[m]	-0.0062312 m	Hole axis y-component
zholeaxis	0[m]	0 m	Hole axis z-component

## GEOMETRY I



### Import I (impl)

- 1 In the **Geometry** toolbar, click  **Import**.
- 2 In the **Settings** window for **Import**, locate the **Source** section.
- 3 Click  **Browse**.
- 4 Browse to the model's Application Libraries folder and double-click the file wrench.mphbin.
- 5 Click  **null**.
- 6 Locate the **Selections of Resulting Entities** section. Select the **Resulting objects selection** checkbox.

### Nut Faces

- 1 In the **Geometry** toolbar, click  **Selections** and choose **Cylinder Selection**.
- 2 In the **Settings** window for **Cylinder Selection**, type Nut Faces in the **Label** text field.
- 3 Locate the **Geometric Entity Level** section. From the **Level** list, choose **Boundary**.
- 4 Locate the **Size and Shape** section. In the **Outer radius** text field, type  $dbolt*0.7$ .
- 5 Locate the **Axis** section. From the **Axis type** list, choose **y-axis**.
- 6 Locate the **Position** section. In the **x** text field, type  $xbolt$ .
- 7 In the **y** text field, type  $ybolt$ .
- 8 In the **z** text field, type  $zbolt$ .
- 9 Locate the **Output Entities** section. From the **Include entity if** list, choose **Entity inside cylinder**.

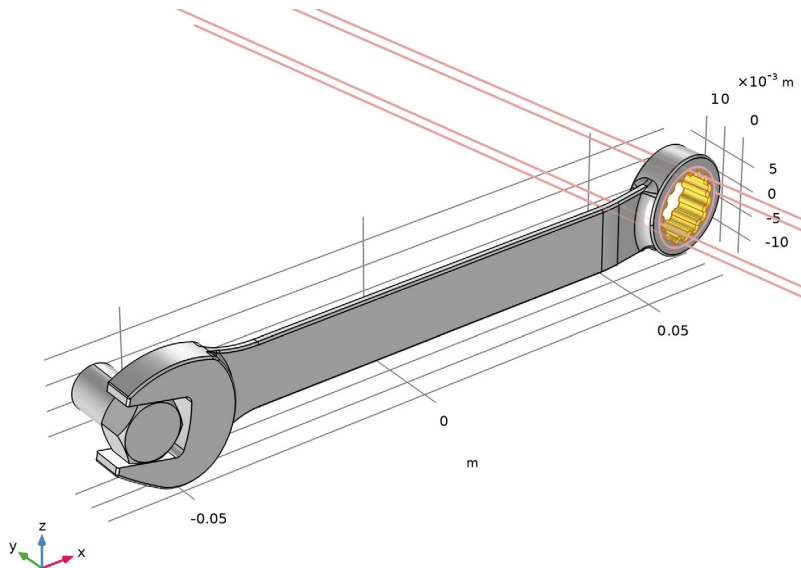

### Handle Hole Faces

- 1 In the **Geometry** toolbar, click  **Selections** and choose **Cylinder Selection**.
- 2 In the **Settings** window for **Cylinder Selection**, type Handle Hole Faces in the **Label** text field.
- 3 Locate the **Geometric Entity Level** section. From the **Level** list, choose **Boundary**.
- 4 Locate the **Size and Shape** section. In the **Outer radius** text field, type  $\text{dhole} * 0.6$ .
- 5 Locate the **Position** section. In the **x** text field, type  $\text{xhole}$ .
- 6 In the **y** text field, type  $\text{yhole}$ .
- 7 In the **z** text field, type  $\text{zhole}$ .
- 8 Locate the **Axis** section. From the **Axis type** list, choose **Cartesian**.
- 9 In the **x** text field, type  $\text{xholeaxis}$ .
- 10 In the **y** text field, type  $\text{yholeaxis}$ .
- 11 In the **z** text field, type  $\text{zholeaxis}$ .
- 12 Locate the **Output Entities** section. From the **Include entity if** list, choose **Entity inside cylinder**.
- 13 Click  **Build Selected**.





The selection should now look like that in [Figure 1](#).



### *Interior Faces*

- 1 In the **Geometry** toolbar, click  **Selections** and choose **Adjacent Selection**.
- 2 In the **Settings** window for **Adjacent Selection**, type Interior Faces in the **Label** text field.
- 3 Locate the **Input Entities** section. Click  **Add**.
- 4 In the **Add** dialog, select **Import I** in the **Input selections** list.
- 5 Click **OK**.



### *Optimized Faces*

- 1 In the **Geometry** toolbar, click  **Selections** and choose **Complement Selection**.
- 2 In the **Settings** window for **Complement Selection**, type Optimized Faces in the **Label** text field.
- 3 Locate the **Geometric Entity Level** section. From the **Level** list, choose **Boundary**.
- 4 Locate the **Input Entities** section. Click  **Add**.
- 5 In the **Add** dialog, in the **Selections to invert** list, choose **Nut Faces** and **Handle Hole Faces**.
- 6 Click **OK**.



### *Boundary load*

- 1 In the **Geometry** toolbar, click  **Selections** and choose **Explicit Selection**.
- 2 In the **Settings** window for **Explicit Selection**, type Boundary load in the **Label** text field.
- 3 Locate the **Entities to Select** section. From the **Geometric entity level** list, choose **Boundary**.
- 4 On the object **impl**, select Boundary 111 only.
- 5 Click  **Build Selected**.

### *Fixed constraint*

- 1 In the **Geometry** toolbar, click  **Selections** and choose **Explicit Selection**.
- 2 In the **Settings** window for **Explicit Selection**, type Fixed constraint in the **Label** text field.
- 3 Locate the **Entities to Select** section. From the **Geometric entity level** list, choose **Boundary**.
- 4 Click the  **Wireframe Rendering** button in the **Graphics** toolbar.
- 5 On the object **impl**, select Boundary 35 only.
- 6 Click the  **Wireframe Rendering** button in the **Graphics** toolbar to turn off wireframe rendering.

## ADD MATERIAL

- 1 In the **Materials** toolbar, click  **Add Material** to open the **Add Material** window.
- 2 Go to the **Add Material** window.
- 3 In the tree, select **Built-in > Structural steel**.
- 4 Click the **Add to Component** button in the window toolbar.
- 5 In the **Geometry Cleanup** dialog that opens, click **Clean up Automatically** to automatically clean up the geometry by removing some narrow face regions.
- 6 In the **Materials** toolbar, click  **Add Material** to close the **Add Material** window.

## SOLID MECHANICS (SOLID)

### *Fixed Constraint I*

- 1 In the **Physics** toolbar, click  **Boundaries** and choose **Fixed Constraint**.
- 2 In the **Settings** window for **Fixed Constraint**, locate the **Boundary Selection** section.
- 3 From the **Selection** list, choose **Fixed constraint**.

### *Boundary Load I*

- 1 In the **Physics** toolbar, click  **Boundaries** and choose **Boundary Load**.
- 2 In the **Settings** window for **Boundary Load**, locate the **Boundary Selection** section.
- 3 From the **Selection** list, choose **Boundary load**.
- 4 Locate the **Force** section. From the **Load type** list, choose **Total force**.
- 5 Specify the  $\mathbf{F}_{\text{tot}}$  vector as

0	x
0	y
-F	z

## GLOBAL DEFINITIONS

### *Parameters I*

- 1 In the **Model Builder** window, under **Global Definitions** click **Parameters I**.
- 2 In the **Settings** window for **Parameters**, locate the **Parameters** section.
- 3 In the table, enter the following settings:

Name	Expression	Value	Description
F	150[N]	150 N	Applied force
maxD	2[mm]	0.002 m	Maximum displacement

## MESH 1

- 1 In the **Model Builder** window, under **Component 1 (comp1)** click **Mesh 1**.
- 2 In the **Settings** window for **Mesh**, locate the **Physics-Controlled Mesh** section.
- 3 From the **Element size** list, choose **Coarser**.

## SHAPE OPTIMIZATION

### *Free Shape Domain 1*

Change the selection of the **Free Shape Domain**, so that the shape of the bolt is not changed.

- 1 In the **Model Builder** window, under **Component 1 (comp1)** > **Shape Optimization** click **Free Shape Domain 1**.
- 2 Select Domain 1 only.

## DEFINITIONS

Add a **Free Shape Boundary** feature to allow the shape of the wrench to change.

## SHAPE OPTIMIZATION

### *Free Shape Boundary 1*

- 1 In the **Shape Optimization** toolbar, click  **Free Shape Boundary**.
- 2 In the **Settings** window for **Free Shape Boundary**, locate the **Boundary Selection** section.
- 3 From the **Selection** list, choose **Optimized Faces**.
- 4 Locate the **Control Variable Settings** section. In the text field, type maxD.

## STUDY 1

### *Shape Optimization*

- 1 In the **Model Builder** window, under **Study 1** click **Shape Optimization**.
- 2 In the **Settings** window for **Shape Optimization**, locate the **Optimization Solver** section.
- 3 In the **Move limits** text field, type 0.2.
- 4 In the **Maximum number of iterations** text field, type 20.
- 5 In the **Model Builder** window, click **Study 1**.
- 6 In the **Settings** window for **Study**, type Shape Optimization in the **Label** text field.
- 7 In the **Study** toolbar, click  **Get Initial Value**.  
The deformed shape can be exported as an STL file.
- 8 In the **Model Builder** window, click **Shape Optimization**.

- 9 In the **Settings** window for **Shape Optimization**, click to expand the **Output** section.
- 10 From the **Keep solutions** list, choose **First and last**.
- 11 Select the **Plot** checkbox.
- 12 From the **Plot group** list, choose **Shape Optimization**.
- 13 In the **Study** toolbar, click  **Compute**.

## RESULTS

- 1 In the **Model Builder** window, under **Results** click **Shape Optimization**.
- 2 In the **Shape Optimization** toolbar, click  **Plot**.

### *Mesh 1*

- 1 In the **Model Builder** window, expand the **Results > Datasets** node.
- 2 Right-click **Results > Datasets > Shape Optimization/Solution 1 (sol1)** and choose **Add Mesh to Export**.
- 3 In the **Settings** window for **Mesh**, locate the **Output** section.
- 4 From the **File type** list, choose **STL binary file (\*.stl; \*.STL)**.
- 5 In the **Filename** text field, type `wrench_shape_optimization.stl`.

Plot the initial and optimized volumes on top of each other to illustrate the shape change in a clear way (assuming transparency is enabled). This plot can give rise to z-fighting artifact on **Symmetry/Roller** boundaries, but this model does not use that feature.

### *Volumetric*

- 1 In the **Results** toolbar, click  **3D Plot Group**.
- 2 In the **Settings** window for **3D Plot Group**, click to expand the **Title** section.
- 3 From the **Title type** list, choose **Label**.
- 4 In the **Label** text field, type `Volumetric`.

### *Optimized Design*



- 1 Right-click **Volumetric** and choose **Volume**.
- 2 In the **Settings** window for **Volume**, type `Optimized Design` in the **Label** text field.
- 3 Locate the **Coloring and Style** section. From the **Coloring** list, choose **Uniform**.

### *Initial Design*

- 1 Right-click **Optimized Design** and choose **Duplicate**.
- 2 In the **Settings** window for **Volume**, type `Initial Design` in the **Label** text field.

- 3 Locate the **Data** section. From the **Dataset** list, choose **Shape Optimization/Solution I (solI)**.
- 4 From the **Optimization solution** list, choose **0**.
- 5 Locate the **Coloring and Style** section. From the **Color** list, choose **Gray**.

#### *Line 1*

- 1 In the **Model Builder** window, right-click **Volumetric** and choose **Line**.
- 2 In the **Settings** window for **Line**, locate the **Data** section.
- 3 From the **Dataset** list, choose **Shape Optimization/Solution I (solI)**.
- 4 From the **Optimization solution** list, choose **0**.
- 5 Locate the **Expression** section. In the **Expression** text field, type 1.
- 6 Locate the **Coloring and Style** section. From the **Coloring** list, choose **Uniform**.
- 7 From the **Color** list, choose **From theme**.
- 8 Click the  **Transparency** button in the **Graphics** toolbar.
- 9 In the **Volumetric** toolbar, click  **Plot**.

#### *Stress - Optimized Design*

- 1 In the **Model Builder** window, under **Results** click **Stress (solid)**.
- 2 In the **Settings** window for **3D Plot Group**, type **Stress - Optimized Design** in the **Label** text field.