



Model created in COMSOL Multiphysics 6.4

# Topology Optimization of a District Heating Network

## *Introduction*

---

Power plants utilizing cogeneration can reach high efficiencies in winter time, but they rely on district heating networks. The design of such networks has previously been limited to inaccurate linear models or nonlinear models of small networks. Recent research has demonstrated gradient-based optimization for designing large networks using nonlinear models (Ref. 2). This model reproduces this research using the Pipe Flow Module and Optimization Module of COMSOL Multiphysics. Power plants for electricity generation often convert less than half the input energy to electrical energy. It is possible to increase the efficiency by capturing the heat generated in the process. The heat can be used for residential heating in urban environments, but to realize this one has to construct a network of pipes for distributing the heat. The technology can allow efficiencies up to 80% in winter time Ref. 1.

## *Model Definition*

---

The model considers identical consumers, continuous pipe diameters, and a simple models for the radiators and network heat loss. This means that the resulting network topology is likely to be good, but to be able to trust the quantitative values for the pipe diameters it

might be necessary to use more advanced expressions and techniques as has been done in [Ref. 2](#).

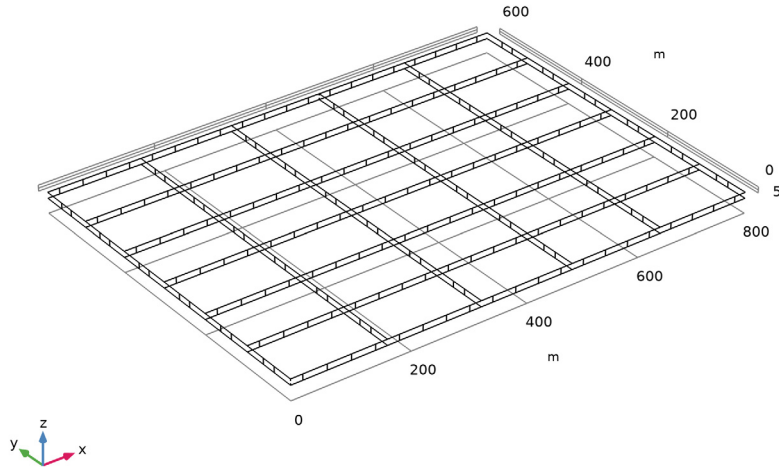

*Figure 1: The initial geometry.*

The initial geometry for this model is shown in [Figure 1](#).

The optimization problem consists of controls, constraints, and objectives.

## **CONTROLS**

District heating network are generally aligned with the road infrastructure, so the question of how the network should be designed can be reduced to a question of which roads should have pipes and how large should the pipes be. The consumers are generally (financially) punished for returning the heated water too hot, because this constitutes a waste of pumping energy. Consumers thus have an incentive to decrease the flow speed over the heat exchanger that connects the heating network to their heating system of their property. This can lead low flow rates in the system, which can cause low temperatures for consumers far from the producer due to heat lost from the network to the earth. To prevent this issue, the heating network is equipped with bypass valves in the end of the network so that an adequate flow rate can be ensured. Because the endpoints of the network are not known, treat each producer as a bypass valve and optimize the diameter of this. Also, optimize the coupling constant to the network, which corresponds to a

setting for the consumer heating system. Finally, allow the driving pressure over the network to be optimized.

### CONSTRAINTS

In order for the network to be valid it has to be able to distribute sufficient heat to all consumers, but a large network will have many consumers leading to many constraints, which can be numerically problematic. A popular solution to this problem is to use a constraint aggregation technique, so that a large number of linear constraints is converted to a single nonlinear constraint, that is

$$C = \frac{\log \left( \sum_{i=1}^{N_{\text{consumers}}} \exp(\beta [P/P_{\text{target}} - 1]^2) \right)}{\beta N_{\text{consumers}}} \leq \varepsilon$$

The violation of local constraints will decrease with larger values of  $\beta$ , but the large values will also cause numerical problems, so in practice a compromise has to be found.

### OBJECTIVE

The primary cost of establishing the network is related to the total length of trenches that have to be dug, but larger pipes also cost more than smaller pipes, so the cost can be approximated as

$$\text{EUR}_{\text{pipes}} = \int_{\text{roads}} (aD - b) dl$$

where  $D$  is the pipe diameter and  $b$  is the cost of digging a trench. By itself, this would lead to a network with very small pipes and a large pressure drop requiring an expensive pump. This can be avoided by adding a term related to the pumping power, so that the total objective function becomes

$$\text{EUR}_{\text{total}} = \text{EUR}_{\text{pipes}} + P_{\text{pump}} 100[\text{EUR}/\text{W}]$$

The constant relating the pumping power to the objective function depends on several factors, such as the maintenance cost of the network, the price of electricity, and the cost of capital.

## Results and Discussion

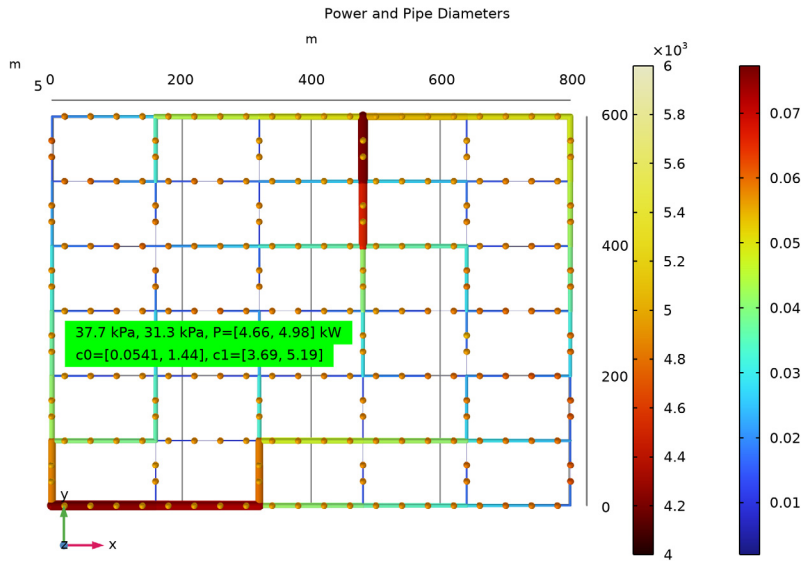
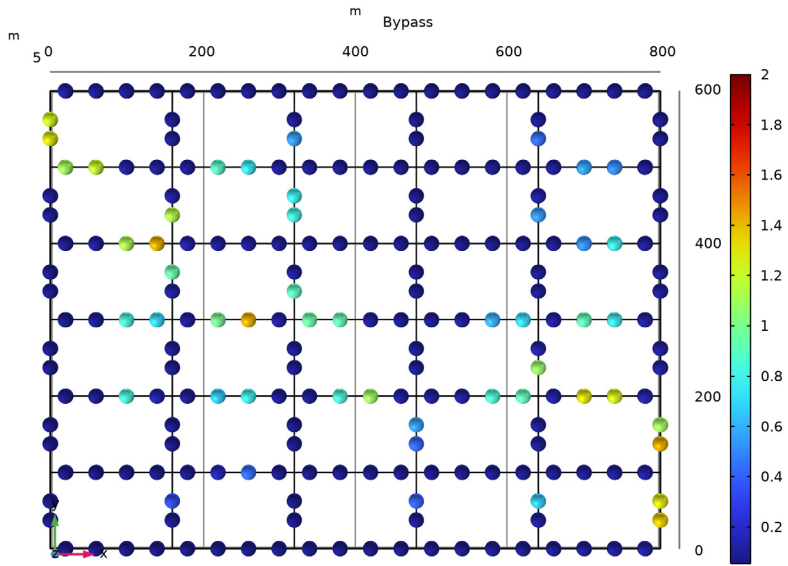

Figure 2: The network topology is shown with the consumer heating powers. The minimum power is 4.7 kW, so none of the consumers are freezing.

Each consumers requires 5 kW of heating power. Two heat producers with in flow temperatures of 65 and 70°C are considered (top and lower right, respectively). The model starts out by optimizing the bypass and radiator controls, with the constraint,  $C$ , as the objective function. The result of this is used as initial guess, when minimizing  $EUR_{total}$ .

Figure 2 shows the optimized pipe diameters together with the heating power for each consumer. The network design branches into smaller and smaller pipes as one would

expect. In this case, consider a situation, where there are consumers almost everywhere, and this makes it difficult to reduce  $EUR_{pipes}$ .



*Figure 3: The bypass controls are primarily open in the end of the network far from the producers.*

Figure 3 shows the values of the bypass controls. As expected larger values appear in the very end of the network. Finally, Figure 4 illustrates that the consumers belonging to the

network with a 65°C inlet temperature need slightly better radiators, particularly far from the producer.

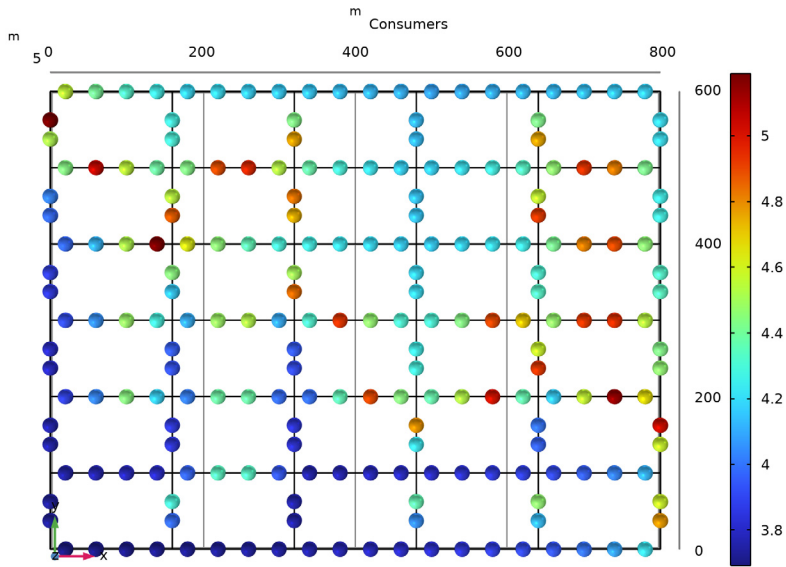

Figure 4: The consumer radiator controls are slightly larger in the network belonging to the upper producer.

## References

1. [www.energy.gov/fecm/how-gas-turbine-power-plants-work](http://www.energy.gov/fecm/how-gas-turbine-power-plants-work)
2. M. Blommaert, Y. Wack, and M. Baelmans, “An adjoint optimization approach for the topological design of large-scale district heating networks based on nonlinear models,” *Applied Energy*, vol. 280, p. 116025, 2020.

## Notes About the COMSOL Implementation

The original MMA optimization solver (which is not globally convergent) is used to avoid premature convergence. A PDE with a Helmholtz filter is used to average the power over each consumer.

---

**Application Library path:** Optimization\_Module/Topology\_Optimization/  
district\_heating\_optimization

---

### *Modeling Instructions*

---



From the **File** menu, choose **New**.

#### **NEW**

In the **New** window, click  **Model Wizard**.

#### **MODEL WIZARD**



- 1 In the **Model Wizard** window, click  **3D**.
- 2 In the **Select Physics** tree, select **Fluid Flow > Nonisothermal Flow > Nonisothermal Pipe Flow (nipfl)**.
- 3 Click **Add**.
- 4 In the **Select Physics** tree, select **Mathematics > PDE Interfaces > Lower Dimensions > Coefficient Form Edge PDE (ce)**.
- 5 Click **Add**.
- 6 In the **Field name (I)** text field, type P.
- 7 In the **Dependent variables (I)** table, enter the following settings:  

|   |
|---|
| P |
|---|
- 8 Click  **Select Dependent Variable Quantity**.
- 9 In the **Physical Quantity** dialog, type power in the text field.
- 10 In the tree, select **General > Power (W)**.
- 11 Click **OK**.
- 12 In the **Model Wizard** window, click  **Select Source Term Quantity**.
- 13 In the **Physical Quantity** dialog, type power in the text field.
- 14 In the tree, select **General > Power (W)**.
- 15 Click **OK**.
- 16 In the **Model Wizard** window, click  **Study**.
- 17 In the **Select Study** tree, select **General Studies > Stationary**.

18 Click  **Done**.

## GEOMETRY I

Create the geometry. To simplify this step, insert a prepared geometry sequence.

- 1 In the **Geometry** toolbar, click **Insert Sequence** and choose **Insert Sequence**.
- 2 Browse to the model's Application Libraries folder and double-click the file `district_heating_optimization_geom_sequence.mph`.
- 3 In the **Geometry** toolbar, click  **Build All**.
- 4 Click the  **Zoom Extents** button in the **Graphics** toolbar.
- 5 In the **Model Builder** window, under **Component I (comp1)** click **Geometry I**.

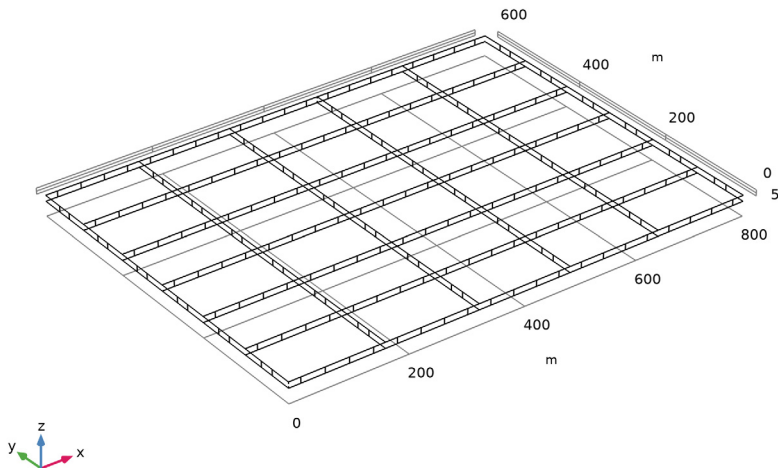

The geometry should now look like that in [Figure 1](#). Note that the inserted geometry is parameterized and that the parameters used are automatically added to the list of global parameters in the model.

- 6 In the **Model Builder** window, collapse the **Geometry I** node.



## GLOBAL DEFINITIONS

### *Geometrical Parameters*



- 1 In the **Model Builder** window, under **Global Definitions** click **Parameters I**.

- 2 In the **Settings** window for **Parameters**, type Geometrical Parameters in the **Label** text field.

#### *Model Parameters*

- 1 In the **Home** toolbar, click  **Parameters** and choose **Add > Parameters**.
- 2 In the **Settings** window for **Parameters**, type Model Parameters in the **Label** text field.
- 3 Locate the **Parameters** section. Click  **Load from File**.
- 4 Browse to the model's Application Libraries folder and double-click the file `district_heating_optimization_parameters.txt`.

#### **ADD MATERIAL**

- 1 In the **Materials** toolbar, click  **Add Material** to open the **Add Material** window.
- 2 Go to the **Add Material** window.
- 3 In the tree, select **Built-in > Water, liquid**.
- 4 Click the **Add to Component** button in the window toolbar.
- 5 In the **Materials** toolbar, click  **Add Material** to close the **Add Material** window.

#### **DEFINITIONS**

##### *Pipes*

- 1 In the **Definitions** toolbar, click  **Control Variables** and choose **Control Variable Field**.
- 2 In the **Settings** window for **Control Variable Field**, type Pipes in the **Label** text field.
- 3 In the **Name** text field, type `pipeControl`.
- 4 Locate the **Geometric Entity Selection** section. From the **Geometric entity level** list, choose **Edge**.
- 5 From the **Selection** list, choose **Hot Flow**.
- 6 Locate the **Discretization** section. From the **Shape function type** list, choose **Discontinuous Lagrange**.
- 7 From the **Element order** list, choose **Constant**.
- 8 Locate the **Bounds** section. Select the **Use bounds** checkbox.
- 9 In the **Lower bound** text field, type  $\log(0.01)$ .
- 10 In the **Upper bound** text field, type  $\log(2)$ .

##### *Bypass*

- 1 In the **Definitions** toolbar, click  **Control Variables** and choose **Control Variable Field**.
- 2 In the **Settings** window for **Control Variable Field**, type Bypass in the **Label** text field.

- 3 In the **Name** text field, type **bypass**.
- 4 Locate the **Geometric Entity Selection** section. From the **Geometric entity level** list, choose **Point**.
- 5 From the **Selection** list, choose **Consumer Hot Points**.
- 6 Locate the **Discretization** section. From the **Shape function type** list, choose **Discontinuous Lagrange**.
- 7 From the **Element order** list, choose **Constant**.
- 8 Locate the **Bounds** section. Select the **Use bounds** checkbox.
- 9 In the **Lower bound** text field, type  $\log(0.01)$ .
- 10 In the **Upper bound** text field, type  $\log(10)$ .

#### *Consumers*

- 1 Right-click **Bypass** and choose **Duplicate**.
- 2 In the **Settings** window for **Control Variable Field**, type **Consumers** in the **Label** text field.
- 3 In the **Name** text field, type **consumers**.
- 4 Locate the **Bounds** section. In the **Lower bound** text field, type  $\log(0.1)$ .

#### *All Pipes*

- 1 In the **Definitions** toolbar, click  **Nonlocal Couplings** and choose **Integration**.
- 2 In the **Settings** window for **Integration**, type **All Pipes** in the **Label** text field.
- 3 In the **Operator name** text field, type **intopAll**.
- 4 Locate the **Source Selection** section. From the **Geometric entity level** list, choose **Edge**.
- 5 From the **Selection** list, choose **All edges**.

#### *Hot Pipes*

- 1 Right-click **All Pipes** and choose **Duplicate**.
- 2 In the **Settings** window for **Integration**, type **Hot Pipes** in the **Label** text field.
- 3 In the **Operator name** text field, type **intopHot**.
- 4 Locate the **Source Selection** section. From the **Selection** list, choose **Hot Flow**.

#### *Consumers*

- 1 Right-click **Hot Pipes** and choose **Duplicate**.
- 2 In the **Settings** window for **Integration**, type **Consumers** in the **Label** text field.
- 3 In the **Operator name** text field, type **intopConsumers**.
- 4 Locate the **Source Selection** section. From the **Selection** list, choose **Consumers**.

#### *Inlet 1*

- 1 Right-click **Consumers** and choose **Duplicate**.
- 2 In the **Settings** window for **Integration**, type Inlet 1 in the **Label** text field.
- 3 In the **Operator name** text field, type intopInlet1.
- 4 Locate the **Source Selection** section. From the **Geometric entity level** list, choose **Point**.
- 5 From the **Selection** list, choose **Inlet 1**.

#### *Outlet 1*

- 1 Right-click **Inlet 1** and choose **Duplicate**.
- 2 In the **Settings** window for **Integration**, type Outlet 1 in the **Label** text field.
- 3 In the **Operator name** text field, type intopOutlet1.
- 4 Locate the **Source Selection** section. From the **Selection** list, choose **Outlet 1**.

#### *Outlet 2*

- 1 Right-click **Outlet 1** and choose **Duplicate**.
- 2 In the **Settings** window for **Integration**, type Outlet 2 in the **Label** text field.
- 3 Locate the **Source Selection** section. From the **Selection** list, choose **Outlet 2**.

#### *Inlet 2*

- 1 Right-click **Outlet 2** and choose **Duplicate**.
- 2 In the **Settings** window for **Integration**, type Inlet 2 in the **Label** text field.
- 3 In the **Operator name** text field, type intopInlet2.
- 4 Locate the **Source Selection** section. From the **Selection** list, choose **Inlet 2**.

#### *Consumer Average*

- 1 In the **Definitions** toolbar, click  **Nonlocal Couplings** and choose **Average**.
- 2 In the **Settings** window for **Average**, type Consumer Average in the **Label** text field.
- 3 In the **Operator name** text field, type aveopConsumer.
- 4 Locate the **Source Selection** section. From the **Geometric entity level** list, choose **Edge**.
- 5 From the **Selection** list, choose **Consumers**.

#### *Consumer Minimum*

- 1 In the **Definitions** toolbar, click  **Nonlocal Couplings** and choose **Minimum**.
- 2 In the **Settings** window for **Minimum**, type Consumer Minimum in the **Label** text field.
- 3 Locate the **Source Selection** section. From the **Geometric entity level** list, choose **Point**.
- 4 From the **Selection** list, choose **Consumer Hot Points**.

### General Extrusion 1 (genext1)

- 1 In the **Definitions** toolbar, click  **Nonlocal Couplings** and choose **General Extrusion**.
- 2 In the **Settings** window for **General Extrusion**, locate the **Source Selection** section.
- 3 From the **Geometric entity level** list, choose **Edge**.
- 4 From the **Selection** list, choose **Hot Flow**.
- 5 Locate the **Destination Map** section. In the **z-expression** text field, type 0.

### General Extrusion 2 (genext2)

- 1 Right-click **General Extrusion 1 (genext1)** and choose **Duplicate**.
- 2 In the **Settings** window for **General Extrusion**, locate the **Source Selection** section.
- 3 From the **Geometric entity level** list, choose **Point**.
- 4 From the **Selection** list, choose **Consumer Hot Points**.

In the **Model Builder Window**, under **Component 1 (comp1) > Definitions**, Ctrl-click to select all nonlocal coupling operators. Then right-click and choose **Group**.

### Operators

- 1 In the **Model Builder** window, under **Component 1 (comp1) > Definitions** click **Group 1**.
- 2 In the **Settings** window for **Group**, type Operators in the **Label** text field.

### Pipe Cost

- 1 In the **Definitions** toolbar, click  **Analytic**.
- 2 In the **Settings** window for **Analytic**, type Pipe Cost in the **Label** text field.
- 3 In the **Function name** text field, type pipeCost.
- 4 Locate the **Definition** section. In the **Expression** text field, type  $2202 + (2922 - 2202) * (x - 0.032) / (0.4 - 0.032)$ .

The values are taken from [Ref. 2](#).

- 5 Locate the **Units** section. In the **Function** text field, type 1/m.
- 6 In the table, enter the following settings:

| Argument | Unit |
|----------|------|
| x        | m    |

### Hot Pipes

- 1 In the **Model Builder** window, right-click **Definitions** and choose **Variables**.
- 2 In the **Settings** window for **Variables**, type Hot Pipes in the **Label** text field.

- 3 Locate the **Geometric Entity Selection** section. From the **Geometric entity level** list, choose **Edge**.
- 4 From the **Selection** list, choose **Hot Flow**.
- 5 Locate the **Variables** section. In the table, enter the following settings:

| Name  | Expression                            | Unit | Description      |
|-------|---------------------------------------|------|------------------|
| qHeat | $k_{out} * (T_{out} - T)$             | W/m  | Thermal Coupling |
| pipeD | $d_{init} * \exp(\text{pipeControl})$ | m    | Pipe diameter    |

#### *Cold Pipes*

- 1 Right-click **Hot Pipes** and choose **Duplicate**.
- 2 In the **Settings** window for **Variables**, type Cold Pipes in the **Label** text field.
- 3 Locate the **Geometric Entity Selection** section. From the **Selection** list, choose **Cold Flow**.
- 4 Locate the **Variables** section. In the table, enter the following settings:

| Name  | Expression                     | Unit | Description   |
|-------|--------------------------------|------|---------------|
| pipeD | $\text{genext1}(\text{pipeD})$ | m    | Pipe diameter |

This enforces identical pipe diameters for hot and cold flows.

#### *Consumers*

- 1 Right-click **Cold Pipes** and choose **Duplicate**.
- 2 In the **Settings** window for **Variables**, type Consumers in the **Label** text field.
- 3 Locate the **Geometric Entity Selection** section. From the **Selection** list, choose **Consumers**.
- 4 Locate the **Variables** section. In the table, enter the following settings:

| Name  | Expression  | Unit | Description      |
|-------|---|------|------------------|
| qHeat | $\exp(\text{genext2}(\text{consumers})) * k_{room} * (roomT - T)$ | W/m  | Thermal coupling |
| pipeD | $\exp(\text{genext2}(\text{bypass})) * d_{init2}$                 | m    | Pipe diameter    |

#### *Inlet/Outlet*

- 1 Right-click **Consumers** and choose **Duplicate**.
- 2 In the **Settings** window for **Variables**, type Inlet/Outlet in the **Label** text field.
- 3 Locate the **Geometric Entity Selection** section. From the **Selection** list, choose **Inlets+ Outlets**.

4 Locate the **Variables** section. In the table, enter the following settings:

| Name  | Expression                    | Unit | Description      |
|-------|-------------------------------|------|------------------|
| qHeat | $k_{out} \cdot (T_{out} - T)$ | W/m  | Thermal coupling |
| pipeD | dInit                         | m    | Pipe diameter    |

### Objectives

1 In the **Model Builder** window, right-click **Definitions** and choose **Variables**.

2 In the **Settings** window for **Variables**, type Objectives in the **Label** text field.

You can import the table contents from district\_heating\_optimization\_variables.txt.

3 Locate the **Variables** section. In the table, enter the following settings:

| Name      | Expression  | Unit | Description             |
|-----------|---|------|-------------------------|
| constr    | $\log(\text{aveopConsumer}(\exp(p_{Exp} \cdot (1 + P/\text{consumerPower}^2))) / p_{Exp})$  |      | Constraint              |
| pipePrice | $2 \cdot \text{intopHot}(\text{pipeCost}(\text{pipeD}))$  |      | Pipe price [EUR]        |
| power1    | $\text{intopInlet1}((p - 1[\text{atm}]) \cdot \text{nipfl.Qv})$   | W    | Pumping power           |
| power2    | $\text{intopInlet2}((p - 1[\text{atm}]) \cdot \text{nipfl.Qv})$   | W    | Pumping power           |
| pumpPrice | $\text{pumpWeight} \cdot (\text{power1} + \text{power2})$   |      | Pumping price [EUR]     |
| obj       | $\text{pipePrice} + \text{pumpPrice}$   |      | Objective function      |
| flow1in   | $\text{intopInlet1}(\text{nipfl.Qm})$   | kg/s | Mass flow rate, Inlet 1 |
| flow2in   | $\text{intopInlet2}(\text{nipfl.Qm})$   | kg/s | Mass flow rate, Inlet 2 |
| Pin       | $\text{flow1in} \cdot \text{intopOutlet1}((T1 - T) \cdot \text{mat1.def.Cp}(T)) + \text{flow2in} \cdot \text{intopOutlet2}((T2 - T) \cdot \text{mat1.def.Cp}(T))$ | W    | Power input             |
| Pconsumer | $\text{intopConsumers}(-P/Lz)$  | W    | Total consumer power    |

| Name       | Expression       | Unit | Description        |
|------------|------------------|------|--------------------|
| Efficiency | Pconsumer/Pin    |      | Network efficiency |
| Pout       | intopAll(-qHeat) | W    | Total heat loss    |

## NONISOTHERMAL PIPE FLOW (NIPFL)

### *Pipe Properties 1*

- 1 In the **Model Builder** window, under **Component 1 (comp1)** > **Nonisothermal Pipe Flow (nipfl)** click **Pipe Properties 1**.
- 2 In the **Settings** window for **Pipe Properties**, locate the **Pipe Shape** section.
- 3 From the list, choose **Circular**.
- 4 In the  $d_i$  text field, type pipeD.

### *Pressure 1*

- 1 In the **Model Builder** window, click **Pressure 1**.
- 2 In the **Settings** window for **Pressure**, locate the **Boundary Pressure** section.
- 3 In the  $p_0$  text field, type 1[atm].

### *Temperature 1*

- 1 In the **Model Builder** window, click **Temperature 1**.
- 2 In the **Settings** window for **Temperature**, locate the **Temperature** section.
- 3 In the  $T_{in}$  text field, type T1.

### *Heat Source 1*

- 1 In the **Physics** toolbar, click  **Edges** and choose **Heat Source**.
- 2 In the **Settings** window for **Heat Source**, locate the **Edge Selection** section.
- 3 From the **Selection** list, choose **All edges**.
- 4 Locate the **Heat Source** section. In the  $Q_0$  text field, type qHeat.

### *Pressure 2*

- 1 In the **Physics** toolbar, click  **Points** and choose **Pressure**.
- 2 In the **Settings** window for **Pressure**, locate the **Point Selection** section.
- 3 From the **Selection** list, choose **Inlet 1**.
- 4 Locate the **Boundary Pressure** section. In the  $p_0$  text field, type 1[atm]+dp1\*exp(dp1c).

### *Pressure 3*

- 1 Right-click **Pressure 2** and choose **Duplicate**.
- 2 In the **Settings** window for **Pressure**, locate the **Point Selection** section.
- 3 From the **Selection** list, choose **Inlet 2**.
- 4 Locate the **Boundary Pressure** section. In the  $p_0$  text field, type  $1[\text{atm}]+dp2*\exp(dp2c)$ .

### *Temperature 2*

- 1 In the **Physics** toolbar, click  **Points** and choose **Temperature**.
- 2 In the **Settings** window for **Temperature**, locate the **Point Selection** section.
- 3 From the **Selection** list, choose **Inlet 2**.
- 4 Locate the **Temperature** section. In the  $T_{in}$  text field, type T2.

### *Heat Outflow 1*

- 1 In the **Physics** toolbar, click  **Points** and choose **Heat Outflow**.
- 2 In the **Settings** window for **Heat Outflow**, locate the **Point Selection** section.
- 3 From the **Selection** list, choose **Outlet 1**.

### *Heat Outflow 2*

- 1 Right-click **Heat Outflow 1** and choose **Duplicate**.
- 2 In the **Settings** window for **Heat Outflow**, locate the **Point Selection** section.
- 3 From the **Selection** list, choose **Outlet 2**.

## **AVERAGE CONSUMER POWER**

- 1 In the **Model Builder** window, under **Component 1 (comp1)** click **Coefficient Form Edge PDE (ce)**.
- 2 In the **Settings** window for **Coefficient Form Edge PDE**, type Average Consumer Power in the **Label** text field.
- 3 Locate the **Edge Selection** section. From the **Selection** list, choose **Consumers**.

### *Coefficient Form PDE 1*

- 1 In the **Model Builder** window, under **Component 1 (comp1)** > **Average Consumer Power (ce)** click **Coefficient Form PDE 1**.
- 2 In the **Settings** window for **Coefficient Form PDE**, locate the **Diffusion Coefficient** section.
- 3 In the  $c$  text field, type  $1e6*Lz^2$ .
- 4 Locate the **Absorption Coefficient** section. In the  $a$  text field, type 1.

- 5 Locate the **Source Term** section. In the  $f$  text field, type  $q_{\text{Heat}} * L_z$ .  
This effectively averages the power over each consumer.

## MESH 1

- 1 In the **Model Builder** window, under **Component 1 (comp1)** click **Mesh 1**.
- 2 In the **Settings** window for **Mesh**, locate the **Physics-Controlled Mesh** section.
- 3 From the **Element size** list, choose **Extremely fine**.

## STUDY 1: INITIAL DESIGN



- 1 In the **Model Builder** window, click **Study 1**.
- 2 In the **Settings** window for **Study**, type Study 1: Initial Design in the **Label** text field.
- 3 In the **Study** toolbar, click  **Get Initial Value**.

### *Solver Configurations*

In the **Model Builder** window, expand the **Study 1: Initial Design > Solver Configurations** node.

### *Solution 1 (sol1)*

Use a **Segregated** solver to improve robustness.

- 1 In the **Model Builder** window, expand the **Study 1: Initial Design > Solver Configurations > Solution 1 (sol1)** node.
- 2 Right-click **Stationary Solver 1** and choose **Segregated**.
- 3 Right-click **Segregated 1** and choose **Segregated Step**.
- 4 In the **Settings** window for **Segregated Step**, type Temperature in the **Label** text field.
- 5 Locate the **General** section. Under **Variables**, click  **Add**.
- 6 In the **Add** dialog, in the **Variables** list, choose **Control Variable Field (comp1.bypass)**, **Control Variable Field (comp1.consumers)**, **Control Variable Field (comp1.pipeControl)**, and **Temperature (comp1.T)**.
- 7 Click **OK**.
- 8 Right-click **Segregated 1** and choose **Segregated Step**.
- 9 In the **Settings** window for **Segregated Step**, type Power in the **Label** text field.
- 10 Locate the **General** section. Under **Variables**, click  **Add**.
- 11 In the **Add** dialog, in the **Variables** list, choose **Control Variable Field (comp1.bypass)**, **Control Variable Field (comp1.consumers)**, **Dependent Variable P (comp1.P)**, and **Control Variable Field (comp1.pipeControl)**.

12 Click **OK**.

13 In the **Model Builder** window, under **Study 1: Initial Design > Solver Configurations > Solution 1 (sol1) > Stationary Solver 1 > Segregated 1** click **Segregated Step**.

14 In the **Settings** window for **Segregated Step**, type **Flow** in the **Label** text field.

15 Locate the **General** section. In the **Variables** list, choose **Dependent Variable P (comp1.P)** and **Temperature (comp1.T)**.

16 Under **Variables**, click  **Delete**.

17 In the **Study** toolbar, click  **Compute**.

## RESULTS

### *Average Consumer Power*

In the **Model Builder** window, under **Results** right-click **Average Consumer Power** and choose **Delete**.

### *Arrow Line 1*

1 In the **Model Builder** window, expand the **Results > Velocity (nipfl)** node, then click **Arrow Line 1**.

2 In the **Settings** window for **Arrow Line**, locate the **Arrow Positioning** section.

3 From the **Placement** list, choose **Gauss points**.

4 In the **Velocity (nipfl)** toolbar, click  **Plot**.

### *Line 1*

1 In the **Model Builder** window, expand the **Results > Temperature (nipfl)** node, then click **Line 1**.

2 In the **Settings** window for **Line**, locate the **Expression** section.

3 In the **Unit** field, type **degC**.

4 In the **Temperature (nipfl)** toolbar, click  **Plot**.

### *Pressure (nipfl), Temperature (nipfl), Velocity (nipfl)*



1 In the **Model Builder** window, under **Results**, Ctrl-click to select **Pressure (nipfl)**, **Velocity (nipfl)**, and **Temperature (nipfl)**.

2 Right-click and choose **Group**.

### *Initial Design*

In the **Settings** window for **Group**, type **Initial Design** in the **Label** text field.

## ADD STUDY

- 1 In the **Home** toolbar, click  **Add Study** to open the **Add Study** window.
- 2 Go to the **Add Study** window.
- 3 Find the **Studies** subsection. In the **Select Study** tree, select **General Studies > Stationary**.
- 4 Click the **Add Study** button in the window toolbar.
- 5 Click the **Add Study** button in the window toolbar.
- 6 In the **Home** toolbar, click  **Add Study** to close the **Add Study** window.

## STUDY 2

### *General Optimization*

- 1 In the **Study** toolbar, click  **Optimization** and choose **General Optimization**.
- 2 In the **Settings** window for **General Optimization**, locate the **Optimization Solver** section.
- 3 From the **Method** list, choose **GCMMA**.
- 4 In the **Maximum number of model evaluations** text field, type 50.  
The controls are logarithmic, so enabling move limits prevents **MMA** from making relative adjustments larger than  $\exp(0.1)$ . This improves robustness of the optimization.  
Start out by varying the bypass and consumer controls, so that the constraint is minimized.
- 5 Click **Add Expression** in the upper-right corner of the **Objective Function** section. From the menu, choose **Component 1 (comp1) > Definitions > Variables > comp1.constr - Constraint**.
- 6 Locate the **Objective Function** section. In the table, enter the following settings:

| Expression                       | Description | Evaluate for |
|----------------------------------|-------------|--------------|
| $\log_{10}(\text{comp1.constr})$ | Constraint  | Stationary   |

- 7 In the **Model Builder** window, click **Study 2**.
- 8 In the **Settings** window for **Study**, locate the **Study Settings** section.
- 9 Clear the **Generate default plots** checkbox.
- 10 In the **Label** text field, type Study 2: Feasible Design.
- 11 In the **Study** toolbar, click  **Get Initial Value**.

### *Solver Configurations*

In the **Model Builder** window, expand the **Study 2: Feasible Design > Solver Configurations** node.

#### *Solution 2 (sol2)*

- 1 In the **Model Builder** window, expand the **Study 2: Feasible Design > Solver Configurations > Solution 2 (sol2)** node, then click **Optimization Solver I**.
- 2 In the **Settings** window for **Optimization Solver**, locate the **Optimization Solver** section.
- 3 Select the **Move limits** checkbox.
- 4 In the **Model Builder** window, expand the **Study 2: Feasible Design > Solver Configurations > Solution 2 (sol2) > Optimization Solver I** node.
- 5 Right-click **Stationary Solver I** and choose **Segregated**.
- 6 In the **Model Builder** window, expand the **Study 2: Feasible Design > Solver Configurations > Solution 2 (sol2) > Optimization Solver I > Stationary Solver I > Segregated I** node.
- 7 Right-click **Segregated I** and choose **Segregated Step**.
- 8 In the **Model Builder** window, collapse the **Study 2: Feasible Design > Solver Configurations > Solution 2 (sol2) > Optimization Solver I > Stationary Solver I > Segregated I** node.
- 9 In the **Model Builder** window, under **Study 2: Feasible Design > Solver Configurations > Solution 2 (sol2) > Optimization Solver I > Stationary Solver I > Segregated I** click **Segregated Step I**.
- 10 In the **Settings** window for **Segregated Step**, type Temperature in the **Label** text field.
- 11 Locate the **General** section. Under **Variables**, click **+ Add**.
- 12 In the **Add** dialog, in the **Variables** list, choose **Control Variable Field (comp1.bypass)**, **Control Variable Field (comp1.consumers)**, **Control Variable Field (comp1.pipeControl)**, and **Temperature (comp1.T)**.
- 13 Click **OK**.
- 14 In the **Model Builder** window, right-click **Segregated I** and choose **Segregated Step**.
- 15 In the **Settings** window for **Segregated Step**, type Power in the **Label** text field.
- 16 Locate the **General** section. Under **Variables**, click **+ Add**.
- 17 In the **Add** dialog, in the **Variables** list, choose **Control Variable Field (comp1.bypass)**, **Control Variable Field (comp1.consumers)**, **Dependent Variable P (comp1.P)**, and **Control Variable Field (comp1.pipeControl)**.
- 18 Click **OK**.

- 19 In the **Model Builder** window, under **Study 2: Feasible Design > Solver Configurations > Solution 2 (sol2) > Optimization Solver 1 > Stationary Solver 1 > Segregated 1** click **Segregated Step**.
- 20 In the **Settings** window for **Segregated Step**, type Flow in the **Label** text field.
- 21 Locate the **General** section. In the **Variables** list, choose **Dependent Variable P (comp1.P)** and **Temperature (comp1.T)**.
- 22 Under **Variables**, click  **Delete**.
- 23 In the **Model Builder** window, click **Direct 2**.
- 24 In the **Settings** window for **Direct**, locate the **General** section.
- 25 From the **Solver** list, choose **PARDISO**.

## RESULTS

*Pressure (nipfl), Temperature (nipfl), Velocity (nipfl)*

- 1 In the **Model Builder** window, under **Results > Initial Design**, Ctrl-click to select **Pressure (nipfl)**, **Velocity (nipfl)**, and **Temperature (nipfl)**.
- 2 Right-click and choose **Duplicate**.

*Pressure (nipfl) 1, Temperature (nipfl) 1, Velocity (nipfl) 1*

Right-click and choose **Move Out**.

*Pressure (nipfl) 1*

- 1 In the **Settings** window for **3D Plot Group**, locate the **Data** section.
- 2 From the **Dataset** list, choose **Study 2: Feasible Design/Solution 2 (sol2)**.

*Velocity (nipfl) 1*

- 1 In the **Model Builder** window, click **Velocity (nipfl) 1**.
- 2 In the **Settings** window for **3D Plot Group**, locate the **Data** section.
- 3 From the **Dataset** list, choose **Study 2: Feasible Design/Solution 2 (sol2)**.

*Temperature (nipfl) 1*

- 1 In the **Model Builder** window, click **Temperature (nipfl) 1**.
- 2 In the **Settings** window for **3D Plot Group**, locate the **Data** section.
- 3 From the **Dataset** list, choose **Study 2: Feasible Design/Solution 2 (sol2)**.

Create a plot for showing the consumer powers during the initial optimization.

*Power*

- 1 In the **Results** toolbar, click  **3D Plot Group**.

- 2 In the **Settings** window for **3D Plot Group**, type **Power** in the **Label** text field.
- 3 Locate the **Data** section. From the **Dataset** list, choose **Study 2: Feasible Design/ Solution 2 (sol2)**.

#### *Line 1*

- 1 Right-click **Power** and choose **Line**.
- 2 In the **Settings** window for **Line**, locate the **Expression** section.
- 3 In the **Expression** text field, type **-P**.
- 4 Click to expand the **Range** section. Select the **Manual color range** checkbox.
- 5 In the **Minimum** text field, type **0.8\*consumerPower**.
- 6 In the **Maximum** text field, type **1.2\*consumerPower**.
- 7 Locate the **Coloring and Style** section. From the **Line type** list, choose **Tube**.
- 8 In the **Tube radius expression** text field, type **5**.
- 9 Select the **Radius scale factor** checkbox.
- 10 From the **Color table** list, choose **ThermalDark**.

#### *Power, Pressure (nipfl) 1, Temperature (nipfl) 1, Velocity (nipfl) 1*

- 1 In the **Model Builder** window, under **Results**, Ctrl-click to select **Pressure (nipfl) 1**, **Velocity (nipfl) 1**, **Temperature (nipfl) 1**, and **Power**.
- 2 Right-click and choose **Group**.

#### *Feasible Design*

In the **Settings** window for **Group**, type **Feasible Design** in the **Label** text field.

### **STUDY 2: FEASIBLE DESIGN**

#### *General Optimization*

- 1 In the **Model Builder** window, under **Study 2: Feasible Design** click **General Optimization**.
- 2 In the **Settings** window for **General Optimization**, click to expand the **Output** section.
- 3 Select the **Plot** checkbox.
- 4 From the **Plot group** list, choose **Power**.
- 5 In the **Study** toolbar, click  **Compute**.



### **RESULTS**

#### *Feasible Design*

- 1 In the **Results** toolbar, click  **Evaluation Group**.



- 2 In the **Settings** window for **Evaluation Group**, type Feasible Design in the **Label** text field.
- 3 Locate the **Data** section. From the **Dataset** list, choose **Study 2: Feasible Design/ Solution 2 (sol2)**.

#### *Global Evaluation I*

- 1 Right-click **Feasible Design** and choose **Global Evaluation**.
- 2 In the **Settings** window for **Global Evaluation**, locate the **Expressions** section.
- 3 Click  **Clear Table**.
- 4 Click **Add Expression** in the upper-right corner of the **Expressions** section. From the menu, choose **Component I (comp1) > Definitions > Variables > Efficiency - Network efficiency - I**.
- 5 Click **Add Expression** in the upper-right corner of the **Expressions** section. From the menu, choose **Component I (comp1) > Definitions > Variables > pumpPrice - Pump price [EUR] - I**.
- 6 Click **Add Expression** in the upper-right corner of the **Expressions** section. From the menu, choose **Component I (comp1) > Definitions > Variables > pipePrice - Pipe price [EUR] - I**.
- 7 In the **Feasible Design** toolbar, click  **Evaluate**.

### **STUDY 3**

#### *General Optimization*

- 1 In the **Study** toolbar, click  **Optimization** and choose **General Optimization**.
- 2 In the **Settings** window for **General Optimization**, locate the **Optimization Solver** section.
- 3 From the **Method** list, choose **MMA**.
- 4 In the **Maximum number of model evaluations** text field, type 2000.
- 5 Click **Add Expression** in the upper-right corner of the **Objective Function** section. From the menu, choose **Component I (comp1) > Definitions > Variables > comp1.obj - Objective function - I**.
- 6 Locate the **Control Variables and Parameters** section. Click  **Add** twice.

7 In the table, enter the following settings:

| Parameter            | Initial value | Scale | Lower bound | Upper bound | Unit |
|----------------------|---------------|-------|-------------|-------------|------|
| dp1c (Inlet control) | 0             | 1     | log(0.1)    | log(10)     |      |
| dp2c (Inlet control) | 0             | 1     | log(0.1)    | log(10)     |      |

8 Click **Add Expression** in the upper-right corner of the **Constraints** section. From the menu, choose **Component 1 (comp1) > Definitions > Variables > comp1.constr - Constraint**.

9 Locate the **Constraints** section. In the table, enter the following settings:

| Expression                 | Lower bound | Upper bound | Evaluate for |
|----------------------------|-------------|-------------|--------------|
| log10(comp1.constr / 1e-3) |             | 0           | Stationary   |

10 Click to expand the **Solver Settings** section. Find the **Objective settings** subsection. From the **Objective scaling** list, choose **Initial solution based**.

11 In the **Model Builder** window, click **Study 3**.

12 In the **Settings** window for **Study**, type Study 3: Optimization in the **Label** text field.

13 Locate the **Study Settings** section. Clear the **Generate default plots** checkbox.

14 In the **Study** toolbar, click  **Get Initial Value**.

#### *Solver Configurations*

In the **Model Builder** window, expand the **Study 3: Optimization > Solver Configurations** node.

#### *Solution 3 (sol3)*

1 In the **Model Builder** window, expand the **Study 3: Optimization > Solver Configurations > Solution 3 (sol3) > Optimization Solver 1** node.



2 Right-click **Stationary Solver 1** and choose **Segregated**.

3 Right-click **Segregated 1** and choose **Segregated Step**.

4 In the **Settings** window for **Segregated Step**, type Temperature in the **Label** text field.

5 Locate the **General** section. Under **Variables**, click  **Add**.

6 In the **Add** dialog, in the **Variables** list, choose **Control Variable Field (comp1.bypass)**, **Control Variable Field (comp1.consumers)**, **Control Variable Field (comp1.pipeControl)**, and **Temperature (comp1.T)**.

- 7 Click **OK**.
- 8 Right-click **Segregated 1** and choose **Segregated Step**.
- 9 In the **Settings** window for **Segregated Step**, type Power in the **Label** text field.
- 10 Locate the **General** section. Under **Variables**, click  **Add**.
- 11 In the **Add** dialog, in the **Variables** list, choose **Control Variable Field (comp1.bypass)**, **Control Variable Field (comp1.consumers)**, **Dependent Variable P (comp1.P)**, and **Control Variable Field (comp1.pipeControl)**.
- 12 Click **OK**.
- 13 In the **Model Builder** window, under **Study 3: Optimization > Solver Configurations > Solution 3 (sol3) > Optimization Solver 1 > Stationary Solver 1 > Segregated 1** click **Segregated Step**.
- 14 In the **Settings** window for **Segregated Step**, type Flow in the **Label** text field.
- 15 Locate the **General** section. In the **Variables** list, choose **Dependent Variable P (comp1.P)** and **Temperature (comp1.T)**.
- 16 Under **Variables**, click  **Delete**.
- 17 In the **Model Builder** window, click **Direct 2**.
- 18 In the **Settings** window for **Direct**, locate the **General** section.
- 19 From the **Solver** list, choose **PARDISO**.

## RESULTS

*Power, Pressure (nipfl) 1, Temperature (nipfl) 1, Velocity (nipfl) 1*

- 1 In the **Model Builder** window, under **Results > Feasible Design**, Ctrl-click to select **Pressure (nipfl) 1**, **Velocity (nipfl) 1**, **Temperature (nipfl) 1**, and **Power**.
- 2 Right-click and choose **Duplicate**.

*Power 1, Pressure (nipfl) 1.1, Temperature (nipfl) 1.1, Velocity (nipfl) 1.1*

Right-click and choose **Move Out**.

*Pressure (nipfl) 2*

- 1 In the **Settings** window for **3D Plot Group**, type Pressure (nipfl) 2 in the **Label** text field.
- 2 Locate the **Data** section. From the **Dataset** list, choose **Study 3: Optimization/ Solution 3 (sol3)**.

*Velocity (nipfl) 2*

- 1 In the **Model Builder** window, under **Results** click **Velocity (nipfl) 1.1**.

- 2 In the **Settings** window for **3D Plot Group**, type Velocity (nipfl) 2 in the **Label** text field.
- 3 Locate the **Data** section. From the **Dataset** list, choose **Study 3: Optimization/Solution 3 (sol3)**.

#### *Temperature (nipfl) 2*

- 1 In the **Model Builder** window, click **Temperature (nipfl) 1.1**.
- 2 In the **Settings** window for **3D Plot Group**, locate the **Data** section.
- 3 From the **Dataset** list, choose **Study 3: Optimization/Solution 3 (sol3)**.
- 4 In the **Label** text field, type Temperature (nipfl) 2.

#### *Power and Pipe Diameters*

- 1 In the **Model Builder** window, under **Results** click **Power 1**.
- 2 In the **Settings** window for **3D Plot Group**, type Power and Pipe Diameters in the **Label** text field.
- 3 Locate the **Data** section. From the **Dataset** list, choose **Study 3: Optimization/Solution 3 (sol3)**.
- 4 Click to expand the **Title** section. From the **Title type** list, choose **Label**.
- 5 Locate the **Plot Settings** section. Clear the **Plot dataset edges** checkbox.

Add the pipe diameters to the plot, so that you can use the plot to visualize the network topology during the optimization.

#### *Line 2*

- 1 Right-click **Power and Pipe Diameters** and choose **Line**.
- 2 In the **Settings** window for **Line**, click **Replace Expression** in the upper-right corner of the **Expression** section. From the menu, choose **Component 1 (comp1) > Nonisothermal Pipe Flow > Pipe properties > nipfl.dh - Hydraulic diameter - m**.
- 3 Locate the **Coloring and Style** section. From the **Line type** list, choose **Tube**.
- 4 Click the  button. From the menu, choose **Component 1 (comp1) > Nonisothermal Pipe Flow > Pipe properties > nipfl.dh - Hydraulic diameter - m**.
- 5 In the **Tube radius expression** text field, type  $\text{nipfl.dh}/2$ .
- 6 Select the **Radius scale factor** checkbox. In the associated text field, type 200.
- 7 Click to expand the **Quality** section. From the **Evaluation settings** list, choose **Manual**.
- 8 From the **Smoothing** list, choose **None**.

### Selection 1

- 1 Right-click **Line 2** and choose **Selection**.

The hot and cold flows have equal diameters, so you can simplify the plot by only plotting the diameters for the hot flow.

- 2 In the **Settings** window for **Selection**, locate the **Selection** section.
- 3 From the **Selection** list, choose **Hot Flow**.



### Power and Pipe Diameters

Next, display the pressures, the consumer power range, as well as the consumer and bypass control ranges.

### Annotation 1

- 1 In the **Model Builder** window, right-click **Power and Pipe Diameters** and choose **Annotation**.
- 2 In the **Settings** window for **Annotation**, locate the **Annotation** section.
- 3 In the **Text** text field, type  $\text{eval}(dp1*\exp(dp1c),kPa) \text{ kPa}, \text{eval}(dp2*\exp(dp2c),kPa) \text{ kPa}, P=[\text{eval}(\text{minop1}(-P),kW), \text{eval}(-\text{minop1}(P),kW)] \text{ kW}$ .
- 4 From the **Geometry level** list, choose **Global**.
- 5 Locate the **Position** section. In the **X** text field, type 20.
- 6 In the **Y** text field, type 285.
- 7 Click to expand the **Advanced** section. In the **Precision** text field, type 3.
- 8 Locate the **Coloring and Style** section. Clear the **Show point** checkbox.
- 9 From the **Background color** list, choose **Green**.

### Annotation 2

- 1 Right-click **Annotation 1** and choose **Duplicate**.
- 2 In the **Settings** window for **Annotation**, locate the **Annotation** section.
- 3 In the **Text** text field, type  $c0=[\text{eval}(\text{minop1}(\exp(\text{bypass}))), \text{eval}(-\text{minop1}(-\exp(\text{bypass})))], c1=[\text{eval}(\text{minop1}(\exp(\text{consumers}))), \text{eval}(-\text{minop1}(-\exp(\text{consumers})))]$ .
- 4 Locate the **Position** section. In the **Y** text field, type 250.
- 5 Click the  **Go to XY View** button in the **Graphics** toolbar.
- 6 Click the  **Zoom Extents** button in the **Graphics** toolbar.

### Bypass

- 1 In the **Results** toolbar, click  **3D Plot Group**.

- 2 In the **Settings** window for **3D Plot Group**, type **Bypass** in the **Label** text field.
- 3 Locate the **Data** section. From the **Dataset** list, choose **Study 3: Optimization/ Solution 3 (sol3)**.

#### *Line 1*

- 1 Right-click **Bypass** and choose **Line**.
- 2 In the **Settings** window for **Line**, locate the **Expression** section.
- 3 In the **Expression** text field, type `genext2(exp(bypass))`.
- 4 Locate the **Coloring and Style** section. From the **Line type** list, choose **Tube**.
- 5 Select the **Radius scale factor** checkbox. In the associated text field, type 10.

#### *Bypass*

- 1 In the **Model Builder** window, click **Bypass**.
- 2 In the **Settings** window for **3D Plot Group**, locate the **Title** section.
- 3 From the **Title type** list, choose **Label**.

#### *Consumers*

- 1 Right-click **Bypass** and choose **Duplicate**.
- 2 In the **Model Builder** window, click **Bypass 1**.
- 3 In the **Settings** window for **3D Plot Group**, type **Consumers** in the **Label** text field.

#### *Line 1*

- 1 In the **Model Builder** window, click **Line 1**.
- 2 In the **Settings** window for **Line**, locate the **Expression** section.
- 3 In the **Expression** text field, type `genext2(exp(consumers))`.

#### *Bypass, Consumers, Power and Pipe Diameters, Pressure (nipfl) 2, Temperature (nipfl) 2, Velocity (nipfl) 2*

- 1 In the **Model Builder** window, under **Results**, Ctrl-click to select **Pressure (nipfl) 2**, **Velocity (nipfl) 2**, **Temperature (nipfl) 2**, **Power and Pipe Diameters**, **Bypass**, and **Consumers**.
- 2 Right-click and choose **Group**.

#### *Optimization*

In the **Settings** window for **Group**, type **Optimization** in the **Label** text field.

## STUDY 3: OPTIMIZATION

### *General Optimization*

- 1 In the **Model Builder** window, under **Study 3: Optimization** click **General Optimization**.
- 2 In the **Settings** window for **General Optimization**, locate the **Output** section.
- 3 Select the **Plot** checkbox.
- 4 From the **Plot group** list, choose **Power and Pipe Diameters**.

### *Step 1: Stationary*

- 1 In the **Model Builder** window, click **Step 1: Stationary**.
- 2 In the **Settings** window for **Stationary**, click to expand the **Values of Dependent Variables** section.
- 3 Find the **Initial values of variables solved for** subsection. From the **Settings** list, choose **User controlled**.
- 4 From the **Method** list, choose **Solution**.
- 5 From the **Study** list, choose **Study 2: Feasible Design, Stationary**.

### *Solution 3 (sol3)*

- 1 In the **Model Builder** window, under **Study 3: Optimization > Solver Configurations > Solution 3 (sol3)** click **Optimization Solver 1**.
- 2 In the **Settings** window for **Optimization Solver**, locate the **Optimization Solver** section.
- 3 Select the **Move limits** checkbox.
- 4 In the **Study** toolbar, click  **Compute**.



## RESULTS

### *Optimization*



- 1 In the **Model Builder** window, right-click **Feasible Design** and choose **Duplicate**.
- 2 In the **Settings** window for **Evaluation Group**, type **Optimization** in the **Label** text field.
- 3 Locate the **Data** section. From the **Dataset** list, choose **Study 3: Optimization/Solution 3 (sol3)**.
- 4 In the **Optimization** toolbar, click  **Evaluate**.

It is not possible to reduce the total pipe price too much, because there are consumers everywhere and the price is more related to the digging than the actual price of the pipes. It is however possible to reduce the pumping price significantly as well as the network efficiency.



### *Line 1*

- 1 In the **Model Builder** window, expand the **Results > Optimization > Bypass** node, then click **Line 1**.
- 2 In the **Settings** window for **Line**, locate the **Range** section.
- 3 Select the **Manual color range** checkbox.
- 4 In the **Maximum** text field, type 2.
- 5 In the **Bypass** toolbar, click  **Plot**.
- 6 Click the  **Zoom Extents** button in the **Graphics** toolbar.

### *Consumers*

- 1 In the **Model Builder** window, under **Results > Optimization** click **Consumers**.
- 2 In the **Consumers** toolbar, click  **Plot**.
- 3 Click the  **Zoom Extents** button in the **Graphics** toolbar.

### *Power and Pipe Diameters*

- 1 In the **Model Builder** window, click **Power and Pipe Diameters**.
- 2 In the **Power and Pipe Diameters** toolbar, click  **Plot**.
- 3 Click the  **Zoom Extents** button in the **Graphics** toolbar.

## *Geometry Modeling Instructions*

---

From the **File** menu, choose **New**.

### **NEW**

In the **New** window, click  **Blank Model**.

### **ADD COMPONENT**

In the **Home** toolbar, click  **Add Component** and choose **3D**.

### **GLOBAL DEFINITIONS**

#### *Geometrical Parameters*

- 1 In the **Model Builder** window, under **Global Definitions** click **Parameters 1**.
- 2 In the **Settings** window for **Parameters**, type Geometrical Parameters in the **Label** text field.
- 3 Locate the **Parameters** section. Click  **Load from File**.

- 4 Browse to the model's Application Libraries folder and double-click the file `district_heating_optimization_geom_parameters.txt`.

## GEOMETRY I

### Block

- 1 In the **Geometry** toolbar, click  **More Primitives** and choose **Polygon**.
- 2 In the **Settings** window for **Polygon**, type Block in the **Label** text field.
- 3 Locate the **Object Type** section. From the **Type** list, choose **Closed curve**.
- 4 Locate the **Coordinates** section. In the table, enter the following settings:

| x (m)       | y (m)       | z (m) |
|-------------|-------------|-------|
| 0           | 0           | 0     |
| 0           | $nyBlock*W$ | 0     |
| $nxBlock*L$ | $nyBlock*W$ | 0     |
| $nxBlock*L$ | 0           | 0     |

- 5 Locate the **Selections of Resulting Entities** section. Select the **Resulting objects selection** checkbox.

### Move 1 (mov1)

- 1 In the **Geometry** toolbar, click  **Transforms** and choose **Move**.
- 2 In the **Settings** window for **Move**, locate the **Input** section.
- 3 From the **Input objects** list, choose **Block**.
- 4 Select the **Keep input objects** checkbox.
- 5 Locate the **Displacement** section. In the **z** text field, type  $Lz$ .

### Consumer 1

- 1 In the **Geometry** toolbar, click  **More Primitives** and choose **Polygon**.
- 2 In the **Settings** window for **Polygon**, type Consumer 1 in the **Label** text field.
- 3 Locate the **Coordinates** section. In the table, enter the following settings:

| x (m) | y (m) | z (m) |
|-------|-------|-------|
| $L/2$ | 0     | 0     |
| $L/2$ | 0     | $Lz$  |

- 4 Locate the **Selections of Resulting Entities** section. Select the **Resulting objects selection** checkbox.

### Consumer 2

- 1 Right-click **Consumer 1** and choose **Duplicate**.
- 2 In the **Settings** window for **Polygon**, type Consumer 2 in the **Label** text field.
- 3 Locate the **Coordinates** section. In the table, enter the following settings:

| x (m) | y (m) | z (m) |
|-------|-------|-------|
| 0     | 1.5*W | 0     |
| 0     | 1.5*W | Lz    |



### Array 1 (arr1)

- 1 In the **Geometry** toolbar, click  **Transforms** and choose **Array**.
- 2 In the **Settings** window for **Array**, locate the **Input** section.
- 3 From the **Input objects** list, choose **Consumer 1**.
- 4 Locate the **Size** section. In the **x size** text field, type  $n \times \text{Block}$ .
- 5 In the **y size** text field, type 2.
- 6 Locate the **Displacement** section. In the **x** text field, type L.
- 7 In the **y** text field, type  $n \times \text{Block} * W$ .

### Array 2 (arr2)

- 1 In the **Geometry** toolbar, click  **Transforms** and choose **Array**.
- 2 In the **Settings** window for **Array**, locate the **Input** section.
- 3 From the **Input objects** list, choose **Consumer 2**.
- 4 Locate the **Size** section. In the **x size** text field, type 2.
- 5 In the **y size** text field, type  $n \times \text{Block} - 2$ .
- 6 Locate the **Displacement** section. In the **x** text field, type  $n \times \text{Block} * L$ .
- 7 In the **y** text field, type W.

### Block+Consumers

- 1 In the **Geometry** toolbar, click  **Selections** and choose **Union Selection**.
- 2 In the **Settings** window for **Union Selection**, type Block+Consumers in the **Label** text field.
- 3 Locate the **Geometric Entity Level** section. From the **Level** list, choose **Edge**.
- 4 Locate the **Input Entities** section. Click  **Add**.
- 5 In the **Add** dialog, in the **Selections to add** list, choose **Block**, **Consumer 1**, and **Consumer 2**.
- 6 Click **OK**.



### Array 3 (arr3)

In the **Geometry** toolbar, click  **Transforms** and choose **Array**.

### Block+Consumers (unisel1)

- 1 In the **Model Builder** window, click **Block+Consumers (unisel1)**.
- 2 In the **Settings** window for **Union Selection**, locate the **Geometric Entity Level** section.
- 3 From the **Level** list, choose **Object**.
- 4 Locate the **Input Entities** section. Click  **Add**.
- 5 In the **Add** dialog, in the **Selections to add** list, choose **Block**, **Consumer 1**, and **Consumer 2**.
- 6 Click **OK**.

### Array 3 (arr3)

- 1 In the **Model Builder** window, click **Array 3 (arr3)**.
- 2 In the **Settings** window for **Array**, locate the **Input** section.
- 3 Click to select the  **Activate Selection** toggle button for **Input objects**.
- 4 From the **Input objects** list, choose **Block+Consumers**.
- 5 Locate the **Size** section. In the **x size** text field, type  $n \times \text{Blocks}$ .
- 6 In the **y size** text field, type  $n \times \text{Blocks}$ .
- 7 Locate the **Displacement** section. In the **x** text field, type  $n \times \text{Block} \times L$ .
- 8 In the **y** text field, type  $n \times \text{Block} \times W$ .
- 9 Click  **Build Selected**.

### Inlet 1 Line

- 1 In the **Model Builder** window, under **Component 1 (comp1) > Geometry 1** right-click **Consumer 2 (pol3)** and choose **Duplicate**.
- 2 In the **Settings** window for **Polygon**, type Inlet 1 Line in the **Label** text field.
- 3 Locate the **Coordinates** section. In the table, enter the following settings:

| x (m)      | y (m)      | z (m) |
|------------|------------|-------|
| producer1x | producer1y | 0     |
| producer1x | producer1y | Lz/3  |

### Outlet 1 Line

- 1 Right-click **Inlet 1 Line** and choose **Duplicate**.
- 2 In the **Settings** window for **Polygon**, type Outlet 1 Line in the **Label** text field.

3 Locate the **Coordinates** section. In the table, enter the following settings:

| x (m)      | y (m)      | z (m)  |
|------------|------------|--------|
| producer1x | producer1y | Lz     |
| producer1x | producer1y | 2*Lz/3 |

*Outlet 2 Line*

- 1 Right-click **Outlet 1 Line** and choose **Duplicate**.
- 2 In the **Settings** window for **Polygon**, type Outlet 2 Line in the **Label** text field.
- 3 Locate the **Coordinates** section. In the table, enter the following settings:

| x (m)      | y (m)      | z (m)  |
|------------|------------|--------|
| producer2x | producer2y | Lz     |
| producer2x | producer2y | 2*Lz/3 |

*Inlet 2 Line*

- 1 Right-click **Outlet 2 Line** and choose **Duplicate**.
- 2 In the **Settings** window for **Polygon**, type Inlet 2 Line in the **Label** text field.
- 3 Locate the **Coordinates** section. In the table, enter the following settings:

| x (m)      | y (m)      | z (m) |
|------------|------------|-------|
| producer2x | producer2y | 0     |
| producer2x | producer2y | Lz/3  |

*Form Union (fin)*

- 1 In the **Model Builder** window, click **Form Union (fin)**.
- 2 In the **Settings** window for **Form Union/Assembly**, click  **Build Selected**.

*Inlet 1*

- 1 In the **Geometry** toolbar, click  **Selections** and choose **Ball Selection**.
- 2 In the **Settings** window for **Ball Selection**, type Inlet 1 in the **Label** text field.
- 3 Locate the **Geometric Entity Level** section. From the **Level** list, choose **Point**.
- 4 Locate the **Ball Center** section. In the **x** text field, type producer1x.
- 5 In the **y** text field, type producer1y.
- 6 In the **z** text field, type Lz/3.
- 7 Locate the **Ball Radius** section. In the **Radius** text field, type Lz/100.

- 8 Locate the **Output Entities** section. From the **Include entity if** list, choose **Entity inside ball**.

#### *Outlet 1*

- 1 Right-click **Inlet 1** and choose **Duplicate**.
- 2 In the **Settings** window for **Ball Selection**, type Outlet 1 in the **Label** text field.
- 3 Locate the **Ball Center** section. In the **z** text field, type  $2*Lz/3$ .



#### *Outlet 2*

- 1 Right-click **Outlet 1** and choose **Duplicate**.
- 2 In the **Settings** window for **Ball Selection**, type Outlet 2 in the **Label** text field.
- 3 Locate the **Ball Center** section. In the **x** text field, type  $producer2x$ .
- 4 In the **y** text field, type  $producer2y$ .

#### *Inlet 2*

- 1 Right-click **Outlet 2** and choose **Duplicate**.
- 2 In the **Settings** window for **Ball Selection**, type Inlet 2 in the **Label** text field.
- 3 Locate the **Ball Center** section. In the **z** text field, type  $Lz/3$ .

#### *Consumers*

- 1 In the **Geometry** toolbar, click  **Selections** and choose **Union Selection**.
- 2 In the **Settings** window for **Union Selection**, type Consumers in the **Label** text field.
- 3 Locate the **Geometric Entity Level** section. From the **Level** list, choose **Edge**.
- 4 Locate the **Input Entities** section. Click  **Add**.
- 5 In the **Add** dialog, in the **Selections to add** list, choose **Consumer 1** and **Consumer 2**.
- 6 Click **OK**.

#### *Hot Flow*



- 1 In the **Geometry** toolbar, click  **Selections** and choose **Box Selection**.
- 2 In the **Settings** window for **Box Selection**, type Hot Flow in the **Label** text field.
- 3 Locate the **Geometric Entity Level** section. From the **Level** list, choose **Edge**.
- 4 Locate the **Box Limits** section. In the **z maximum** text field, type  $Lz/100$ .
- 5 Locate the **Output Entities** section. From the **Include entity if** list, choose **Entity inside box**.

#### *Cold Flow*

- 1 Right-click **Hot Flow** and choose **Duplicate**.

- 2 In the **Settings** window for **Box Selection**, type Cold Flow in the **Label** text field.
- 3 Locate the **Box Limits** section. In the **z maximum** text field, type Inf.
- 4 In the **z minimum** text field, type  $Lz*99/100$ .
- 5 Click  **Build Selected**.



#### *Consumer Points*

- 1 In the **Geometry** toolbar, click  **Selections** and choose **Adjacent Selection**.
- 2 In the **Settings** window for **Adjacent Selection**, type Consumer Points in the **Label** text field.
- 3 Locate the **Input Entities** section. From the **Geometric entity level** list, choose **Edge**.
- 4 Locate the **Output Entities** section. From the **Geometric entity level** list, choose **Adjacent points**.
- 5 Locate the **Input Entities** section. Click  **Add**.
- 6 In the **Add** dialog, select **Consumers** in the **Input selections** list.
- 7 Click **OK**.
- 8 In the **Settings** window for **Adjacent Selection**, click  **Build Selected**.

#### *Consumer Hot Points*

- 1 In the **Model Builder** window, under **Component 1 (comp1) > Geometry 1** right-click **Hot Flow (boxsel1)** and choose **Duplicate**.
- 2 In the **Settings** window for **Box Selection**, type Consumer Hot Points in the **Label** text field.
- 3 Locate the **Geometric Entity Level** section. From the **Level** list, choose **Point**.
- 4 Locate the **Input Entities** section. From the **Entities** list, choose **From selections**.
- 5 Click  **Add**.
- 6 In the **Add** dialog, in the **Selections** list, choose **Consumer 1** and **Consumer 2**.
- 7 Click **OK**.

#### *Inlets+Outlets*

- 1 In the **Geometry** toolbar, click  **Selections** and choose **Union Selection**.
- 2 In the **Settings** window for **Union Selection**, type Inlets+Outlets in the **Label** text field.
- 3 Locate the **Geometric Entity Level** section. From the **Level** list, choose **Edge**.
- 4 Locate the **Input Entities** section. Click  **Add**.
- 5 In the **Add** dialog, in the **Selections to add** list, choose **Inlet 1 Line**, **Outlet 1 Line**, **Outlet 2 Line**, and **Inlet 2 Line**.

**6** Click **OK**.