



Model created in COMSOL Multiphysics 6.4

Maximizing the Eigenfrequency of a Beam

Introduction

Topology optimization can be used to get good ideas for the initial design of a new product. COMSOL supports topology optimization with the new density method via the **Density Model** feature in the **Topology Optimization** interface. This method assigns spatially varying material properties depending on the local value of a control variable field, and this happens automatically for structural mechanics, if you use the **Topology Link** material feature. For more details, see the [Topology Optimization of an MBB Beam](#) Application Library model.

Model Definition

This example considers a beam fixed at one end with an added mass at the other end. In this case the added mass is only 15% of the total beam weight, so the self-weight of the beam plays a large role in determining the eigenfrequency of the beam, but the added mass still has to be supported to avoid low eigenfrequencies.

The beam is made of steel, and the objective is to maximize the lowest eigenfrequency by distributing the material without violating a volume constraint.

The beam is supposed to be symmetric across the xz -plane, but the eigenmodes are not expected to respect this symmetry, so the full beam has to be modeled in every optimization iteration. A symmetric design of the beam can still be imposed using the **Mirror Symmetry** feature in the **Topology Optimization** interface.

It can be difficult to get discrete designs when maximizing the eigenfrequency using topology optimization, because the process of removing a structural member will typically introduce a low eigenfrequency for one of the intermediate designs, which can lead to grayscale. This model uses continuation of the SIMP exponent and projection slope (see [Topology Optimization of an MBB Beam](#) in the application library) using a **Parametric Sweep**. This is not necessary for the mesh size used in the model, but it is necessary if a finer mesh is used.

Results and Discussion

The optimal design is [Figure 1](#), where it can be seen that the optimization supports the added weight, but a minimal amount of material is spent far away from the supports because the extra stiffness does not justify the added mass in this region.

Eigenfrequency=41.945 Hz

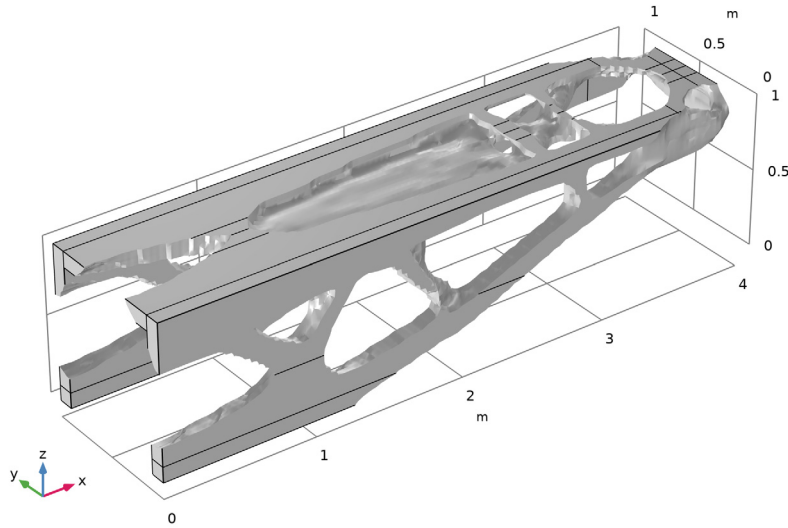

Figure 1: The default topology optimization plot shows the mass distribution of the optimized beam. Note that there is an added mass of 15% (of the beam weight) at the tip, and that the optimization is free to place material anywhere in the box.

Notes About the COMSOL Implementation

This model combines the **Topology Optimization** interface with the **Stationary Then Eigenfrequency** study step. The study step allows computing the dependent variables associated with the Helmholtz filter (for imposing a minimum length scale) in a **Stationary** solver, while the dependent variables associated with the eigenfrequency analysis of the **Solid Mechanics** interface is computed by an **Eigenvalue Solver**. The use of this study step is thus critical when gradient-based optimization is used for optimizing eigenvalues using the **Shape Optimization** and **Topology Optimization** interfaces.

Application Library path: Optimization_Module/Topology_Optimization/
beam_eigenfrequency_topology_optimization



Modeling Instructions

From the **File** menu, choose **New**.

NEW

In the **New** window, click  **Model Wizard**.

MODEL WIZARD

- 1 In the **Model Wizard** window, click  **3D**.
- 2 In the **Select Physics** tree, select **Structural Mechanics > Solid Mechanics (solid)**.
- 3 Click **Add**.
- 4 Click  **Study**.
- 5 In the **Select Study** tree, select **Empty Study**.
- 6 Click  **Done**.

GLOBAL DEFINITIONS

Parameters I

- 1 In the **Model Builder** window, expand the **Component 1 (comp1) > Definitions** node, then click **Global Definitions > Parameters I**.
- 2 In the **Settings** window for **Parameters**, locate the **Parameters** section.
- 3 In the table, enter the following settings:

Name	Expression	Value	Description
Lx	4[m]	4 m	Beam length
Lyz	1[m]	1 m	Beam width and height
L1	0.1[m]	0.1 m	Width of added mass
thk	Lyz/10	0.1 m	Thickness
meshsz	5[cm]	0.05 m	Mesh size
volfrac	0.4	0.4	Maximum volume fraction
loadFactor	0.15	0.15	Mass load factor

Name	Expression	Value	Description
Emin	1e-6	1E-6	Relative minimum Young's modulus
rhoMin	10*Emin	1E-5	Relative minimum density
pSIMP	3	3	SIMP interpolation parameter
beta	1	1	Projection slope
Rmin	2*meshsz	0.1 m	Filter radius

COMPONENT 1: OPTIMIZATION

- 1 In the **Model Builder** window, click **Component 1 (comp1)**.
- 2 In the **Settings** window for **Component**, type Component 1: Optimization in the **Label** text field.

GEOMETRY 1

Block 1 (blk1)

- 1 In the **Geometry** toolbar, click  **Block**.
- 2 In the **Settings** window for **Block**, locate the **Size and Shape** section.
- 3 In the **Width** text field, type Lx.
- 4 In the **Depth** text field, type Lyz.
- 5 In the **Height** text field, type Lyz.
- 6 Click to expand the **Layers** section. In the table, enter the following settings:

Layer name	Thickness (m)
Layer 1	thk
Layer 2	Lyz/2-2*thk

- 7 Click to expand the **Layers** section. Find the **Layer position** subsection. Select the **Front** checkbox.
- 8 Select the **Right** checkbox.
- 9 Select the **Back** checkbox.
- 10 Locate the **Selections of Resulting Entities** section. Select the **Resulting objects selection** checkbox.

Block 2 (blk2)

- 1 In the **Geometry** toolbar, click  **Block**.
- 2 In the **Settings** window for **Block**, locate the **Size and Shape** section.

- 3 In the **Width** text field, type $Lx - thk$.
- 4 In the **Depth** text field, type $Lyz - 2 * thk$.
- 5 In the **Height** text field, type $Lyz - thk$.
- 6 Locate the **Position** section. In the **y** text field, type thk .
- 7 Locate the **Selections of Resulting Entities** section. Select the **Resulting objects selection** checkbox.

Difference 1 (dif1)

- 1 In the **Geometry** toolbar, click  **Booleans and Partitions** and choose **Difference**.
- 2 In the **Settings** window for **Difference**, locate the **Difference** section.
- 3 From the **Objects to add** list, choose **Block 1**.
- 4 From the **Objects to subtract** list, choose **Block 2**.

Work Plane 1 (wp1)

- 1 In the **Geometry** toolbar, click  **Work Plane**.
- 2 In the **Settings** window for **Work Plane**, locate the **Plane Definition** section.
- 3 From the **Plane** list, choose **zx-plane**.
- 4 In the **y-coordinate** text field, type $Lyz / 2$.

Partition Objects 1 (par1)

- 1 In the **Geometry** toolbar, click  **Booleans and Partitions** and choose **Partition Objects**.
- 2 In the **Settings** window for **Partition Objects**, locate the **Partition Objects** section.
- 3 From the **Objects to partition** list, choose **Block 1**.
- 4 From the **Partition with** list, choose **Work plane**.

Fixed Boundaries

- 1 In the **Geometry** toolbar, click  **Selections** and choose **Box Selection**.
- 2 In the **Settings** window for **Box Selection**, type **Fixed Boundaries** in the **Label** text field.
- 3 Locate the **Geometric Entity Level** section. From the **Level** list, choose **Boundary**.
- 4 Locate the **Box Limits** section. In the **x maximum** text field, type $0.001 * Lx$.
- 5 Locate the **Output Entities** section. From the **Include entity if** list, choose **Entity inside box**.

Load Boundary



- 1 In the **Geometry** toolbar, click  **Selections** and choose **Box Selection**.
- 2 In the **Settings** window for **Box Selection**, type **Load Boundary** in the **Label** text field.

- 3 Locate the **Geometric Entity Level** section. From the **Level** list, choose **Boundary**.
- 4 Locate the **Box Limits** section. In the **x minimum** text field, type $Lx - 1.001 * thk$.
- 5 In the **y minimum** text field, type $Lyz / 2 - thk * 1.001$.
- 6 In the **y maximum** text field, type $Lyz / 2 + thk * 1.001$.
- 7 In the **z minimum** text field, type $0.999 * Lyz$.
- 8 Locate the **Output Entities** section. From the **Include entity if** list, choose **Entity inside box**.



Design Domain

- 1 In the **Geometry** toolbar, click  **Selections** and choose **Box Selection**.
- 2 In the **Settings** window for **Box Selection**, type **Design Domain** in the **Label** text field.
- 3 Locate the **Box Limits** section. In the **y maximum** text field, type $Lyz / 1.999$.
- 4 Locate the **Output Entities** section. From the **Include entity if** list, choose **Entity inside box**.

Mirror Domain

- 1 In the **Geometry** toolbar, click  **Selections** and choose **Complement Selection**.
- 2 In the **Settings** window for **Complement Selection**, type **Mirror Domain** in the **Label** text field.
- 3 Locate the **Input Entities** section. Click  **Add**.
- 4 In the **Add** dialog, select **Design Domain** in the **Selections to invert** list.
- 5 Click **OK**.

ADD MATERIAL

- 1 In the **Materials** toolbar, click  **Add Material** to open the **Add Material** window.
- 2 Go to the **Add Material** window.
- 3 In the tree, select **Built-in > Structural steel**.
- 4 Click the **Add to Global Materials** button in the window toolbar.
- 5 In the **Materials** toolbar, click  **Add Material** to close the **Add Material** window.

COMPONENT 1: OPTIMIZATION (COMPI)

Density Model 1 (dtopo1)

- 1 In the **Physics** toolbar, click  **Optimization** and choose **Topology Optimization**.
- 2 In the **Settings** window for **Density Model**, locate the **Geometric Entity Selection** section.
- 3 From the **Selection** list, choose **Design Domain**.

- 4 Locate the **Filtering** section. From the R_{\min} list, choose **User defined**.
- 5 In the text field, type `Rmin`.
- 6 Locate the **Projection** section. From the **Projection type** list, choose **Hyperbolic tangent projection**.
- 7 In the β text field, type `beta`.
- 8 Locate the **Interpolation** section. From the p_{SIMP} list, choose **User defined**.
- 9 In the text field, type `pSIMP`.
- 10 Locate the **Control Variable Discretization** section. From the **Element order** list, choose **Constant**.
- 11 Locate the **Control Variable Initial Value** section. In the θ_0 text field, type `volfrac`.

The eigenmodes are not symmetric, so the entire beam has to be modeled in every optimization iteration, but a symmetric design can be enforced using the **Mirror Symmetry** feature.

Mirror Symmetry 1

- 1 In the **Topology Optimization** toolbar, click  **Mirror Symmetry**.
- 2 In the **Settings** window for **Mirror Symmetry**, locate the **Geometric Entity Selection** section.
- 3 From the **Selection** list, choose **Mirror Domain**.

MATERIALS

Topology Link 1 (toplnk1)

- 1 In the **Model Builder** window, under **Component 1: Optimization (comp1)** right-click **Materials** and choose **More Materials > Topology Link**.
- 2 In the **Settings** window for **Topology Link**, locate the **Link Settings** section.
- 3 From the **Topology source** list, choose **Density Model 1 (dtopo1)**.

SOLID MECHANICS (SOLID)

When doing topology optimization, the representation of the geometry is not sufficiently accurate to warrant second order discretization.

- 1 In the **Model Builder** window, under **Component 1: Optimization (comp1)** click **Solid Mechanics (solid)**.
- 2 In the **Settings** window for **Solid Mechanics**, click to expand the **Discretization** section.
- 3 From the **Displacement field** list, choose **Linear**.

Fixed Constraint 1

- 1 In the **Physics** toolbar, click  **Boundaries** and choose **Fixed Constraint**.
- 2 In the **Settings** window for **Fixed Constraint**, locate the **Boundary Selection** section.
- 3 From the **Selection** list, choose **Fixed Boundaries**.

Added Mass 1

- 1 In the **Physics** toolbar, click  **Boundaries** and choose **Added Mass**.
- 2 In the **Settings** window for **Added Mass**, locate the **Boundary Selection** section.
- 3 From the **Selection** list, choose **Load Boundary**.
- 4 Locate the **Added Mass** section. From the **Mass type** list, choose **Total mass**.
- 5 In the m text field, type $\text{mat1.def.rho} * (\text{Lx} * \text{Lyz}^2 - (\text{Lx} - \text{thk}) * (\text{Lyz} - \text{thk}) * (\text{Lyz} - 2 * \text{thk})) * \text{volfrac} * \text{loadFactor}$.

MESH 1

Mapped 1

- 1 In the **Mesh** toolbar, click  **More Generators** and choose **Mapped**.
- 2 In the **Settings** window for **Mapped**, locate the **Boundary Selection** section.
- 3 From the **Selection** list, choose **Fixed Boundaries**.

Size

- 1 In the **Model Builder** window, click **Size**.
- 2 In the **Settings** window for **Size**, click to expand the **Element Size Parameters** section.
- 3 In the **Maximum element size** text field, type meshsz .
- 4 In the **Minimum element size** text field, type $\text{meshsz}/2$.

Swept 1

- 1 In the **Mesh** toolbar, click  **Swept**.
- 2 In the **Settings** window for **Swept**, click  **Build All**.

STUDY 1

The Helmholtz filter in the **Density Model** feature requires a **Stationary** solver, whereas the computation of the eigenfrequency requires an **Eigenvalue Solver**.

Step 1: Stationary Then Eigenfrequency

In the **Study** toolbar, click  **More Study Steps** and choose **Eigenfrequency** > **Stationary Then Eigenfrequency**.

Topology Optimization

- 1 In the **Study** toolbar, click  **Optimization** and choose **Topology Optimization**.
- 2 In the **Settings** window for **Topology Optimization**, locate the **Optimization Solver** section.
- 3 From the **Method** list, choose **MMA**.
- 4 In the **Maximum number of iterations** text field, type 50.
- 5 Select the **Move limits** checkbox. In the associated text field, type 0.1.
- 6 Locate the **Objective Function** section. In the table, enter the following settings:

Expression	Description
real(freq)	

- 7 From the **Type** list, choose **Maximization**.
- 8 From the **Solution** list, choose **Minimum of objectives** to set up a maximin optimization problem.
- 9 Find the **Objective settings** subsection. From the **Objective scaling** list, choose **Initial solution based**.
- 10 Click **Add Expression** in the upper-right corner of the **Constraints** section. From the menu, choose **Component 1: Optimization (comp1) > Definitions > Density Model 1 > Global > comp1.dtopo1.theta_avg - Average material volume factor - 1**.
- 11 Locate the **Constraints** section. In the table, enter the following settings:

Expression	Lower bound	Upper bound
comp1.dtopo1.theta_avg		volfrac

- 12 In the **Model Builder** window, click **Study 1**.
- 13 In the **Settings** window for **Study**, type Study 1 - Optimization in the **Label** text field.
- 14 In the **Study** toolbar, click  **Get Initial Value**.

It can be difficult to avoid a bad local optimum, but the situation can be improved by using a **Parametric Sweep**, to perform continuation in the projection slope, and SIMP penalization parameters.

Parametric Sweep

- 1 In the **Study** toolbar, click  **Parametric Sweep**.
- 2 In the **Settings** window for **Parametric Sweep**, locate the **Study Settings** section.
- 3 Click **+** **Add** twice.

4 In the table, enter the following settings:

Parameter name	Parameter value list	Parameter unit
pSIMP (SIMP interpolation parameter)	1 2 3 4 5	
beta (Projection slope)	2 4 8 16 32	

5 Click to expand the **Advanced Settings** section. Select the **Reuse solution from previous step** checkbox.

Topology Optimization



- 1 In the **Model Builder** window, click **Topology Optimization**.
- 2 In the **Settings** window for **Topology Optimization**, click to expand the **Output** section.
- 3 Select the **Plot** checkbox.
- 4 In the table, enter the following settings:

Plot group	Plot window
Threshold	Graphics

5 In the **Study** toolbar, click  **Compute**.

RESULTS

Threshold

- 1 In the **Model Builder** window, expand the **Topology Optimization** node, then click **Threshold**.
- 2 In the **Threshold** toolbar, click  **Plot**.
- 3 Click the  **Zoom Extents** button in the **Graphics** toolbar.

Notice that the optimization causes identical values for the two lowest eigenfrequencies.

Topology Optimization - Parametric

- 1 In the **Model Builder** window, under **Results** click **Topology Optimization 1**.
- 2 In the **Settings** window for **Group**, type Topology Optimization - Parametric in the **Label** text field.

Perform verification on a body-fitted mesh in a new component. Start by solving the Helmholtz filter on a finer mesh.

MESH 1



In the **Model Builder** window, under **Component 1: Optimization (comp1)** right-click **Mesh 1** and choose **Duplicate**.

MESH 2

Size

- 1 In the **Model Builder** window, expand the **Mesh 2** node, then click **Size**.
- 2 In the **Settings** window for **Size**, locate the **Element Size Parameters** section.
- 3 In the **Maximum element size** text field, type $\text{meshsz}/2$.
- 4 In the **Minimum element size** text field, type $\text{meshsz}/4$.

ADD STUDY

- 1 In the **Home** toolbar, click  **Add Study** to open the **Add Study** window.
- 2 Go to the **Add Study** window.
- 3 Find the **Physics interfaces in study** subsection. In the table, clear the **Solve** checkbox for **Solid Mechanics (solid)**.
- 4 Find the **Studies** subsection. In the **Select Study** tree, select **Preset Studies for Selected Physics Interfaces > Stationary**.
- 5 Click the **Add Study** button in the window toolbar.
- 6 In the **Home** toolbar, click  **Add Study** to close the **Add Study** window.

STUDY 2

Step 1: Stationary

- 1 In the **Settings** window for **Stationary**, click to expand the **Values of Dependent Variables** section.
- 2 Find the **Initial values of variables solved for** subsection. From the **Settings** list, choose **User controlled**.
- 3 From the **Method** list, choose **Solution**.
- 4 From the **Study** list, choose **Study 1 - Optimization, Stationary Then Eigenfrequency**.
- 5 In the **Model Builder** window, click **Study 2**.
- 6 In the **Settings** window for **Study**, locate the **Study Settings** section.
- 7 Clear the **Generate default plots** checkbox.
- 8 In the **Label** text field, type **Study 2 - Smooth Design (mesh2)**.
- 9 In the **Study** toolbar, click  **Compute**.

RESULTS

Filter

- 1 In the **Model Builder** window, expand the **Results > Datasets** node, then click **Filter**.
- 2 In the **Settings** window for **Filter**, locate the **Data** section.
- 3 From the **Dataset** list, choose **Study 2 - Smooth Design (mesh2)/Solution 8 (sol8)**.
- 4 Locate the **Expression** section. In the **Expression** text field, type `dtopo1.theta_f`.
- 5 Right-click **Results > Datasets > Filter** and choose **Create Mesh-Based Geometry**.

COMPONENT 2: VERIFICATION



In the **Settings** window for **Component**, type **Component 2: Verification** in the **Label** text field.

MESH-BASED GEOMETRY I

Import 2

In the **Model Builder** window, under **Component 2: Verification (comp2) > Mesh-Based Geometry I** right-click **Import I** and choose **Duplicate**.

Transform 1

- 1 In the **Mesh** toolbar, click  **More Attributes** and choose **Transform**.
- 2 In the **Settings** window for **Transform**, locate the **Displacement** section.
- 3 In the **y** text field, type `Lyz`.
- 4 Locate the **Scale** section. From the **Scaling** list, choose **Anisotropic**.
- 5 In the **y scale** text field, type `-1`.
- 6 Click  **Build Selected**.

Remesh Faces 1

In the **Mesh** toolbar, click  **More Generators** and choose **Remesh Faces**.

Size

- 1 In the **Model Builder** window, expand the **Remesh Faces 1** node, then click **Size**.
- 2 In the **Settings** window for **Size**, click to expand the **Element Size Parameters** section.
- 3 In the **Maximum element size** text field, type `meshsz`.
- 4 In the **Minimum element size** text field, type `meshsz/2`.

Remesh Faces 1

- 1 In the **Model Builder** window, click **Remesh Faces 1**.

- 2 In the **Settings** window for **Remesh Faces**, locate the **Boundary Selection** section.
- 3 From the **Selection** list, choose **Filter**.

Remesh Faces 2

- 1 Right-click **Component 2: Verification (comp2) > Mesh-Based Geometry 1 > Remesh Faces 1** and choose **Duplicate**.
- 2 In the **Settings** window for **Remesh Faces**, locate the **Boundary Selection** section.
- 3 Click to select the  **Activate Selection** toggle button.
- 4 From the **Selection** list, choose **Filter(1)**.

Size

- 1 In the **Model Builder** window, expand the **Remesh Faces 2** node, then click **Size**.
- 2 In the **Settings** window for **Size**, click to expand the **Element Size Parameters** section.
- 3 In the **Maximum element size** text field, type meshsz.
- 4 In the **Minimum element size** text field, type meshsz/2.
- 5 Click  **Build Selected**.

Union 1

In the **Mesh** toolbar, click  **Booleans and Partitions** and choose **Union**.

Finalize

In the **Model Builder** window, right-click **Finalize** and choose **Build Selected**.

COMPONENT 1: OPTIMIZATION (COMP1)

In the **Model Builder** window, expand the **Component 1: Optimization (comp1)** node.

MATERIALS

Material Link 1 (matLnk1)

- 1 In the **Model Builder** window, expand the **Component 1: Optimization (comp1) > Materials** node.
- 2 Right-click **Component 2: Verification (comp2) > Materials** and choose **More Materials > Material Link**.

SOLID MECHANICS (SOLID)

In the **Model Builder** window, under **Component 1: Optimization (comp1)** right-click **Solid Mechanics (solid)** and choose **Copy**.

SOLID MECHANICS (SOLID2)

- 1 In the **Model Builder** window, right-click **Component 2: Verification (comp2)** and choose **Paste Solid Mechanics**.
- 2 In the **Messages from Paste** dialog, click **OK**.

Fixed Constraint 1

- 1 In the **Model Builder** window, expand the **Solid Mechanics (solid2)** node, then click **Fixed Constraint 1**.
- 2 In the **Settings** window for **Fixed Constraint**, locate the **Boundary Selection** section.
- 3 From the **Selection** list, choose **Fixed Boundaries**.

Fixed Constraint 2

- 1 Right-click **Component 2: Verification (comp2) > Solid Mechanics (solid2) > Fixed Constraint 1** and choose **Duplicate**.
- 2 In the **Settings** window for **Fixed Constraint**, locate the **Boundary Selection** section.
- 3 From the **Selection** list, choose **Fixed Boundaries(1)**.

Added Mass 1

- 1 In the **Model Builder** window, click **Added Mass 1**.
- 2 In the **Settings** window for **Added Mass**, locate the **Boundary Selection** section.
- 3 From the **Selection** list, choose **Load Boundary**.
- 4 Locate the **Added Mass** section. In the m text field, type $0.5 * \text{mat1.def.rho} * (\text{Lx} * \text{Lyz}^2 - (\text{Lx} - \text{thk}) * (\text{Lyz} - \text{thk}) * (\text{Lyz} - 2 * \text{thk})) * \text{volfrac} * \text{loadFactor}$.

Added Mass 2

- 1 Right-click **Component 2: Verification (comp2) > Solid Mechanics (solid2) > Added Mass 1** and choose **Duplicate**.
- 2 In the **Settings** window for **Added Mass**, locate the **Boundary Selection** section.
- 3 From the **Selection** list, choose **Load Boundary(1)**.

ADD STUDY

- 1 In the **Home** toolbar, click  **Add Study** to open the **Add Study** window.
- 2 Go to the **Add Study** window.
- 3 Find the **Physics interfaces in study** subsection. In the table, clear the **Solve** checkbox for **Solid Mechanics (solid)**.
- 4 Find the **Studies** subsection. In the **Select Study** tree, select **General Studies > Eigenfrequency**.

- 5 Click the **Add Study** button in the window toolbar.
- 6 In the **Home** toolbar, click  **Add Study** to close the **Add Study** window.

STUDY 1 - OPTIMIZATION

Step 1: Stationary Then Eigenfrequency

- 1 In the **Settings** window for **Stationary Then Eigenfrequency**, locate the **Physics and Variables Selection** section.
- 2 In the **Solve for** column of the table, under **Component 2: Verification (comp2)**, clear the checkbox for **Solid Mechanics (solid2)**.

STUDY 2 - SMOOTH DESIGN (MESH2)

Step 1: Stationary

- 1 In the **Model Builder** window, under **Study 2 - Smooth Design (mesh2)** click **Step 1: Stationary**.
- 2 In the **Settings** window for **Stationary**, locate the **Physics and Variables Selection** section.
- 3 In the **Solve for** column of the table, under **Component 2: Verification (comp2)**, clear the checkbox for **Solid Mechanics (solid2)**.

STUDY 3

Step 1: Eigenfrequency

- 1 In the **Model Builder** window, under **Study 3** click **Step 1: Eigenfrequency**.
- 2 In the **Settings** window for **Eigenfrequency**, locate the **Physics and Variables Selection** section.
- 3 In the **Solve for** column of the table, under **Component 1: Optimization (comp1)**, clear the checkbox for **Topology Optimization**.

MESH 3

Free Tetrahedral 1

In the **Mesh** toolbar, click  **Free Tetrahedral**.

Size

- 1 In the **Model Builder** window, click **Size**.
- 2 In the **Settings** window for **Size**, click to expand the **Element Size Parameters** section.
- 3 In the **Maximum element size** text field, type meshsz.
- 4 In the **Minimum element size** text field, type meshsz/2.

5 Click  **Build All**.

STUDY 3 - VERIFICATION

- 1 In the **Model Builder** window, click **Study 3**.
- 2 In the **Settings** window for **Study**, type Study 3 - Verification in the **Label** text field.
- 3 In the **Home** toolbar, click  **Compute**.

RESULTS

Topology Optimization 1

In the **Model Builder** window, under **Results** right-click **Topology Optimization 1** and choose **Delete**.

Verification

- 1 In the **Model Builder** window, under **Results** click **Mode Shape (solid2)**.
- 2 In the **Settings** window for **3D Plot Group**, type Verification in the **Label** text field.
Notice how the eigenfrequencies are higher relative to the raw optimization result.

Verification

- 1 In the **Results** toolbar, click  **Evaluation Group**.
- 2 In the **Settings** window for **Evaluation Group**, type Verification in the **Label** text field.

Global Evaluation 1

- 1 Right-click **Verification** and choose **Global Evaluation**.
- 2 In the **Settings** window for **Global Evaluation**, click **Add Expression** in the upper-right corner of the **Expressions** section. From the menu, choose **Component 1: Optimization (comp1) > Definitions > Density Model 1 > Global > dtopol.theta_avg - Average material volume factor - 1**.

Volume Integration 1

- 1 In the **Model Builder** window, right-click **Verification** and choose **Integration > Volume Integration**.
- 2 In the **Settings** window for **Volume Integration**, locate the **Data** section.
- 3 From the **Dataset** list, choose **Study 3 - Verification/Solution 9 (5) (sol9)**.
- 4 Locate the **Selection** section. From the **Selection** list, choose **All domains**.

5 Locate the **Expressions** section. In the table, enter the following settings:

Expression	Unit	Description
$1 / (Lx * Lyz^2 - (Lx - thk) * (Lyz - thk) * (Lyz - 2 * thk))$	1	Volume fraction

6 In the **Verification** toolbar, click  **Evaluate**.

Notice how the eigenfrequencies are higher with the body-fitted mesh relative to the raw optimization result. This is due to the removal of the soft material near the boundary.