



Model created in COMSOL Multiphysics 6.4

Snap Hook

Introduction

This model simulates the insertion of a snap hook in its slot. Fasteners like this are common in the automotive industry, for example, in the control panel of a car. In this case it is important to know the force that must be applied in order to place the hook in the slot, but also the force needed to remove it. From a numerical point of view, this is a highly nonlinear structural analysis, mainly due to the contact interaction between the hook and the slot, but also due to the elastoplastic constitutive law selected for the hook, and finally due to the geometrical nonlinearity originating from the large displacements.

Model Definition

Due to symmetry, you can study only half of the original snap hook geometry, this way reducing the size of the model. [Figure 1](#) shows the modeled geometry.

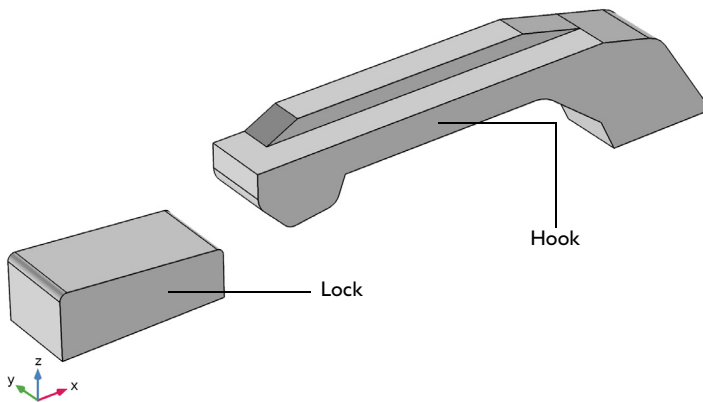

Figure 1: Geometry of the modeled snap hook and locking mechanism.

MATERIAL PROPERTIES

For the hook, assume an elastoplastic material model with isotropic hardening and a constant tangent hardening modulus, with material properties according to the following table.

MATERIAL PARAMETER	VALUE
Young's modulus	10 GPa
Poisson's number	0.35
Yield stress	120 MPa
Isotropic tangent modulus	1.2 GPa

The lock is assumed to be rigid and therefore do not require any physics nor material properties.

BOUNDARY CONDITIONS

- The locking mechanism is considered as rigid, and is modeled as a meshed surface without any physics defined.
- A prescribed displacement boundary condition is applied at the rightmost bottom surface of the hook. The displacement in the x direction is gradually changed by using the parametric solver; the other two displacement components are zero.
- A symmetry condition is applied on a boundary aligned with the xy -plane
- All the other boundaries are free boundaries. However, several of them are selected as parts of a contact pair with the destination side being on the hook surface.
- Contact between the hook and the lock is modeled using a penalty formulation. A Coulomb friction model is applied for the tangential behavior.

Results

The maximum von Mises stress levels are found when the parameter step is about 0.66, that is, just before the hook enters the slot, see [Figure 2](#).

The force required for the insertion and removal of the fastener is shown in [Figure 3](#) as function of the displacement. Distinct peaks are clearly visible that coincide with the instances that the hook comes into and loses contact with the lock.

The insertion of the hook causes it to become permanently deformed. As you can see in [Figure 4](#), after the hook has been removed there is a region where the plastic strains are greater than zero. This means that the hook has not returned to its original shape

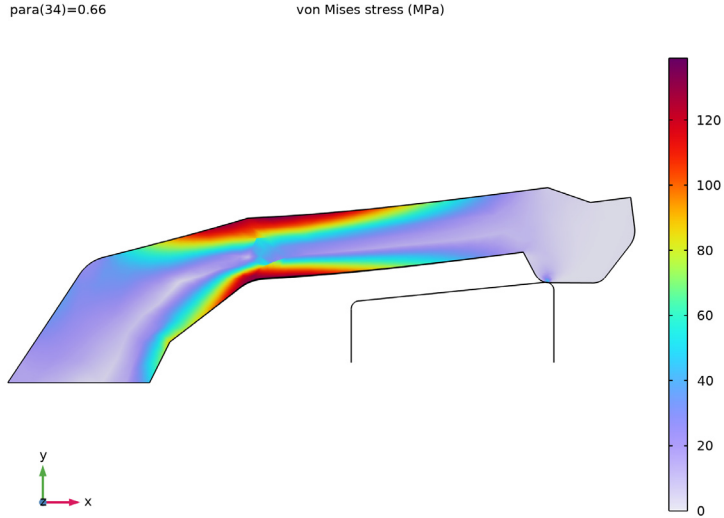

Figure 2: Distribution of von Mises stress in the hook just before it enters the slot.

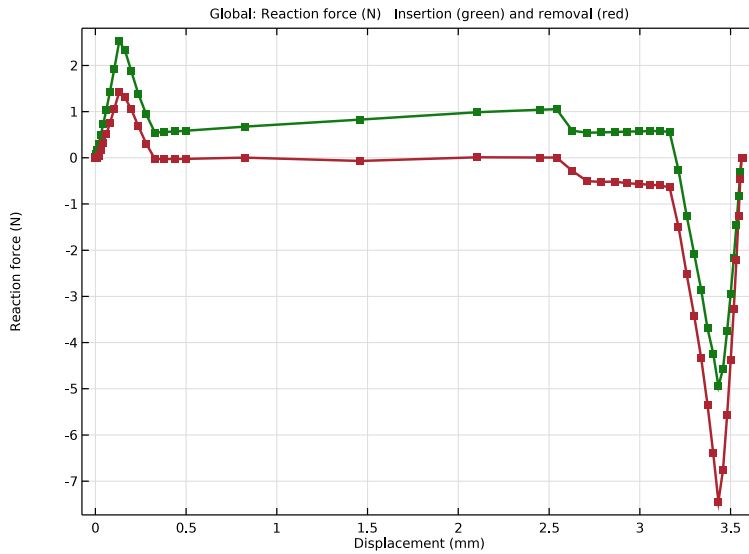

Figure 3: The mounting force as a function of displacement.

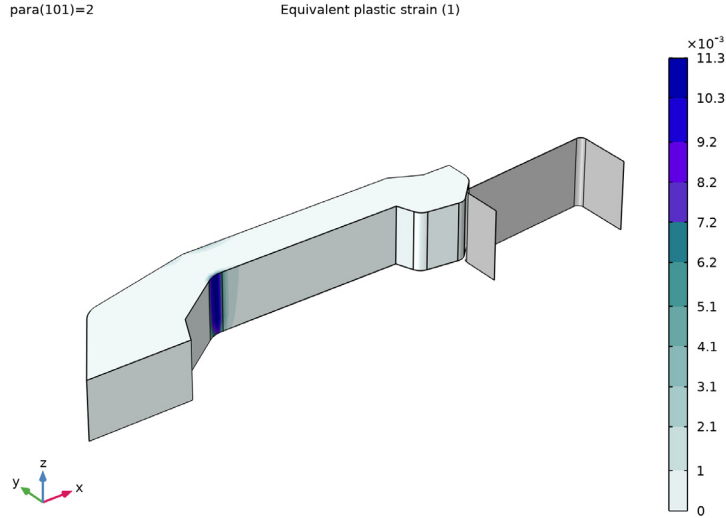



Figure 4: Equivalent plastic strain in the hook after its removal from the slot.

Application Library path: Nonlinear_Structural_Materials_Module/
Plasticity/snap_hook



Modeling Instructions

From the **File** menu, choose **New**.

NEW

In the **New** window, click  **Model Wizard**.

MODEL WIZARD

- 1 In the **Model Wizard** window, click  **3D**.
- 2 In the **Select Physics** tree, select **Structural Mechanics > Solid Mechanics (solid)**.
- 3 Click **Add**.
- 4 Click  **Study**.

- 5 In the **Select Study** tree, select **General Studies > Stationary**.
- 6 Click  **Done**.

GEOMETRY I

Import I (impI)

- 1 In the **Geometry** toolbar, click  **Import**.
- 2 In the **Settings** window for **Import**, locate the **Source** section.
- 3 Click  **Browse**.
- 4 Browse to the model's Application Libraries folder and double-click the file `snap_hook.mphbin`.
- 5 Click  **Import**.

Partition Domains I (pardI)



- 1 In the **Geometry** toolbar, click  **Booleans and Partitions** and choose **Partition Domains**.
- 2 On the object **impI(2)**, select Domain 1 only.
- 3 In the **Settings** window for **Partition Domains**, locate the **Partition Domains** section.
- 4 From the **Partition with** list, choose **Extended faces**.
- 5 On the object **impI(2)**, select Boundary 11 only.

It might be easier to select the correct boundary by using the **Selection List** window. To open this window, in the **Home** toolbar click **Windows** and choose **Selection List**. (If you are running the cross-platform desktop, you find **Windows** in the main menu.)

Form Union (fin)

- 1 In the **Model Builder** window, under **Component 1 (comp1) > Geometry 1** click **Form Union (fin)**.
- 2 In the **Settings** window for **Form Union/Assembly**, locate the **Form Union/Assembly** section.
- 3 From the **Action** list, choose **Form an assembly**.
- 4 Clear the **Create pairs** checkbox.

Mesh Control Domains I (mcdI)

- 1 In the **Geometry** toolbar, click  **Virtual Operations** and choose **Mesh Control Domains**.
- 2 On the object **fin**, select Domains 1–3 only.
- 3 In the **Settings** window for **Mesh Control Domains**, click  **Build Selected**.
- 4 Click the  **Zoom Extents** button in the **Graphics** toolbar.

- 5 Click the  **Show Grid** button in the **Graphics** toolbar.

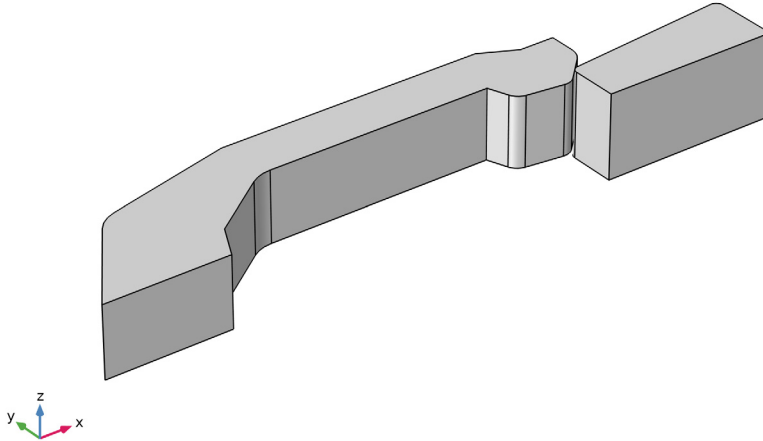

SOLID MECHANICS (SOLID)

- 1 In the **Model Builder** window, under **Component 1 (comp1)** click **Solid Mechanics (solid)**.
- 2 In the **Settings** window for **Solid Mechanics**, locate the **Domain Selection** section.
- 3 From the **Selection** list, choose **Manual**.
- 4 Select Domain 1 only.

Before adding the material for the hook, specify the plasticity model. This way, you can see which material parameters are required.

Linear Elastic Material 1

In the **Model Builder** window, under **Component 1 (comp1)** > **Solid Mechanics (solid)** click **Linear Elastic Material 1**.

Plasticity 1

- 1 In the **Physics** toolbar, click  **Attributes** and choose **Plasticity**.
- 2 In the **Settings** window for **Plasticity**, locate the **Domain Selection** section.
- 3 In the list box, select **2 (not applicable)**.
- 4 Select Domain 1 only.

MATERIALS

Material 1 (mat1)

- 1 In the **Model Builder** window, under **Component 1 (comp1)** right-click **Materials** and choose **Blank Material**.
- 2 In the **Settings** window for **Material**, locate the **Geometric Entity Selection** section.
- 3 In the list box, select **2**.
- 4 Select Domain 1 only.
- 5 Locate the **Material Contents** section. In the table, enter the following settings:

Property	Variable	Value	Unit	Property group
Young's modulus	E	10 [GPa]	Pa	Young's modulus and Poisson's ratio
Poisson's ratio	nu	0.35	1	Young's modulus and Poisson's ratio
Density	rho	7850 [kg/m ³]	kg/m ³	Basic

DEFINITIONS

Increase the initial yield stress near the contact surface to avoid spurious plastic deformations that might occur due to the computational errors during iterations in the contact force calculations. To implement this, first define a step function that smoothly drops from 1000 to 1 near the hook tip. Then use the step function as a multiplier for the yield stress.

Step 1 (step1)

- 1 In the **Definitions** toolbar, click  **More Functions** and choose **Step**.
- 2 In the **Settings** window for **Step**, locate the **Parameters** section.
- 3 In the **Location** text field, type 1.5 [mm].
- 4 In the **From** text field, type 1e3.
- 5 Click to expand the **Smoothing** section. In the **Size of transition zone** text field, type 1e-3.

Set the yield stress of the material definition and multiply it with the step function. Use negative X material coordinate as an argument since it increases along the length of the hook.

MATERIALS

Material 1 (mat1)

- 1 In the **Model Builder** window, under **Component 1 (comp1) > Materials** click **Material 1 (mat1)**.
- 2 In the **Settings** window for **Material**, locate the **Material Contents** section.
- 3 In the table, enter the following settings:

Property	Variable	Value	Unit	Property group
Initial yield stress	sigmags	120[MPa]* step1(-X)	Pa	Elastoplastic material model
Isotropic tangent modulus	Et	1.2[GPa]	Pa	Elastoplastic material model

DEFINITIONS



Source

- 1 In the **Definitions** toolbar, click  **Explicit**.
- 2 In the **Settings** window for **Explicit**, type Source in the **Label** text field.
- 3 Locate the **Input Entities** section. From the **Geometric entity level** list, choose **Boundary**.
- 4 Select the **Group by continuous tangent** checkbox.
- 5 Select Boundaries 22 and 26–29 only.

Destination

- 1 In the **Definitions** toolbar, click  **Explicit**.
- 2 In the **Settings** window for **Explicit**, type Destination in the **Label** text field.
- 3 Locate the **Input Entities** section. From the **Geometric entity level** list, choose **Boundary**.
- 4 Select Boundaries 14–16, 18, and 19 only.

Contact Pair 1 (p1)

- 1 In the **Definitions** toolbar, click  **Pairs** and choose **Contact Pair**.
- 2 In the **Settings** window for **Pair**, locate the **Source Boundaries** section.
- 3 From the **Selection** list, choose **Source**.
- 4 Locate the **Destination Boundaries** section. Click to select the  **Activate Selection** toggle button.
- 5 From the **Selection** list, choose **Destination**.

GLOBAL DEFINITIONS



Parameters 1

- 1 In the **Model Builder** window, under **Global Definitions** click **Parameters 1**.
- 2 In the **Settings** window for **Parameters**, locate the **Parameters** section.
- 3 In the table, enter the following settings:

Name	Expression	Value	Description
para	0	0	Continuation parameter

DEFINITIONS

Displacement

- 1 In the **Definitions** toolbar, click  **Interpolation**.
- 2 In the **Settings** window for **Interpolation**, type Displacement in the **Label** text field.
- 3 Locate the **Definition** section. From the **Data source** list, choose **File**.
- 4 Click  **Browse**.
- 5 Browse to the model's Application Libraries folder and double-click the file snap_hook_disp.txt.
- 6 Click  **Import**.
- 7 In the **Function name** text field, type disp.
- 8 Locate the **Interpolation and Extrapolation** section. From the **Interpolation** list, choose **Piecewise cubic**.
- 9 Locate the **Units** section. In the **Argument** table, enter the following settings:

Argument	Unit
t	1

- 10 In the **Function** table, enter the following settings:

Function	Unit
disp	mm

SOLID MECHANICS (SOLID)

Prescribed Displacement 1

- 1 In the **Physics** toolbar, click  **Boundaries** and choose **Prescribed Displacement**.
- 2 Select Boundary 2 only.

- 3 In the **Settings** window for **Prescribed Displacement**, locate the **Prescribed Displacement** section.
- 4 From the **Displacement in x direction** list, choose **Prescribed**.
- 5 From the **Displacement in y direction** list, choose **Prescribed**.
- 6 From the **Displacement in z direction** list, choose **Prescribed**.
- 7 In the u_{0x} text field, type `disp(para)`.

Contact 1

In the **Model Builder** window, click **Contact 1**.

Friction 1

- 1 In the **Physics** toolbar, click  **Attributes** and choose **Friction**.
- 2 In the **Settings** window for **Friction**, locate the **Friction Parameters** section.
- 3 In the μ text field, type 0.1.

Symmetry 1

- 1 In the **Physics** toolbar, click  **Boundaries** and choose **Symmetry**.
- 2 Select Boundary 4 only.

Now create the mesh, start by defining a refined mesh in the contact region and where plastic strains are expected.

MESH 1

Edge 1

- 1 In the **Mesh** toolbar, click  **More Generators** and choose **Edge**.

- 2 Select Edges 24, 33, 36, 39, 45, and 50 only.

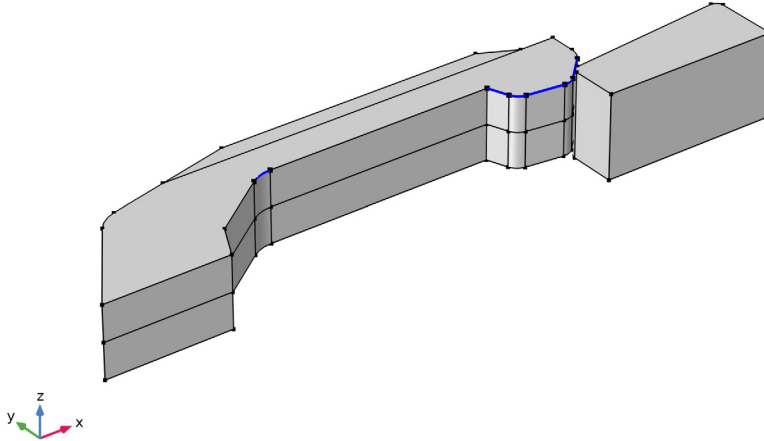

Size 1

- 1 Right-click **Edge 1** and choose **Size**.
- 2 In the **Settings** window for **Size**, locate the **Element Size** section.
- 3 Click the **Custom** button.
- 4 Locate the **Element Size Parameters** section.
- 5 Select the **Maximum element size** checkbox. In the associated text field, type $4e-5$.
- 6 Select the **Minimum element size** checkbox. In the associated text field, type $1E-5$.
- 7 Select the **Curvature factor** checkbox. In the associated text field, type 0.2 .

Size

- 1 In the **Model Builder** window, under **Component 1 (comp1) > Mesh 1** click **Size**.
- 2 In the **Settings** window for **Size**, locate the **Element Size** section.
- 3 Click the **Custom** button.
- 4 Locate the **Element Size Parameters** section. In the **Maximum element size** text field, type $3E-4$.
- 5 In the **Minimum element size** text field, type $1e-4$.
- 6 In the **Maximum element growth rate** text field, type 3 .

7 In the **Curvature factor** text field, type 0.3.

Swept 1

- 1 In the **Mesh** toolbar, click  **Swept**.
- 2 In the **Settings** window for **Swept**, locate the **Domain Selection** section.
- 3 From the **Geometric entity level** list, choose **Domain**.
- 4 Select Domains 1, 3, and 4 only.

Mapped 1

Add a surface mesh for the lock. Notice that no mesh is needed for the domain.

- 1 In the **Mesh** toolbar, click  **More Generators** and choose **Mapped**.
- 2 In the **Settings** window for **Mapped**, locate the **Boundary Selection** section.
- 3 From the **Selection** list, choose **Source**.

Size 1

- 1 Right-click **Mapped 1** and choose **Size**.
- 2 In the **Settings** window for **Size**, locate the **Element Size** section.
- 3 From the **Predefined** list, choose **Extremely coarse**.

Distribution 1

- 1 In the **Model Builder** window, right-click **Mapped 1** and choose **Distribution**.
- 2 Select Edges 65 and 71 only.
- 3 In the **Settings** window for **Distribution**, click  **Build All**.

- 4 Click the  **Zoom Extents** button in the **Graphics** toolbar.

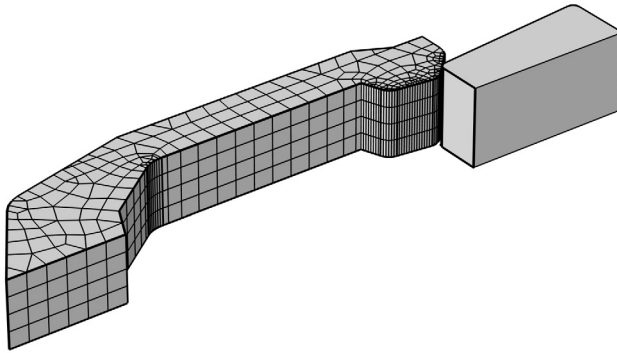

STUDY I

Step 1: Stationary

- 1 In the **Model Builder** window, under **Study I** click **Step 1: Stationary**.
- 2 In the **Settings** window for **Stationary**, click to expand the **Results While Solving** section.
- 3 Select the **Plot** checkbox.
Set up an auxiliary continuation sweep for the para parameter.
- 4 Click to expand the **Study Extensions** section. Select the **Auxiliary sweep** checkbox.
- 5 Click **+ Add**.
- 6 In the table, enter the following settings:

Parameter name	Parameter value list	Parameter unit
para (Continuation parameter)	range(0, 2e-2, 2)	

- 7 In the **Study** toolbar, click **= Compute**.

RESULTS

Stress (solid)

- 1 In the **Settings** window for **3D Plot Group**, locate the **Data** section.
- 2 From the **Parameter value (para)** list, choose **0.66**.

Volume 1

- 1 In the **Model Builder** window, expand the **Stress (solid)** node, then click **Volume 1**.
- 2 In the **Settings** window for **Volume**, locate the **Expression** section.
- 3 From the **Unit** list, choose **MPa**.

Stress (solid)

Add surface plot of the lock. You can write an arbitrary value in the expression field since a uniform color is used.

Surface 1



- 1 In the **Model Builder** window, right-click **Stress (solid)** and choose **Surface**.
- 2 In the **Settings** window for **Surface**, locate the **Expression** section.
- 3 In the **Expression** text field, type 1.
- 4 Click to expand the **Title** section. From the **Title type** list, choose **None**.
- 5 Click to collapse the **Title** section. Locate the **Coloring and Style** section. From the **Coloring** list, choose **Uniform**.
- 6 From the **Color** list, choose **Gray**.

Selection 1

- 1 Right-click **Surface 1** and choose **Selection**.
- 2 In the **Settings** window for **Selection**, locate the **Selection** section.
- 3 From the **Selection** list, choose **Source**.

Stress (solid)

Create a new view to plot the stress in the XY -plane.

- 1 In the **Model Builder** window, under **Results** click **Stress (solid)**.
- 2 In the **Settings** window for **3D Plot Group**, locate the **Plot Settings** section.
- 3 From the **View** list, choose **New view**.
- 4 In the **Stress (solid)** toolbar, click  **Plot**.
- 5 Click  **Go to Source**.

View 3D 2

- 1 Click the  **Go to XY View** button in the **Graphics** toolbar.
- 2 In the **Model Builder** window, under **Results** > **Views** click **View 3D 2**.
- 3 In the **Settings** window for **View 3D**, locate the **View** section.
- 4 Clear the **Show grid** checkbox.
- 5 Select the **Lock camera** checkbox.



This helps to ensure that the view is not accidentally changed.

Camera

- 1 In the **Model Builder** window, expand the **View 3D 2** node, then click **Camera**.
- 2 In the **Settings** window for **Camera**, locate the **Camera** section.
- 3 From the **Projection** list, choose **Orthographic**.

Add a plot showing the equivalent plastic strain from **Result Templates**.

RESULT TEMPLATES

- 1 In the **Results** toolbar, click  **Result Templates** to open the **Result Templates** window.
- 2 Go to the **Result Templates** window.
- 3 In the tree, select **Study 1/Solution 1 (sol1)** > **Solid Mechanics** > **Equivalent Plastic Strain (solid)**.
- 4 Click the **Add Result Template** button in the window toolbar.
- 5 In the **Results** toolbar, click  **Result Templates** to close the **Result Templates** window.

RESULTS

Deformation 1

- 1 In the **Model Builder** window, expand the **Results** > **Equivalent Plastic Strain (solid)** node.
- 2 Right-click **Surface 1** and choose **Deformation**.
- 3 In the **Settings** window for **Deformation**, locate the **Scale** section.
- 4 Select the **Scale factor** checkbox. In the associated text field, type 1.

Equivalent Plastic Strain (solid)



Add surface plot of the lock. You can write an arbitrary value in the expression field since a uniform color is used.

Surface 2

- 1 In the **Model Builder** window, right-click **Equivalent Plastic Strain (solid)** and choose **Surface**.

- 2 In the **Settings** window for **Surface**, locate the **Expression** section.
- 3 In the **Expression** text field, type 1.
- 4 Click to expand the **Title** section. From the **Title type** list, choose **None**.
- 5 Click to collapse the **Title** section. Locate the **Coloring and Style** section. From the **Coloring** list, choose **Uniform**.
- 6 From the **Color** list, choose **Gray**.

Selection 1

- 1 Right-click **Surface 2** and choose **Selection**.
- 2 In the **Settings** window for **Selection**, locate the **Selection** section.
- 3 From the **Selection** list, choose **Source**.
- 4 In the **Equivalent Plastic Strain (solid)** toolbar, click  **Plot**.
- 5 Click the  **Go to Default View** button in the **Graphics** toolbar to return to the model's default view.

Plot the reaction force needed to position the hook as function of the displacement.

Reaction Force

- 1 In the **Results** toolbar, click  **ID Plot Group**.
- 2 In the **Settings** window for **ID Plot Group**, type Reaction Force in the **Label** text field.
- 3 Locate the **Legend** section. Clear the **Show legends** checkbox.

Global 1

- 1 Right-click **Reaction Force** and choose **Global**.
- 2 In the **Settings** window for **Global**, locate the **y-Axis Data** section.
- 3 In the table, enter the following settings:

Expression	Unit	Description
2*solid.RFtotalx	N	Reaction force

The factor of two is included to give the total force needed to position the hook. The computed reaction forces correspond to a half of the real structure, since you make use of the symmetry.

- 4 Locate the **x-Axis Data** section. From the **Parameter** list, choose **Expression**.
- 5 In the **Expression** text field, type `disp(para)`.
- 6 From the **Unit** list, choose **mm**.
- 7 Click to expand the **Coloring and Style** section. From the **Width** list, choose **2**.

8 Find the **Line markers** subsection. From the **Marker** list, choose **Point**.

Add a color expression to distinguish the insertion and removal paths.

Color Expression 1

1 Right-click **Global 1** and choose **Color Expression**.

2 In the **Settings** window for **Color Expression**, locate the **Expression** section.

3 In the **Expression** text field, type para>1.

4 Click to expand the **Title** section. From the **Title type** list, choose **Manual**.

5 In the **Title** text area, type Insertion (green) and removal (red).

6 Locate the **Coloring and Style** section. From the **Color table** list, choose **TrafficLight**.

7 In the **Reaction Force** toolbar, click  **Plot**.