



Model created in COMSOL Multiphysics 6.4

# Small Punch Test for Ultrahigh Molecular Weight Polyethylene

## Introduction

---

Ultrahigh Molecular Weight (UHMW) Polyethylene is a material commonly employed in knee and hip joint replacements. The “small punch test” is designed to assess mechanical properties using very small samples, which because of their reduced size can be directly explanted. This example demonstrates the use of the Bergstrom–Bischoff material model in the **Polymer Viscoplasticity** feature available in the Nonlinear Structural Materials Module.

## Model Definition

---

In this model, a cylindrical test sample with a height,  $H$ , of 0.5 mm and a diameter,  $D$ , of 6.4 mm, is subjected to a biaxial state of tension by a hemispherical punch moving at a constant speed of 0.5 mm/min. Both the loading and unloading phases are modeled in the numerical simulation.

The geometry exhibits 2D axial symmetry. It is therefore possible to reduce the model geometry of the specimen to a rectangle with a width equal to its radius.

### MATERIAL MODEL

The rheology of the Bergstrom–Bischoff material model is shown in [Figure 1](#). It features a so-called equilibrium network that can be schematized as a hyperelastic spring characterized by an Arruda–Boyce strain energy, augmented with a first order dependence on the second invariant of the isochoric elastic Cauchy–Green deformation tensor as in [Ref. 1](#). The Cauchy stress is thus computed as

$$\sigma = \frac{1}{1+q} \left( \sigma_{AB} + q \frac{\mu_i}{J} \left( \bar{I}_1 \bar{b} - \frac{2}{3} \bar{I}_2 I - \bar{b}^2 \right) \right) \quad (1)$$

where  $\sigma_{AB}$  is the stress computed from a standard Arruda–Boyce hyperelastic material with quadratic, uncoupled volumetric strain energy,  $q$  is a weight on the relative contribution of the second isochoric invariant,  $J$  is the determinant of the deformation gradient,  $b$  is the isochoric left Cauchy–Green tensor, and  $I$  the second-order identity tensor. The material property  $\mu_i$  is the initial shear modulus, which is related to the macroscopic shear modulus  $\mu$  appearing in the five-terms Arruda–Boyce hyperelastic strain energy as ([Ref. 2](#))

$$\mu_i = \frac{\mu}{3} \sqrt{N} L^{-1} \left( \frac{1}{\sqrt{N}} \right)$$

where  $N$  is the number of segments and  $L^{-1}$  is the inverse Langevin function. Two more networks in parallel with the equilibrium network model the nonequilibrium behavior.

Each of the latter networks comprises an isochoric standard Arruda–Boyce spring in series with a viscoplastic element whose rate multiplier is given by

$$\lambda_i = A \left( \frac{\sigma_{vm}}{\sigma_{res,i} + a_i \max(p, 0)} \right)^{n_i} \quad (2)$$

where  $\sigma_{vm}$  is the von Mises stress of the nonequilibrium network and  $A$ ,  $a_i$ ,  $n_i$ , and  $\sigma_{res,i}$  identify material properties. The shear modulus of the nonequilibrium networks is set by an energy factor  $\beta_{vi}$  that represents the relative stiffness of the each nonequilibrium network with respect to the equilibrium one. The energy factor of the second nonequilibrium network is made dependent on the viscoplastic strain of the first one by the differential equation

$$\dot{\beta}_{v2} = (-\alpha)(\beta_{v2} - \beta_{v,f})\lambda_1$$

where  $\alpha$  and  $\beta_{v,f}$  are material properties.

The numerical values of the material properties used in the model are adapted from those used in Ref. 1 for the COMSOL Multiphysics implementation of the Bergstrom–Bischoff model.

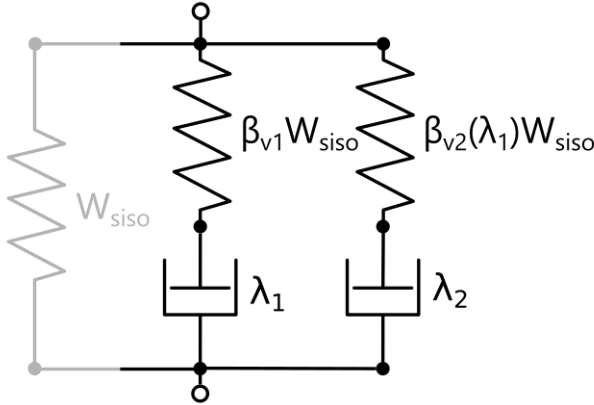

Figure 1: Rheology of the Bergstrom–Bischoff material model.

## Results and Discussion

Figure 2 shows the force versus punch displacement curve. The model is able to reproduce the failure of the specimen that occurs at a punch displacement of approximately 2.4 mm.

The punch force drops to zero during the unloading phase when it detaches from the specimen as a consequence of the viscoplastic deformation accumulated during the test.

Figure 3 shows the deformed shape of the specimen at the end of the simulation. The color highlights the first principal strain, where a circular region characterized by biaxial necking can be observed.

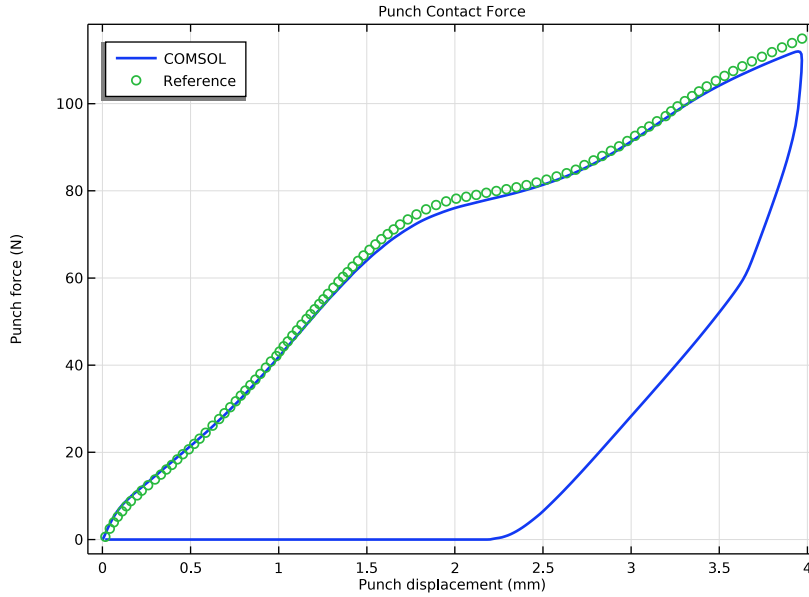
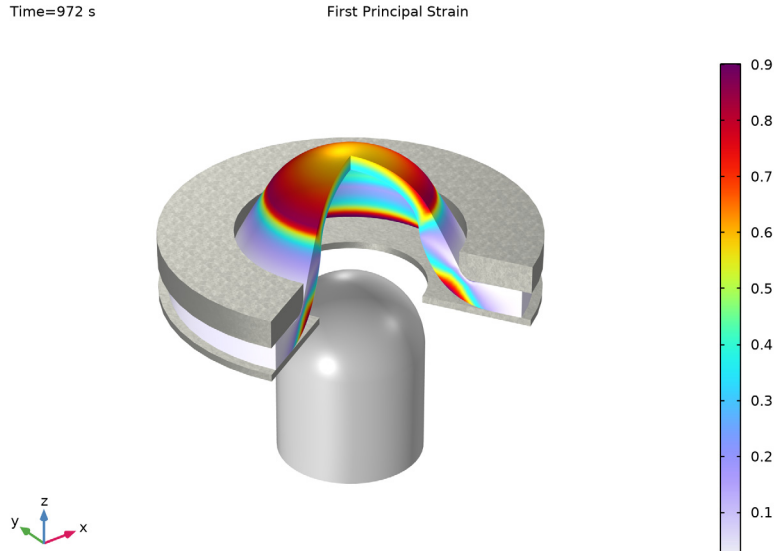

Figure 2: Force versus punch displacement curve.



*Figure 3: First principal strain in the specimen after the unloading phase.*

### *Notes About the COMSOL Implementation*

---

- The punch and the clamp are modeled as rigid bodies. The punch goes forward and backward at constant speed. The corresponding displacement can be imposed by defining a **Triangle** function found under **Definitions**. To facilitate convergence of the nonlinear solver, the **Smoothing** option is used, such that the resulting time history has at least two continuous derivatives. This is important not only at the time instant when the speed changes sign, but also at the initial time, in order to gradually start from zero speed. This allows to impose a motion that is consistent with the initial condition prescribing zero velocity.
- The **External stress** feature under **Hyperelastic Material** allows you to include the extra terms in the stress definition of the equilibrium network:

$$\frac{q}{1+q} \frac{\mu_i}{J} \left( \bar{I}_1 \bar{b} - \frac{2}{3} \bar{I}_2 I - \bar{b}^2 \right)$$

Note that while the second term can be easily added as an isotropic Cauchy stress, the first and the third terms are most easily added by computing the corresponding Second Piola–Kirchhoff stress tensor. Indeed, the first term becomes isotropic

$$\frac{q}{1+q} \mu_i J^{\frac{-2}{3}} \bar{I}_1 I \quad (3)$$

and the third can be expressed using the right Cauchy–Green deformation tensor  $C$

$$\frac{q}{1+q} \mu_i J^{\frac{-4}{3}} \bar{I}_1 C$$

- You can use the Bergstrom–Bischoff material model by adding a **Polymer Viscoplasticity** node under **Hyperelastic Material**.
- You find the **Domain ODEs** option in the **Time stepping** section of the **Polymer Viscoplasticity** node. This option can be faster than **Backward Euler** when the size of the problem is small.

## References

---

1. J.S. Bergström and J.E. Bischoff, “An Advanced Thermomechanical Constitutive Model for UHMWPE,” *International Journal of Structural Changes in Solids*, vol. 2, no. 1, pp. 31–39, 2010.
2. J.S. Bergström, *Mechanics of Solid polymers: Theory and Computational Modeling*, William Andrew, 2015.
3. J.S. Bergström and N. Elabbasi, “Nonlinear Mechanical Modeling of Thermoplastics,” *COMSOL Conference*, 2016.

---

**Application Library path:** Nonlinear\_Structural\_Materials\_Module/  
Viscoplasticity/small\_punch\_test

---

## Modeling Instructions



---

From the **File** menu, choose **New**.

## NEW

In the **New** window, click  **Model Wizard**.

## MODEL WIZARD

- 1 In the **Model Wizard** window, click  **2D Axisymmetric**.
- 2 In the **Select Physics** tree, select **Structural Mechanics > Solid Mechanics (solid)**.
- 3 Click **Add**.
- 4 Click  **Study**.
- 5 In the **Select Study** tree, select **General Studies > Time Dependent**.
- 6 Click  **Done**.

## GLOBAL DEFINITIONS

### *Geometrical Parameters*

- 1 In the **Model Builder** window, under **Global Definitions** click **Parameters I**.
- 2 In the **Settings** window for **Parameters**, locate the **Parameters** section.
- 3 Click  **Load from File**.
- 4 Browse to the model's Application Libraries folder and double-click the file `small_punch_test_geom_sequence_parameters.txt`.
- 5 In the **Label** text field, type `Geometrical Parameters`.

## GEOMETRY I

The geometry sequence for the model is available in a file. If you want to create it from scratch yourself, you can follow the instructions in the [Appendix — Geometry Modeling Instructions](#) section. Otherwise, insert the geometry sequence as follows:

- 1 In the **Geometry** toolbar, click **Insert Sequence** and choose **Insert Sequence**.
- 2 Browse to the model's Application Libraries folder and double-click the file `small_punch_test_geom_sequence.mph`.
- 3 In the **Geometry** toolbar, click  **Build All**.



Now set up the contact pairs. Choose as source of the pair the boundaries on the domains that will be modeled as rigid.

## DEFINITIONS

### Contact Pair 1 (ap1)

- 1 In the **Model Builder** window, expand the **Definitions** node, then click **Contact Pair 1 (ap1)**.
- 2 In the **Settings** window for **Pair**, click the  **Swap Source and Destination** button.

### Contact Pair 2 (ap2)

- 1 In the **Model Builder** window, click **Contact Pair 2 (ap2)**.
- 2 In the **Settings** window for **Pair**, click the  **Swap Source and Destination** button.
- 3 Locate the **Source Boundaries** section. Click to select the  **Activate Selection** toggle button.
- 4 Locate the **Pair Type** section. Select the **Manual control of selections and pair type** checkbox.
- 5 Select Boundaries 12, 14, and 16 only.
- 6 Click the  **Zoom Extents** button in the **Graphics** toolbar.



### Contact Pair 3 (p3)

- 1 In the **Definitions** toolbar, click  **Pairs** and choose **Contact Pair**.
- 2 Select Boundary 3 only.
- 3 In the **Settings** window for **Pair**, locate the **Destination Boundaries** section.
- 4 Click to select the  **Activate Selection** toggle button.
- 5 Select Boundary 5 only.

Set up the material models.



## GLOBAL DEFINITIONS

### Material Parameters

- 1 In the **Home** toolbar, click  **Parameters** and choose **Add > Parameters**.
- 2 In the **Settings** window for **Parameters**, locate the **Parameters** section.
- 3 Click  **Load from File**.
- 4 Browse to the model's Application Libraries folder and double-click the file `small_punch_test_material_parameters.txt`.
- 5 In the **Label** text field, type `Material Parameters`.

## SOLID MECHANICS (SOLID)

### *Hyperelastic Material 1*

- 1 In the **Physics** toolbar, click  **Domains** and choose **Hyperelastic Material**.
- 2 Select Domain 2 only.
- 3 In the **Settings** window for **Hyperelastic Material**, locate the **Hyperelastic Material** section.
- 4 From the **Material model** list, choose **Arruda–Boyce**.
- 5 From the **Compressibility** list, choose **Compressible, uncoupled**.
- 6 Locate the **Quadrature Settings** section. Select the **Reduced integration** checkbox.
- 7 Click the  **Show More Options** button in the **Model Builder** toolbar.
- 8 In the **Show More Options** dialog, in the tree, select the checkbox for the node **Physics > Advanced Physics Options**.
- 9 Click **OK**.
- 10 In the **Settings** window for **Hyperelastic Material**, click to expand the **Energy Dissipation** section.
- 11 From the **Store dissipation** list, choose **Domain ODEs (legacy)**.

### *Polymer Viscoplasticity 1*

- 1 In the **Physics** toolbar, click  **Attributes** and choose **Polymer Viscoplasticity**.
- 2 In the **Settings** window for **Polymer Viscoplasticity**, locate the **Viscoplasticity Model** section.
- 3 From the **Material model** list, choose **Bergstrom–Bischoff**.
- 4 Find the **Network 1** subsection. In the  $\beta_{v1}$  text field, type  $\text{betav1}/(1/(1+q))$ .
- 5 Find the **Network 2** subsection. In the  $\beta_{v,i}$  text field, type  $\text{betav2}_i/(1/(1+q))$ .
- 6 In the  $\beta_{v,f}$  text field, type  $\text{betav2}_f/(1/(1+q))$ .
- 7 In the  $\alpha$  text field, type  $\text{alfa\_rate}$ .
- 8 Locate the **Time Stepping** section. From the **Method** list, choose **Domain ODEs**.

## MATERIALS

### *UHMWPE*

- 1 In the **Model Builder** window, under **Component 1 (comp1)** right-click **Materials** and choose **Blank Material**.
- 2 Select Domain 2 only.
- 3 In the **Settings** window for **Material**, type UHMWPE in the **Label** text field.

4 Locate the **Material Contents** section. In the table, enter the following settings:

Property	Variable	Value	Unit	Property group
Bulk modulus	K	$\text{Kappa} * (1 / (1+q)) + 2 * \text{Kappa}$	N/m <sup>2</sup>	Bulk modulus and shear modulus
Number of segments	Nseg	N	l	Arruda-Boyce
Macroscopic shear modulus	mu0	$\text{mu} * (1 / (1+q))$	N/m <sup>2</sup>	Arruda-Boyce
Density	rho	0	kg/m <sup>3</sup>	Basic
Viscoplastic rate coefficient	A_BeBi	$1 [1/s] * \text{sqrt}(2/3)$	l/s	Bergstrom-Bischoff viscoplasticity
Flow resistance	sigRes1_BeBi	sig1res	N/m <sup>2</sup>	Bergstrom-Bischoff viscoplasticity
Stress exponent	n1_BeBi	if (t<1[s], 1, n)	l	Bergstrom-Bischoff viscoplasticity
Pressure hardening coefficient	a1_BeBi	$a / ((1 / (1+q)) + 2)$	l	Bergstrom-Bischoff viscoplasticity
Flow resistance	sigRes2_BeBi	sig2res	N/m <sup>2</sup>	Bergstrom-Bischoff viscoplasticity
Stress exponent	n2_BeBi	if (t<1[s], 1, n)	l	Bergstrom-Bischoff viscoplasticity
Pressure hardening coefficient	a2_BeBi	$1 / ((1 / (1+q)) + 2)$	l	Bergstrom-Bischoff viscoplasticity

The stress exponents of the Bergstrom–Bischoff model is reduced for small times to help initialize the solution.

## SOLID MECHANICS (SOLID)

### Hyperelastic Material 1

In the **Model Builder** window, under **Component 1 (comp1) > Solid Mechanics (solid)** click **Hyperelastic Material 1**.

### External Stress 1

- 1 In the **Physics** toolbar, click  **Attributes** and choose **External Stress**.
- 2 In the **Settings** window for **External Stress**, locate the **External Stress** section.
- 3 In the  $S_{\text{ext}}$  text field, type  $q / (1+q) * \text{mu\_initial} * \text{solid.J}^{(-2/3)} * \text{solid.I1C1e1}$ .

### Hyperelastic Material 1

In the **Model Builder** window, click **Hyperelastic Material 1**.

### External Stress 2

- 1 In the **Physics** toolbar, click  **Attributes** and choose **External Stress**.
- 2 In the **Settings** window for **External Stress**, locate the **External Stress** section.
- 3 From the **Stress input** list, choose **Stress tensor (Spatial)**.
- 4 In the  $\sigma_{\text{ext}}$  text field, type  $-(2/3)*q/(1+q)*\mu_{\text{initial}}*\text{solid.I2CIel}/\text{solid.J}$ .

### Hyperelastic Material 1

In the **Model Builder** window, click **Hyperelastic Material 1**.

### External Stress 3

- 1 In the **Physics** toolbar, click  **Attributes** and choose **External Stress**.
- 2 In the **Settings** window for **External Stress**, locate the **External Stress** section.
- 3 From the list, choose **Symmetric**.
- 4 Specify the  $S_{\text{ext}}$  matrix as

$-(q/(1+q))*\mu_{\text{initial}}*\text{solid.J}^{(-4/3)}*\text{solid.Cel11}$	$-(q/(1+q))*\mu_{\text{initial}}*\text{solid.J}^{(-4/3)}*\text{solid.Cel12}$	$-(q/(1+q))*\mu_{\text{initial}}*\text{solid.J}^{(-4/3)}*\text{solid.Cel13}$
$-(q/(1+q))*\mu_{\text{initial}}*\text{solid.J}^{(-4/3)}*\text{solid.Cel12}$	$-(q/(1+q))*\mu_{\text{initial}}*\text{solid.J}^{(-4/3)}*\text{solid.Cel22}$	$-(q/(1+q))*\mu_{\text{initial}}*\text{solid.J}^{(-4/3)}*\text{solid.Cel23}$
$-(q/(1+q))*\mu_{\text{initial}}*\text{solid.J}^{(-4/3)}*\text{solid.Cel13}$	$-(q/(1+q))*\mu_{\text{initial}}*\text{solid.J}^{(-4/3)}*\text{solid.Cel23}$	$-(q/(1+q))*\mu_{\text{initial}}*\text{solid.J}^{(-4/3)}*\text{solid.Cel33}$

## MATERIALS

### Steel

- 1 In the **Model Builder** window, under **Component 1 (comp1)** right-click **Materials** and choose **Blank Material**.
- 2 Select Domains 1, 3, and 4 only.
- 3 In the **Settings** window for **Material**, type **Steel** in the **Label** text field.

4 Locate the **Material Contents** section. In the table, enter the following settings:

Property	Variable	Value	Unit	Property group
Young's modulus	E	210 [GPa]	Pa	Young's modulus and Poisson's ratio
Poisson's ratio	nu	0.3	l	Young's modulus and Poisson's ratio
Density	rho	7800 [kg/m <sup>3</sup> ]	kg/m <sup>3</sup>	Basic

## SOLID MECHANICS (SOLID)

*Rigid Material: Clamp*

- 1 In the **Physics** toolbar, click  **Domains** and choose **Rigid Material**.
- 2 In the **Settings** window for **Rigid Material**, type Rigid Material: Clamp in the **Label** text field.
- 3 Select Domains 3 and 4 only.

*Fixed Constraint 1*

In the **Physics** toolbar, click  **Attributes** and choose **Fixed Constraint**.

*Rigid Material: Punch*

- 1 In the **Physics** toolbar, click  **Domains** and choose **Rigid Material**.
- 2 Select Domain 1 only.
- 3 In the **Settings** window for **Rigid Material**, type Rigid Material: Punch in the **Label** text field.

Define the imposed displacement for the punch.

## GLOBAL DEFINITIONS

*Test Parameters*



- 1 In the **Home** toolbar, click  **Parameters** and choose **Add > Parameters**.
- 2 In the **Settings** window for **Parameters**, type Test Parameters in the **Label** text field.
- 3 Locate the **Parameters** section. In the table, enter the following settings:

Name	Expression	Value	Description
wdot	0.5 [mm/min]	8.3333E-6 m/s	Speed of punch
wmax	4 [mm]	0.004 m	Maximum displacement
Dt	wmax/wdot	480 s	Time of movement

Name	Expression	Value	Description
Dt_transient	12[s]	12 s	Time of transient
Dt_tot	2*Dt+Dt_transient	972 s	Total time of simulation

## DEFINITIONS

### *Punch Displacement*

- 1 In the **Definitions** toolbar, click  **More Functions** and choose **Triangle**.
- 2 In the **Settings** window for **Triangle**, type Punch Displacement in the **Label** text field.
- 3 Locate the **Parameters** section. In the **Lower limit** text field, type Dt\_transient.
- 4 In the **Upper limit** text field, type Dt\_tot.
- 5 In the **Amplitude** text field, type wmax.
- 6 Click to expand the **Smoothing** section. In the **Size of transition zone** text field, type 20[s].
- 7 Click  **Plot**.

## SOLID MECHANICS (SOLID)

### *Rigid Material: Punch*

In the **Model Builder** window, under **Component 1 (comp1) > Solid Mechanics (solid)** click **Rigid Material: Punch**.

### *Prescribed Displacement/Rotation 1*

- 1 In the **Physics** toolbar, click  **Attributes** and choose **Prescribed Displacement/Rotation**.
- 2 In the **Settings** window for **Prescribed Displacement/Rotation**, locate the **Prescribed Displacement** section.
- 3 In the  $w_0$  text field, type tri1(t).  
Enable **Evaluate of reaction forces** to compute the punch reaction force.
- 4 Click to expand the **Reaction Force Settings** section. Select the **Evaluate reaction forces using weak constraints** checkbox.  
Inertia forces are negligible.
- 5 In the **Model Builder** window, click **Solid Mechanics (solid)**.
- 6 In the **Settings** window for **Solid Mechanics**, locate the **Structural Transient Behavior** section.
- 7 From the list, choose **Quasistatic**.

Adjust the contact settings.

#### Contact 1

- 1 In the **Model Builder** window, under **Component 1 (comp1) > Solid Mechanics (solid)** click **Contact 1**.
- 2 In the **Settings** window for **Contact**, click to expand the **Advanced** section.
- 3 In the  $E_{\text{char}}$  text field, type  $\text{solid.E} \cdot (1 + \beta_{\text{av1}} + \beta_{\text{av2\_i}})$ .

#### Friction 1

- 1 In the **Physics** toolbar, click  **Attributes** and choose **Friction**.
- 2 In the **Settings** window for **Friction**, locate the **Friction Parameters** section.
- 3 In the  $\mu$  text field, type 0.05.
- 4 Locate the **Friction Force Penalty Factor** section. From the **Penalty factor control** list, choose **Manual tuning**.
- 5 In the  $f_t$  text field, type 0.1.

Set up the mesh.

## GLOBAL DEFINITIONS

#### Mesh Parameters

- 1 In the **Home** toolbar, click  **Parameters** and choose **Add > Parameters**.
- 2 In the **Settings** window for **Parameters**, type Mesh Parameters in the **Label** text field.
- 3 Locate the **Parameters** section. In the table, enter the following settings:

Name	Expression	Value	Description
w_mesh	D/2/50	6.4E-5 m	Mesh element width
th_mesh	th/8	6.25E-5 m	Mesh element height

Draw partitions in order to improve the mesh.

## GEOMETRY 1

#### Rectangle 5 (r5)

- 1 In the **Geometry** toolbar, click  **Rectangle**.
- 2 In the **Settings** window for **Rectangle**, locate the **Size and Shape** section.
- 3 In the **Width** text field, type  $w_{\text{mesh}} \cdot 8$ .
- 4 In the **Height** text field, type  $th_{\text{mesh}} \cdot 2$ .
- 5 Locate the **Position** section. In the **r** text field, type  $w_{\text{mesh}} \cdot 28$ .

6 In the **z** text field, type `th-th_mesh*2`.

7 Click  **Build Selected**.

#### *Partition Domains 1 (pard1)*

1 In the **Geometry** toolbar, click  **Booleans and Partitions** and choose **Partition Domains**.

2 On the object **r1**, select Domain 1 only.

3 In the **Settings** window for **Partition Domains**, locate the **Partition Domains** section.

4 From the **Partition with** list, choose **Objects**.

5 Select the object **r5** only.

6 Clear the **Keep objects** checkbox.

7 Click  **Build Selected**.

#### *Rectangle 6 (r6)*

1 In the **Geometry** toolbar, click  **Rectangle**.

2 In the **Settings** window for **Rectangle**, locate the **Size and Shape** section.

3 In the **Width** text field, type `D/2`.

4 In the **Height** text field, type `th_mesh*2`.

5 Locate the **Position** section. In the **z** text field, type `th-th_mesh*2`.

6 Click  **Build Selected**.

#### *Partition Domains 2 (pard2)*

1 In the **Model Builder** window, under **Component 1 (comp1) > Geometry 1** right-click **Partition Domains 1 (pard1)** and choose **Duplicate**.

2 In the **Settings** window for **Partition Domains**, locate the **Partition Domains** section.

3 Click to select the  **Activate Selection** toggle button for **Domains to partition**.

4 On the object **pard1**, select Domain 1 only.

5 Click to select the  **Activate Selection** toggle button for **Objects**.

6 Select the object **r6** only.

7 Click  **Build Selected**.

#### *Mesh Control Edges 1 (mce1)*

1 In the **Model Builder** window, click **Mesh Control Edges 1 (mce1)**.

2 In the **Settings** window for **Mesh Control Edges**, locate the **Input** section.

3 Click to select the  **Activate Selection** toggle button for **Edges to include**.

4 On the object **fin**, select Boundaries 4, 10, 12, 13, 15, and 16 only.

## MESH 1

### *Mapped 1*

- 1 In the **Mesh** toolbar, click  **Mapped**.
- 2 In the **Settings** window for **Mapped**, locate the **Domain Selection** section.
- 3 From the **Geometric entity level** list, choose **Domain**.
- 4 Select Domain 7 only.



### *Distribution 1*

- 1 Right-click **Mapped 1** and choose **Distribution**.
- 2 Select Boundary 26 only.
- 3 In the **Settings** window for **Distribution**, locate the **Distribution** section.
- 4 In the **Number of elements** text field, type 8.

### *Distribution 2*

- 1 In the **Model Builder** window, right-click **Mapped 1** and choose **Distribution**.
- 2 Select Boundary 25 only.
- 3 In the **Settings** window for **Distribution**, locate the **Distribution** section.
- 4 In the **Number of elements** text field, type 2.
- 5 Click  **Build Selected**.

### *Convert 1*

- 1 In the **Mesh** toolbar, click  **Modify** and choose **Convert**.
- 2 In the **Settings** window for **Convert**, locate the **Element Split Method** section.
- 3 From the **Element split method** list, choose **Insert centerpoints**.
- 4 Locate the **Domain Selection** section. From the **Geometric entity level** list, choose **Domain**.
- 5 Select Domain 7 only.
- 6 Click  **Build Selected**.

### *Mapped 2*

- 1 In the **Mesh** toolbar, click  **Mapped**.
- 2 In the **Settings** window for **Mapped**, locate the **Domain Selection** section.
- 3 From the **Geometric entity level** list, choose **Domain**.
- 4 Select Domains 2, 6, and 8 only.

- 5 Click to expand the **Control Entities** section. From the **Smooth across removed control entities** list, choose **Off**.

#### *Distribution 1*

- 1 Right-click **Mapped 2** and choose **Distribution**.
- 2 Select Boundary 5 only.
- 3 In the **Settings** window for **Distribution**, locate the **Distribution** section.
- 4 In the **Number of elements** text field, type 50.

#### *Distribution 2*

- 1 In the **Model Builder** window, right-click **Mapped 2** and choose **Distribution**.
- 2 Select Boundary 4 only.
- 3 In the **Settings** window for **Distribution**, locate the **Distribution** section.
- 4 In the **Number of elements** text field, type 6.

#### *Distribution 3*

- 1 Right-click **Mapped 2** and choose **Distribution**.
- 2 Select Boundary 19 only.
- 3 In the **Settings** window for **Distribution**, locate the **Distribution** section.
- 4 In the **Number of elements** text field, type 2.
- 5 Click  **Build Selected**.

#### *Mapped 3*

- 1 In the **Mesh** toolbar, click  **Mapped**.
- 2 In the **Settings** window for **Mapped**, locate the **Domain Selection** section.
- 3 From the **Geometric entity level** list, choose **Domain**.
- 4 Select Domains 1 and 3 only.

#### *Distribution 1*

- 1 Right-click **Mapped 3** and choose **Distribution**.
- 2 Select Boundaries 9 and 18 only.
- 3 In the **Settings** window for **Distribution**, locate the **Distribution** section.
- 4 In the **Number of elements** text field, type 1.
- 5 Click  **Build Selected**.

#### *Free Triangular 1*

- 1 In the **Mesh** toolbar, click  **Free Triangular**.

- 2 In the **Settings** window for **Free Triangular**, click to expand the **Control Entities** section.
- 3 From the **Smooth across removed control entities** list, choose **Off**.

#### *Size*

- 1 In the **Model Builder** window, click **Size**.
- 2 In the **Settings** window for **Size**, locate the **Element Size** section.
- 3 From the **Predefined** list, choose **Finer**.
- 4 Click  **Build All**.

#### **STUDY 1**

- 1 In the **Model Builder** window, click **Study 1**.
- 2 In the **Settings** window for **Study**, locate the **Study Settings** section.
- 3 Clear the **Generate default plots** checkbox.

#### *Step 1: Time Dependent*

- 1 In the **Model Builder** window, under **Study 1** click **Step 1: Time Dependent**.
- 2 In the **Settings** window for **Time Dependent**, locate the **Study Settings** section.
- 3 In the **Output times** text field, type range (0,2,Dt\_tot).

#### *Solution 1 (sol1)*

- 1 In the **Study** toolbar, click  **Show Default Solver**.
- 2 In the **Model Builder** window, expand the **Solution 1 (sol1)** node.
- 3 In the **Model Builder** window, expand the **Study 1 > Solver Configurations > Solution 1 (sol1) > Dependent Variables 1** node, then click **Viscoplastic Strain Tensor, Local Coordinate System (comp1.solid.hmml.pvp1.evp1)**.
- 4 In the **Settings** window for **Field**, locate the **Scaling** section.
- 5 From the **Method** list, choose **Manual**.
- 6 In the **Scale** text field, type 3.
- 7 In the **Model Builder** window, under **Study 1 > Solver Configurations > Solution 1 (sol1) > Dependent Variables 1** click **Viscoplastic Strain Tensor, Local Coordinate System (comp1.solid.hmml.pvp1.evp2)**.
- 8 In the **Settings** window for **Field**, locate the **Scaling** section.
- 9 From the **Method** list, choose **Manual**.
- 10 In the **Scale** text field, type 3.

- 11 In the **Model Builder** window, under **Study 1 > Solver Configurations > Solution 1 (sol1) > Dependent Variables 1** click **Equivalent Viscoplastic Strain, Network 1 (comp1.solid.hmml.pvp1.evpe1)**.
- 12 In the **Settings** window for **Field**, locate the **Scaling** section.
- 13 From the **Method** list, choose **Manual**.
- 14 In the **Scale** text field, type 3.
- 15 In the **Model Builder** window, under **Study 1 > Solver Configurations > Solution 1 (sol1) > Dependent Variables 1** click **Equivalent Viscoplastic Strain, Network 2 (comp1.solid.hmml.pvp1.evpe2)**.
- 16 In the **Settings** window for **Field**, locate the **Scaling** section.
- 17 From the **Method** list, choose **Manual**.
- 18 In the **Scale** text field, type 3.
- 19 In the **Model Builder** window, under **Study 1 > Solver Configurations > Solution 1 (sol1) > Dependent Variables 1** click **Displacement Field (comp1.u)**.
- 20 In the **Settings** window for **Field**, locate the **Scaling** section.
- 21 In the **Scale** text field, type 4 [mm].
- 22 In the **Model Builder** window, under **Study 1 > Solver Configurations > Solution 1 (sol1) > Dependent Variables 1** click **Rigid Material Displacements (comp1.solid\_rd\_disp)**.
- 23 In the **Settings** window for **State**, locate the **Scaling** section.
- 24 In the **Scale** text field, type 4 [mm].
- 25 In the **Model Builder** window, under **Study 1 > Solver Configurations > Solution 1 (sol1) > Dependent Variables 1** click **Reaction Force (comp1.solid.rd2.RFz)**.
- 26 In the **Settings** window for **State**, locate the **Scaling** section.
- 27 From the **Method** list, choose **Manual**.
- 28 In the **Scale** text field, type 100.
- 29 In the **Model Builder** window, under **Study 1 > Solver Configurations > Solution 1 (sol1) > Dependent Variables 1** click **Viscoplastic Dissipation Density (comp1.solid.Wvp)**.
- 30 In the **Settings** window for **Field**, locate the **Scaling** section.
- 31 From the **Method** list, choose **Manual**.
- 32 In the **Scale** text field, type 1.0E7.
- 33 In the **Model Builder** window, under **Study 1 > Solver Configurations > Solution 1 (sol1)** click **Time-Dependent Solver 1**.

- 34 In the **Settings** window for **Time-Dependent Solver**, click to expand the **Time Stepping** section.
- 35 From the **Steps taken by solver** list, choose **Strict**.
- 36 In the **Model Builder** window, expand the **Study 1 > Solver Configurations > Solution 1 (sol1) > Time-Dependent Solver 1** node, then click **Direct**.
- 37 In the **Settings** window for **Direct**, locate the **General** section.
- 38 From the **Solver** list, choose **PARDISO**.
- 39 In the **Model Builder** window, under **Study 1 > Solver Configurations > Solution 1 (sol1) > Time-Dependent Solver 1** click **Fully Coupled 1**.
- 40 In the **Settings** window for **Fully Coupled**, click to expand the **Method and Termination** section.
- 41 In the **Minimum damping factor** text field, type 0.3.
- 42 In the **Maximum number of iterations** text field, type 20.
- 43 In the **Study** toolbar, click  $t=0$  **Get Initial Value**.

## RESULTS

In the **Model Builder** window, expand the **Results** node.

### *Displacement Magnitude*

- 1 In the **Model Builder** window, expand the **Results > Datasets** node.
- 2 Right-click **Results** and choose **2D Plot Group**.
- 3 In the **Settings** window for **2D Plot Group**, type **Displacement Magnitude** in the **Label** text field.
- 4 Locate the **Plot Settings** section. From the **Frame** list, choose **Spatial (r, phi, z)**.

### *Polymer*

- 1 Right-click **Displacement Magnitude** and choose **Surface**.
- 2 In the **Settings** window for **Surface**, type **Polymer** in the **Label** text field.

### *Selection 1*

- 1 Right-click **Polymer** and choose **Selection**.
- 2 Select Domain 2 only.

### *Deformation 1*

- 1 In the **Model Builder** window, right-click **Polymer** and choose **Deformation**.
- 2 In the **Settings** window for **Deformation**, locate the **Scale** section.
- 3 Select the **Scale factor** checkbox. In the associated text field, type 1.

### *Punch and Clamp*

- 1 In the **Model Builder** window, right-click **Displacement Magnitude** and choose **Surface**.
- 2 In the **Settings** window for **Surface**, type **Punch and Clamp** in the **Label** text field.
- 3 Click to expand the **Title** section. From the **Title type** list, choose **None**.
- 4 Locate the **Expression** section. In the **Expression** text field, type 1.
- 5 Locate the **Coloring and Style** section. From the **Coloring** list, choose **Uniform**.
- 6 From the **Color** list, choose **Gray**.

### *Selection 1*



- 1 Right-click **Punch and Clamp** and choose **Selection**.
- 2 Select Domains 1, 3, and 4 only.

### *Deformation 1*

- 1 In the **Model Builder** window, right-click **Punch and Clamp** and choose **Deformation**.
- 2 In the **Settings** window for **Deformation**, locate the **Scale** section.
- 3 Select the **Scale factor** checkbox. In the associated text field, type 1.

## **STUDY 1**

### *Step 1: Time Dependent*

- 1 In the **Model Builder** window, under **Study 1** click **Step 1: Time Dependent**.
- 2 In the **Settings** window for **Time Dependent**, click to expand the **Results While Solving** section.
- 3 Select the **Plot** checkbox.
- 4 In the **Study** toolbar, click  **Compute**.
- 5 Click the  **Zoom Extents** button in the **Graphics** toolbar.

## **RESULTS**

### *Punch Force*

- 1 In the **Results** toolbar, click  **ID Plot Group**.
- 2 In the **Settings** window for **ID Plot Group**, type **Punch Force** in the **Label** text field.
- 3 Click to expand the **Title** section. From the **Title type** list, choose **Manual**.
- 4 In the **Title** text area, type **Punch Contact Force**.
- 5 Locate the **Plot Settings** section.

- 6 Select the **x-axis label** checkbox. In the associated text field, type Punch displacement (mm).
- 7 Select the **y-axis label** checkbox. In the associated text field, type Punch force (N).
- 8 Locate the **Grid** section. Select the **Manual spacing** checkbox.
- 9 In the **x spacing** text field, type 0.5.
- 10 In the **y spacing** text field, type 20.
- 11 Locate the **Legend** section. From the **Position** list, choose **Upper left**.

#### Global 1

- 1 Right-click **Punch Force** and choose **Global**.
- 2 In the **Settings** window for **Global**, locate the **y-Axis Data** section.
- 3 In the table, enter the following settings:

Expression	Unit	Description
solid.rd2.RFz	N	Reaction force

- 4 Locate the **x-Axis Data** section. From the **Parameter** list, choose **Expression**.
- 5 In the **Expression** text field, type  $\text{tri1}(t)$ .
- 6 Click to expand the **Coloring and Style** section. From the **Width** list, choose **2**.

Import numerical data from [Ref. 1](#) for comparison.

#### Reference

- 1 In the **Results** toolbar, click  **Table**.
- 2 In the **Settings** window for **Table**, type Reference in the **Label** text field.
- 3 Locate the **Data** section. Click  **Import**.
- 4 Browse to the model's Application Libraries folder and double-click the file `small_punch_test_numerical.txt`.

#### Reference

- 1 In the **Model Builder** window, right-click **Punch Force** and choose **Table Graph**.
- 2 In the **Settings** window for **Table Graph**, type Reference in the **Label** text field.
- 3 Locate the **Coloring and Style** section. Find the **Line style** subsection. From the **Line** list, choose **None**.
- 4 Find the **Line markers** subsection. From the **Marker** list, choose **Circle**.
- 5 Click to expand the **Legends** section. Select the **Show legends** checkbox.
- 6 Find the **Include** subsection. Select the **Label** checkbox.

7 Clear the **Headers** checkbox.

#### COMSOL

- 1 In the **Model Builder** window, under **Results > Punch Force** click **Global 1**.
- 2 In the **Settings** window for **Global**, type COMSOL in the **Label** text field.
- 3 Click to expand the **Legends** section. Find the **Include** subsection. Select the **Label** checkbox.
- 4 Clear the **Solution** checkbox.
- 5 Clear the **Description** checkbox.
- 6 In the **Punch Force** toolbar, click  **Plot**.

#### Dissipated Energy

- 1 In the **Results** toolbar, click  **ID Plot Group**.
- 2 In the **Settings** window for **ID Plot Group**, type Dissipated Energy in the **Label** text field.
- 3 Locate the **Title** section. From the **Title type** list, choose **Manual**.
- 4 In the **Title** text area, type Dissipated Energy.

#### Global 1

- 1 Right-click **Dissipated Energy** and choose **Global**.
- 2 In the **Settings** window for **Global**, click **Replace Expression** in the upper-right corner of the **y-Axis Data** section. From the menu, choose **Component 1 (comp1) > Solid Mechanics > Global > solid.Wvp\_tot - Total viscoplastic dissipation - J**.
- 3 Locate the **x-Axis Data** section. From the **Parameter** list, choose **Expression**.
- 4 In the **Expression** text field, type  $\text{tri1}(t)$ .
- 5 Locate the **Coloring and Style** section. From the **Width** list, choose **2**.
- 6 Locate the **Legends** section. Clear the **Show legends** checkbox.
- 7 In the **Dissipated Energy** toolbar, click  **Plot**.

#### Revolution 2D: Polymer

- 1 In the **Results** toolbar, click  **More Datasets** and choose **Revolution 2D**.
- 2 In the **Settings** window for **Revolution 2D**, type Revolution 2D: Polymer in the **Label** text field.
- 3 Click to expand the **Revolution Layers** section. In the **Start angle** text field, type -60.
- 4 In the **Revolution angle** text field, type 270.

### *Selection*

- 1 In the **Results** toolbar, click  **Attributes** and choose **Selection**.
- 2 In the **Settings** window for **Selection**, locate the **Geometric Entity Selection** section.
- 3 From the **Geometric entity level** list, choose **Domain**.
- 4 Select Domain 2 only.

### *First Principal Strain*

- 1 In the **Results** toolbar, click  **3D Plot Group**.
- 2 In the **Settings** window for **3D Plot Group**, type First Principal Strain in the **Label** text field.
- 3 Locate the **Plot Settings** section. Clear the **Plot dataset edges** checkbox.
- 4 Click to expand the **Title** section. From the **Title type** list, choose **Label**.

### *Polymer*

- 1 Right-click **First Principal Strain** and choose **Volume**.
- 2 In the **Settings** window for **Volume**, locate the **Expression** section.
- 3 In the **Expression** text field, type solid.ep1.
- 4 Locate the **Coloring and Style** section. From the **Color table** list, choose **Prism**.
- 5 In the **Label** text field, type Polymer.

### *Deformation 1*

- 1 Right-click **Polymer** and choose **Deformation**.
- 2 In the **Settings** window for **Deformation**, locate the **Scale** section.
- 3 Select the **Scale factor** checkbox. In the associated text field, type 1.

### *Revolution 2D: Punch*

- 1 In the **Model Builder** window, right-click **Revolution 2D: Polymer** and choose **Duplicate**.
- 2 In the **Settings** window for **Revolution 2D**, type Revolution 2D: Punch in the **Label** text field.
- 3 Locate the **Revolution Layers** section. In the **Start angle** text field, type 0.
- 4 In the **Revolution angle** text field, type 360.

### *Selection*

- 1 In the **Model Builder** window, expand the **Revolution 2D: Punch** node, then click **Selection**.
- 2 Select Domain 1 only.

### *Punch*

- 1 In the **Model Builder** window, right-click **First Principal Strain** and choose **Surface**.
- 2 In the **Settings** window for **Surface**, type **Punch** in the **Label** text field.
- 3 Locate the **Data** section. From the **Dataset** list, choose **Revolution 2D: Punch**.
- 4 From the **Solution parameters** list, choose **From parent**.
- 5 Locate the **Expression** section. In the **Expression** text field, type 1.
- 6 Locate the **Coloring and Style** section. From the **Coloring** list, choose **Uniform**.
- 7 From the **Color** list, choose **Gray**.

### *Deformation 1*

- 1 Right-click **Punch** and choose **Deformation**.
- 2 In the **Settings** window for **Deformation**, locate the **Scale** section.
- 3 Select the **Scale factor** checkbox. In the associated text field, type 1.

### *Revolution 2D: Clamp*

- 1 In the **Model Builder** window, right-click **Revolution 2D: Punch** and choose **Duplicate**.
- 2 In the **Settings** window for **Revolution 2D**, type **Revolution 2D: Clamp** in the **Label** text field.
- 3 Locate the **Revolution Layers** section. In the **Start angle** text field, type -60.
- 4 In the **Revolution angle** text field, type 270.

### *Selection*

- 1 In the **Model Builder** window, expand the **Revolution 2D: Clamp** node, then click **Selection**.
- 2 Select Domains 3 and 4 only.

### *Clamp*

- 1 In the **Model Builder** window, right-click **First Principal Strain** and choose **Volume**.
- 2 In the **Settings** window for **Volume**, type **Clamp** in the **Label** text field.
- 3 Locate the **Data** section. From the **Dataset** list, choose **Revolution 2D: Clamp**.
- 4 From the **Solution parameters** list, choose **From parent**.
- 5 Locate the **Expression** section. In the **Expression** text field, type 1.
- 6 Locate the **Coloring and Style** section. From the **Coloring** list, choose **Uniform**.
- 7 From the **Color** list, choose **Gray**.

### *Material Appearance 1*

- 1 Right-click **Clamp** and choose **Material Appearance**.
- 2 In the **Settings** window for **Material Appearance**, locate the **Appearance** section.
- 3 From the **Appearance** list, choose **Custom**.
- 4 From the **Material type** list, choose **Steel (scratched)**.
- 5 In the **First Principal Strain** toolbar, click  **Plot**.

### *Appendix — Geometry Modeling Instructions*

---

From the **File** menu, choose **New**.

#### **NEW**

In the **New** window, click  **Model Wizard**.

#### **MODEL WIZARD**

- 1 In the **Model Wizard** window, click  **2D Axisymmetric**.
- 2 Click  **Done**.

#### **GLOBAL DEFINITIONS**

##### *Geometrical Parameters*

- 1 In the **Model Builder** window, under **Global Definitions** click **Parameters 1**.
- 2 In the **Settings** window for **Parameters**, locate the **Parameters** section.
- 3 Click  **Load from File**.
- 4 Browse to the model's Application Libraries folder and double-click the file `small_punch_test_geom_sequence_parameters.txt`.
- 5 In the **Label** text field, type `Geometrical Parameters`.

#### **GEOMETRY 1**

- 1 In the **Model Builder** window, under **Component 1 (comp1)** click **Geometry 1**.
- 2 In the **Settings** window for **Geometry**, locate the **Units** section.
- 3 From the **Length unit** list, choose **mm**.

##### *Rectangle 1 (r1)*

- 1 In the **Geometry** toolbar, click  **Rectangle**.
- 2 In the **Settings** window for **Rectangle**, locate the **Size and Shape** section.
- 3 In the **Width** text field, type `D/2`.

4 In the **Height** text field, type  $th$ .

#### *Rectangle 2 (r2)*

- 1 In the **Geometry** toolbar, click  **Rectangle**.
- 2 In the **Settings** window for **Rectangle**, locate the **Size and Shape** section.
- 3 In the **Width** text field, type  $r_{out\_clamp-r\_bottom}$ .
- 4 In the **Height** text field, type  $th/4$ .
- 5 Locate the **Position** section. In the **r** text field, type  $r\_bottom$ .
- 6 In the **z** text field, type  $-th/4$ .



#### *Rectangle 3 (r3)*

- 1 In the **Geometry** toolbar, click  **Rectangle**.
- 2 In the **Settings** window for **Rectangle**, locate the **Size and Shape** section.
- 3 In the **Width** text field, type  $r_{out\_clamp-r\_top}$ .
- 4 In the **Height** text field, type  $th$ .
- 5 Locate the **Position** section. In the **r** text field, type  $r\_top$ .
- 6 In the **z** text field, type  $th$ .

#### *Circle 1 (c1)*

- 1 In the **Geometry** toolbar, click  **Circle**.
- 2 In the **Settings** window for **Circle**, locate the **Size and Shape** section.
- 3 In the **Radius** text field, type  $r\_punch$ .
- 4 In the **Sector angle** text field, type  $90$ .
- 5 Locate the **Position** section. In the **z** text field, type  $-r\_punch$ .

#### *Rectangle 4 (r4)*



- 1 In the **Geometry** toolbar, click  **Rectangle**.
- 2 In the **Settings** window for **Rectangle**, locate the **Size and Shape** section.
- 3 In the **Width** text field, type  $r\_punch$ .
- 4 In the **Height** text field, type  $h\_punch-r\_punch$ .
- 5 Locate the **Position** section. In the **z** text field, type  $-h\_punch$ .
- 6 Click  **Build Selected**.
- 7 Click the  **Zoom Extents** button in the **Graphics** toolbar.

#### *Fillet 1 (fil1)*

- 1 In the **Geometry** toolbar, click  **Fillet**.

- 2 On the object **r3**, select Point 1 only.
- 3 In the **Settings** window for **Fillet**, locate the **Radius** section.
- 4 In the **Radius** text field, type `r_fillet`.



#### *Union 1 (un1)*

- 1 In the **Geometry** toolbar, click  **Booleans and Partitions** and choose **Union**.
- 2 Select the objects **c1** and **r4** only.
- 3 In the **Settings** window for **Union**, click  **Build Selected**.
- 4 Click  **Build Selected**.

#### *Form Union (fin)*

- 1 In the **Model Builder** window, under **Component 1 (comp1) > Geometry 1** click **Form Union (fin)**.
- 2 In the **Settings** window for **Form Union/Assembly**, locate the **Form Union/Assembly** section.
- 3 From the **Action** list, choose **Form an assembly**.
- 4 From the **Pair type** list, choose **Contact pair**.
- 5 In the **Geometry** toolbar, click  **Build All**.

#### *Mesh Control Edges 1 (mce1)*

- 1 In the **Geometry** toolbar, click  **Virtual Operations** and choose **Mesh Control Edges**.
- 2 On the object **fin**, select Boundary 4 only.
- 3 In the **Geometry** toolbar, click  **Build All**.