



Model created in COMSOL Multiphysics 6.4

# Contact Analysis of a Rubber Boot Seal

## *Introduction*

---

Rubber boot seals are used in several industrial applications to protect flexible joints from dirt, dust, humidity and other environmental agents, as well as to prevent leakage of lubricants. In, for example, the automotive industry they are used for joints on the drive shaft among other applications. Many of these joints can undergo large deformations, hence a rubber boot seal needs to be designed to accommodate severe deformation, including both rotation and elongation, without breaking. To accomplish this the seals are generally made from synthetic elastomers that can be exposed to significant stretching without rupturing.

In this example, the deformation of a so-called multiconvolution boot seal connected to a rigid pipe is studied. As the pipe rotates and the seal deforms, the flanges of the seal self-intersect and it also come into contact with the pipe. This causes significant deformation of the rubber.

## *Model Definition*

---

[Figure 1](#) shows the geometry of the boot seal and the connected pipe. The seal has five convolutions with decreasing radius to seal the pipe to its mating surface.

]

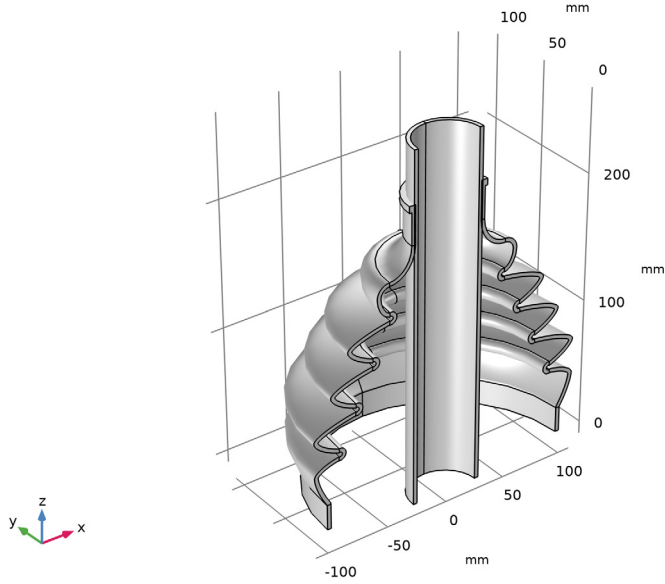

*Figure 1: Model geometry.*

The pipe is in the example assumed be rigid and a generic rubber material is used for the boot seal. The mechanical behavior of the rubber is described by a nearly incompressible Yeoh hyperelastic model which isochoric strain energy is given as

$$W_s = c_1(\bar{I}_1 - 3) + c_2(\bar{I}_1 - 3)^2 + c_3(\bar{I}_1 - 3)^3$$

where the material constants used are  $c_1 = 100$  kPa,  $c_2 = 6$  kPa, and  $c_3 = 0$  Pa.

The study is divided in two steps. In the first step the seal is mounted on the pipe which has a slightly larger diameter compared to the seal. This will create a shrink fit connection that ensures a tight seal. In the second step, a rotation of 40 degrees around the  $y$ -axis is incrementally applied to the bottom of the pipe. Given that the deformation is only applied around a single axis, one symmetry plane is utilized such that only half of the seal is modeled. The bottom of the seal is fixed in both study steps.

Since the pipe and seal are created as two disconnected parts in an assembly, a contact condition is set up between the exterior of the pipe and the interior of the seal. The contact condition also includes Coulomb friction with a friction coefficient equal to 0.7, which is representative for metal to rubber contact. Moreover, as the pipe is rotated the

deformation of the seal will be large enough to cause its flanges to self-intersect. To avoid any unphysical overlap of boundaries, self-contact conditions are also set up for both the interior and exterior boundaries. Friction is also considered for these interactions with a friction coefficient equal to 0.8, which is typical for rubber to rubber contact. The Nitsche method is used to implement all contact conditions in the model since it has better accuracy compared to, for example, the penalty method. This is especially important for problems where the contact surfaces undergo large deformations as the seal in this example.

### Results and Discussion

Figure 2 shows the deformed shape of the seal at the end of the second step at a 40-degree rotation of the pipe. It can clearly be seen how the flanges at the compressed side of the seal are folded and in contact with themselves. The highest stress in the seal is on the opposite side where it is stretched. Even though there are significant stress concentrations visible, the magnitude is still well below the typical tensile strength of rubber.

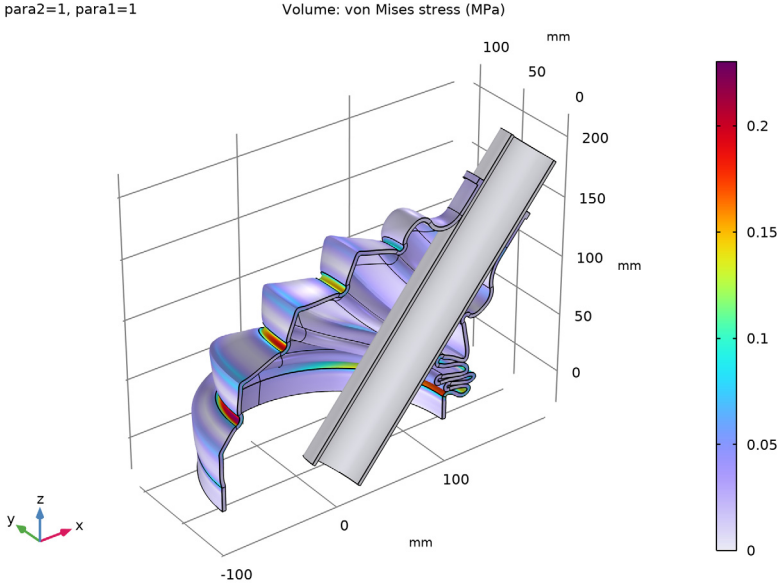
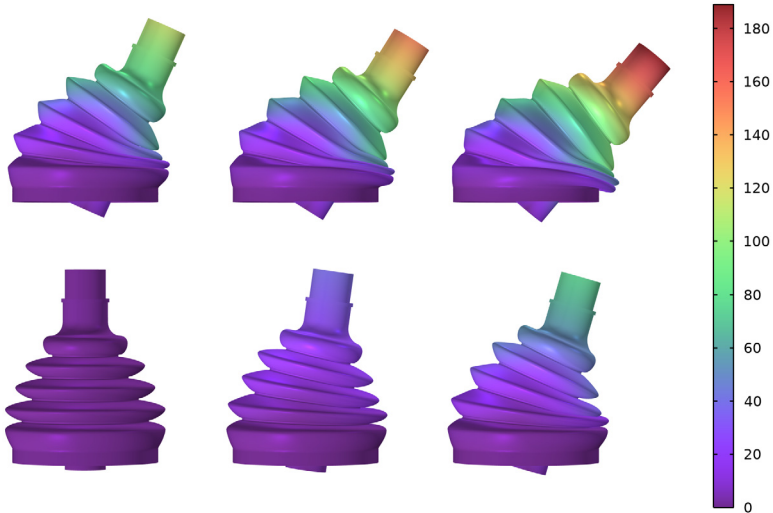
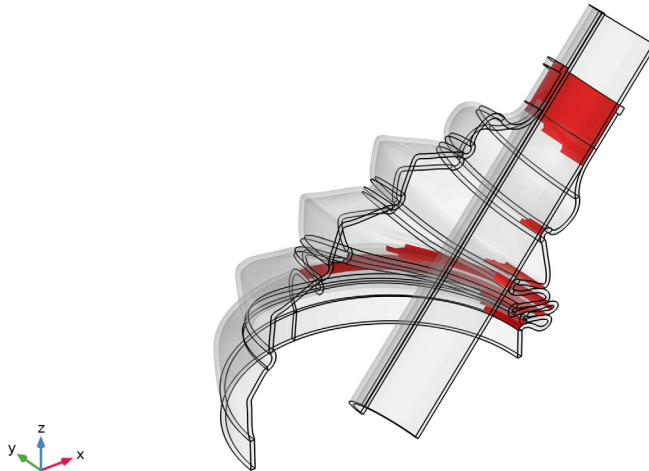

Figure 2: Deformed shape and stress distribution.

The deformation at different rotations of the pipe is shown in Figure 3 and the surfaces in contact at the final step are highlighted in Figure 4. In the latter figure one can clearly see that contact occurs between both interior and exterior surface of the seal, but also between the seal and the pipe at different locations.



*Figure 3: Deformed shape at increasing rotations of the pipe. Displacement are given in millimeters.*



*Figure 4: Parts of the surface of the seal in contact with another surface highlighted in red.*

### *Notes About the COMSOL Implementation*

---

Self-contact is in COMSOL Multiphysics modeled by selecting the same boundaries as source and destination in a **Contact Pair**. Here three contact pairs are used, one with an unsymmetric selection to set up contact between the pipe and the interior of the seal, and two with a symmetric selection to define self-contact between the interior and exterior surfaces of the seal.

When modeling self-contact of convoluted surfaces it is recommended to manually control the search distance of the **Contact Pair**. The automatic search distance is based on the size of the geometry and can lead to false detection of contact points on, for example, the backside of the surface at which considered the contact point is located. Here a much smaller search distance is used for the two contact pairs used for the self-contact. Apart from making the contact search more robust, using a smaller search distance will also improve the performance of the search algorithm.

---

**Application Library path:** Nonlinear\_Structural\_Materials\_Module/  
Hyperelasticity/rubber\_boot\_seal

---

### *Modeling Instructions*



---

From the **File** menu, choose **New**.

#### **NEW**

In the **New** window, click  **Model Wizard**.

#### **MODEL WIZARD**

- 1 In the **Model Wizard** window, click  **3D**.
- 2 In the **Select Physics** tree, select **Structural Mechanics > Solid Mechanics (solid)**.
- 3 Click **Add**.
- 4 Click  **Study**.
- 5 In the **Select Study** tree, select **General Studies > Stationary**.
- 6 Click  **Done**.

#### **GLOBAL DEFINITIONS**

##### *Parameters 1*

- 1 In the **Model Builder** window, under **Global Definitions** click **Parameters 1**.
- 2 In the **Settings** window for **Parameters**, locate the **Parameters** section.
- 3 In the table, enter the following settings:

<b>Name</b>	<b>Expression</b>	<b>Value</b>	<b>Description</b>
overlap	1[mm]	0.001 m	Shrink fit overlap
para1	0	0	Continuation parameter, step 1
para2	0	0	Continuation parameter, step 2

#### **GEOMETRY 1**

The geometry sequence for the model is available in a file. If you want to create it from scratch yourself, you can follow the instructions in the [Appendix — Geometry Modeling Instructions](#) section. Otherwise, insert the geometry sequence as follows:

- 1 In the **Geometry** toolbar, click **Insert Sequence** and choose **Insert Sequence**.
- 2 Browse to the model's Application Libraries folder and double-click the file `rubber_boot_seal_geom_sequence.mph`.

#### *Cylinder 1 (cyl1)*

The outer radius of the cylinder is larger than the inner radius in order to create a shrink fit.

- 1 In the **Model Builder** window, under **Component 1 (comp1) > Geometry 1** click **Cylinder 1 (cyl1)**.
- 2 In the **Settings** window for **Cylinder**, locate the **Size and Shape** section.
- 3 In the **Radius** text field, type  $(60) / 2 - 3 + \text{overlap}$ .
- 4 In the **Geometry** toolbar, click  **Build All**.

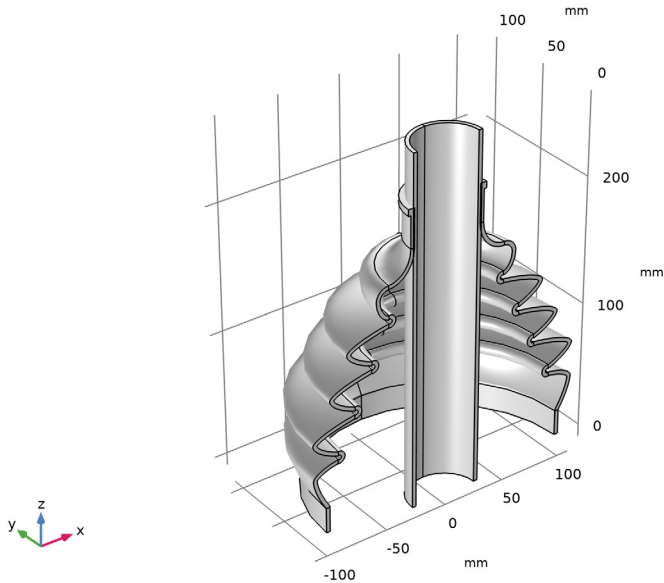

## DEFINITIONS

### *Contact Surface, Outside*



- 1 In the **Definitions** toolbar, click  **Explicit**.
- 2 In the **Settings** window for **Explicit**, type **Contact Surface, Outside** in the **Label** text field.
- 3 Locate the **Input Entities** section. From the **Geometric entity level** list, choose **Boundary**.

- 4 Select Boundaries 63, 66, 69, 75, 79, 83, 87, 91, and 95 only.

#### *Contact Surface, Inside*

- 1 In the **Definitions** toolbar, click  **Explicit**.
- 2 In the **Settings** window for **Explicit**, type Contact Surface, Inside in the **Label** text field.
- 3 Locate the **Input Entities** section. From the **Geometric entity level** list, choose **Boundary**.
- 4 Select Boundaries 70, 71, 73, 80, 81, 88, 89, 96, and 97 only.

#### *Contact Pair 1 (p1)*

- 1 In the **Definitions** toolbar, click  **Pairs** and choose **Contact Pair**.
- 2 Select Boundaries 116 and 124 only.
- 3 In the **Settings** window for **Pair**, locate the **Destination Boundaries** section.
- 4 Click to select the  **Activate Selection** toggle button.
- 5 Select Boundaries 41, 51, 53, 56, 70, 80, 88, and 96 only.

#### *Contact Pair 2 (p2)*

- 1 In the **Definitions** toolbar, click  **Pairs** and choose **Contact Pair**.  
To model self-contact, select the same boundaries as source and destination.
- 2 In the **Settings** window for **Pair**, locate the **Source Boundaries** section.
- 3 From the **Selection** list, choose **Contact Surface, Outside**.
- 4 Locate the **Destination Boundaries** section. From the **Selection** list, choose **Contact Surface, Outside**.
- 5 Locate the **Advanced** section. From the **Search distance** list, choose **Manual**.  
The automatic search distance is based on the size of the geometry. Use a smaller search distance to improve performance and also to avoid detecting false contact points due to the convoluted geometry of the seal.
- 6 In the **Distance** text field, type 1.

#### *Contact Pair 3 (p3)*

- 1 In the **Definitions** toolbar, click  **Pairs** and choose **Contact Pair**.
- 2 In the **Settings** window for **Pair**, locate the **Source Boundaries** section.
- 3 From the **Selection** list, choose **Contact Surface, Inside**.
- 4 Locate the **Destination Boundaries** section. From the **Selection** list, choose **Contact Surface, Inside**.
- 5 Locate the **Advanced** section. From the **Search distance** list, choose **Manual**.

6 In the **Distance** text field, type 1.

## **SOLID MECHANICS (SOLID)**

### *Hyperelastic Material 1*

- 1 In the **Physics** toolbar, click  **Domains** and choose **Hyperelastic Material**.
- 2 In the **Settings** window for **Hyperelastic Material**, locate the **Domain Selection** section.
- 3 From the **Selection** list, choose **All domains**.
- 4 Locate the **Hyperelastic Material** section. From the **Material model** list, choose **Yeoh**.
- 5 From the **Volumetric strain energy** list, choose **Hartmann–Neff**.

The pipe is assumed to be rigid.

### *Rigid Material 1*

- 1 In the **Physics** toolbar, click  **Domains** and choose **Rigid Material**.
- 2 Select Domains 25 and 26 only.

### *Prescribed Displacement/Rotation 1*

- 1 In the **Physics** toolbar, click  **Attributes** and choose **Prescribed Displacement/Rotation**.  
Apply a rotation around the  $y$ -axis at the bottom of the pipe in the second study step using para2.
- 2 In the **Settings** window for **Prescribed Displacement/Rotation**, locate the **Center of Rotation** section.
- 3 From the list, choose **Centroid of selected entities**.
- 4 Locate the **Prescribed Displacement at Center of Rotation** section. Select the **Prescribed in x direction** checkbox.
- 5 Select the **Prescribed in y direction** checkbox.
- 6 Select the **Prescribed in z direction** checkbox.
- 7 Locate the **Prescribed Rotation** section. From the **By** list, choose **Prescribed rotation**.
- 8 Specify the  $\Omega$  vector as

0	x
1	y
0	z

- 9 In the  $\phi_0$  text field, type  $40[\text{deg}] * \text{para2}$ .

### *Center of Rotation: Boundary 1*

- 1 In the **Model Builder** window, click **Center of Rotation: Boundary 1**.
- 2 Select Boundaries 117 and 122 only.

### *Contact (Pipe-Seal)*

The Nitsche contact method is better at resolving the contact condition for large deformation problems.

- 1 In the **Model Builder** window, under **Component 1 (comp1) > Solid Mechanics (solid)** click **Contact 1**.
- 2 In the **Settings** window for **Contact**, locate the **Contact Method** section.
- 3 From the list, choose **Nitsche**.  
Create the shrink fit at the top connection of the seal to the pipe by adding an offset to the destination surface that will be removed incrementally.
- 4 Click to expand the **Contact Surface Offset and Adjustment** section. In the  $d_{\text{offset},s}$  text field, type  $-\text{overlap} * (1 - \min(\text{para1}, 1))$ .
- 5 In the **Label** text field, type Contact (Pipe-Seal).

### *Friction 1*

- 1 In the **Physics** toolbar, click  **Attributes** and choose **Friction**.
- 2 In the **Settings** window for **Friction**, locate the **Friction Parameters** section.
- 3 In the  $\mu$  text field, type 0.7.

Add a second **Contact** node for the self-contact of the rubber seal.

### *Contact (Seal-Seal)*

- 1 In the **Physics** toolbar, click  **Pairs** and choose **Contact**.
- 2 In the **Settings** window for **Contact**, locate the **Pair Selection** section.
- 3 Click **+ Add**.
- 4 In the **Add** dialog, in the **Pairs** list, choose **Contact Pair 2 (p2)** and **Contact Pair 3 (p3)**.
- 5 Click **OK**.
- 6 In the **Settings** window for **Contact**, locate the **Contact Method** section.
- 7 From the list, choose **Nitsche**.
- 8 In the **Label** text field, type Contact (Seal-Seal).

### *Friction 1*

- 1 In the **Physics** toolbar, click  **Attributes** and choose **Friction**.
- 2 In the **Settings** window for **Friction**, locate the **Friction Parameters** section.

3 In the  $\mu$  text field, type 0.8.

#### *Symmetry I*

- 1 In the **Physics** toolbar, click  **Boundaries** and choose **Symmetry**.
- 2 Select Boundaries 1, 3, 7, 12, 15, 20, 23, 28, 33, 36, 39, 45, and 103–114 only.



#### *Fixed Constraint I*

- 1 In the **Physics** toolbar, click  **Boundaries** and choose **Fixed Constraint**.
- 2 Select Boundaries 9 and 100 only.

#### *Roller I*

- 1 In the **Physics** toolbar, click  **Boundaries** and choose **Roller**.
- 2 Select Boundaries 11 and 99 only.

### **ADD MATERIAL**

- 1 In the **Materials** toolbar, click  **Add Material** to open the **Add Material** window.
- 2 Go to the **Add Material** window.
- 3 In the tree, select **Built-in > Rubber**.
- 4 Click the **Add to Component** button in the window toolbar.
- 5 In the **Materials** toolbar, click  **Add Material** to close the **Add Material** window.

### **MESH I**

#### *Mapped I*

- 1 In the **Mesh** toolbar, click  **More Generators** and choose **Mapped**.
- 2 Select Boundaries 1, 3, 7, 12, 15, 20, 23, 28, 33, 36, 39, 45, 126, 128, 132, 135, 138, 141, and 142 only.

#### *Size I*

- 1 Right-click **Mapped I** and choose **Size**.
- 2 In the **Settings** window for **Size**, locate the **Element Size** section.
- 3 Click the **Custom** button.
- 4 Locate the **Element Size Parameters** section.
- 5 Select the **Maximum element size** checkbox. In the associated text field, type 5.

#### *Distribution I*

- 1 In the **Model Builder** window, right-click **Mapped I** and choose **Distribution**.
- 2 In the **Settings** window for **Distribution**, locate the **Distribution** section.

- 3 In the **Number of elements** text field, type 2.
- 4 Select Edges 6, 8, 16, 18, 26, 28, 34, 36, 44, 46, 51, 59, 62, and 246 only.

#### *Distribution 2*

- 1 Right-click **Mapped 1** and choose **Distribution**.
- 2 In the **Settings** window for **Distribution**, locate the **Distribution** section.
- 3 In the **Number of elements** text field, type 6.
- 4 Select Edges 20, 30, 38, and 53 only.

#### *Mapped 2*

- 1 In the **Mesh** toolbar, click  **More Generators** and choose **Mapped**.
- 2 Select Boundary 115 only.

#### *Distribution 1*

- 1 Right-click **Mapped 2** and choose **Distribution**.
- 2 In the **Settings** window for **Distribution**, locate the **Edge Selection** section.
- 3 From the **Selection** list, choose **All edges**.
- 4 Locate the **Distribution** section. In the **Number of elements** text field, type 1.

#### *Swept 1*

- 1 In the **Mesh** toolbar, click  **Swept**.
- 2 In the **Settings** window for **Swept**, click to expand the **Control Entities** section.
- 3 From the **Smooth across removed control entities** list, choose **Off**.



#### *Distribution 1*

- 1 Right-click **Swept 1** and choose **Distribution**.
- 2 In the **Settings** window for **Distribution**, locate the **Distribution** section.
- 3 From the **Distribution type** list, choose **Predefined**.
- 4 In the **Number of elements** text field, type 16.
- 5 In the **Element ratio** text field, type 3.

#### *Distribution 2*

- 1 Right-click **Distribution 1** and choose **Duplicate**.
- 2 Select Domains 13–24 and 36–40 only.
- 3 In the **Settings** window for **Distribution**, locate the **Distribution** section.
- 4 Select the **Reverse direction** checkbox.

### Distribution 3

- 1 In the **Model Builder** window, right-click **Swept 1** and choose **Distribution**.
- 2 In the **Settings** window for **Distribution**, locate the **Domain Selection** section.
- 3 Click  **Clear Selection**.
- 4 Select Domains 25 and 26 only.
- 5 Locate the **Distribution** section. In the **Number of elements** text field, type 25.
- 6 Click  **Build All**.

### STUDY 1



#### Step 1: Stationary

- 1 In the **Model Builder** window, under **Study 1** click **Step 1: Stationary**.
- 2 In the **Settings** window for **Stationary**, click to expand the **Results While Solving** section.
- 3 Select the **Plot** checkbox.
- 4 From the **Update at** list, choose **Steps taken by solver**.  
Incrementally remove the contact surface offset so that the shrink fit is created in the first study step using para1.
- 5 Click to expand the **Study Extensions** section. Select the **Auxiliary sweep** checkbox.
- 6 Click  **Add**.
- 7 In the table, enter the following settings:

Parameter name	Parameter value list	Parameter unit
para1 (Continuation parameter, step 1)	0 1	

Add a second study step where the pipe is rotated using para2 while para1 is kept constant.

#### Step 2: Stationary 2

- 1 In the **Study** toolbar, click  **Stationary**.
- 2 In the **Settings** window for **Stationary**, locate the **Results While Solving** section.
- 3 Select the **Plot** checkbox.
- 4 From the **Update at** list, choose **Steps taken by solver**.
- 5 Locate the **Study Extensions** section. Select the **Auxiliary sweep** checkbox.
- 6 Click  **Add**.

7 In the table, enter the following settings:

Parameter name	Parameter value list	Parameter unit
para1 (Continuation parameter, step 1)	1	

8 Click  **Add**.

9 In the table, enter the following settings:

Parameter name	Parameter value list	Parameter unit
para2 (Continuation parameter, step 2)	range(0,0.1,1)	

10 From the **Sweep type** list, choose **All combinations**.

The robustness and performance of the solution can be improved by making some modifications to the default solver.

#### *Solution 1 (sol1)*

- 1 In the **Study** toolbar, click  **Show Default Solver**.
- 2 In the **Model Builder** window, expand the **Solution 1 (sol1)** node.
- 3 In the **Model Builder** window, expand the **Study 1 > Solver Configurations > Solution 1 (sol1) > Dependent Variables 1** node, then click **Auxiliary Pressure (comp1.solid.hmm1.pw)**.
- 4 In the **Settings** window for **Field**, locate the **Scaling** section.
- 5 In the **Scale** text field, type  $1e5$ .
- 6 In the **Model Builder** window, expand the **Study 1 > Solver Configurations > Solution 1 (sol1) > Stationary Solver 1** node, then click **Parametric 1**.
- 7 In the **Settings** window for **Parametric**, click to expand the **Continuation** section.
- 8 Select the **Tuning of step size** checkbox.
- 9 In the **Maximum step size** text field, type  $0.5$ .
- 10 In the **Model Builder** window, under **Study 1 > Solver Configurations > Solution 1 (sol1) > Stationary Solver 1** click **Fully Coupled 1**.
- 11 In the **Settings** window for **Fully Coupled**, click to expand the **Method and Termination** section.
- 12 From the **Nonlinear method** list, choose **Constant (Newton)**.
- 13 In the **Maximum number of iterations** text field, type  $8$ .

- 14 In the **Model Builder** window, expand the **Study 1 > Solver Configurations > Solution 1 (sol1) > Stationary Solver 2** node.
- 15 In the **Model Builder** window, expand the **Study 1 > Solver Configurations > Solution 1 (sol1) > Dependent Variables 2** node, then click **Auxiliary Pressure (comp1.solid.hmm1.pw)**.
- 16 In the **Settings** window for **Field**, locate the **Scaling** section.
- 17 In the **Scale** text field, type 1e5.
- 18 In the **Model Builder** window, under **Study 1 > Solver Configurations > Solution 1 (sol1) > Stationary Solver 2** click **Parametric 1**.
- 19 In the **Settings** window for **Parametric**, locate the **Continuation** section.
- 20 Select the **Tuning of step size** checkbox.
- 21 In the **Initial step size** text field, type 0.005.
- 22 In the **Maximum step size** text field, type 0.025.
- 23 In the **Model Builder** window, under **Study 1 > Solver Configurations > Solution 1 (sol1) > Stationary Solver 2** click **Fully Coupled 1**.
- 24 In the **Settings** window for **Fully Coupled**, locate the **Method and Termination** section.
- 25 From the **Nonlinear method** list, choose **Constant (Newton)**.
- 26 In the **Maximum number of iterations** text field, type 8.
- 27 In the **Study** toolbar, click  **Compute**.

## RESULTS

### *Stress (solid)*

Click the  **Go to Default View** button in the **Graphics** toolbar.

### *Volume 1*

- 1 In the **Model Builder** window, expand the **Stress (solid)** node, then click **Volume 1**.
- 2 In the **Settings** window for **Volume**, locate the **Expression** section.
- 3 From the **Unit** list, choose **MPa**.
- 4 In the **Stress (solid)** toolbar, click  **Plot**.

Plot the deformed boot seal at different solution parameters.

### *Mirror 3D 1*

- 1 In the **Results** toolbar, click  **More Datasets** and choose **Mirror 3D**.
- 2 In the **Settings** window for **Mirror 3D**, locate the **Plane Data** section.

- 3 From the **Plane** list, choose **ZX-planes**.

#### *Displacement*

- 1 In the **Results** toolbar, click  **3D Plot Group**.
- 2 In the **Settings** window for **3D Plot Group**, type Displacement in the **Label** text field.
- 3 Click to expand the **Title** section. From the **Title type** list, choose **None**.
- 4 Locate the **Plot Settings** section. Clear the **Plot dataset edges** checkbox.
- 5 Click to expand the **Plot Array** section. From the **Array type** list, choose **Square**.
- 6 From the **Array plane** list, choose **xz**.

#### *Surface 1*

- 1 Right-click **Displacement** and choose **Surface**.
- 2 In the **Settings** window for **Surface**, locate the **Coloring and Style** section.
- 3 From the **Color table** list, choose **SpectrumLight**.
- 4 Locate the **Data** section. From the **Dataset** list, choose **Mirror 3D 1**.

#### *Deformation 1*

- 1 Right-click **Surface 1** and choose **Deformation**.
- 2 In the **Settings** window for **Deformation**, locate the **Scale** section.
- 3 Select the **Scale factor** checkbox. In the associated text field, type 1.

#### *Solution Array 1*

- 1 In the **Model Builder** window, right-click **Surface 1** and choose **Solution Array**.
- 2 In the **Settings** window for **Solution Array**, locate the **Data** section.
- 3 From the **Parameter selection (para2)** list, choose **From list**.
- 4 In the **Parameter values (para2)** list, choose **0, 0.2, 0.4, 0.6, 0.8, and 1**.
- 5 Locate the **Plot Array** section. From the **Array shape** list, choose **Square**.
- 6 In the **Displacement** toolbar, click  **Plot**.

#### *Contact Area*

- 1 In the **Results** toolbar, click  **3D Plot Group**.  
Create a plot highlighting boundaries that are in contact.
- 2 In the **Settings** window for **3D Plot Group**, type Contact Area in the **Label** text field.
- 3 Locate the **Title** section. From the **Title type** list, choose **None**.
- 4 Locate the **Plot Settings** section. From the **Frame** list, choose **Spatial (x, y, z)**.

### *Surface 1*

- 1 Right-click **Contact Area** and choose **Surface**.
- 2 In the **Settings** window for **Surface**, locate the **Expression** section.
- 3 In the **Expression** text field, type `if (elemgmax(8, solid.incontact), 1, NaN)`.
- 4 Locate the **Coloring and Style** section. From the **Coloring** list, choose **Uniform**.

### *Deformation 1*

- 1 Right-click **Surface 1** and choose **Deformation**.
- 2 In the **Settings** window for **Deformation**, locate the **Scale** section.
- 3 Select the **Scale factor** checkbox. In the associated text field, type 1.

### *Selection 1*

- 1 In the **Model Builder** window, right-click **Surface 1** and choose **Selection**.
- 2 In the **Settings** window for **Selection**, locate the **Selection** section.
- 3 From the **Geometric entity level** list, choose **Domain**.
- 4 Select Domains 1–24 only.

### *Surface 2*

- 1 In the **Model Builder** window, right-click **Contact Area** and choose **Surface**.
- 2 In the **Settings** window for **Surface**, locate the **Expression** section.
- 3 In the **Expression** text field, type 1.
- 4 Locate the **Coloring and Style** section. From the **Coloring** list, choose **Uniform**.
- 5 From the **Color** list, choose **Gray**.

### *Deformation 1*

- 1 Right-click **Surface 2** and choose **Deformation**.
- 2 In the **Settings** window for **Deformation**, locate the **Scale** section.
- 3 Select the **Scale factor** checkbox. In the associated text field, type 1.

### *Transparency 1*

- 1 In the **Model Builder** window, right-click **Surface 2** and choose **Transparency**.
- 2 In the **Settings** window for **Transparency**, locate the **Transparency** section.
- 3 Find the **Transparency** subsection. In the **Transparency** text field, type 0.8.
- 4 Find the **Fresnel transmittance** subsection. In the **Fresnel transmittance** text field, type 0.2.
- 5 In the **Contact Area** toolbar, click  **Plot**.

## Appendix — Geometry Modeling Instructions



---

From the **File** menu, choose **New**.

### NEW

In the **New** window, click  **Model Wizard**.

### MODEL WIZARD

- 1 In the **Model Wizard** window, click  **3D**.
- 2 Click  **Done**.

### GEOMETRY I

- 1 In the **Model Builder** window, under **Component 1 (comp1)** click **Geometry 1**.
- 2 In the **Settings** window for **Geometry**, locate the **Units** section.
- 3 From the **Length unit** list, choose **mm**.

#### Work Plane 1 (wp1)

- 1 In the **Geometry** toolbar, click  **Work Plane**.
- 2 In the **Settings** window for **Work Plane**, locate the **Plane Definition** section.
- 3 From the **Plane** list, choose **yz-plane**.

#### Work Plane 1 (wp1) > Plane Geometry

In the **Model Builder** window, click **Plane Geometry**.

#### Work Plane 1 (wp1) > Polygon 1 (pol1)

- 1 In the **Work Plane** toolbar, click  **Polygon**.
- 2 In the **Settings** window for **Polygon**, locate the **Object Type** section.
- 3 From the **Type** list, choose **Open curve**.
- 4 Locate the **Coordinates** section. In the table, enter the following settings:

xw (mm)	yw (mm)
100	20
100	0

#### Work Plane 1 (wp1) > Quadratic Bézier 1 (qb1)

- 1 In the **Work Plane** toolbar, click  **More Primitives** and choose **Quadratic Bézier**.
- 2 In the **Settings** window for **Quadratic Bézier**, locate the **Control Points** section.

- 3 In row 1, set **xw** to 100.
- 4 In row 1, set **yw** to 20.
- 5 In row 2, set **xw** to 110.
- 6 In row 2, set **yw** to 35.
- 7 In row 3, set **xw** to 110.
- 8 In row 3, set **yw** to 45.

*Work Plane 1 (wp1) > Quadratic Bézier 2 (qb2)*

- 1 In the **Work Plane** toolbar, click  **More Primitives** and choose **Quadratic Bézier**.
- 2 In the **Settings** window for **Quadratic Bézier**, locate the **Control Points** section.
- 3 In row 1, set **xw** to 110.
- 4 In row 1, set **yw** to 45.
- 5 In row 2, set **xw** to 110.
- 6 In row 2, set **yw** to 52.
- 7 In row 3, set **xw** to 90.
- 8 In row 3, set **yw** to 55.

*Work Plane 1 (wp1) > Circular Arc 1 (ca1)*

- 1 In the **Work Plane** toolbar, click  **More Primitives** and choose **Circular Arc**.
- 2 In the **Settings** window for **Circular Arc**, locate the **Properties** section.
- 3 From the **Specify** list, choose **Endpoints and start angle**.
- 4 Locate the **Starting Point** section. In the **xw** text field, type 90.
- 5 In the **yw** text field, type 55.
- 6 Locate the **Endpoint** section. In the **xw** text field, type 90.
- 7 In the **yw** text field, type 58.
- 8 Locate the **Angles** section. In the **Start angle** text field, type -55.
- 9 Select the **Clockwise** checkbox.

*Work Plane 1 (wp1) > Quadratic Bézier 3 (qb3)*

- 1 In the **Work Plane** toolbar, click  **More Primitives** and choose **Quadratic Bézier**.
- 2 In the **Settings** window for **Quadratic Bézier**, locate the **Control Points** section.
- 3 In row 1, set **xw** to 90.
- 4 In row 1, set **yw** to 58.
- 5 In row 2, set **xw** to 110.

- 6 In row 2, set **yw** to 65.
- 7 In row 3, set **xw** to 110.
- 8 In row 3, set **yw** to 73.

*Work Plane 1 (wp1) > Quadratic Bézier 4 (qb4)*

- 1 In the **Work Plane** toolbar, click  **More Primitives** and choose **Quadratic Bézier**.
- 2 In the **Settings** window for **Quadratic Bézier**, locate the **Control Points** section.
- 3 In row 1, set **xw** to 110.
- 4 In row 1, set **yw** to 73.
- 5 In row 2, set **xw** to 110.
- 6 In row 2, set **yw** to 80.
- 7 In row 3, set **xw** to 76.
- 8 In row 3, set **yw** to 85.

*Work Plane 1 (wp1) > Circular Arc 2 (ca2)*

- 1 In the **Work Plane** toolbar, click  **More Primitives** and choose **Circular Arc**.
- 2 In the **Settings** window for **Circular Arc**, locate the **Properties** section.
- 3 From the **Specify** list, choose **Endpoints and start angle**.
- 4 Locate the **Starting Point** section. In the **xw** text field, type 76.
- 5 In the **yw** text field, type 85.
- 6 Locate the **Endpoint** section. In the **xw** text field, type 76.
- 7 In the **yw** text field, type 88.
- 8 Locate the **Angles** section. In the **Start angle** text field, type -55.
- 9 Select the **Clockwise** checkbox.

*Work Plane 1 (wp1) > Copy 1 (copy1)*

- 1 In the **Work Plane** toolbar, click  **Transforms** and choose **Copy**.
- 2 Select the objects **ca2**, **qb3**, and **qb4** only.
- 3 In the **Settings** window for **Copy**, locate the **Displacement** section.
- 4 In the **xw** text field, type -14 -28.
- 5 In the **yw** text field, type 30 60.

*Work Plane 1 (wp1) > Quadratic Bézier 5 (qb5)*

- 1 In the **Work Plane** toolbar, click  **More Primitives** and choose **Quadratic Bézier**.
- 2 In the **Settings** window for **Quadratic Bézier**, locate the **Control Points** section.

- 3 In row 1, set **xw** to 48.
- 4 In row 1, set **yw** to 148.
- 5 In row 2, set **xw** to 58.
- 6 In row 2, set **yw** to 150.
- 7 In row 3, set **xw** to 58.
- 8 In row 3, set **yw** to 164.

*Work Plane 1 (wp1) > Quadratic Bézier 6 (qb6)*

- 1 In the **Work Plane** toolbar, click  **More Primitives** and choose **Quadratic Bézier**.
- 2 In the **Settings** window for **Quadratic Bézier**, locate the **Control Points** section.
- 3 In row 1, set **xw** to 58.
- 4 In row 1, set **yw** to 164.
- 5 In row 2, set **xw** to 58.
- 6 In row 2, set **yw** to 174.
- 7 In row 3, set **xw** to 48.
- 8 In row 3, set **yw** to 174.

*Work Plane 1 (wp1) > Quadratic Bézier 7 (qb7)*

- 1 In the **Work Plane** toolbar, click  **More Primitives** and choose **Quadratic Bézier**.
- 2 In the **Settings** window for **Quadratic Bézier**, locate the **Control Points** section.
- 3 In row 1, set **xw** to 48.
- 4 In row 1, set **yw** to 174.
- 5 In row 2, set **xw** to 30.
- 6 In row 2, set **yw** to 174.
- 7 In row 3, set **xw** to 30.
- 8 In row 3, set **yw** to 195.

*Work Plane 1 (wp1) > Polygon 2 (pol2)*

- 1 In the **Work Plane** toolbar, click  **Polygon**.
- 2 In the **Settings** window for **Polygon**, locate the **Object Type** section.
- 3 From the **Type** list, choose **Open curve**.

4 Locate the **Coordinates** section. In the table, enter the following settings:

xw (mm)	yw (mm)
30	195
30	225

*Work Plane 1 (wp1) > Union 1 (uni1)*

- 1 In the **Work Plane** toolbar, click  **Booleans and Partitions** and choose **Union**.
- 2 Click in the **Graphics** window and then press Ctrl+A to select all objects.

*Work Plane 1 (wp1) > Thicken 1 (thi1)*

- 1 In the **Work Plane** toolbar, click  **Conversions** and choose **Thicken**.
- 2 Select the object **uni1** only.
- 3 In the **Settings** window for **Thicken**, locate the **Options** section.
- 4 From the **Offset** list, choose **Asymmetric**.
- 5 In the **Upside thickness** text field, type 3.

*Work Plane 1 (wp1) > Fillet 1 (fil1)*

- 1 In the **Work Plane** toolbar, click  **Fillet**.
- 2 On the object **thi1**, select Points 21, 28, 36, and 37 only.
- 3 In the **Settings** window for **Fillet**, locate the **Radius** section.
- 4 In the **Radius** text field, type 1.

*Work Plane 1 (wp1) > Fillet 2 (fil2)*

- 1 In the **Work Plane** toolbar, click  **Fillet**.
- 2 On the object **fil1**, select Points 5, 6, 9, 10, 13–20, 25–28, and 37 only.
- 3 In the **Settings** window for **Fillet**, locate the **Radius** section.
- 4 In the **Radius** text field, type 1.5.



*Work Plane 1 (wp1) > Rectangle 1 (r1)*

- 1 In the **Work Plane** toolbar, click  **Rectangle**.
- 2 In the **Settings** window for **Rectangle**, locate the **Size and Shape** section.
- 3 In the **Width** text field, type 5.
- 4 In the **Height** text field, type 5.
- 5 Locate the **Position** section. In the **xw** text field, type 27.
- 6 In the **yw** text field, type 220.



*Work Plane 1 (wp1) > Plane Geometry*

Partition the domain to facilitate better control of the mesh.



*Work Plane 1 (wp1) > Line Segment 1 (ls1)*

- 1 In the **Work Plane** toolbar, click  **More Primitives** and choose **Line Segment**.
- 2 On the object **fil2**, select Point 50 only.
- 3 In the **Settings** window for **Line Segment**, locate the **Endpoint** section.
- 4 Click to select the  **Activate Selection** toggle button for **End vertex**.
- 5 On the object **fil2**, select Point 53 only.
- 6 Click  **Build Selected**.

*Work Plane 1 (wp1) > Line Segment 2 (ls2)*



- 1 Right-click **Component 1 (comp1) > Geometry 1 > Work Plane 1 (wp1) > Plane Geometry > Line Segment 1 (ls1)** and choose **Duplicate**.
- 2 In the **Settings** window for **Line Segment**, locate the **Starting Point** section.
- 3 Click to select the  **Activate Selection** toggle button for **Start vertex**.
- 4 On the object **fil2**, select Point 51 only.
- 5 Locate the **Endpoint** section. Click to select the  **Activate Selection** toggle button for **End vertex**.
- 6 On the object **fil2**, select Point 54 only.
- 7 Click  **Build Selected**.

*Work Plane 1 (wp1) > Line Segment 3 (ls3)*



- 1 Right-click **Component 1 (comp1) > Geometry 1 > Work Plane 1 (wp1) > Plane Geometry > Line Segment 2 (ls2)** and choose **Duplicate**.
- 2 In the **Settings** window for **Line Segment**, locate the **Starting Point** section.
- 3 Click to select the  **Activate Selection** toggle button for **Start vertex**.
- 4 On the object **fil2**, select Point 58 only.
- 5 Locate the **Endpoint** section. Click to select the  **Activate Selection** toggle button for **End vertex**.
- 6 On the object **fil2**, select Point 61 only.
- 7 Click  **Build Selected**.

*Work Plane 1 (wp1) > Line Segment 4 (ls4)*



- 1 Right-click **Component 1 (comp1) > Geometry 1 > Work Plane 1 (wp1) > Plane Geometry > Line Segment 3 (ls3)** and choose **Duplicate**.

- 2 In the **Settings** window for **Line Segment**, locate the **Starting Point** section.
- 3 Click to select the  **Activate Selection** toggle button for **Start vertex**.
- 4 On the object **fil2**, select Point 57 only.
- 5 Locate the **Endpoint** section. Click to select the  **Activate Selection** toggle button for **End vertex**.
- 6 On the object **fil2**, select Point 60 only.
- 7 Click  **Build Selected**.

*Work Plane 1 (wp1) > Line Segment 5 (ls5)*



- 1 Right-click **Component 1 (comp1) > Geometry 1 > Work Plane 1 (wp1) > Plane Geometry > Line Segment 4 (ls4)** and choose **Duplicate**.
- 2 In the **Settings** window for **Line Segment**, locate the **Starting Point** section.
- 3 Click to select the  **Activate Selection** toggle button for **Start vertex**.
- 4 On the object **fil2**, select Point 44 only.
- 5 Locate the **Endpoint** section. Click to select the  **Activate Selection** toggle button for **End vertex**.
- 6 On the object **fil2**, select Point 42 only.
- 7 Click  **Build Selected**.

*Work Plane 1 (wp1) > Line Segment 6 (ls6)*



- 1 Right-click **Component 1 (comp1) > Geometry 1 > Work Plane 1 (wp1) > Plane Geometry > Line Segment 5 (ls5)** and choose **Duplicate**.
- 2 In the **Settings** window for **Line Segment**, locate the **Starting Point** section.
- 3 Click to select the  **Activate Selection** toggle button for **Start vertex**.
- 4 On the object **fil2**, select Point 40 only.
- 5 Locate the **Endpoint** section. Click to select the  **Activate Selection** toggle button for **End vertex**.
- 6 On the object **fil2**, select Point 38 only.
- 7 Click  **Build Selected**.

*Work Plane 1 (wp1) > Line Segment 7 (ls7)*



- 1 Right-click **Component 1 (comp1) > Geometry 1 > Work Plane 1 (wp1) > Plane Geometry > Line Segment 6 (ls6)** and choose **Duplicate**.
- 2 In the **Settings** window for **Line Segment**, locate the **Starting Point** section.
- 3 Click to select the  **Activate Selection** toggle button for **Start vertex**.

- 4 On the object **fil2**, select Point 39 only.
- 5 Locate the **Endpoint** section. Click to select the  **Activate Selection** toggle button for **End vertex**.
- 6 On the object **fil2**, select Point 37 only.
- 7 Click  **Build Selected**.

*Work Plane 1 (wp1) > Line Segment 8 (ls8)*



- 1 Right-click **Component 1 (comp1) > Geometry 1 > Work Plane 1 (wp1) > Plane Geometry > Line Segment 7 (ls7)** and choose **Duplicate**.
- 2 In the **Settings** window for **Line Segment**, locate the **Starting Point** section.
- 3 Click to select the  **Activate Selection** toggle button for **Start vertex**.
- 4 On the object **fil2**, select Point 41 only.
- 5 Locate the **Endpoint** section. Click to select the  **Activate Selection** toggle button for **End vertex**.
- 6 On the object **fil2**, select Point 43 only.
- 7 Click  **Build Selected**.

*Work Plane 1 (wp1) > Line Segment 9 (ls9)*



- 1 Right-click **Component 1 (comp1) > Geometry 1 > Work Plane 1 (wp1) > Plane Geometry > Line Segment 8 (ls8)** and choose **Duplicate**.
- 2 In the **Settings** window for **Line Segment**, locate the **Starting Point** section.
- 3 Click to select the  **Activate Selection** toggle button for **Start vertex**.
- 4 On the object **fil2**, select Point 56 only.
- 5 Locate the **Endpoint** section. Click to select the  **Activate Selection** toggle button for **End vertex**.
- 6 On the object **fil2**, select Point 62 only.
- 7 Click  **Build Selected**.

*Work Plane 1 (wp1) > Line Segment 10 (ls10)*



- 1 Right-click **Component 1 (comp1) > Geometry 1 > Work Plane 1 (wp1) > Plane Geometry > Line Segment 9 (ls9)** and choose **Duplicate**.
- 2 In the **Settings** window for **Line Segment**, locate the **Starting Point** section.
- 3 Click to select the  **Activate Selection** toggle button for **Start vertex**.
- 4 On the object **fil2**, select Point 55 only.

- 5 Locate the **Endpoint** section. Click to select the  **Activate Selection** toggle button for **End vertex**.
- 6 On the object **fil2**, select Point 59 only.
- 7 Click  **Build Selected**.



*Work Plane 1 (wp1) > Line Segment 11 (ls11)*

- 1 Right-click **Component 1 (comp1) > Geometry 1 > Work Plane 1 (wp1) > Plane Geometry > Line Segment 10 (ls10)** and choose **Duplicate**.
- 2 In the **Settings** window for **Line Segment**, locate the **Starting Point** section.
- 3 Click to select the  **Activate Selection** toggle button for **Start vertex**.
- 4 On the object **fil2**, select Point 32 only.
- 5 Locate the **Endpoint** section. Click to select the  **Activate Selection** toggle button for **End vertex**.
- 6 On the object **fil2**, select Point 30 only.
- 7 Click  **Build Selected**.

*Work Plane 1 (wp1) > Line Segment 12 (ls12)*

- 1 Right-click **Component 1 (comp1) > Geometry 1 > Work Plane 1 (wp1) > Plane Geometry > Line Segment 11 (ls11)** and choose **Duplicate**.
- 2 In the **Settings** window for **Line Segment**, locate the **Starting Point** section.
- 3 Click to select the  **Activate Selection** toggle button for **Start vertex**.
- 4 On the object **fil2**, select Point 28 only.
- 5 Locate the **Endpoint** section. Click to select the  **Activate Selection** toggle button for **End vertex**.
- 6 On the object **fil2**, select Point 26 only.
- 7 Click  **Build Selected**.

*Work Plane 1 (wp1) > Line Segment 13 (ls13)*

- 1 Right-click **Component 1 (comp1) > Geometry 1 > Work Plane 1 (wp1) > Plane Geometry > Line Segment 12 (ls12)** and choose **Duplicate**.
- 2 In the **Settings** window for **Line Segment**, locate the **Starting Point** section.
- 3 Click to select the  **Activate Selection** toggle button for **Start vertex**.
- 4 On the object **fil2**, select Point 27 only.
- 5 Locate the **Endpoint** section. Click to select the  **Activate Selection** toggle button for **End vertex**.

6 On the object **fil2**, select Point 25 only.

7 Click  **Build Selected**.

*Work Plane 1 (wp1) > Line Segment 14 (ls14)*

1 Right-click **Component 1 (comp1) > Geometry 1 > Work Plane 1 (wp1) > Plane Geometry > Line Segment 13 (ls13)** and choose **Duplicate**.

2 In the **Settings** window for **Line Segment**, locate the **Starting Point** section.

3 Click to select the  **Activate Selection** toggle button for **Start vertex**.

4 On the object **fil2**, select Point 29 only.

5 Locate the **Endpoint** section. Click to select the  **Activate Selection** toggle button for **End vertex**.

6 On the object **fil2**, select Point 31 only.

7 Click  **Build Selected**.

*Work Plane 1 (wp1) > Line Segment 15 (ls15)*

1 Right-click **Component 1 (comp1) > Geometry 1 > Work Plane 1 (wp1) > Plane Geometry > Line Segment 14 (ls14)** and choose **Duplicate**.

2 In the **Settings** window for **Line Segment**, locate the **Starting Point** section.

3 Click to select the  **Activate Selection** toggle button for **Start vertex**.

4 On the object **fil2**, select Point 46 only.

5 Locate the **Endpoint** section. Click to select the  **Activate Selection** toggle button for **End vertex**.

6 On the object **fil2**, select Point 48 only.

7 Click  **Build Selected**.

*Work Plane 1 (wp1) > Line Segment 16 (ls16)*

1 Right-click **Component 1 (comp1) > Geometry 1 > Work Plane 1 (wp1) > Plane Geometry > Line Segment 15 (ls15)** and choose **Duplicate**.

2 In the **Settings** window for **Line Segment**, locate the **Starting Point** section.

3 Click to select the  **Activate Selection** toggle button for **Start vertex**.



4 On the object **fil2**, select Point 45 only.

5 Locate the **Endpoint** section. Click to select the  **Activate Selection** toggle button for **End vertex**.



6 On the object **fil2**, select Point 47 only.

7 Click  **Build Selected**.



*Work Plane 1 (wp1) > Line Segment 17 (ls17)*

- 1 Right-click **Component 1 (comp1) > Geometry 1 > Work Plane 1 (wp1) > Plane Geometry > Line Segment 16 (ls16)** and choose **Duplicate**.
- 2 In the **Settings** window for **Line Segment**, locate the **Starting Point** section.
- 3 Click to select the  **Activate Selection** toggle button for **Start vertex**.
- 4 On the object **fil2**, select Point 24 only.
- 5 Locate the **Endpoint** section. Click to select the  **Activate Selection** toggle button for **End vertex**.
- 6 On the object **fil2**, select Point 22 only.
- 7 Click  **Build Selected**.

*Work Plane 1 (wp1) > Line Segment 18 (ls18)*



- 1 Right-click **Component 1 (comp1) > Geometry 1 > Work Plane 1 (wp1) > Plane Geometry > Line Segment 17 (ls17)** and choose **Duplicate**.
- 2 In the **Settings** window for **Line Segment**, locate the **Starting Point** section.
- 3 Click to select the  **Activate Selection** toggle button for **Start vertex**.
- 4 On the object **fil2**, select Point 20 only.
- 5 Locate the **Endpoint** section. Click to select the  **Activate Selection** toggle button for **End vertex**.
- 6 On the object **fil2**, select Point 18 only.
- 7 Click  **Build Selected**.

*Work Plane 1 (wp1) > Line Segment 19 (ls19)*



- 1 Right-click **Component 1 (comp1) > Geometry 1 > Work Plane 1 (wp1) > Plane Geometry > Line Segment 18 (ls18)** and choose **Duplicate**.
- 2 In the **Settings** window for **Line Segment**, locate the **Starting Point** section.
- 3 Click to select the  **Activate Selection** toggle button for **Start vertex**.
- 4 On the object **fil2**, select Point 19 only.
- 5 Locate the **Endpoint** section. Click to select the  **Activate Selection** toggle button for **End vertex**.
- 6 On the object **fil2**, select Point 17 only.
- 7 Click  **Build Selected**.

*Work Plane 1 (wp1) > Line Segment 20 (ls20)*



- 1 Right-click **Component 1 (comp1) > Geometry 1 > Work Plane 1 (wp1) > Plane Geometry > Line Segment 19 (ls19)** and choose **Duplicate**.

- 2 In the **Settings** window for **Line Segment**, locate the **Starting Point** section.
- 3 Click to select the  **Activate Selection** toggle button for **Start vertex**.
- 4 On the object **fil2**, select Point 21 only.
- 5 Locate the **Endpoint** section. Click to select the  **Activate Selection** toggle button for **End vertex**.
- 6 On the object **fil2**, select Point 23 only.
- 7 Click  **Build Selected**.

*Work Plane 1 (wp1) > Line Segment 21 (ls21)*



- 1 Right-click **Component 1 (comp1) > Geometry 1 > Work Plane 1 (wp1) > Plane Geometry > Line Segment 20 (ls20)** and choose **Duplicate**.
- 2 In the **Settings** window for **Line Segment**, locate the **Starting Point** section.
- 3 Click to select the  **Activate Selection** toggle button for **Start vertex**.
- 4 On the object **fil2**, select Point 34 only.
- 5 Locate the **Endpoint** section. Click to select the  **Activate Selection** toggle button for **End vertex**.
- 6 On the object **fil2**, select Point 36 only.
- 7 Click  **Build Selected**.

*Work Plane 1 (wp1) > Line Segment 22 (ls22)*



- 1 Right-click **Component 1 (comp1) > Geometry 1 > Work Plane 1 (wp1) > Plane Geometry > Line Segment 21 (ls21)** and choose **Duplicate**.
- 2 In the **Settings** window for **Line Segment**, locate the **Starting Point** section.
- 3 Click to select the  **Activate Selection** toggle button for **Start vertex**.
- 4 On the object **fil2**, select Point 33 only.
- 5 Locate the **Endpoint** section. Click to select the  **Activate Selection** toggle button for **End vertex**.
- 6 On the object **fil2**, select Point 35 only.
- 7 Click  **Build Selected**.

*Work Plane 1 (wp1) > Line Segment 23 (ls23)*



- 1 Right-click **Component 1 (comp1) > Geometry 1 > Work Plane 1 (wp1) > Plane Geometry > Line Segment 22 (ls22)** and choose **Duplicate**.
- 2 In the **Settings** window for **Line Segment**, locate the **Starting Point** section.
- 3 Click to select the  **Activate Selection** toggle button for **Start vertex**.

- 4 On the object **fil2**, select Point 14 only.
- 5 Locate the **Endpoint** section. Click to select the  **Activate Selection** toggle button for **End vertex**.
- 6 On the object **fil2**, select Point 11 only.
- 7 Click  **Build Selected**.

*Work Plane 1 (wp1) > Line Segment 24 (ls24)*



- 1 Right-click **Component 1 (comp1) > Geometry 1 > Work Plane 1 (wp1) > Plane Geometry > Line Segment 23 (ls23)** and choose **Duplicate**.
- 2 In the **Settings** window for **Line Segment**, locate the **Starting Point** section.
- 3 Click to select the  **Activate Selection** toggle button for **Start vertex**.
- 4 On the object **fil2**, select Point 10 only.
- 5 Locate the **Endpoint** section. Click to select the  **Activate Selection** toggle button for **End vertex**.
- 6 On the object **fil2**, select Point 6 only.
- 7 Click  **Build Selected**.

*Work Plane 1 (wp1) > Line Segment 25 (ls25)*



- 1 Right-click **Component 1 (comp1) > Geometry 1 > Work Plane 1 (wp1) > Plane Geometry > Line Segment 24 (ls24)** and choose **Duplicate**.
- 2 In the **Settings** window for **Line Segment**, locate the **Starting Point** section.
- 3 Click to select the  **Activate Selection** toggle button for **Start vertex**.
- 4 On the object **fil2**, select Point 7 only.
- 5 Locate the **Endpoint** section. Click to select the  **Activate Selection** toggle button for **End vertex**.
- 6 On the object **fil2**, select Point 5 only.
- 7 Click  **Build Selected**.

*Work Plane 1 (wp1) > Line Segment 26 (ls26)*



- 1 Right-click **Component 1 (comp1) > Geometry 1 > Work Plane 1 (wp1) > Plane Geometry > Line Segment 25 (ls25)** and choose **Duplicate**.
- 2 In the **Settings** window for **Line Segment**, locate the **Starting Point** section.
- 3 Click to select the  **Activate Selection** toggle button for **Start vertex**.
- 4 On the object **fil2**, select Point 13 only.

- 5 Locate the **Endpoint** section. Click to select the  **Activate Selection** toggle button for **End vertex**.
- 6 On the object **fil2**, select Point 12 only.
- 7 Click  **Build Selected**.



*Work Plane 1 (wp1) > Line Segment 27 (ls27)*

- 1 Right-click **Component 1 (comp1) > Geometry 1 > Work Plane 1 (wp1) > Plane Geometry > Line Segment 26 (ls26)** and choose **Duplicate**.
- 2 In the **Settings** window for **Line Segment**, locate the **Starting Point** section.
- 3 Click to select the  **Activate Selection** toggle button for **Start vertex**.
- 4 On the object **fil2**, select Point 15 only.
- 5 Locate the **Endpoint** section. Click to select the  **Activate Selection** toggle button for **End vertex**.
- 6 On the object **fil2**, select Point 16 only.
- 7 Click  **Build Selected**.

*Work Plane 1 (wp1) > Line Segment 28 (ls28)*

- 1 Right-click **Component 1 (comp1) > Geometry 1 > Work Plane 1 (wp1) > Plane Geometry > Line Segment 27 (ls27)** and choose **Duplicate**.
- 2 In the **Settings** window for **Line Segment**, locate the **Starting Point** section.
- 3 Click to select the  **Activate Selection** toggle button for **Start vertex**.
- 4 On the object **fil2**, select Point 8 only.
- 5 Locate the **Endpoint** section. Click to select the  **Activate Selection** toggle button for **End vertex**.
- 6 On the object **fil2**, select Point 9 only.
- 7 Click  **Build Selected**.

*Work Plane 1 (wp1) > Line Segment 29 (ls29)*

- 1 Right-click **Component 1 (comp1) > Geometry 1 > Work Plane 1 (wp1) > Plane Geometry > Line Segment 28 (ls28)** and choose **Duplicate**.
- 2 In the **Settings** window for **Line Segment**, locate the **Starting Point** section.
- 3 Click to select the  **Activate Selection** toggle button for **Start vertex**.
- 4 On the object **fil2**, select Point 1 only.
- 5 Locate the **Endpoint** section. Click to select the  **Activate Selection** toggle button for **End vertex**.

6 On the object **fil2**, select Point 3 only.

7 Click  **Build Selected**.

*Work Plane 1 (wp1) > Line Segment 1 (ls1), Work Plane 1 (wp1) > Line Segment 10 (ls10), Work Plane 1 (wp1) > Line Segment 11 (ls11), Work Plane 1 (wp1) > Line Segment 12 (ls12), Work Plane 1 (wp1) > Line Segment 13 (ls13), Work Plane 1 (wp1) > Line Segment 14 (ls14), Work Plane 1 (wp1) > Line Segment 15 (ls15), Work Plane 1 (wp1) > Line Segment 16 (ls16), Work Plane 1 (wp1) > Line Segment 17 (ls17), Work Plane 1 (wp1) > Line Segment 18 (ls18), Work Plane 1 (wp1) > Line Segment 19 (ls19), Work Plane 1 (wp1) > Line Segment 2 (ls2), Work Plane 1 (wp1) > Line Segment 20 (ls20), Work Plane 1 (wp1) > Line Segment 21 (ls21), Work Plane 1 (wp1) > Line Segment 22 (ls22), Work Plane 1 (wp1) > Line Segment 23 (ls23), Work Plane 1 (wp1) > Line Segment 24 (ls24), Work Plane 1 (wp1) > Line Segment 25 (ls25), Work Plane 1 (wp1) > Line Segment 26 (ls26), Work Plane 1 (wp1) > Line Segment 27 (ls27), Work Plane 1 (wp1) > Line Segment 28 (ls28), Work Plane 1 (wp1) > Line Segment 29 (ls29), Work Plane 1 (wp1) > Line Segment 3 (ls3), Work Plane 1 (wp1) > Line Segment 4 (ls4), Work Plane 1 (wp1) > Line Segment 5 (ls5), Work Plane 1 (wp1) > Line Segment 6 (ls6), Work Plane 1 (wp1) > Line Segment 7 (ls7), Work Plane 1 (wp1) > Line Segment 8 (ls8), Work Plane 1 (wp1) > Line Segment 9 (ls9)*

1 In the **Model Builder** window, under **Component 1 (comp1) > Geometry 1 > Work Plane 1 (wp1) > Plane Geometry**, Ctrl-click to select **Line Segment 1 (ls1), Line Segment 2 (ls2), Line Segment 3 (ls3), Line Segment 4 (ls4), Line Segment 5 (ls5), Line Segment 6 (ls6), Line Segment 7 (ls7), Line Segment 8 (ls8), Line Segment 9 (ls9), Line Segment 10 (ls10), Line Segment 11 (ls11), Line Segment 12 (ls12), Line Segment 13 (ls13), Line Segment 14 (ls14), Line Segment 15 (ls15), Line Segment 16 (ls16), Line Segment 17 (ls17), Line Segment 18 (ls18), Line Segment 19 (ls19), Line Segment 20 (ls20), Line Segment 21 (ls21), Line Segment 22 (ls22), Line Segment 23 (ls23), Line Segment 24 (ls24), Line Segment 25 (ls25), Line Segment 26 (ls26), Line Segment 27 (ls27), Line Segment 28 (ls28), and Line Segment 29 (ls29)**.

2 Right-click and choose **Group**.

#### *Partition Objects*

In the **Settings** window for **Group**, type **Partition Objects** in the **Label** text field.

#### *Revolve 1 (rev1)*

1 In the **Model Builder** window, under **Component 1 (comp1) > Geometry 1** right-click **Work Plane 1 (wp1)** and choose **Revolve**.

2 In the **Settings** window for **Revolve**, locate the **Revolution Angles** section.

- 3 Click the **Angles** button.
- 4 In the **Start angle** text field, type -90.
- 5 In the **End angle** text field, type 90.

*Partition Objects I (parI)*

- 1 In the **Geometry** toolbar, click  **Booleans and Partitions** and choose **Partition Objects**.
- 2 Select the object **revI** only.
- 3 In the **Settings** window for **Partition Objects**, locate the **Partition Objects** section.
- 4 From the **Partition with** list, choose **Work plane**.

*Cylinder I (cylI)*

- 1 In the **Geometry** toolbar, click  **Cylinder**.
- 2 In the **Settings** window for **Cylinder**, locate the **Size and Shape** section.
- 3 In the **Radius** text field, type (60) / 2-3.
- 4 In the **Height** text field, type 275.
- 5 Locate the **Position** section. In the **z** text field, type -10.
- 6 Click to expand the **Layers** section. In the table, enter the following settings:

Layer name	Thickness (mm)
Layer 1	3

*Delete Entities I (delI)*

- 1 In the **Model Builder** window, right-click **Geometry I** and choose **Delete Entities**.
- 2 In the **Settings** window for **Delete Entities**, locate the **Entities or Objects to Delete** section.
- 3 From the **Geometric entity level** list, choose **Domain**.
- 4 On the object **cylI**, select Domains 1, 3, and 4 only.

*Form Union (fin)*



- 1 In the **Model Builder** window, under **Component I (compI) > Geometry I** click **Form Union (fin)**.
- 2 In the **Settings** window for **Form Union/Assembly**, locate the **Form Union/Assembly** section.
- 3 From the **Action** list, choose **Form an assembly**.
- 4 Clear the **Create pairs** checkbox.

*Ignore Faces I (igfl)*

- 1 In the **Geometry** toolbar, click  **Virtual Operations** and choose **Ignore Faces**.

- 2 On the object **fin**, select Boundaries 12, 15, 25, 38, 44, 47, 62, 68, 71, 81, 84, 101, 104, 162, 165, 182, 185, 201, 204, 210, 225, 228, 234, 244, 251, and 255 only.

*Mesh Control Faces I (mcfI)*

- 1 In the **Geometry** toolbar, click  **Virtual Operations** and choose **Mesh Control Faces**.
- 2 On the object **igfl**, select Boundaries 4, 9, 23, 35, 51, 73, 74, 85, 90, 109, 132, 144, 153, and 154 only.
- 3 In the **Settings** window for **Mesh Control Faces**, click  **Build Selected**.