



Model created in COMSOL Multiphysics 6.4

Polynomial Hyperelastic Model

Introduction

This example shows how you can implement a user-defined hyperelastic material using the strain energy density function. The implemented model is a general Mooney–Rivlin hyperelastic material model defined by a polynomial.

For such a material model, the strain energy density function has the following expression:

$$W = \sum_{i,j=0}^n C_{i,j} (\bar{I}_1 - 3)^i (\bar{I}_2 - 3)^j + \frac{1}{2} K (J_{e1} - 1)^2$$

Here \bar{I}_1 and \bar{I}_2 are the first and second invariant of the left isochoric Cauchy–Green deformation tensor, J_{e1} is the elastic Jacobian, $C_{i,j}$ are coefficients in the polynomial, and K is the bulk modulus.

In this example, you implement two material models based on the above expression: a two-parameter equation and a five-parameter equation. The two-parameter Mooney–Rivlin material model implementation is then validated with the results obtained with the built-in Mooney–Rivlin hyperelastic material.

Model Definition

A simple geometry is used consisting of a single block of the hyperelastic material as shown in [Figure 1](#). The block is fixed at one face and loaded with a uniform normal load of 1 MPa at the opposite face. Due to symmetry, only one quarter of the geometry is represented.

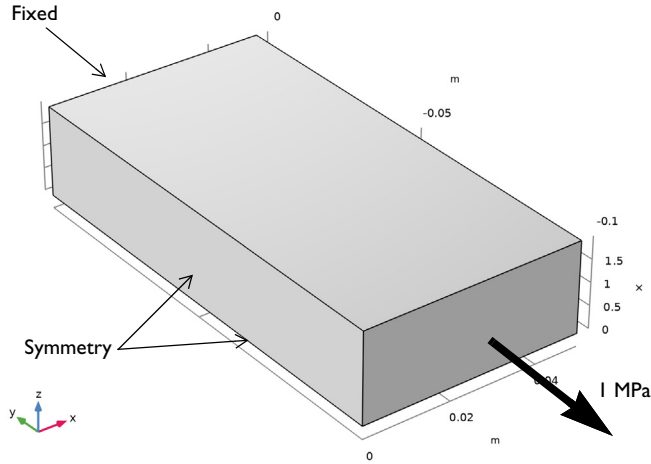

Figure 1: Model geometry with boundary conditions and loads.

The two-parameter Mooney–Rivlin material model is defined by the following strain energy density:

$$W_{\text{iso}} = C_{1,0}(\bar{I}_1 - 3) + C_{0,1}(\bar{I}_2 - 3)$$

$$W_{\text{svol}} = \frac{1}{2}\kappa(J_{\text{el}} - 1)^2$$

The five-parameter Mooney–Rivlin material model is defined by the following strain energy density:

$$W_{\text{iso}} = \begin{cases} C_{1,0}(\bar{I}_1 - 3) + C_{0,1}(\bar{I}_2 - 3) + C_{2,0}(\bar{I}_1 - 3)^2 + \\ C_{0,2}(\bar{I}_2 - 3)^2 + C_{1,1}(\bar{I}_1 - 3)(\bar{I}_2 - 3) \end{cases}$$

$$W_{\text{svol}} = \frac{1}{2}\kappa(J_{\text{el}} - 1)^2$$

Note: Both the two parameter and the five parameter Mooney-Rivlin material model are available in the **Hyperelastic Material** node.

Results and Discussion

Figure 2 shows the y -component of the second Piola–Kirchhoff stress along the center axis of the block. You can see that the results from the two parameter polynomial equation model perfectly matches the results of the built-in Mooney–Rivlin material.

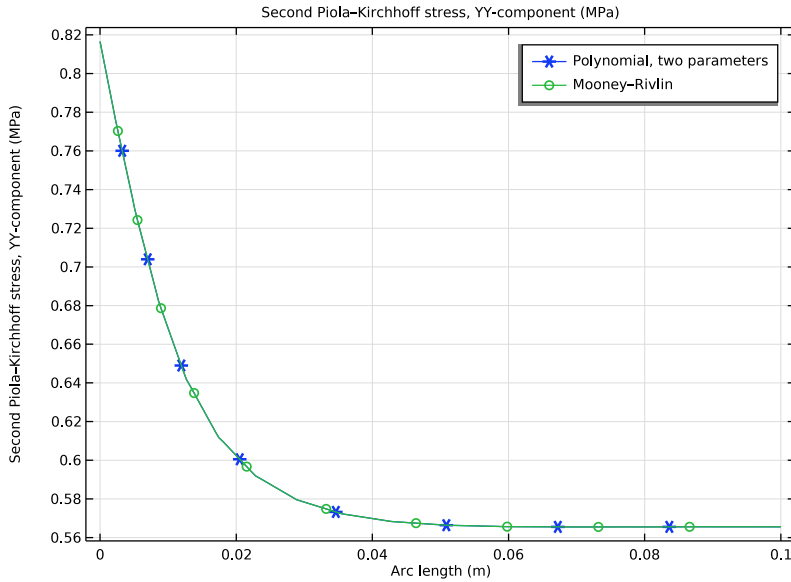

Figure 2: Stress plot (y -component of the second Piola–Kirchhoff stress) along the length of the block.

Figure 3 shows the von Mises stress distribution in the geometry obtained with the two parameter Mooney–Rivlin material. Figure 4 shows the von Mises stress distribution in the geometry with the five parameter Mooney–Rivlin material model. Note the difference in deformation: the five parameter polynomial model has a significantly smaller deformation than the two parameter model

For the five parameter material, you can see that the stress in the region far away from the fixed end is significantly lower than for the two parameter material. This is because the area reduction is much larger with the more flexible two parameter material, although, the total load is the same in both cases. The von Mises stress is computed from the Cauchy stress, which is based on force per current area.

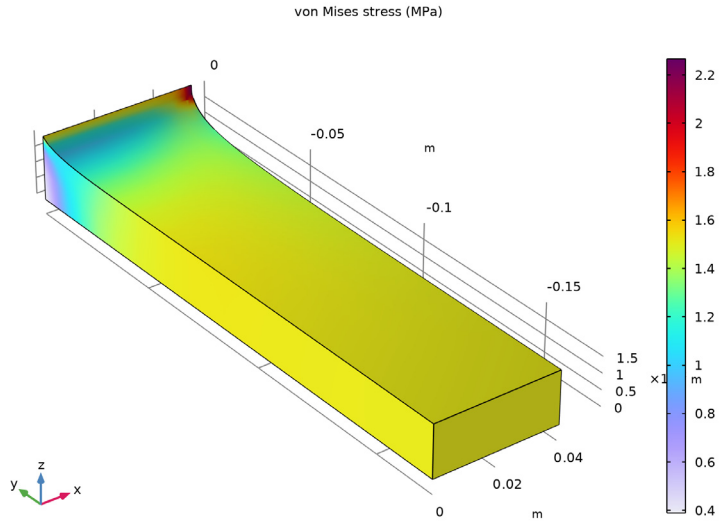

Figure 3: Distribution of the von Mises stress for the two-parameter polynomial hyperelastic material model.

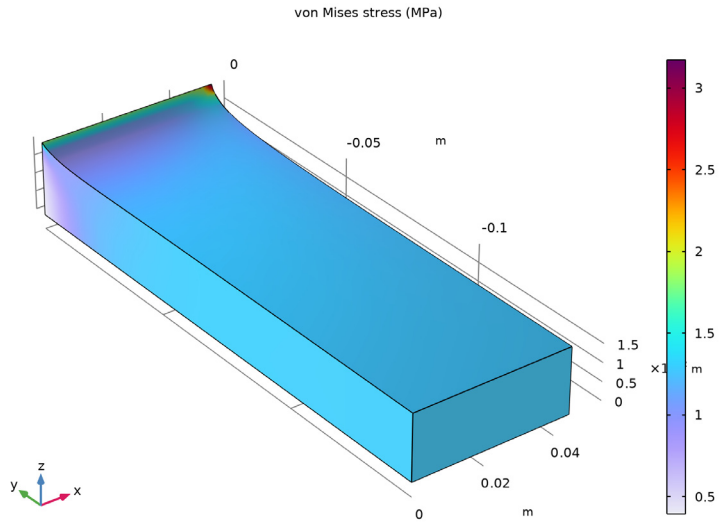

Figure 4: Distribution of the von Mises stress for the five-parameter polynomial hyperelastic material model.

Notes About the COMSOL Implementation

Instead of using the predefined hyperelastic material model, you manually define the material in the **Hyperelastic Material** node's **Settings** window. In the Hyperelastic Material section, select **User defined** from the **Material model** list.

For nearly incompressible materials, the strain energy density is defined using a separation of the isochoric strain energy density and the volumetric strain energy density.

When you use a hyperelastic material in your model, all studies automatically become geometrically nonlinear.

Application Library path: Nonlinear_Structural_Materials_Module/
Hyperelasticity/polynomial_hyperelastic



Modeling Instructions

From the **File** menu, choose **New**.

NEW

In the **New** window, click  **Model Wizard**.

MODEL WIZARD

- 1 In the **Model Wizard** window, click  **3D**.
- 2 In the **Select Physics** tree, select **Structural Mechanics > Solid Mechanics (solid)**.
- 3 Click **Add**.
- 4 Click  **Study**.
- 5 In the **Select Study** tree, select **General Studies > Stationary**.
- 6 Click  **Done**.

GLOBAL DEFINITIONS

Parameters 1



- 1 In the **Model Builder** window, under **Global Definitions** click **Parameters 1**.
- 2 In the **Settings** window for **Parameters**, locate the **Parameters** section.

3 In the table, enter the following settings:

Name	Expression	Value	Description
kappa	3[MPa]	3E6 Pa	Bulk modulus
C01	0.5[MPa]	5E5 Pa	Polynomial coefficient C01
C10	0.1[MPa]	1E5 Pa	Polynomial coefficient C10
C11	0.15[MPa]	1.5E5 Pa	Polynomial coefficient C11
C20	0.2[MPa]	2E5 Pa	Polynomial coefficient C20
C02	-0.2[MPa]	-2E5 Pa	Polynomial coefficient C02

GEOMETRY I

Block 1 (blk1)

- 1 In the **Geometry** toolbar, click  **Block**.
- 2 In the **Settings** window for **Block**, locate the **Size and Shape** section.
- 3 In the **Width** text field, type 0.1.
- 4 In the **Depth** text field, type 0.05.
- 5 In the **Height** text field, type 0.02.
- 6 Locate the **Rotation Angle** section. In the **Rotation** text field, type -90.
- 7 Click  **Build All Objects**.
- 8 Click the  **Zoom Extents** button in the **Graphics** toolbar.

DEFINITIONS

Variables 1

- 1 In the **Definitions** toolbar, click  **Local Variables**.
- 2 In the **Settings** window for **Variables**, locate the **Variables** section.

3 In the table, enter the following settings:

Name	Expression	Unit	Description
Wsiso_MR2	$C10*(\text{solid.I1CIeI-3})+C01*(\text{solid.I2CIeI-3})$	Pa	Isochoric strain energy density, Mooney-Rivlin two parameters
Wsiso_MR5	$W\text{siso_MR2}+C20*(\text{solid.I1CIeI-3})^2+C02*(\text{solid.I2CIeI-3})^2+C11*(\text{solid.I1CIeI-3})*(\text{solid.I2CIeI-3})$	Pa	Isochoric strain energy density, Mooney-Rivlin five parameters
Wsvol	$0.5*\kappa*(\text{solid.JeI-1})^2$	Pa	Volumetric strain energy density

SOLID MECHANICS (SOLID)

Fixed Constraint 1

- 1 In the **Physics** toolbar, click  **Boundaries** and choose **Fixed Constraint**.
- 2 Select Boundary 5 only.

Symmetry 1

- 1 In the **Physics** toolbar, click  **Boundaries** and choose **Symmetry**.
- 2 Select Boundaries 1 and 3 only.

Boundary Load 1

- 1 In the **Physics** toolbar, click  **Boundaries** and choose **Boundary Load**.
- 2 Select Boundary 2 only.
- 3 In the **Settings** window for **Boundary Load**, locate the **Force** section.
- 4 Specify the \mathbf{f}_A vector as

0	x
-1 [MPa]	y
0	z

TWO PARAMETER POLYNOMIAL HYPERELASTIC MATERIAL MODEL

Polynomial, Two Parameters

- 1 In the **Physics** toolbar, click  **Domains** and choose **Hyperelastic Material**.
- 2 In the **Settings** window for **Hyperelastic Material**, type Polynomial, Two Parameters in the **Label** text field.

- 3 Locate the **Domain Selection** section. From the **Selection** list, choose **All domains**.
- 4 Locate the **Hyperelastic Material** section. From the **Material model** list, choose **User defined**.
- 5 From the **Compressibility** list, choose **Nearly incompressible**.
- 6 In the W_{siso} text field, type `Wsiso_MR2`.
- 7 In the W_{svol} text field, type `Wsvol1`.

MESH I

Mapped I

- 1 In the **Mesh** toolbar, click  **More Generators** and choose **Mapped**.
- 2 Select Boundary 5 only.

Distribution I

- 1 Right-click **Mapped I** and choose **Distribution**.
- 2 Select Edges 6 and 12 only.
- 3 In the **Settings** window for **Distribution**, locate the **Distribution** section.
- 4 From the **Distribution type** list, choose **Predefined**.
- 5 In the **Number of elements** text field, type 4.
- 6 In the **Element ratio** text field, type 5.
- 7 Select the **Reverse direction** checkbox.

Distribution 2

- 1 In the **Model Builder** window, right-click **Mapped I** and choose **Distribution**.
- 2 Select Edges 7 and 8 only.
- 3 In the **Settings** window for **Distribution**, locate the **Distribution** section.
- 4 From the **Distribution type** list, choose **Predefined**.
- 5 In the **Number of elements** text field, type 6.
- 6 In the **Element ratio** text field, type 5.

Swept I

In the **Mesh** toolbar, click  **Swept**.

Distribution I

- 1 Right-click **Swept I** and choose **Distribution**.
- 2 In the **Settings** window for **Distribution**, locate the **Distribution** section.
- 3 From the **Distribution type** list, choose **Predefined**.

- 4 In the **Number of elements** text field, type 15.
- 5 In the **Element ratio** text field, type 5.
- 6 Click  **Build All**.

MOONEY–RIVLIN HYPERELASTIC MATERIAL MODEL

Mooney–Rivlin

- 1 In the **Physics** toolbar, click  **Domains** and choose **Hyperelastic Material**.
- 2 In the **Settings** window for **Hyperelastic Material**, type Mooney-Rivlin in the **Label** text field.
- 3 Locate the **Domain Selection** section. From the **Selection** list, choose **All domains**.
- 4 Locate the **Hyperelastic Material** section. From the **Material model** list, choose **Mooney–Rivlin, two parameters**.
- 5 From the C_{10} list, choose **User defined**. In the associated text field, type C10.
- 6 From the C_{01} list, choose **User defined**. In the associated text field, type C01.
- 7 In the κ text field, type kappa.

Polynomial, Five Parameters

- 1 In the **Model Builder** window, right-click **Polynomial, Two Parameters** and choose **Duplicate**.
- 2 In the **Settings** window for **Hyperelastic Material**, type Polynomial, Five Parameters in the **Label** text field.
- 3 Locate the **Hyperelastic Material** section. In the W_{siso} text field, type Wsiso_MR5.

The five parameter Mooney–Rivlin material is also available as predefined hyperelastic material.



First solve the two parameter polynomial model.

STUDY: POLYNOMIAL, TWO PARAMETERS

- 1 In the **Model Builder** window, click **Study 1**.
- 2 In the **Settings** window for **Study**, type Study: Polynomial, Two Parameters in the **Label** text field.



Step 1: Stationary

- 1 In the **Model Builder** window, under **Study: Polynomial, Two Parameters** click **Step 1: Stationary**.
- 2 In the **Settings** window for **Stationary**, locate the **Physics and Variables Selection** section.

- 3 Select the **Modify model configuration for study step** checkbox.
- 4 In the tree, select **Component 1 (comp1) > Solid Mechanics (solid), Controls spatial frame > Mooney–Rivlin** and **Component 1 (comp1) > Solid Mechanics (solid), Controls spatial frame > Polynomial, Five Parameters**.
- 5 Click  **Disable**.
- 6 In the **Study** toolbar, click  **Compute**.

RESULTS

Preferred Units 1

- 1 In the **Results** toolbar, click  **Configurations** and choose **Preferred Units**.
- 2 In the **Settings** window for **Preferred Units**, locate the **Units** section.
- 3 Click  **Add Physical Quantity**.
- 4 In the **Physical Quantity** dialog, select **Solid Mechanics > Stress tensor (N/m²)** in the tree.
- 5 Click **OK**.
- 6 In the **Settings** window for **Preferred Units**, locate the **Units** section.
- 7 In the table, enter the following settings:



Quantity	Unit	Preferred unit
Stress tensor	N/m ²	MPa

- 8 Click  **Apply**.

Stress (Polynomial, Two Parameters)

- 1 In the **Model Builder** window, under **Results** click **Stress (solid)**.
- 2 In the **Settings** window for **3D Plot Group**, type **Stress (Polynomial, Two Parameters)** in the **Label** text field.

Volume 1

- 1 In the **Model Builder** window, expand the **Stress (Polynomial, Two Parameters)** node, then click **Volume 1**.
- 2 In the **Stress (Polynomial, Two Parameters)** toolbar, click  **Plot**.
- 3 Click the  **Go to Default View** button in the **Graphics** toolbar.



Volume Maximum 1

- 1 In the **Results** toolbar, click  **More Derived Values** and choose **Maximum > Volume Maximum**.
- 2 In the **Settings** window for **Volume Maximum**, locate the **Selection** section.

- 3 From the **Selection** list, choose **All domains**.
- 4 Click **Replace Expression** in the upper-right corner of the **Expressions** section. From the menu, choose **Component 1 (comp1) > Solid Mechanics > Displacement > Displacement field - m > v - Displacement field, Y-component**.
- 5 Click to expand the **Configuration** section. From the **Find maximum of** list, choose **Absolute value**.
- 6 Click  **Evaluate**.



Now solve the Mooney–Rivlin model.

ADD STUDY

- 1 In the **Home** toolbar, click  **Add Study** to open the **Add Study** window.
- 2 Go to the **Add Study** window.
- 3 Find the **Studies** subsection. In the **Select Study** tree, select **General Studies > Stationary**.
- 4 Click the **Add Study** button in the window toolbar.
- 5 In the **Home** toolbar, click  **Add Study** to close the **Add Study** window.

STUDY 2

Step 1: Stationary

- 1 In the **Settings** window for **Stationary**, locate the **Physics and Variables Selection** section.
- 2 Select the **Modify model configuration for study step** checkbox.
- 3 In the tree, select **Component 1 (comp1) > Solid Mechanics (solid), Controls spatial frame > Polynomial, Five Parameters**.
- 4 Click  **Disable**.
- 5 In the **Model Builder** window, click **Study 2**.
- 6 In the **Settings** window for **Study**, type Study: Mooney-Rivlin in the **Label** text field.
- 7 In the **Study** toolbar, click  **Compute**.



RESULTS

Stress (Mooney–Rivlin)

In the **Settings** window for **3D Plot Group**, type Stress (Mooney-Rivlin) in the **Label** text field.

Volume 1

- 1 In the **Model Builder** window, expand the **Stress (Mooney–Rivlin)** node, then click **Volume 1**.



- 2 In the **Stress (Mooney–Rivlin)** toolbar, click  **Plot**.
- 3 Click the  **Go to Default View** button in the **Graphics** toolbar.

Volume Maximum I

- 1 In the **Model Builder** window, under **Results** > **Derived Values** click **Volume Maximum I**.
- 2 In the **Settings** window for **Volume Maximum**, locate the **Data** section.
- 3 From the **Dataset** list, choose **Study: Mooney–Rivlin/Solution 2 (sol2)**.
- 4 Click  **Evaluate**.

Now solve the five parameter polynomial model.

ADD STUDY

- 1 In the **Home** toolbar, click  **Add Study** to open the **Add Study** window.
- 2 Go to the **Add Study** window.
- 3 Find the **Studies** subsection. In the **Select Study** tree, select **General Studies** > **Stationary**.
- 4 Click the **Add Study** button in the window toolbar.
- 5 In the **Home** toolbar, click  **Add Study** to close the **Add Study** window.

STUDY: POLYNOMIAL, FIVE PARAMETERS



- 1 In the **Settings** window for **Study**, type Study: Polynomial, Five Parameters in the **Label** text field.
- 2 In the **Study** toolbar, click  **Compute**.

RESULTS

Stress (Polynomial, Five Parameters)

In the **Settings** window for **3D Plot Group**, type Stress (Polynomial, Five Parameters) in the **Label** text field.

Volume I

- 1 In the **Model Builder** window, expand the **Stress (Polynomial, Five Parameters)** node, then click **Volume I**.
- 2 In the **Stress (Polynomial, Five Parameters)** toolbar, click  **Plot**.
- 3 Click the  **Go to Default View** button in the **Graphics** toolbar.

Volume Maximum I

- 1 In the **Model Builder** window, under **Results** > **Derived Values** click **Volume Maximum I**.
- 2 In the **Settings** window for **Volume Maximum**, locate the **Data** section.

3 From the **Dataset** list, choose **Study: Polynomial, Five Parameters/Solution 3 (sol3)**.

4 Click  **Evaluate**.

To compare the results of the two parameter polynomial model with Mooney–Rivlin results, reproduce [Figure 2](#).

Second Piola–Kirchhoff Stress

1 In the **Results** toolbar, click  **ID Plot Group**.

2 In the **Settings** window for **ID Plot Group**, type Second Piola–Kirchhoff Stress in the **Label** text field.

Line Graph 1

1 In the **Second Piola–Kirchhoff Stress** toolbar, click  **Line Graph**.

2 Select Edge 2 only.

3 In the **Settings** window for **Line Graph**, click **Replace Expression** in the upper-right corner of the **y-Axis Data** section. From the menu, choose **Component 1 (comp1) > Solid Mechanics > Stress > Second Piola–Kirchhoff stress (material and geometry frames) - N/m² > solid.SGpYY - Second Piola–Kirchhoff stress, YY-component**.

4 Click to expand the **Coloring and Style** section. Find the **Line markers** subsection. From the **Marker** list, choose **Cycle**.

5 From the **Positioning** list, choose **Interpolated**.

6 Click to expand the **Legends** section. Select the **Show legends** checkbox.

7 From the **Legends** list, choose **Manual**.

8 In the table, enter the following settings:

Legends
Polynomial, two parameters

Line Graph 2

1 Right-click **Line Graph 1** and choose **Duplicate**.

2 In the **Settings** window for **Line Graph**, locate the **Data** section.

3 From the **Dataset** list, choose **Study: Mooney–Rivlin/Solution 2 (sol2)**.

4 Locate the **Coloring and Style** section. Find the **Line markers** subsection. In the **Number** text field, type 10.

5 Locate the **Legends** section. In the table, enter the following settings:

Legends

Mooney-Rivlin

6 Click to expand the **Title** section. From the **Title type** list, choose **None**.

7 In the **Second Piola–Kirchhoff Stress** toolbar, click  **Plot**.