



Model created in COMSOL Multiphysics 6.4

Crimping of a Cable Terminal

Introduction

Crimping is the plastic deformation process used to form an electrical and mechanical connection between a stranded conductor and a terminal. The process involves complex multi-surface contact, including self contact, as the terminal sleeve is plastically deformed around the wire strands. This example analyzes the crimping of an aviation wire terminal using an explicit dynamics simulation. The problem is inspired by [Ref. 1](#).

Model Definition

This example analyzes the formation of a crimp joint between a cylindrical terminal and a stranded conductor composed of 19 individual wire strands. The geometry is shown in [Figure 1](#). Compaction is achieved by pressing the cylindrical sleeve against the wires using four rigid indenters. Both the terminal and the wires are modeled as elastoplastic materials

with linear isotropic hardening. The material properties, summarized in Table 1, are selected to be representative of copper alloys.

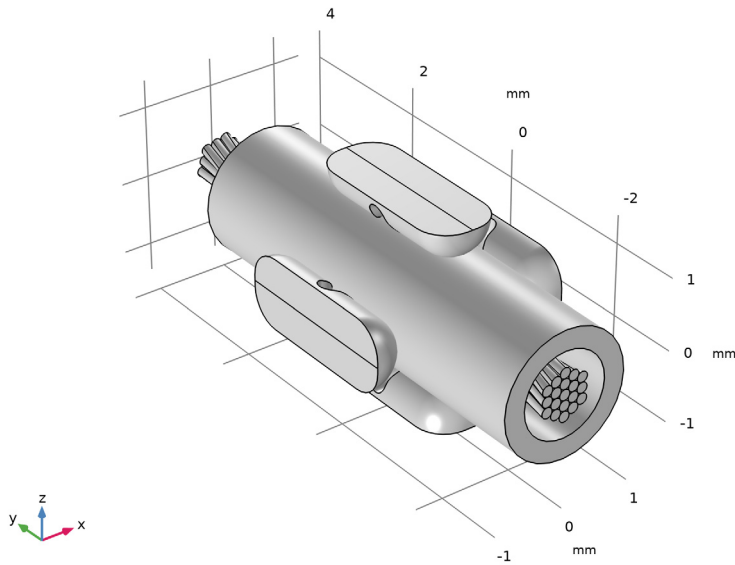

Figure 1: Geometry of the undeformed crimp joint formation assembly.

TABLE 1: MATERIAL PARAMETERS.

Material parameter	Wires	Terminal	Indenters
Density	8.96 g/cm ³	8.3 g/cm ³	8 g/cm ³
Young's modulus	130 GPa	135 GPa	200 GPa
Poisson's ratio	0.34	0.35	0.3
Yield strength	90 MPa	480 MPa	N/A
Tangent modulus	370 MPa	285 MPa	N/A

Results and Discussion

Figure 2 shows the residual von Mises stress in the deformed crimp joint after unloading. A detailed view of the stress distribution in a cross section is displayed in Figure 3. This close-up illustrates the complex contact conditions that develop between individual wires, between the terminal and the wires, and due to self-contact arising from folding at the corners of the initially cylindrical terminal sleeve.

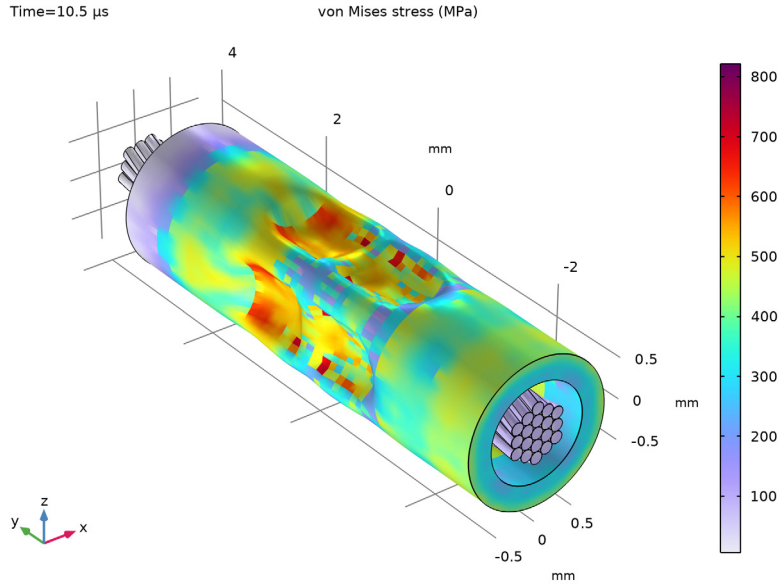

Figure 2: von Mises stress in the assembly after completion of the crimp joint formation.

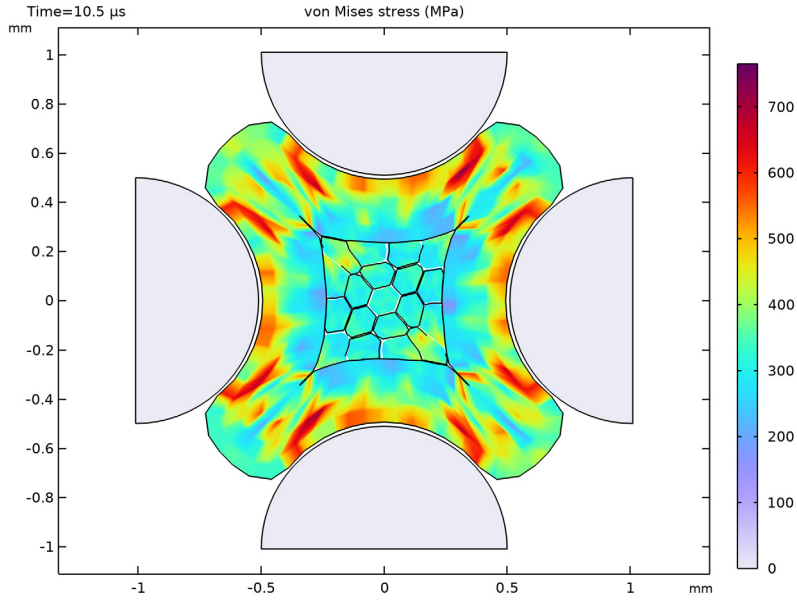

Figure 3: von Mises stress distribution in a cross section of the crimp joint.

The equivalent plastic strain for the same cross section is shown in [Figure 4](#) at several selected time points. The top-right snapshot corresponds to the cross section after unloading and indicates minimal elastic snap-back, an expected outcome given the extreme plastic deformations.

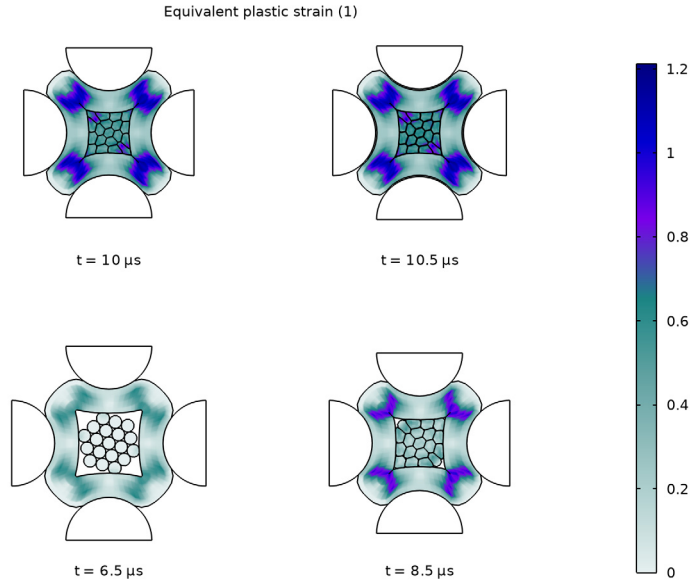

Figure 4: Necking development in the midsection.

The reaction force measured on one of the indenters is plotted in [Figure 5](#). At the end of the crimping process, a retraction of the indenter by 0.025 mm is sufficient to achieve complete detachment.

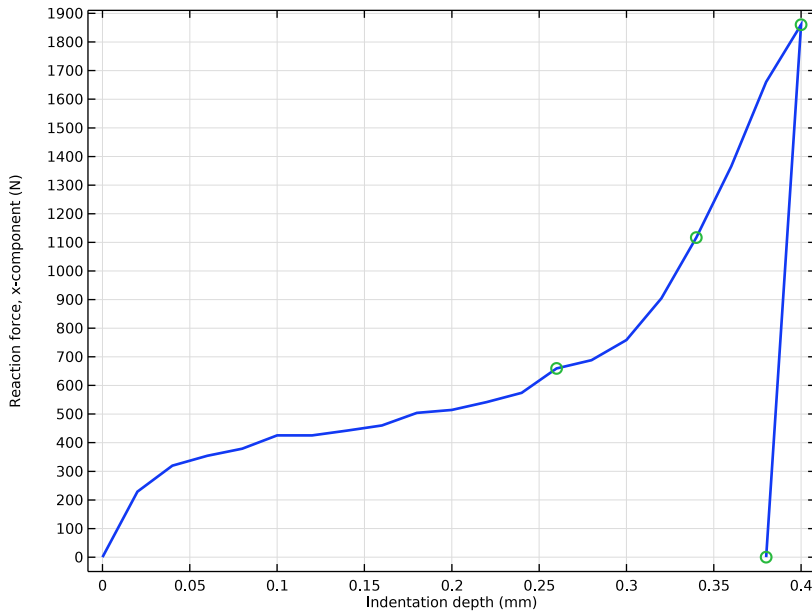

Figure 5: Reaction force measured on one of the indenters. The green circles correspond to the time points visualized in Figure 4.

Figure 6 shows a comparison between the most important energy measures during the crimping process. For a nearly quasistatic process like crimping, it is important to verify that the inertial effects are small compared to the elastic and dissipated energy in the materials. As the previous results indicate, the dominant contribution in this case is the energy dissipation due to plastic deformation. The kinetic energy stays well below 5% of the elastic and dissipated energy, while the hourglass stabilization energy accounts for approximately 8% of that.

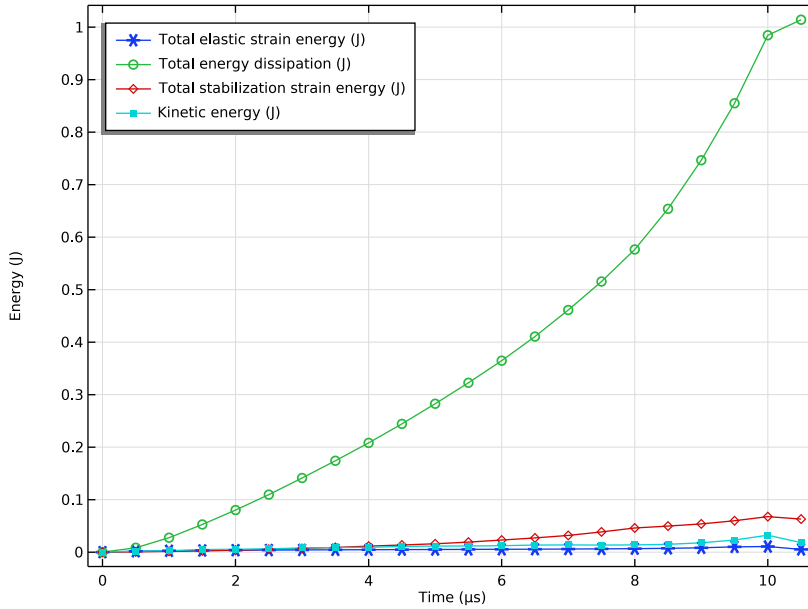

Figure 6: Elastic strain energy, dissipated energy, hourglass stabilization energy, and kinetic energy in the crimp joint during the formation process.

Notes About the COMSOL Implementation

Crimping represents a highly nonlinear problem that is typically slow enough to be considered as quasistatic. However, the nonlinearities introduced by large plastic deformations and contact makes such a problem challenging for implicit solvers. By increasing the indenter speed while ensuring that the inertial effects stay small, these problems can be solved more efficiently using explicit solvers.

Reference

1. P. Li, G. Liu, P. Wang, G. Huang, Z. Yu, H. Xiu, and C. Tian, “Numerical and experimental study on the relationship between pull-out force and indentation depth of aviation wire crimp terminal,” *Sci. Rep.*, vol. 12, 21939, 2022.

Application Library path: Nonlinear_Structural_Materials_Module/
Plasticity/cable_crimping



Modeling Instructions

From the **File** menu, choose **New**.

NEW

In the **New** window, click  **Model Wizard**.

MODEL WIZARD

- 1 In the **Model Wizard** window, click  **3D**.
- 2 In the **Select Physics** tree, select **Structural Mechanics > Explicit Dynamics > Solid Mechanics, Explicit Dynamics (solid)**.
- 3 Click **Add**.
- 4 Click  **Study**.
- 5 In the **Select Study** tree, select **Preset Studies for Selected Physics Interfaces > Explicit Dynamics**.
- 6 Click  **Done**.

GLOBAL DEFINITIONS

Parameters I

- 1 In the **Model Builder** window, under **Global Definitions** click **Parameters I**.
- 2 In the **Settings** window for **Parameters**, locate the **Parameters** section.
- 3 Click the **Load** button. From the menu, choose **Load from File**.
- 4 Browse to the model's Application Libraries folder and double-click the file `cable_crimping_parameters.txt`.

Triangle I (tri1)



Add a **Triangle** function that will be used to apply the prescribed displacement.

- 1 In the **Home** toolbar, click  **Functions** and choose **Global > Triangle**.
- 2 In the **Settings** window for **Triangle**, locate the **Parameters** section.
- 3 In the **Lower limit** text field, type 0.

- 4 In the **Upper limit** text field, type $2 \cdot t_{end}$.
- 5 In the **Amplitude** text field, type $disp$.
- 6 Click to expand the **Smoothing** section. Clear the **Size of transition zone** checkbox.

GEOMETRY I

Import the geometry sequence from an auxiliary file. Complete instructions to create the geometry are available in the [Geometry Instructions](#) section.

- 1 In the **Geometry** toolbar, click **Insert Sequence** and choose **Insert Sequence**.
- 2 Browse to the model's Application Libraries folder and double-click the file `cable_crimping_geom_sequence.mph`.
- 3 In the **Geometry** toolbar, click  **Build All**.
- 4 Click the  **Go to Default View** button in the **Graphics** toolbar.
- 5 In the **Model Builder** window, under **Component 1 (comp1)** click **Geometry 1**.

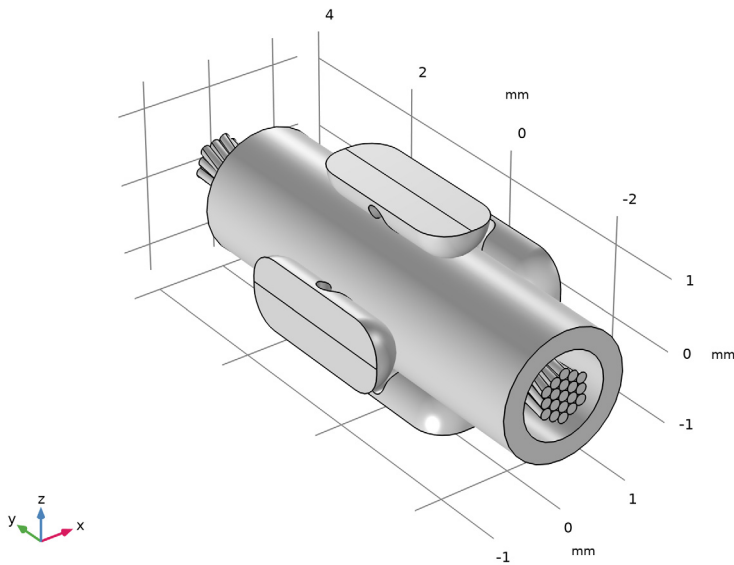

DEFINITIONS

Use a **General Contact Pair** to conveniently define multisurface contact interactions between all surfaces in the geometry.

General Contact Pair 1 (p1)

In the **Definitions** toolbar, click  **Pairs** and choose **General Contact Pair**.

SOLID MECHANICS, EXPLICIT DYNAMICS (SOLID)

- 1 In the **Model Builder** window, under **Component 1 (comp1)** click **Solid Mechanics, Explicit Dynamics (solid)**.
- 2 In the **Settings** window for **Solid Mechanics, Explicit Dynamics**, click to expand the **Energy Dissipation** section.
- 3 From the **Store dissipation** list, choose **Total**.

Linear Elastic Material 1

Tune the hourglass stabilization method to exclude inelastic effects, which can help alleviate problems during unloading.

- 1 In the **Model Builder** window, under **Component 1 (comp1)** > **Solid Mechanics, Explicit Dynamics (solid)** click **Linear Elastic Material 1**.
- 2 In the **Settings** window for **Linear Elastic Material**, locate the **Quadrature Settings** section.
- 3 Find the **Hexahedron** subsection. From the **Hourglass stabilization** list, choose **Flanagan–Belytschko**.
- 4 Find the **Advanced settings** subsection. From the **Inelastic deformations** list, choose **Ignore**.

Plasticity 1

- 1 In the **Physics** toolbar, click  **Attributes** and choose **Plasticity**.
- 2 In the **Settings** window for **Plasticity**, locate the **Domain Selection** section.
- 3 From the **Selection** list, choose **Deformable Domains** to model only the terminal and the wires as elastoplastic materials.
Keep the default settings to use a linear isotropic hardening model for both materials.

Contact Model 1

- 1 In the **Model Builder** window, expand the **General Contact 1** node, then click **Contact Model 1**.
- 2 In the **Settings** window for **Contact Model**, locate the **Contact Model** section.
- 3 From the **Penalty factor multiplier** list, choose **Manual tuning**.
- 4 In the f_p text field, type 0.5.

Friction 1

- 1 In the **Physics** toolbar, click  **Attributes** and choose **Friction**.

- 2 In the **Settings** window for **Friction**, locate the **Friction Parameters** section.
- 3 In the μ text field, type 0.2.

Fixed Constraint 1

- 1 In the **Physics** toolbar, click  **Boundaries** and choose **Fixed Constraint**.
- 2 Select Boundaries 6, 20, 23, 26, 46, 49, 52, 53, 71, 74, 79–81, 100, 103, 108, 109, and 124–126 only.

Prescribed Displacement 1

Prescribe the displacement of the four indenters.

- 1 In the **Physics** toolbar, click  **Domains** and choose **Prescribed Displacement**.
- 2 Select Domain 1 only.
- 3 In the **Settings** window for **Prescribed Displacement**, locate the **Prescribed Displacement** section.
- 4 Specify the u_0 vector as

$$\begin{array}{|c|c|} \hline \text{tri1}(t) & x \\ \hline \end{array}$$

Prescribed Displacement 2

- 1 In the **Physics** toolbar, click  **Domains** and choose **Prescribed Displacement**.
- 2 Select Domain 4 only.
- 3 In the **Settings** window for **Prescribed Displacement**, locate the **Prescribed Displacement** section.
- 4 Specify the u_0 vector as

$$\begin{array}{|c|c|} \hline -\text{tri1}(t) & z \\ \hline \end{array}$$

Prescribed Displacement 3

- 1 In the **Physics** toolbar, click  **Domains** and choose **Prescribed Displacement**.
- 2 Select Domain 24 only.
- 3 In the **Settings** window for **Prescribed Displacement**, locate the **Prescribed Displacement** section.
- 4 Specify the u_0 vector as

$$\begin{array}{|c|c|} \hline -\text{tri1}(t) & x \\ \hline \end{array}$$

Prescribed Displacement 4

- 1 In the **Physics** toolbar, click  **Domains** and choose **Prescribed Displacement**.

- 2 Select Domain 3 only.
- 3 In the **Settings** window for **Prescribed Displacement**, locate the **Prescribed Displacement** section.
- 4 Specify the u_0 vector as

$$\begin{matrix} \text{tri1}(t) & | & z \\ \hline \end{matrix}$$

MATERIALS

Add the required material properties for the wires, terminal, and indenters.

Wire

- 1 In the **Model Builder** window, under **Component 1 (comp1)** right-click **Materials** and choose **Blank Material**.
- 2 In the **Settings** window for **Material**, locate the **Geometric Entity Selection** section.
- 3 From the **Selection** list, choose **Wire Domains**.
- 4 In the **Label** text field, type Wire.
- 5 Locate the **Material Contents** section. In the table, enter the following settings:

Property	Variable	Value	Unit	Property group
Young's modulus	E	130 [GPa]	Pa	Young's modulus and Poisson's ratio
Poisson's ratio	nu	0.34	l	Young's modulus and Poisson's ratio
Density	rho	8.96 [g/cm ³]	kg/m ³	Basic
Initial yield stress	sigmags	90 [MPa]	Pa	Elastoplastic material model
Isotropic tangent modulus	Et	370 [MPa]	Pa	Elastoplastic material model

Terminal

- 1 Right-click **Materials** and choose **Blank Material**.
- 2 In the **Settings** window for **Material**, type Terminal in the **Label** text field.
- 3 Locate the **Geometric Entity Selection** section. From the **Selection** list, choose **Terminal Domains**.

4 Locate the **Material Contents** section. In the table, enter the following settings:

Property	Variable	Value	Unit	Property group
Young's modulus	E	135 [GPa]	Pa	Young's modulus and Poisson's ratio
Poisson's ratio	nu	0.35		Young's modulus and Poisson's ratio
Density	rho	8.3 [g/cm ³]	kg/m ³	Basic
Initial yield stress	sigmags	480 [MPa]	Pa	Elastoplastic material model
Isotropic tangent modulus	Et	285 [MPa]	Pa	Elastoplastic material model

Indenter

- 1 Right-click **Materials** and choose **Blank Material**.
- 2 In the **Settings** window for **Material**, type Indenter in the **Label** text field.
- 3 Locate the **Geometric Entity Selection** section. From the **Selection** list, choose **Indenter Domains**.
- 4 Locate the **Material Contents** section. In the table, enter the following settings:

Property	Variable	Value	Unit	Property group
Young's modulus	E	200 [GPa]	Pa	Young's modulus and Poisson's ratio
Poisson's ratio	nu	0.3		Young's modulus and Poisson's ratio
Density	rho	8 [g/cm ³]	kg/m ³	Basic



MESH 1

When using explicit time integration, care must be taken to create a mesh that avoids small, low-quality elements, which restrict the stable time step. For this reason, use **Swept** mesh operations to mesh the terminal and the wires with hexahedral elements. Constant strain tetrahedral elements should generally be avoided, but they can be used to mesh the indenters for which the displacement field is prescribed.

Free Quad 1

- 1 In the **Mesh** toolbar, click  **More Generators** and choose **Free Quad**.
- 2 Select Boundary 79 only.



Copy Face 1

- 1 In the **Mesh** toolbar, click  **Copy** and choose **Copy Face**.
- 2 Select Boundary 79 only.
- 3 In the **Settings** window for **Copy Face**, locate the **Destination Boundaries** section.
- 4 Click to select the  **Activate Selection** toggle button.
- 5 Select Boundaries 20, 23, 26, 46, 49, 52, 53, 71, 74, 80, 81, 100, 103, 108, 109, and 124–126 only.
- 6 In the list box, select **126**.

Size

- 1 In the **Model Builder** window, click **Size**.
- 2 In the **Settings** window for **Size**, locate the **Element Size** section.
- 3 Click the **Custom** button.
- 4 Locate the **Element Size Parameters** section. In the **Maximum element size** text field, type 0.075.
- 5 In the **Minimum element size** text field, type 0.05.

Swept 1

- 1 In the **Mesh** toolbar, click  **Swept**.
- 2 In the **Settings** window for **Swept**, locate the **Domain Selection** section.
- 3 From the **Geometric entity level** list, choose **Domain**.
- 4 From the **Selection** list, choose **Wire Domains**.
- 5 Click  **Build Selected**.

Mapped 1

- 1 In the **Mesh** toolbar, click  **More Generators** and choose **Mapped**.
- 2 Select Boundaries 6 and 138–140 only.

Distribution 1

- 1 Right-click **Mapped 1** and choose **Distribution**.
- 2 Select Edges 270, 273, 276, and 282 only.
- 3 In the **Settings** window for **Distribution**, locate the **Distribution** section.
- 4 In the **Number of elements** text field, type 4.

Swept 2

- 1 In the **Mesh** toolbar, click  **Swept**.

- 2 In the **Settings** window for **Swept**, locate the **Domain Selection** section.
- 3 From the **Geometric entity level** list, choose **Domain**.
- 4 From the **Selection** list, choose **Terminal Domains**.

Distribution I

- 1 Right-click **Swept 2** and choose **Distribution**.
Refine the mesh in the central portion of the terminal where contact is expected.
- 2 In the **Settings** window for **Distribution**, locate the **Distribution** section.
- 3 From the **Distribution type** list, choose **Explicit**.
- 4 In the **Relative placement of vertices along edge** text field, type range(0,0.1,1)
range(1.05,0.05,2) range(2.1,0.1,3).
- 5 Click  **Build Selected**.

Free Triangular I

For the indenters where the displacement field is prescribed, use a fine triangular mesh on the contact surfaces and a coarse mesh for the remaining domains.

- 1 In the **Mesh** toolbar, click  **More Generators** and choose **Free Triangular**.
- 2 Select Boundaries 2, 4, 10, 11, 14, 15, 131, and 132 only.

Size I

- 1 Right-click **Free Triangular I** and choose **Size**.
- 2 In the **Settings** window for **Size**, locate the **Element Size** section.
- 3 Click the **Custom** button.
- 4 Locate the **Element Size Parameters** section.
- 5 Select the **Maximum element size** checkbox. In the associated text field, type 0.05.

Free Tetrahedral I

In the **Mesh** toolbar, click  **Free Tetrahedral**.

Size I

- 1 Right-click **Free Tetrahedral I** and choose **Size**.
- 2 In the **Settings** window for **Size**, locate the **Element Size** section.
- 3 From the **Predefined** list, choose **Extremely coarse**.
- 4 Click  **Build All**.

STUDY I

Step 1: Explicit Dynamics



- 1 In the **Model Builder** window, under **Study I** click **Step 1: Explicit Dynamics**.
- 2 In the **Settings** window for **Explicit Dynamics**, locate the **Study Settings** section.
- 3 From the **Time unit** list, choose **µs**.
- 4 In the **Output times** text field, type range (0, 0.5, 10.5).

Before computing, create a plot of the central cross-section that can be used to monitor the solution while solving. Start by computing the initial values.



- 5 In the **Study** toolbar, click  **Get Initial Value**.

RESULTS

Cut Plane 1

- 1 In the **Results** toolbar, click  **Cut Plane**.
- 2 In the **Settings** window for **Cut Plane**, locate the **Plane Data** section.
- 3 From the **Plane** list, choose **XZ-planes**.
- 4 In the **Y-coordinate** text field, type $-H_i/4$.
- 5 Click  **Plot** to verify the placement and orientation of the cut plane.

Preferred Units 1

- 1 In the **Results** toolbar, click  **Configurations** and choose **Preferred Units**.
- 2 In the **Settings** window for **Preferred Units**, locate the **Units** section.
- 3 Click  **Add Physical Quantity**.
- 4 In the **Physical Quantity** dialog, type stress in the text field.
- 5 In the tree, select **Solid Mechanics > Stress tensor (N/m²)**.
- 6 Click **OK**.
- 7 In the **Settings** window for **Preferred Units**, locate the **Units** section.
- 8 In the table, enter the following settings:

Quantity	Unit	Preferred unit
Stress tensor	N/m ²	MPa

- 9 Click  **Apply**.

Stress, Cross Section

- 1 In the **Results** toolbar, click  **2D Plot Group**.

- 2 In the **Settings** window for **2D Plot Group**, type **Stress, Cross Section** in the **Label** text field.
- 3 Locate the **Plot Settings** section. From the **Frame** list, choose **Spatial (x, y, z)**.

Surface 1

- 1 Right-click **Stress, Cross Section** and choose **Surface**.
- 2 In the **Settings** window for **Surface**, locate the **Expression** section.
- 3 In the **Expression** text field, type `solid.misesGp`.
- 4 Locate the **Coloring and Style** section. From the **Color table** list, choose **Prism**.
- 5 Click to expand the **Quality** section. From the **Evaluation settings** list, choose **Manual**.
- 6 From the **Resolution** list, choose **No refinement**.

Deformation 1

- 1 Right-click **Surface 1** and choose **Deformation**.
- 2 In the **Settings** window for **Deformation**, locate the **Scale** section.
- 3 Select the **Scale factor** checkbox. In the associated text field, type `1`.
- 4 In the **Stress, Cross Section** toolbar, click  **Plot**.

STUDY 1

Step 1: Explicit Dynamics

- 1 In the **Model Builder** window, under **Study 1** click **Step 1: Explicit Dynamics**.
- 2 In the **Settings** window for **Explicit Dynamics**, click to expand the **Results While Solving** section.
- 3 Select the **Plot** checkbox.
- 4 In the table, enter the following settings:

Plot group	Plot window
Stress, Cross Section	Graphics

- 5 In the **Study** toolbar, click  **Compute**.

RESULTS

Stress (solid)

Start by visualizing the stress and the deformed shape of the crimp joint after unloading.

- 1 In the **Settings** window for **3D Plot Group**, locate the **Plot Settings** section.

2 Clear the **Plot dataset edges** checkbox.

3 Click  **Plot Last**.

Line 1

1 Right-click **Stress (solid)** and choose **Line**.

2 In the **Settings** window for **Line**, locate the **Expression** section.

3 In the **Expression** text field, type 1.

4 Click to expand the **Title** section. From the **Title type** list, choose **None**.

5 Locate the **Coloring and Style** section. From the **Coloring** list, choose **Uniform**.

6 From the **Color** list, choose **Black**.

7 Click to expand the **Inherit Style** section. From the **Plot** list, choose **Volume 1**.

8 Clear the **Color** checkbox.

9 Clear the **Color and data range** checkbox.

Deformation 1

Right-click **Line 1** and choose **Deformation**.

Selection 1

1 In the **Model Builder** window, right-click **Line 1** and choose **Selection**.

2 In the **Settings** window for **Selection**, locate the **Selection** section.

3 From the **Geometric entity level** list, choose **Domain**.

4 From the **Selection** list, choose **Deformable Domains**.

Selection 1

1 In the **Model Builder** window, right-click **Volume 1** and choose **Selection**.

2 In the **Settings** window for **Selection**, locate the **Selection** section.

3 From the **Selection** list, choose **Deformable Domains**.

Stress (solid)

1 In the **Model Builder** window, under **Results** click **Stress (solid)**.

2 In the **Stress (solid)** toolbar, click  **Plot**.

3 Click the  **Go to Default View** button in the **Graphics** toolbar.

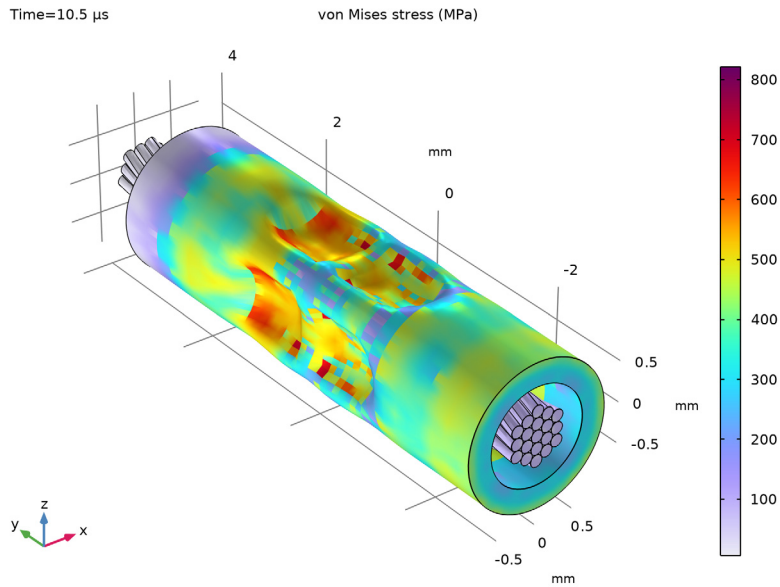

Multiselect Solution 1

Next, visualize the equivalent plastic strain in the crimp joint cross-section for a few select time points.

- 1 In the **Results** toolbar, click  **Configurations** and choose **Multiselect Solution**.
- 2 In the **Settings** window for **Multiselect Solution**, locate the **Solution** section.
- 3 From the **Time selection** list, choose **From list**.
- 4 In the **Times (μ s)** list, choose **6.5, 8.5, 10, and 10.5**.

Stress, Cross Section

In the **Model Builder** window, under **Results** click **Stress, Cross Section**.

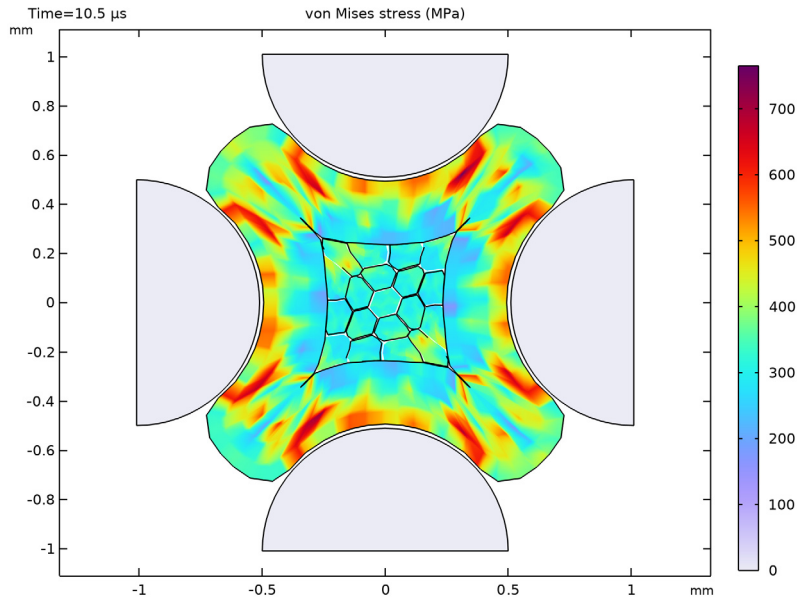

Equivalent Plastic Strain, Cross Section

- 1 Right-click **Stress, Cross Section** and choose **Duplicate**.
- 2 In the **Settings** window for **2D Plot Group**, type Equivalent Plastic Strain, Cross Section in the **Label** text field.
- 3 Click to expand the **Title** section. From the **Title type** list, choose **Custom**.
- 4 Find the **Solution** subsection. Clear the **Solution** checkbox.
- 5 Find the **Type and data** subsection. Clear the **Type** checkbox.
- 6 Locate the **Plot Settings** section. Clear the **Plot dataset edges** checkbox.
- 7 Click to collapse the **Title** section. Locate the **Plot Settings** section. From the **View** list, choose **New view**.
- 8 Click to expand the **Plot Array** section. From the **Array type** list, choose **Square**.

Surface 1

- 1 In the **Model Builder** window, expand the **Equivalent Plastic Strain, Cross Section** node, then click **Surface 1**.
- 2 In the **Settings** window for **Surface**, locate the **Expression** section.

- 3 In the **Expression** text field, type `solid.epeGp`.
- 4 Locate the **Coloring and Style** section. From the **Color table** list, choose **AuroraAustralisDark**.

Line 1

- 1 In the **Model Builder** window, right-click **Equivalent Plastic Strain, Cross Section** and choose **Line**.
- 2 In the **Settings** window for **Line**, locate the **Expression** section.
- 3 In the **Expression** text field, type 1.
- 4 Click to expand the **Title** section. From the **Title type** list, choose **None**.
- 5 Locate the **Coloring and Style** section. From the **Coloring** list, choose **Uniform**.
- 6 From the **Color** list, choose **Black**.
- 7 Click to expand the **Inherit Style** section. From the **Plot** list, choose **Surface 1**.
- 8 Clear the **Color** checkbox.
- 9 Clear the **Color and data range** checkbox.
- 10 Click to expand the **Plot Array** section. Select the **Manual indexing** checkbox.

Deformation 1

Right-click **Line 1** and choose **Deformation**.

Equivalent Plastic Strain, Cross Section

In the **Equivalent Plastic Strain, Cross Section** toolbar, click  **Plot**.

Annotation 1

- 1 In the **Model Builder** window, right-click **Equivalent Plastic Strain, Cross Section** and choose **Annotation**.
- 2 In the **Settings** window for **Annotation**, locate the **Annotation** section.
- 3 In the **Text** text field, type `t = eval(t,us,3) μs`.
- 4 From the **Geometry level** list, choose **Global**.
- 5 Locate the **Position** section. In the **y** text field, type `-1.5`.
- 6 Locate the **Coloring and Style** section. Clear the **Show point** checkbox.
- 7 From the **Anchor point** list, choose **Center**.
- 8 Click to expand the **Plot Array** section. Select the **Manual indexing** checkbox.

Solution Array 1

- 1 In the **Model Builder** window, right-click **Surface 1** and choose **Solution Array**.

- 2 In the **Settings** window for **Solution Array**, locate the **Data** section.
- 3 From the **Solution parameters** list, choose **From configuration**.
- 4 Locate the **Plot Array** section. From the **Array shape** list, choose **Square**.
- 5 Right-click **Solution Array 1** and choose **Copy**.



Solution Array 1

In the **Model Builder** window, right-click **Line 1** and choose **Paste Solution Array**.

Solution Array 1

In the **Model Builder** window, right-click **Annotation 1** and choose **Paste Solution Array**.

Equivalent Plastic Strain, Cross Section

- 1 In the **Equivalent Plastic Strain, Cross Section** toolbar, click  **Plot**.
- 2 Click the  **Zoom Extents** button in the **Graphics** toolbar.
- 3 Click the  **Show Grid** button in the **Graphics** toolbar.
- 4 In the **Model Builder** window, under **Results** click **Equivalent Plastic Strain, Cross Section**.

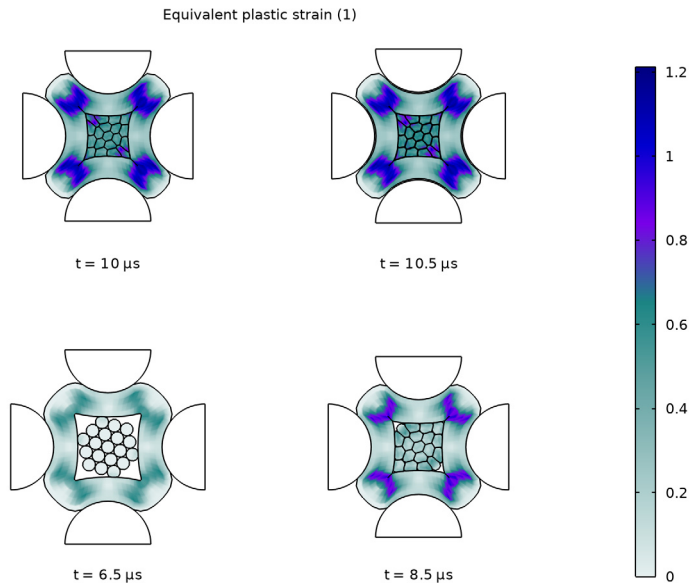

Indenter Reaction Force

Evaluate the reaction force applied to one of the indenters.

- 1 In the **Results** toolbar, click  **ID Plot Group**.

- 2 In the **Settings** window for **ID Plot Group**, type Indenter Reaction Force in the **Label** text field.
- 3 Locate the **Data** section. From the **Solution parameters** list, choose **From configuration**.
- 4 Click to expand the **Title** section. From the **Title type** list, choose **None**.
- 5 Locate the **Legend** section. Clear the **Show legends** checkbox.

Global 1

- 1 Right-click **Indenter Reaction Force** and choose **Global**.
- 2 In the **Settings** window for **Global**, locate the **Data** section.
- 3 From the **Dataset** list, choose **Study 1/Solution 1 (sol1)**.
- 4 Click **Add Expression** in the upper-right corner of the **y-Axis Data** section. From the menu, choose **Component 1 (comp1) > Solid Mechanics, Explicit Dynamics > Reactions > Prescribed Displacement 1 > Reaction force (spatial frame) - N > solid.pdisp1.RFsumx - Reaction force, x-component**.
- 5 Locate the **x-Axis Data** section. From the **Parameter** list, choose **Expression**.
- 6 In the **Expression** text field, type $\text{tr11}(t)$.
- 7 Select the **Description** checkbox. In the associated text field, type Indentation depth.
- 8 Click to expand the **Coloring and Style** section. From the **Width** list, choose **2**.

Duplicate the plot to mark the time points shown in the previous plot group of the equivalent plastic strain in the joint cross-section.

Global 2

- 1 Right-click **Global 1** and choose **Duplicate**.
- 2 In the **Settings** window for **Global**, locate the **Data** section.
- 3 From the **Dataset** list, choose **From parent**.
- 4 Locate the **Coloring and Style** section. Find the **Line style** subsection. From the **Line** list, choose **None**.
- 5 Find the **Line markers** subsection. From the **Marker** list, choose **Circle**.

6 In the **Indenter Reaction Force** toolbar, click  **Plot**.

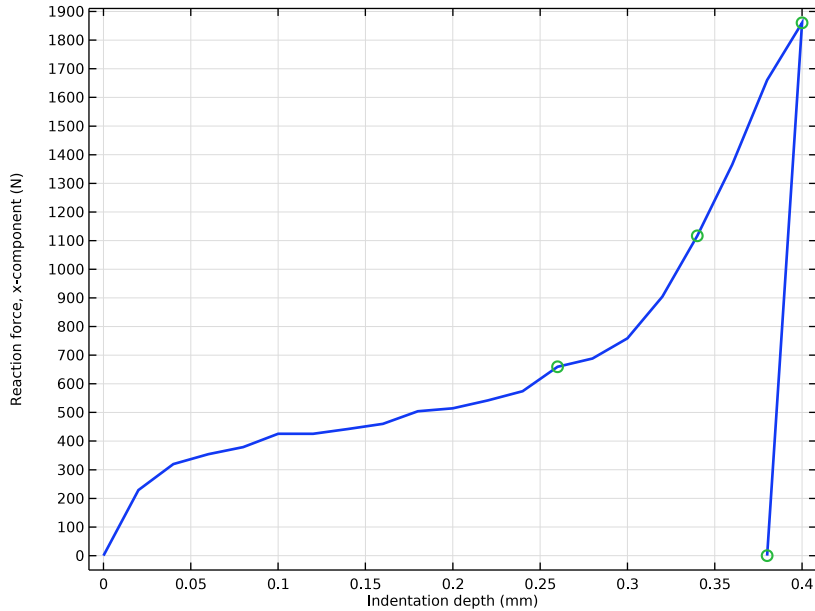

Energy Evaluation

For results verification, compute the amount of kinetic and hourglass stabilization energy in comparison to the elastic and dissipated energy in the material. In this particular example, the indentation speed has been set to an unphysically high value to obtain a reasonable total simulation time in comparison with the stable time step. We therefore need to verify that the inertial effects are reasonably small compared to the elastic and dissipated energy.

- 1 In the **Results** toolbar, click  **Evaluation Group**.
- 2 In the **Settings** window for **Evaluation Group**, type Energy Evaluation in the **Label** text field.

Global Evaluation 1

- 1 Right-click **Energy Evaluation** and choose **Global Evaluation**.
- 2 In the **Settings** window for **Global Evaluation**, locate the **Expressions** section.

3 In the table, enter the following settings:

Expression	Unit	Description
solid.Ws_tot	J	Total elastic strain energy
solid.Wd_tot	J	Total energy dissipation
solid.Wstb_tot	J	Total stabilization strain energy

Energy Evaluation

Exclude the indenter domains from the kinetic energy evaluation where the displacement is prescribed and the density is arbitrary.

Volume Integration 1

- 1 In the **Model Builder** window, right-click **Energy Evaluation** and choose **Integration > Volume Integration**.
- 2 In the **Settings** window for **Volume Integration**, locate the **Selection** section.
- 3 From the **Selection** list, choose **Deformable Domains**.
- 4 Locate the **Expressions** section. In the table, enter the following settings:

Expression	Unit	Description
solid.Wk	J	Kinetic energy

- 5 Locate the **Integration Settings** section.
- 6 Select the **Integration order** checkbox. In the associated text field, type 2.
- 7 In the **Energy Evaluation** toolbar, click  **Evaluate**.

ENERGY EVALUATION

- 1 Go to the **Energy Evaluation** window.
- 2 Click the **Table Graph** button in the window toolbar.

RESULTS

Table Graph 1

- 1 In the **Settings** window for **Table Graph**, locate the **Coloring and Style** section.
- 2 Find the **Line markers** subsection. From the **Marker** list, choose **Cycle**.
- 3 Click to expand the **Legends** section. Select the **Show legends** checkbox.

Energy Verification

- 1 In the **Model Builder** window, under **Results** click **ID Plot Group 5**.

- 2 In the **Settings** window for **ID Plot Group**, type **Energy Verification** in the **Label** text field.
- 3 Locate the **Plot Settings** section.
- 4 Select the **y-axis label** checkbox. In the associated text field, type **Energy (J)**.
- 5 Locate the **Legend** section. From the **Position** list, choose **Upper left**.
- 6 In the **Energy Verification** toolbar, click  **Plot**.

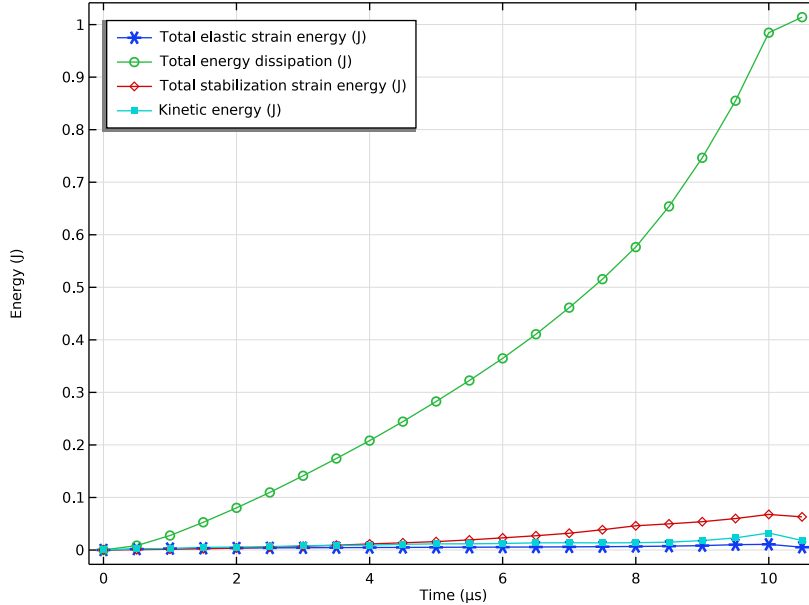



Geometry Instructions

From the **File** menu, choose **New**.

NEW

In the **New** window, click  **Model Wizard**.

MODEL WIZARD

- 1 In the **Model Wizard** window, click  **3D**.
- 2 Click  **Done**.

GLOBAL DEFINITIONS

Parameters 1

- 1 In the **Model Builder** window, under **Global Definitions** click **Parameters 1**.
- 2 In the **Settings** window for **Parameters**, locate the **Parameters** section.
- 3 Click the **Load** button. From the menu, choose **Load from File**.
- 4 Browse to the model's Application Libraries folder and double-click the file `cable_crimping_parameters.txt`.

GEOMETRY 1

Start by creating the wire strands. Draw the cross-section on a work plane, which can be swept with a helical twist angle.

- 1 In the **Model Builder** window, under **Component 1 (comp1)** click **Geometry 1**.
- 2 In the **Settings** window for **Geometry**, locate the **Units** section.
- 3 From the **Length unit** list, choose **mm**.

Work Plane 1 (wp1)

- 1 In the **Geometry** toolbar, click  **Work Plane**.
- 2 In the **Settings** window for **Work Plane**, locate the **Plane Definition** section.
- 3 From the **Plane** list, choose **zx-plane**.
- 4 In the **y-coordinate** text field, type $-Ht/2$.

Work Plane 1 (wp1) > Plane Geometry

In the **Model Builder** window, click **Plane Geometry**.

Work Plane 1 (wp1) > Circle 1 (c1)

- 1 In the **Work Plane** toolbar, click  **Circle**.
- 2 In the **Settings** window for **Circle**, locate the **Size and Shape** section.
- 3 In the **Radius** text field, type $ds/2$.

Work Plane 1 (wp1) > Circle 2 (c2)

- 1 Right-click **Component 1 (comp1) > Geometry 1 > Work Plane 1 (wp1) > Plane Geometry > Circle 1 (c1)** and choose **Duplicate**.
- 2 In the **Settings** window for **Circle**, locate the **Position** section.
- 3 In the **xw** text field, type $ds+\delta$.

Work Plane 1 (wp1) > Rotate 1 (rot1)

- 1 In the **Work Plane** toolbar, click  **Transforms** and choose **Rotate**.

- 2 Select the object **c2** only.
- 3 In the **Settings** window for **Rotate**, locate the **Rotation** section.
- 4 In the **Angle** text field, type range (0, 60, 300).

Work Plane 1 (wp1) > Copy 1 (copy1)

- 1 In the **Work Plane** toolbar, click  **Transforms** and choose **Copy**.
- 2 Select the objects **rot1(1)** and **rot1(6)** only.
- 3 In the **Settings** window for **Copy**, locate the **Displacement** section.
- 4 In the **xw** text field, type $ds+deltas$.

Work Plane 1 (wp1) > Rotate 2 (rot2)

- 1 In the **Work Plane** toolbar, click  **Transforms** and choose **Rotate**.
- 2 Select the objects **copy1(1)** and **copy1(2)** only.
- 3 In the **Settings** window for **Rotate**, locate the **Rotation** section.
- 4 In the **Angle** text field, type range (0, 60, 300).

Line Segment 1 (ls1)

Create a construction line for the sweep operation.

- 1 In the **Model Builder** window, right-click **Geometry 1** and choose **More Primitives > Line Segment**.
- 2 In the **Settings** window for **Line Segment**, locate the **Starting Point** section.
- 3 From the **Specify** list, choose **Coordinates**.
- 4 In the **y** text field, type $-Ht/2$.
- 5 Locate the **Endpoint** section. From the **Specify** list, choose **Coordinates**.
- 6 In the **y** text field, type $Ht/2+1$ [mm].
- 7 Locate the **Assigned Attributes** section. Select the **Construction geometry** checkbox.

Sweep 1 (swel)

- 1 In the **Geometry** toolbar, click  **Sweep**.
- 2 On the object **wp1**, select Boundaries 1–19 only.
- 3 In the **Settings** window for **Sweep**, locate the **Spine Curve** section.
- 4 Click to select the **Activate Selection** toggle button for **Edges to follow**.
- 5 On the object **ls1**, select Edge 1 only.
- 6 Locate the **Motion of Cross Section** section. Find the **Additional twisting and scaling** subsection. In the **Twist angle** text field, type $\theta*s$.

7 Click  **Build Selected**.

Next, create the cylindrical terminal sleeve.

Cylinder 1 (cyl1)

- 1 In the **Geometry** toolbar, click  **Cylinder**.
- 2 In the **Settings** window for **Cylinder**, locate the **Size and Shape** section.
- 3 In the **Radius** text field, type $r2$.
- 4 In the **Height** text field, type Ht .
- 5 Locate the **Position** section. In the **y** text field, type $-Ht/2$.
- 6 Locate the **Axis** section. From the **Axis type** list, choose **y-axis**.
- 7 Click to expand the **Layers** section. In the table, enter the following settings:

Layer name	Thickness (mm)
Layer 1	$r2 - r1$

Delete Entities 1 (del1)

- 1 Right-click **Geometry 1** and choose **Delete Entities**.
- 2 In the **Settings** window for **Delete Entities**, locate the **Entities or Objects to Delete** section.
- 3 From the **Geometric entity level** list, choose **Domain**.
- 4 On the object **cyll**, select Domain 3 only.

Work Plane 2 (wp2)

Finally, build the indenter geometry. Start by drawing the exterior geometry of the tool on a work plane.

- 1 In the **Geometry** toolbar, click  **Work Plane**.
Shift the origin of the work-plane coordinate system to simplify the drawing of the indenter. Include a small offset between the indenter and the cylinder.
- 2 In the **Settings** window for **Work Plane**, click to expand the **Local Coordinate System** section.
- 3 In the **xw-displacement** text field, type $-r2 - r6 - 1 [um]$.

Work Plane 2 (wp2) > Plane Geometry

In the **Model Builder** window, click **Plane Geometry**.

Work Plane 2 (wp2) > Polygon 1 (pol1)

- 1 In the **Work Plane** toolbar, click  **Polygon**.

- 2 In the **Settings** window for **Polygon**, locate the **Object Type** section.
- 3 From the **Type** list, choose **Open curve**.
- 4 Locate the **Coordinates** section. In the table, enter the following settings:

xw (mm)	yw (mm)
0	0
0	Hi/2
r6-r5	Hi/2

Work Plane 2 (wp2) > Circular Arc 1 (ca1)

- 1 In the **Work Plane** toolbar, click  **More Primitives** and choose **Circular Arc**.
- 2 In the **Settings** window for **Circular Arc**, locate the **Properties** section.
- 3 From the **Specify** list, choose **Endpoints and radius**.
- 4 Locate the **Starting Point** section. In the **xw** text field, type r6-r5.
- 5 In the **yw** text field, type Hi/2.
- 6 Locate the **Endpoint** section. In the **xw** text field, type r6.
- 7 In the **yw** text field, type r3+r4+d.
- 8 Locate the **Radius** section. In the **Radius** text field, type r5.
- 9 Locate the **Angles** section. Select the **Clockwise** checkbox.

Work Plane 2 (wp2) > Polygon 2 (pol2)

- 1 In the **Work Plane** toolbar, click  **Polygon**.
- 2 In the **Settings** window for **Polygon**, locate the **Object Type** section.
- 3 From the **Type** list, choose **Open curve**.
- 4 Locate the **Coordinates** section. In the table, enter the following settings:

xw (mm)	yw (mm)
r6	Hi/2-r5
r6	0

Work Plane 2 (wp2) > Mirror 1 (mir1)

- 1 In the **Work Plane** toolbar, click  **Transforms** and choose **Mirror**.
- 2 Click in the **Graphics** window and then press Ctrl+A to select all objects.
- 3 In the **Settings** window for **Mirror**, locate the **Input** section.
- 4 Select the **Keep input objects** checkbox.
- 5 Locate the **Normal Vector to Line of Reflection** section. In the **xw** text field, type 0.

6 In the **yw** text field, type 1.

Work Plane 2 (wp2) > Convert to Solid 1 (csol1)

- 1 In the **Work Plane** toolbar, click  **Conversions** and choose **Convert to Solid**.
- 2 Click in the **Graphics** window and then press Ctrl+A to select all objects.

Revolve 1 (rev1)

Revolve the work-plane geometry 180 degrees to create the base geometry of the indenter.

- 1 In the **Model Builder** window, right-click **Geometry 1** and choose **Revolve**.
- 2 In the **Settings** window for **Revolve**, locate the **Revolution Angles** section.
- 3 Click the **Angles** button.
- 4 In the **Start angle** text field, type -90.
- 5 In the **End angle** text field, type 90.

Work Plane 3 (wp3)

Add a new work plane to draw the cross section of the central cutout that is to be removed from the indenter.

- 1 In the **Geometry** toolbar, click  **Work Plane**.
- 2 In the **Settings** window for **Work Plane**, locate the **Local Coordinate System** section.
- 3 In the **xw-displacement** text field, type -r2-r6-1[um].

Work Plane 3 (wp3) > Plane Geometry

In the **Model Builder** window, click **Plane Geometry**.

Work Plane 3 (wp3) > Circular Arc 1 (ca1)

- 1 In the **Work Plane** toolbar, click  **More Primitives** and choose **Circular Arc**.
- 2 In the **Settings** window for **Circular Arc**, locate the **Center** section.
- 3 In the **xw** text field, type r6-r4.
- 4 Locate the **Radius** section. In the **Radius** text field, type r3.
- 5 Locate the **Angles** section. In the **Start angle** text field, type 90.
- 6 In the **End angle** text field, type 180.

Work Plane 3 (wp3) > Circular Arc 2 (ca2)

- 1 Right-click **Component 1 (comp1) > Geometry 1 > Work Plane 3 (wp3) > Plane Geometry > Circular Arc 1 (ca1)** and choose **Duplicate**.
- 2 In the **Settings** window for **Circular Arc**, locate the **Center** section.

- 3 In the **yw** text field, type $r3+r4$.
- 4 Locate the **Radius** section. In the **Radius** text field, type $r4$.
- 5 Locate the **Angles** section. In the **Start angle** text field, type -90 .
- 6 In the **End angle** text field, type 0 .

Work Plane 3 (wp3) > Polygon 1 (pol1)

- 1 In the **Work Plane** toolbar, click  **Polygon**.
- 2 In the **Settings** window for **Polygon**, locate the **Object Type** section.
- 3 From the **Type** list, choose **Open curve**.
- 4 Locate the **Coordinates** section. In the table, enter the following settings:

xw (mm)	yw (mm)
$r6$	$r3+r4$
$r6+d$	$r3+r4$
$r6+d$	0

Work Plane 3 (wp3) > Mirror 1 (mir1)

- 1 In the **Work Plane** toolbar, click  **Transforms** and choose **Mirror**.
- 2 Click in the **Graphics** window and then press **Ctrl+A** to select all objects.
- 3 In the **Settings** window for **Mirror**, locate the **Input** section.
- 4 Select the **Keep input objects** checkbox.
- 5 Locate the **Normal Vector to Line of Reflection** section. In the **xw** text field, type 0 .
- 6 In the **yw** text field, type 1 .

Work Plane 3 (wp3) > Convert to Solid 1 (csol1)



- 1 In the **Work Plane** toolbar, click  **Conversions** and choose **Convert to Solid**.
- 2 Click in the **Graphics** window and then press **Ctrl+A** to select all objects.

Extrude 1 (ext1)

- 1 In the **Model Builder** window, right-click **Geometry 1** and choose **Extrude**.
- 2 In the **Settings** window for **Extrude**, locate the **Distances** section.
- 3 In the table, enter the following settings:

Distances (mm)
$-2*r6$
$2*r6$

Difference 1 (dif1)

- 1 In the **Geometry** toolbar, click  **Booleans and Partitions** and choose **Difference**.
- 2 Select the object **rev1** only.
- 3 In the **Settings** window for **Difference**, locate the **Difference** section.
- 4 Click to select the  **Activate Selection** toggle button for **Objects to subtract**.
- 5 Select the object **ext1** only.
- 6 Click  **Build Selected**.

Explicit Selection 1 (sel1)

The indenter geometry is now complete and we can place multiple such objects around the cylinder by using a **Rotate** operation. First, create two selections for the curved surfaces, which will be used to remove some unnecessary edges in the finalized geometry.

- 1 In the **Geometry** toolbar, click  **Selections** and choose **Explicit Selection**.
- 2 In the **Settings** window for **Explicit Selection**, locate the **Entities to Select** section.
- 3 From the **Geometric entity level** list, choose **Boundary**.
- 4 On the object **dif1**, select Boundary 3 only.
- 5 Select the **Group by continuous tangent** checkbox.

Explicit Selection 2 (sel2)

- 1 In the **Geometry** toolbar, click  **Selections** and choose **Explicit Selection**.
- 2 In the **Settings** window for **Explicit Selection**, locate the **Entities to Select** section.
- 3 From the **Geometric entity level** list, choose **Boundary**.
- 4 On the object **dif1**, select Boundary 17 only.
- 5 Select the **Group by continuous tangent** checkbox.

Rotate 1 (rot1)

- 1 In the **Geometry** toolbar, click  **Transforms** and choose **Rotate**.
- 2 Select the object **dif1** only.
- 3 In the **Settings** window for **Rotate**, locate the **Rotation** section.
- 4 From the **Axis type** list, choose **y-axis**.
- 5 In the **Angle** text field, type range (0, 90, 270).

Form Union (fin)

- 1 In the **Model Builder** window, under **Component 1 (comp1) > Geometry 1** click **Form Union (fin)**.
- 2 In the **Settings** window for **Form Union/Assembly**, locate the **Form Union/Assembly** section.

- 3 From the **Action** list, choose **Form an assembly**.
- 4 Clear the **Create pairs** checkbox.
- 5 In the **Geometry** toolbar, click  **Build All**.



Mesh Control Domains 1 (mcd1)

- 1 In the **Geometry** toolbar, click  **Virtual Operations** and choose **Mesh Control Domains**.
- 2 On the object **fin**, select Domains 2–5 only.

Form Composite Faces 1 (cmf1)

- 1 In the **Geometry** toolbar, click  **Virtual Operations** and choose **Form Composite Faces**.
- 2 In the **Settings** window for **Form Composite Faces**, locate the **Input** section.
- 3 From the **Faces to composite** list, choose **Explicit Selection 1**.

Form Composite Faces 2 (cmf2)

- 1 Right-click **Form Composite Faces 1 (cmf1)** and choose **Duplicate**.
- 2 In the **Settings** window for **Form Composite Faces**, locate the **Input** section.
- 3 Click to select the  **Activate Selection** toggle button for **Faces to composite**.
- 4 From the **Faces to composite** list, choose **Explicit Selection 2**.
- 5 In the **Geometry** toolbar, click  **Build All**.

Wire Domains

- 1 In the **Geometry** toolbar, click  **Selections** and choose **Explicit Selection**.
- 2 In the **Settings** window for **Explicit Selection**, type Wire Domains in the **Label** text field.
- 3 On the object **cmf2**, select Domains 5–23 only.



Terminal Domains

- 1 In the **Geometry** toolbar, click  **Selections** and choose **Explicit Selection**.
- 2 In the **Settings** window for **Explicit Selection**, type Terminal Domains in the **Label** text field.
- 3 On the object **cmf2**, select Domain 2 only.

Indenter Domains

- 1 In the **Geometry** toolbar, click  **Selections** and choose **Explicit Selection**.
- 2 In the **Settings** window for **Explicit Selection**, type Indenter Domains in the **Label** text field.
- 3 On the object **cmf2**, select Domains 1, 3, 4, and 24 only.

Deformable Domains

- 1 In the **Geometry** toolbar, click  **Selections** and choose **Union Selection**.
- 2 In the **Settings** window for **Union Selection**, type Deformable Domains in the **Label** text field.
- 3 Locate the **Input Entities** section. Click  **Add**.
- 4 In the **Add** dialog, in the **Selections to add** list, choose **Wire Domains** and **Terminal Domains**.
- 5 Click **OK**.
- 6 In the **Geometry** toolbar, click  **Build All**.