



Model created in COMSOL Multiphysics 6.4

Buckling of HDPE Liners

Introduction

High Density Polyethylene (HDPE) is a thermoplastic material used in the oil and gas industry to make liners for damaged pipes, mainly due to its availability, low production costs, and ease of installation. These components have been reported to experience sudden collapse during idle times connected to maintenance, when the pressure inside the pipe drops. This type of failure is mainly caused by permeation of oil-derived gases between the liners and the inner pipe wall; the larger the volume of gas trapped in such a gap, the higher the pressure on the external surface of the liner, which will then lead to buckling when not balanced by pressure on the inner surface (Ref. 1).

The Bergstrom–Bischoff viscoplastic model has been shown to be suitable to predict the behavior of thermoplastic materials and can be used to foresee the collapse of HDPE liners under different working temperatures and loading strain rates.

Model Definition

This model uses a plane-strain approximation to simulate a 1 m long HDPE liner. The geometry of the cross section is depicted in [Figure 1](#). The thickness of the liner is 6.2 mm and the nominal outer diameter is 114 mm. A small geometrical defect is introduced in order to facilitate convergence to a single-lobe buckling collapse, which is the one mostly reported experimentally. In particular, one diameter is made 0.2% shorter. Considering such a defected geometry, the problem shows one mirror symmetry along the short diameter. As a consequence, the computational cost can be reduced by modeling only half of the cross section and using symmetry boundary conditions. The pipe is modeled as an infinitely rigid body.

T

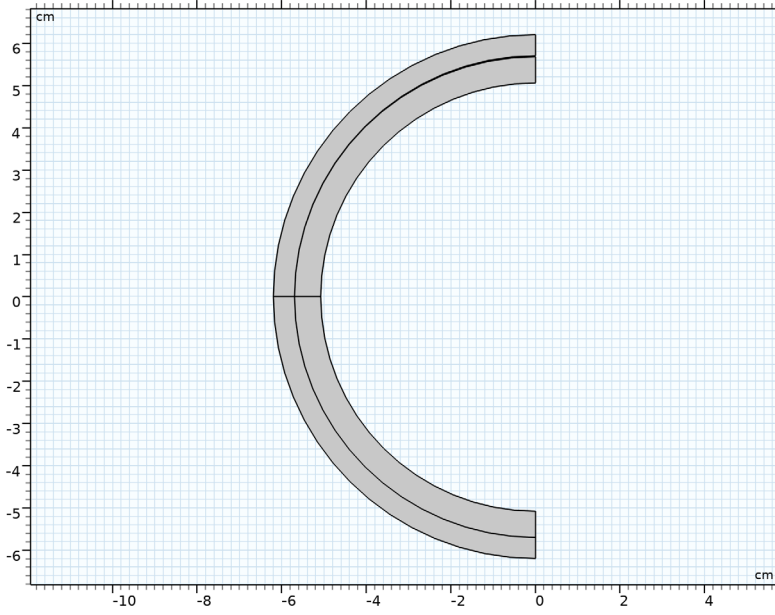

Figure 1: Model geometry.

MATERIAL MODEL

The inner surface of the liner is subjected to atmospheric pressure, simulating depressurization during shutdowns. The interaction between the gas in the annulus gap between the host pipe and the liner is instead simplified by the use of the ideal gas law, that is, the pressure acting on the outside of the liner is computed as

$$p = \frac{m_{\text{tot}} \left(\frac{R}{M} \right) T}{V}$$

Here, T is the absolute working temperature, R is the gas constant, and M is the molar mass of the considered gas. The pressure loading the liner is increased by imposing a constant inflow mass rate:

$$m_{\text{tot}} = \dot{m}t$$

Moreover, V is the current volume of the gap between the pipe and the liner, computed by accounting for the deformation of the liner.

The rheology of the Bergstrom–Bischoff material model is shown in [Figure 2](#). It features a so-called equilibrium network that can be schematized as a simple hyperelastic spring characterized by an Arruda–Boyce strain energy, with a temperature-dependent shear modulus:

$$\mu = \mu_0 \left(1 + \frac{T - \theta_0}{\theta_r} \right)$$

where θ_0 and θ_r are material properties. Such an equilibrium network is placed in parallel with two other networks that model the nonequilibrium behavior. Each of the latter networks are defined by an isochoric Arruda–Boyce spring in series with a viscoplastic element whose rate multiplier is given by

$$\lambda_i = A \left(\frac{\sigma_{vm}}{\sigma_{res,i} + a_i \max(p, 0)} \right)^{n_i} \left(\frac{T}{\theta_0} \right)^m \quad (1)$$

where σ_{vm} is the von Mises stress of the nonequilibrium network and A , a_i , n_i , m , and $\sigma_{res,i}$ identify material properties. The shear modulus of the nonequilibrium networks is controlled with an energy factor β_{vi} that sets the relative stiffness of each nonequilibrium network with respect to the equilibrium one. The energy factor of the second nonequilibrium network is made dependent on the viscoplastic strain of the first one by the differential equation

$$\dot{\beta}_{v2} = (-\alpha)(\beta_{v2} - \beta_{v,f})\lambda_1$$

where α and $\beta_{v,f}$ are material properties.

The numerical values of the material properties used in the model are given in [Table 1](#), and are inspired by those found in [Ref. 2](#).

TABLE 1: MATERIAL PROPERTIES.

Constant	Value	Description
μ_0	9.25 MPa	Shear modulus
Nseg	4.5	Number of segments
ρ	950 kg/m ³	Density
K	2 GPa	Bulk modulus
β_{v1}	20	Energy factor, network I
$\sigma_{res,1}$	7.1 MPa	Flow resistance, network I
a	0.183	Pressure coefficient
n_1	13	Stress exponent, network I

TABLE 1: MATERIAL PROPERTIES.

Constant	Value	Description
$\beta_{v,i}$	23.7	Initial energy factor, network 2
$\beta_{v,f}$	11.2	Final energy factor, network 2
$\sigma_{res,2}$	32.2 MPa	Flow resistance, network 2
n_2	22.4	Stress exponent
α	30	Energy factor evolution coefficient
θ_r	-94 K	Stiffness temperature response
m	117.2	Temperature exponent
θ_0	273.15 K	Reference temperature

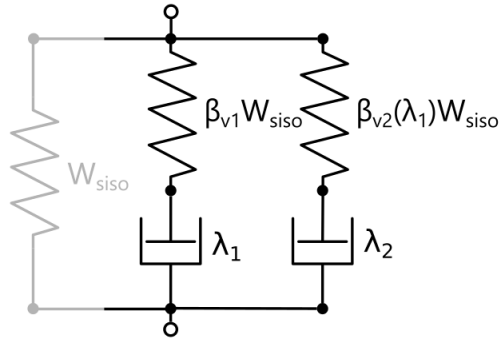

Figure 2: Rheology of the Bergstrom–Bischoff material model.

Results and Discussion

Figure 3 depicts the deformed shape of the liner after buckling at 278.15 K, showing the one-lobe type of collapse. The evolution of the gas pressure in the gap as a function of time is depicted in Figure 4, where it can be observed how the pressure suddenly drops after collapse as a consequence of the increased gap volume. The figure also shows how the collapse pressure reduces at high working temperatures.

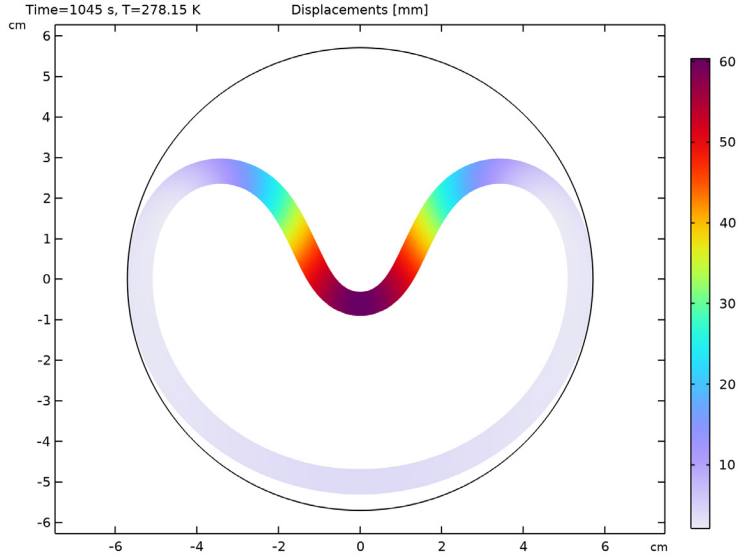

Figure 3: One-lobe failure of the HDPE liner.

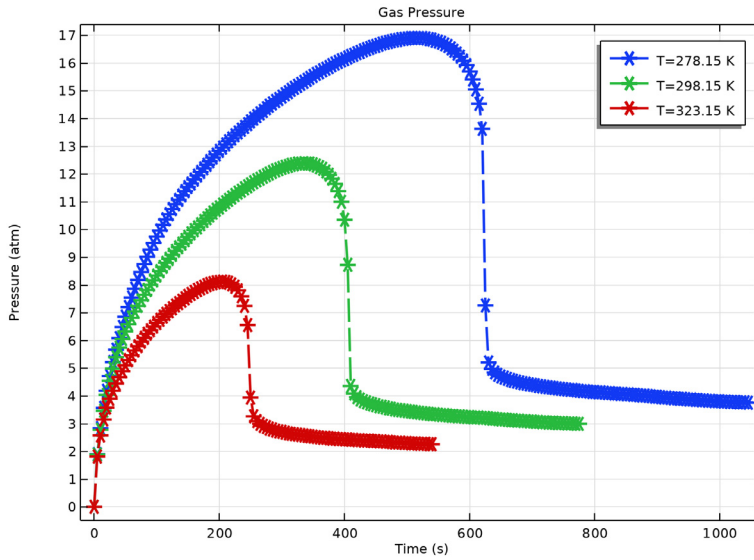

Figure 4: Evolution of pressure of the gas trapped in the gap between liner and pipe.

Notes About the COMSOL Implementation

- You can use the Bergstrom–Bischoff material model by adding a **Polymer Viscoplasticity** node under **Hyperelastic Material**. Select **Power Law** in the **Thermal Effects** section to add the temperature dependency to the rate multiplier. You find the **Domain ODEs** option in the **Time stepping** section under the **Polymer Viscoplasticity** node. This option can be faster than **Backward Euler** when the number of degrees of freedom is small.
- Add **Enclosed Cavity** nodes to compute the volume inside the liner, as well as the volume formed in between the pipe and liner. The pipe boundaries forming the pipe–liner cavity are not included in the **Solid Mechanics** interface, but these external boundaries can still be included in **Enclosed Cavity**.
- Note that because of the intrinsic time-dependent nature of the Bergstrom–Bischoff model, the buckling analysis must be conducted in the time domain, retaining the inertial terms. In such a way, when the stiffness of the system becomes singular, the whole strain energy can be converted into kinetic energy.
- The gas is assumed to permeate along the whole circumference of the liner in a uniform manner. For this reason, the pressure would be applied on the whole external surface of the liner, even if the initial nominal geometry assumes no gap between liner and pipe. To do that, select the **All regions** option instead of the default **Fallback and nonpair regions** under the **Applicable Pair Region** section in the **Free** boundary condition. This section is visible when you select **Advanced Physics Options** in the **Show More Options** menu.
- Add a **Stationary** study step before the **Time Dependent** one in order to compute consistent initial conditions, making contact easier to initiate at the first time steps. Use the **Instantaneous** stiffness of the Bergstrom–Bischoff material in the **Stationary** step.

References

1. F. Rueda, J.P. Torres, M. Machado, P.M. Frontini, and J.L. Otegui, “External pressure induced buckling collapse of high density polyethylene (HDPE) liners: FEM modeling and predictions,” *Thin-Walled Struct.*, vol. 96, pp. 56–63, 2015.
2. F. Rueda, A. Marquez, J.L. Otegui, and P.M. Frontini, “Buckling collapse of HDPE liners: Experimental set-up and FEM simulations,” *Thin-Walled Struct.*, vol. 109, pp. 103–112, 2016.

Application Library path: Nonlinear_Structural_Materials_Module/
Viscoplasticity/buckling_hdpe_liner



Modeling Instructions

From the **File** menu, choose **New**.

NEW

In the **New** window, click  **Model Wizard**.

MODEL WIZARD

- 1 In the **Model Wizard** window, click  **2D**.
- 2 In the **Select Physics** tree, select **Structural Mechanics > Solid Mechanics (solid)**.
- 3 Click **Add**.
- 4 Click  **Study**.
- 5 In the **Select Study** tree, select **General Studies > Time Dependent**.
- 6 Click  **Done**.

GLOBAL DEFINITIONS

Material Properties

- 1 In the **Model Builder** window, under **Global Definitions** click **Parameters 1**.
- 2 In the **Settings** window for **Parameters**, type Material Properties in the **Label** text field.
- 3 Locate the **Parameters** section. In the table, enter the following settings:

Name	Expression	Value	Description
mu	9.25[MPa]	9.25E6 Pa	Shear modulus
beta1	20	20	Energy factor, network 1
beta2_i	23.7	23.7	Initial energy factor, network 2
beta2_f	11.2	11.2	Final energy factor, network 2
alpha	30	30	Energy factor evolution coefficient
thetar	-94[K]	-94 K	Stiffness temperature response

Name	Expression	Value	Description
m	117.2	117.2	Temperature exponent
theta0	273.15[K]	273.15 K	Reference temperature
T	293.15[K]	293.15 K	Temperature

Geometrical Parameters

- 1 In the **Home** toolbar, click  **Parameters** and choose **Add > Parameters**.
- 2 In the **Settings** window for **Parameters**, type Geometrical Parameters in the **Label** text field.
- 3 Locate the **Parameters** section. In the table, enter the following settings:

Name	Expression	Value	Description
L	1[m]	1 m	Length of pipe
outer_r	114[mm]/2	0.057 m	Outer radius of liner
th_liner	6.2[mm]	0.0062 m	Thickness of liner
th_pipe	5[mm]	0.005 m	Thickness of pipe

Gas Properties

- 1 In the **Home** toolbar, click  **Parameters** and choose **Add > Parameters**.
- 2 In the **Settings** window for **Parameters**, type Gas Properties in the **Label** text field.
- 3 Locate the **Parameters** section. In the table, enter the following settings:

Name	Expression	Value	Description
M	16.04[g/mol]	0.01604 kg/mol	Molar mass
Rs	R_const/M	518.36 J/(kg·K)	Gas constant per unit mass
mdot	750[cm ³ /min]* 0.657[kg/m ³]	8.2125E-6 kg/s	Mass flow rate

GEOMETRY I

- 1 In the **Model Builder** window, under **Component 1 (comp1)** click **Geometry 1**.
- 2 In the **Settings** window for **Geometry**, locate the **Units** section.
- 3 From the **Length unit** list, choose **cm**.

Circle 1 (c1)

- 1 In the **Geometry** toolbar, click  **Circle**.
- 2 In the **Settings** window for **Circle**, locate the **Size and Shape** section.

- 3 In the **Radius** text field, type `outer_r`.
- 4 In the **Sector angle** text field, type 180.
- 5 Locate the **Rotation Angle** section. In the **Rotation** text field, type 180.
- 6 Click to expand the **Layers** section. In the table, enter the following settings:

Layer name	Thickness (cm)
Layer 1	<code>th_liner</code>

- 7 Click  **Build Selected**.

Ellipse 1 (e1)

- 1 In the **Geometry** toolbar, click  **Ellipse**.
- 2 In the **Settings** window for **Ellipse**, locate the **Size and Shape** section.
- 3 In the **a-semiaxis** text field, type `outer_r`.
- 4 In the **b-semiaxis** text field, type `outer_r*0.996`.
- 5 In the **Sector angle** text field, type 180.
- 6 Click to expand the **Layers** section. In the table, enter the following settings:

Layer name	Thickness (cm)
Layer 1	<code>th_liner</code>

- 7 Click  **Build Selected**.

Delete Entities 1 (del1)

- 1 In the **Model Builder** window, right-click **Geometry 1** and choose **Delete Entities**.
- 2 In the **Settings** window for **Delete Entities**, locate the **Entities or Objects to Delete** section.
- 3 From the **Geometric entity level** list, choose **Domain**.
- 4 On the object **e1**, select Domains 1 and 2 only.
- 5 On the object **e1**, select Domains 2 and 3 only.

Circle 2 (c2)



- 1 In the **Geometry** toolbar, click  **Circle**.
- 2 In the **Settings** window for **Circle**, locate the **Size and Shape** section.
- 3 In the **Radius** text field, type `outer_r+th_pipe`.
- 4 In the **Sector angle** text field, type 180.
- 5 Locate the **Rotation Angle** section. In the **Rotation** text field, type 90.

6 Click to expand the **Layers** section. In the table, enter the following settings:



Layer name	Thickness (cm)
Layer 1	th_pipe

7 Click  **Build Selected**.

Delete Entities 2 (del2)

- 1 Right-click **Geometry 1** and choose **Delete Entities**.
- 2 In the **Settings** window for **Delete Entities**, locate the **Entities or Objects to Delete** section.
- 3 From the **Geometric entity level** list, choose **Domain**.
- 4 On the object **c2**, select Domain 2 only.
- 5 Click  **Build Selected**.
- 6 Click the  **Zoom Extents** button in the **Graphics** toolbar.

Union 1 (un1)



- 1 In the **Geometry** toolbar, click  **Booleans and Partitions** and choose **Union**.
- 2 Select the objects **del1(1)** and **del1(2)** only.
- 3 In the **Settings** window for **Union**, click  **Build Selected**.



Form Union (fin)

- 1 In the **Model Builder** window, under **Component 1 (comp1) > Geometry 1** click **Form Union (fin)**.
- 2 In the **Settings** window for **Form Union/Assembly**, locate the **Form Union/Assembly** section.
- 3 From the **Action** list, choose **Form an assembly**.
- 4 Clear the **Create pairs** checkbox.
- 5 In the **Geometry** toolbar, click  **Build All**.

DEFINITIONS

Contact Pair 1 (p1)



- 1 In the **Definitions** toolbar, click  **Pairs** and choose **Contact Pair**.
- 2 Select Boundaries 6 and 7 only.
- 3 In the **Settings** window for **Pair**, locate the **Source Boundaries** section.
- 4 Click  **Create Selection**.

- 5 In the **Create Selection** dialog, type Pipe Inner Surface in the **Selection name** text field.
- 6 Click **OK**.
- 7 In the **Settings** window for **Pair**, locate the **Destination Boundaries** section.
- 8 Click to select the  **Activate Selection** toggle button.
- 9 Select Boundaries 11 and 12 only.
- 10 Click  **Create Selection**.
- 11 In the **Create Selection** dialog, type Liner Outer Surface in the **Selection name** text field.
- 12 Click **OK**.

Liner Inner Surface

- 1 In the **Definitions** toolbar, click  **Explicit**.
- 2 In the **Settings** window for **Explicit**, locate the **Input Entities** section.
- 3 From the **Geometric entity level** list, choose **Boundary**.
- 4 Select Boundaries 13 and 14 only.
- 5 In the **Label** text field, type Liner Inner Surface.

Pipe-Liner Cavity

- 1 In the **Definitions** toolbar, click  **Union**.
- 2 In the **Settings** window for **Union**, locate the **Geometric Entity Level** section.
- 3 From the **Level** list, choose **Boundary**.
- 4 Locate the **Input Entities** section. Under **Selections to add**, click  **Add**.
- 5 In the **Add** dialog, in the **Selections to add** list, choose **Pipe Inner Surface** and **Liner Outer Surface**.
- 6 Click **OK**.
- 7 In the **Settings** window for **Union**, type Pipe-Liner Cavity in the **Label** text field.

You can include only the liner in **Solid Mechanics**, since the pipe is modeled as a rigid boundary.

SOLID MECHANICS (SOLID)

- 1 In the **Model Builder** window, under **Component 1 (comp1)** click **Solid Mechanics (solid)**.
- 2 Select Domains 3 and 4 only.
- 3 In the **Settings** window for **Solid Mechanics**, locate the **Domain Selection** section.

- 4 Click  **Create Selection**.
- 5 In the **Create Selection** dialog, type Liner in the **Selection name** text field.
- 6 Click **OK**.
- 7 In the **Settings** window for **Solid Mechanics**, locate the **Thickness** section.
- 8 In the d text field, type L.



Contact I

- 1 In the **Model Builder** window, under **Component 1 (comp1) > Solid Mechanics (solid)** click **Contact 1**.
- 2 In the **Settings** window for **Contact**, locate the **Contact Pressure Penalty Factor** section.
- 3 From the **Penalty factor control** list, choose **Manual tuning**.
- 4 In the f_p text field, type 8.

Symmetry I

- 1 In the **Physics** toolbar, click  **Boundaries** and choose **Symmetry**.
- 2 Select Boundaries 9 and 10 only.

Enclosed Cavity, Inner Pressure

- 1 In the **Physics** toolbar, click  **Boundaries** and choose **Enclosed Cavity**.
- 2 In the **Settings** window for **Enclosed Cavity**, type Enclosed Cavity, Inner Pressure in the **Label** text field.
- 3 Locate the **Boundary Selection** section. From the **Selection** list, choose **Liner Inner Surface**.
- 4 Locate the **Volume Definition** section. From the **Volume type** list, choose **Open surface**.
- 5 Locate the **Reference Point** section. Click to select the  **Activate Selection** toggle button.
- 6 Select Point 11 only.
- 7 Locate the **Volume Definition** section. In the f_V text field, type 2.

Remove the **Fluid** node, and use a **Prescribed Pressure** node instead to apply a known pressure load on the liner's inner boundary.

Fluid I

In the **Model Builder** window, right-click **Fluid 1** and choose **Delete**.

Prescribed Pressure I

- 1 In the **Physics** toolbar, click  **Attributes** and choose **Prescribed Pressure**.
- 2 In the **Settings** window for **Prescribed Pressure**, locate the **Prescribed Pressure** section.

3 In the p text field, type 1[atm].

Next, model the cavity formed between the pipe and liner.

Enclosed Cavity, Outer Pressure

- 1 In the **Model Builder** window, right-click **Enclosed Cavity, Inner Pressure** and choose **Duplicate**.
- 2 In the **Settings** window for **Enclosed Cavity**, type Enclosed Cavity, Outer Pressure in the **Label** text field.
Select the **Pipe–Liner Cavity** to define the volume in between the pipe and liner. Notice that the pipe boundaries, which are not included in the **Solid Mechanics** interface, will be marked as "not applicable". These boundaries have to be explicitly allowed.
- 3 Locate the **Boundary Selection** section. From the **Selection** list, choose **Pipe–Liner Cavity**.
- 4 Click to expand the **Advanced** section. Select the **Include boundaries external to current physics** checkbox.

When including external boundaries, a normal direction has to be specified. By convention, the normal for external boundaries has to point toward the fluid. In this case, the normal of the referenced default boundary system is oriented correctly.

Prescribed Pressure I

- 1 In the **Model Builder** window, expand the **Enclosed Cavity, Outer Pressure** node, then click **Prescribed Pressure I**.
- 2 In the **Settings** window for **Prescribed Pressure**, locate the **Prescribed Pressure** section.
- 3 In the p text field, type $R_s \cdot \dot{m} \cdot T / \text{solid. enc2.V}$.

Hyperelastic Material I

- 1 In the **Physics** toolbar, click  **Domains** and choose **Hyperelastic Material**.
- 2 In the **Settings** window for **Hyperelastic Material**, locate the **Domain Selection** section.
- 3 From the **Selection** list, choose **Liner**.
- 4 Locate the **Hyperelastic Material** section. From the **Material model** list, choose **Arruda–Boyce**.
- 5 From the **Compressibility** list, choose **Compressible, uncoupled**.

Polymer Viscoplasticity I

- 1 In the **Physics** toolbar, click  **Attributes** and choose **Polymer Viscoplasticity**.
- 2 In the **Settings** window for **Polymer Viscoplasticity**, locate the **Viscoplasticity Model** section.
- 3 From the **Material model** list, choose **Bergstrom–Bischoff**.

- 4 Find the **Network 1** subsection. In the β_{v1} text field, type beta1.
- 5 Find the **Network 2** subsection. In the β_v, i text field, type beta2_i.
- 6 In the β_v, f text field, type beta2_f.
- 7 In the α text field, type alpha.
- 8 Locate the **Thermal Effects** section. From the $g(T)$ list, choose **Power law**.
- 9 In the m text field, type m.
- 10 Locate the **Model Input** section. From the T list, choose **User defined**. In the associated text field, type T.
- 11 Locate the **Thermal Effects** section. In the T_{ref} text field, type theta0.
- 12 Locate the **Time Stepping** section. From the **Method** list, choose **Domain ODEs**.

MATERIALS

HDPE

- 1 In the **Model Builder** window, under **Component 1 (comp1)** right-click **Materials** and choose **Blank Material**.
- 2 In the **Settings** window for **Material**, locate the **Geometric Entity Selection** section.
- 3 From the **Selection** list, choose **Liner**.
- 4 Locate the **Material Contents** section. In the table, enter the following settings:

Property	Variable	Value	Unit	Property group
Bulk modulus	K	2 [GPa]	N/m ²	Bulk modulus and shear modulus
Number of segments	Nseg	4.5	l	Arruda-Boyce
Macroscopic shear modulus	mu0	mu*(1+(T-theta0)/thetar)	N/m ²	Arruda-Boyce
Density	rho	950 [kg/m ³]	kg/m ³	Basic
Viscoplastic rate coefficient	A_BeBi	sqrt(2/3) [1/s]	l/s	Bergstrom-Bischoff viscoplasticity
Flow resistance	sigResI_BeBi	7.1 [MPa]	N/m ²	Bergstrom-Bischoff viscoplasticity
Stress exponent	nI_BeBi	13	l	Bergstrom-Bischoff viscoplasticity
Pressure hardening coefficient	aI_BeBi	0.183	l	Bergstrom-Bischoff viscoplasticity

Property	Variable	Value	Unit	Property group
Flow resistance	sigRes2_BeBi	32.2 [MPa]	N/m ²	Bergstrom-Bischoff viscoplasticity
Stress exponent	n2_BeBi	22.4	1	Bergstrom-Bischoff viscoplasticity
Pressure hardening coefficient	a2_BeBi	0.183	1	Bergstrom-Bischoff viscoplasticity

5 In the **Label** text field, type HDPE.

MESH 1

Mapped 1

- 1 In the **Mesh** toolbar, click  **Mapped**.
- 2 In the **Settings** window for **Mapped**, locate the **Domain Selection** section.
- 3 From the **Geometric entity level** list, choose **Domain**.
- 4 Select Domains 3 and 4 only.

Distribution 1

- 1 Right-click **Mapped 1** and choose **Distribution**.
- 2 Select Boundary 10 only.
- 3 In the **Settings** window for **Distribution**, locate the **Distribution** section.
- 4 In the **Number of elements** text field, type 2.

Distribution 2

- 1 In the **Model Builder** window, right-click **Mapped 1** and choose **Distribution**.
- 2 In the **Settings** window for **Distribution**, locate the **Boundary Selection** section.
- 3 From the **Selection** list, choose **Liner Inner Surface**.
- 4 Locate the **Distribution** section. In the **Number of elements** text field, type 25.
- 5 Click  **Build All**.

Mapped 2

- 1 In the **Mesh** toolbar, click  **Mapped**.
- 2 In the **Settings** window for **Mapped**, locate the **Domain Selection** section.
- 3 From the **Geometric entity level** list, choose **Domain**.
- 4 Select Domains 1 and 2 only.

Size 1

- 1 Right-click **Mapped 2** and choose **Size**.
- 2 In the **Settings** window for **Size**, locate the **Element Size** section.
- 3 From the **Predefined** list, choose **Finer**.
- 4 Click  **Build Selected**.

Add a **Stationary** step to compute consistent initial values for the **Time Dependent** step.

STUDY 1

Step 2: Stationary

- 1 In the **Study** toolbar, click  **Stationary**.
- 2 Drag and drop above **Step 2: Time Dependent**.
- 3 In the **Settings** window for **Stationary**, locate the **Physics and Variables Selection** section.
- 4 Select the **Modify model configuration for study step** checkbox.
- 5 In the tree, select **Component 1 (comp1) > Solid Mechanics (solid), Controls spatial frame > Enclosed Cavity, Outer Pressure > Prescribed Pressure 1**.
- 6 Right-click and choose **Disable**.

Use the **Instantaneous** stiffness of the Bergstrom–Bischoff model for the **Stationary** step.

SOLID MECHANICS (SOLID)

Polymer Viscoplasticity 1

- 1 In the **Model Builder** window, under **Component 1 (comp1) > Solid Mechanics (solid) > Hyperelastic Material 1** click **Polymer Viscoplasticity 1**.
- 2 In the **Settings** window for **Polymer Viscoplasticity**, locate the **Viscoplasticity Model** section.
- 3 Find the **Stiffness used in stationary studies** subsection. From the list, choose **Instantaneous**.

STUDY 1

Step 2: Time Dependent

- 1 In the **Model Builder** window, under **Study 1** click **Step 2: Time Dependent**.
- 2 In the **Settings** window for **Time Dependent**, locate the **Study Settings** section.
- 3 In the **Output times** text field, type range(0,5,20[*min*]).

Solution 1 (sol1)

- 1 In the **Study** toolbar, click  **Show Default Solver**.
- 2 In the **Model Builder** window, expand the **Solution 1 (sol1)** node.
- 3 In the **Model Builder** window, expand the **Study 1 > Solver Configurations > Solution 1 (sol1) > Dependent Variables 2** node, then click **Viscoplastic Strain Tensor, Local Coordinate System (comp1.solid.hmm1.pvp1.evp1)**.
- 4 In the **Settings** window for **Field**, locate the **Scaling** section.
- 5 From the **Method** list, choose **Manual**.
- 6 In the **Model Builder** window, under **Study 1 > Solver Configurations > Solution 1 (sol1) > Dependent Variables 2** click **Viscoplastic Strain Tensor, Local Coordinate System (comp1.solid.hmm1.pvp1.evp2)**.
- 7 In the **Settings** window for **Field**, locate the **Scaling** section.
- 8 From the **Method** list, choose **Manual**.
- 9 In the **Model Builder** window, under **Study 1 > Solver Configurations > Solution 1 (sol1) > Dependent Variables 2** click **Equivalent Viscoplastic Strain, Network 1 (comp1.solid.hmm1.pvp1.evp1)**.
- 10 In the **Settings** window for **Field**, locate the **Scaling** section.
- 11 From the **Method** list, choose **Manual**.
- 12 In the **Model Builder** window, under **Study 1 > Solver Configurations > Solution 1 (sol1) > Dependent Variables 2** click **Equivalent Viscoplastic Strain, Network 2 (comp1.solid.hmm1.pvp1.evp2)**.
- 13 In the **Settings** window for **Field**, locate the **Scaling** section.
- 14 From the **Method** list, choose **Manual**.
- 15 In the **Model Builder** window, under **Study 1 > Solver Configurations > Solution 1 (sol1)** click **Time-Dependent Solver 1**.
- 16 In the **Settings** window for **Time-Dependent Solver**, click to expand the **Time Stepping** section.
- 17 From the **Method** list, choose **BDF**.
- 18 In the **Model Builder** window, expand the **Study 1 > Solver Configurations > Solution 1 (sol1) > Time-Dependent Solver 1** node, then click **Fully Coupled 1**.
- 19 In the **Settings** window for **Fully Coupled**, click to expand the **Method and Termination** section.
- 20 In the **Minimum damping factor** text field, type 0.25.
- 21 In the **Maximum number of iterations** text field, type 20.

22 In the **Model Builder** window, under **Study 1 > Solver Configurations > Solution 1 (sol1)** right-click **Time-Dependent Solver 1** and choose **Stop Condition**.

23 In the **Settings** window for **Stop Condition**, locate the **Stop Expressions** section.

24 Click **+ Add**.

25 Right-click and choose **Paste**.

26 In the table, enter the following settings:

Stop expression	Stop if	Active	Description
comp1.solid.enc1.A/ comp1.solid.enc1.A_r ef<0.6	True (>=1)	√	Stop expression 1

Parametric Sweep

1 In the **Study** toolbar, click  **Parametric Sweep**.

2 In the **Settings** window for **Parametric Sweep**, locate the **Study Settings** section.

3 Click **+ Add**.

4 In the table, enter the following settings:

Parameter name	Parameter value list	Parameter unit
T (Temperature)	278.15 298.15 323.15	K

5 In the **Study** toolbar, click  **Get Initial Value**.

RESULTS

Mirror 2D 1

1 In the **Model Builder** window, expand the **Results > Datasets** node.

2 Right-click **Results > Datasets** and choose **More 2D Datasets > Mirror 2D**.

Displacement

1 In the **Settings** window for **2D Plot Group**, type **Displacement** in the **Label** text field.

2 Locate the **Data** section. From the **Dataset** list, choose **Mirror 2D 1**.

3 Click to expand the **Title** section. From the **Title type** list, choose **Manual**.

4 In the **Title** text area, type **Displacements [mm]**.

5 In the **Parameter indicator** text field, type **Time=eval(t) s, T=eval(T) K**.

6 Locate the **Plot Settings** section. Clear the **Plot dataset edges** checkbox.

Liner

- 1 In the **Model Builder** window, expand the **Displacement** node, then click **Surface 1**.
- 2 In the **Settings** window for **Surface**, type **Liner** in the **Label** text field.
- 3 Locate the **Expression** section. In the **Expression** text field, type **solid.disp**.
- 4 From the **Unit** list, choose **mm**.

Pipe

- 1 In the **Model Builder** window, right-click **Displacement** and choose **Line**.
- 2 In the **Settings** window for **Line**, type **Pipe** in the **Label** text field.
- 3 Locate the **Expression** section. In the **Expression** text field, type **1**.
- 4 Locate the **Coloring and Style** section. From the **Coloring** list, choose **Uniform**.
- 5 From the **Color** list, choose **From theme**.

Selection 1

- 1 Right-click **Pipe** and choose **Selection**.
- 2 In the **Settings** window for **Selection**, locate the **Selection** section.
- 3 From the **Selection** list, choose **Pipe Inner Surface**.

STUDY 1

Step 2: Time Dependent

- 1 In the **Model Builder** window, under **Study 1** click **Step 2: Time Dependent**.
- 2 In the **Settings** window for **Time Dependent**, click to expand the **Results While Solving** section.
- 3 Select the **Plot** checkbox.
- 4 From the **Update at** list, choose **Time steps taken by solver**.
- 5 In the **Model Builder** window, click **Study 1**.
- 6 In the **Settings** window for **Study**, locate the **Study Settings** section.
- 7 Clear the **Generate default plots** checkbox.
- 8 In the **Study** toolbar, click  **Compute**.

RESULTS

Mirror 2D 1

- 1 In the **Model Builder** window, under **Results > Datasets** click **Mirror 2D 1**.
- 2 In the **Settings** window for **Mirror 2D**, locate the **Data** section.

- 3 From the **Dataset** list, choose **Study 1/Parametric Solutions 1 (sol3)**.

Displacement

- 1 In the **Model Builder** window, under **Results** click **Displacement**.
- 2 In the **Settings** window for **2D Plot Group**, locate the **Data** section.
- 3 From the **Parameter value (T (K))** list, choose **278.15**.
- 4 In the **Displacement** toolbar, click  **Plot**.

Gas Pressure

- 1 In the **Results** toolbar, click  **ID Plot Group**.
- 2 In the **Settings** window for **ID Plot Group**, locate the **Data** section.
- 3 From the **Dataset** list, choose **Study 1/Parametric Solutions 1 (sol3)**.
- 4 In the **Label** text field, type Gas Pressure.
- 5 Click to expand the **Title** section. From the **Title type** list, choose **Manual**.
- 6 In the **Title** text area, type Gas Pressure.
- 7 Locate the **Plot Settings** section.
- 8 Select the **y-axis label** checkbox. In the associated text field, type Pressure (atm).



Global 1

- 1 Right-click **Gas Pressure** and choose **Global**.
- 2 In the **Settings** window for **Global**, click **Replace Expression** in the upper-right corner of the **y-Axis Data** section. From the menu, choose **Component 1 (comp1) > Solid Mechanics > Enclosed cavities > Enclosed Cavity, Outer Pressure > solid.enc2.pp1.p_rel - Relative pressure - Pa**.
- 3 Locate the **y-Axis Data** section. In the table, enter the following settings:

Expression	Unit	Description
solid.enc2.pp1.p_rel	atm	Relative pressure

- 4 Click to expand the **Coloring and Style** section. Find the **Line style** subsection. From the **Line** list, choose **Dashed**.
- 5 From the **Width** list, choose **2**.
- 6 Find the **Line markers** subsection. From the **Marker** list, choose **Asterisk**.
- 7 Click to expand the **Legends** section. Find the **Include** subsection. Clear the **Description** checkbox.
- 8 In the **Gas Pressure** toolbar, click  **Plot**.

Extrusion 2D I

- 1 In the **Results** toolbar, click  **More Datasets** and choose **Extrusion 2D**.
- 2 In the **Settings** window for **Extrusion 2D**, locate the **Data** section.
- 3 From the **Dataset** list, choose **Mirror 2D I**.
- 4 Locate the **Extrusion** section. In the **z maximum** text field, type 20[cm].
- 5 Find the **Embedding** subsection. From the **Map plane to** list, choose **yz-plane**.
- 6 Click  **Plot**.

3D Pipe and Liner

- 1 In the **Results** toolbar, click  **3D Plot Group**.
- 2 In the **Settings** window for **3D Plot Group**, type 3D Pipe and Liner in the **Label** text field.
- 3 Click to expand the **Title** section. From the **Title type** list, choose **Manual**.
- 4 In the **Parameter indicator** text field, type $\text{Time}=\text{eval}(t) \text{ s}$, $T=\text{eval}(T) \text{ K}$.
- 5 Locate the **Plot Settings** section. Clear the **Plot dataset edges** checkbox.

Volume I

- 1 Right-click **3D Pipe and Liner** and choose **Volume**.
- 2 In the **Settings** window for **Volume**, locate the **Expression** section.
- 3 In the **Expression** text field, type 1.
- 4 Locate the **Coloring and Style** section. From the **Coloring** list, choose **Uniform**.
- 5 In the **3D Pipe and Liner** toolbar, click  **Plot**.

Material Appearance I

- 1 Right-click **Volume I** and choose **Material Appearance**.
- 2 In the **Settings** window for **Material Appearance**, locate the **Appearance** section.
- 3 From the **Appearance** list, choose **Custom**.
- 4 Click the  **Go to Default View** button in the **Graphics** toolbar.
- 5 From the **Material type** list, choose **Rubber**.
- 6 From the **Color** list, choose **Gray**.

Liner

- 1 In the **Model Builder** window, under **Results > 3D Pipe and Liner** click **Volume I**.
- 2 In the **Settings** window for **Volume**, type Liner in the **Label** text field.

Deformation 1

- 1 Right-click **Liner** and choose **Deformation**.
- 2 In the **Settings** window for **Deformation**, locate the **Scale** section.
- 3 Select the **Scale factor** checkbox. In the associated text field, type 1.
- 4 Locate the **Expression** section. In the **x-component** text field, type 0.
- 5 In the **y-component** text field, type u.
- 6 In the **z-component** text field, type v.

Mirror 2D 2

In the **Model Builder** window, under **Results > Datasets** right-click **Mirror 2D 1** and choose **Duplicate**.

Selection

- 1 In the **Results** toolbar, click  **Attributes** and choose **Selection**.
- 2 In the **Settings** window for **Selection**, locate the **Geometric Entity Selection** section.
- 3 From the **Geometric entity level** list, choose **Domain**.
- 4 Select Domains 1 and 2 only.

Extrusion 2D 2



- 1 In the **Model Builder** window, under **Results > Datasets** right-click **Extrusion 2D 1** and choose **Duplicate**.
- 2 In the **Settings** window for **Extrusion 2D**, locate the **Data** section.
- 3 From the **Dataset** list, choose **Mirror 2D 2**.
- 4 Locate the **Extrusion** section. In the **z minimum** text field, type 5.

Pipe

- 1 In the **Model Builder** window, right-click **3D Pipe and Liner** and choose **Surface**.
- 2 In the **Settings** window for **Surface**, type Pipe in the **Label** text field.
- 3 Locate the **Data** section. From the **Dataset** list, choose **Extrusion 2D 2**.
- 4 From the **Solution parameters** list, choose **From parent**.
- 5 Locate the **Expression** section. In the **Expression** text field, type 1.
- 6 Locate the **Coloring and Style** section. From the **Coloring** list, choose **Uniform**.

Material Appearance 1

- 1 Right-click **Pipe** and choose **Material Appearance**.
- 2 In the **Settings** window for **Material Appearance**, locate the **Appearance** section.

- 3 From the **Appearance** list, choose **Custom**.
- 4 From the **Material type** list, choose **Steel (scratched)**.
- 5 Click the  **Show Grid** button in the **Graphics** toolbar.
- 6 In the **Graphics** window toolbar, click ▼ next to  **Scene Light**, then choose **Ambient Occlusion**.
- 7 In the **3D Pipe and Liner** toolbar, click  **Plot**.