



Model created in COMSOL Multiphysics 6.4

Biventricular Cardiac Model

Introduction

This example demonstrates how to simulate a cardiac contraction on a simplified heart geometry, where only the ventricles are considered and the stimulus starts from the atrioventricular node.

During the cardiac cycle (heartbeat) an electrical stimulus generated from the sino-atrial node propagates throughout the entire heart. When excited, cardiac cells are subjected to an electric potential jump across their membranes. The transport and accumulation of ions and additional chemical reactions cause cells to contract. At a macroscale these chemical and electrical processes trigger the contraction of the muscle tissue, the myocardium, allowing blood to be pumped to the arteries.

The muscle tissue (myocardium) is mainly composed of myocardial cells grouped in layered sheets that are aligned in a preferential direction (fibers). The fiber orientation strongly affects the mechanical and electrical tissue properties. This arrangement suggests that the cardiac tissue can be modeled as an anisotropic hyperelastic material.

The time and spatial evolution of the electric potential is described by the *Aliev-Panfilov* equations with a nonlinear current-voltage relation. This electrochemical model describes the quick rise of the cell's transmembrane electric potential (depolarization) and the return to its resting value (repolarization).

The tissue contraction in the hyperelastic model is obtained using an additive decomposition of the stress tensor. The actual contraction at the cellular level is taken into account by introducing an additional stress (active stress) in the Solid Mechanics interface. This additional stress is voltage dependent, and its evolution is described by additional partial differential equations.

Model Definition

The simplified heart geometry shown in [Figure 1](#) includes the two elliptical ventricular chambers. The atria are not considered.

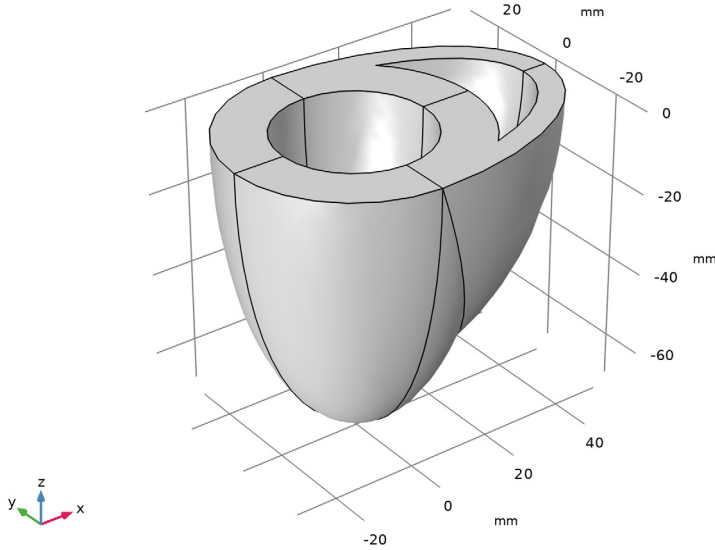

Figure 1: Geometry of the two ventricular chambers of the heart.

The base is located at $Z = 0$, and the left ventricle apex is located at $Z = -70$ mm. The ventricle dimensions are taken from [Ref. 2](#) and shown in [Table 1](#).

TABLE 1: LEFT AND RIGHT VENTRICLE DIMENSIONS.

Geometry	Left ventricle	Right ventricle
x-semiaxis (epicardium)	30 [mm]	51 [mm]
y-semiaxis (epicardium)	30 [mm]	30 [mm]
z-semiaxis (epicardium)	70 [mm]	60 [mm]
Thickness	12 [mm]	6 [mm]

The ventricular wall (myocardium) is surrounded by the epicardium on the outside ([Figure 2](#)) and by the endocardium on the inside ([Figure 3](#)). These are not included in the model, but these terms will refer to the walls boundaries that are in contact with the myocardium.

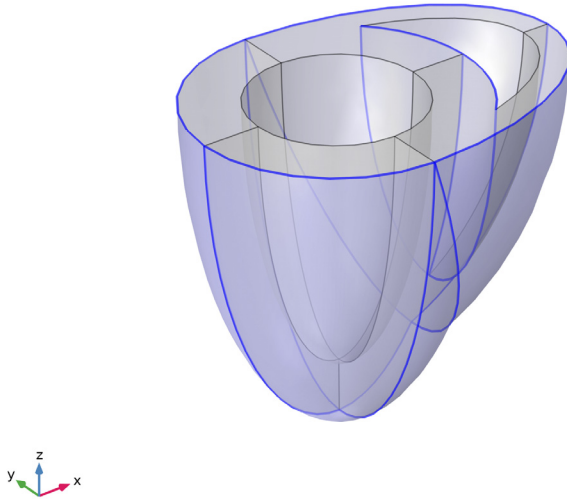

Figure 2: Boundaries in contact with the epicardium.

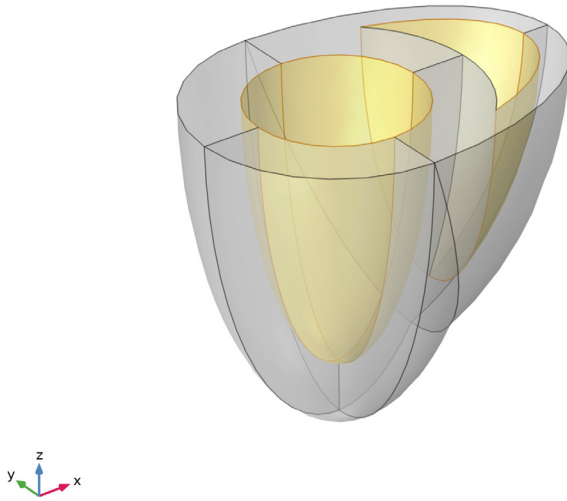

Figure 3: Boundaries in contact with the endocardium.

FIBER DIRECTION

The fibers have an inclination of 60° at the endocardium ($\theta_{\text{end}}^{\text{max}}$) and -60° at the epicardium ($\theta_{\text{epi}}^{\text{max}}$) with respect to the horizontal basal plane ($Z=0$). It is also assumed that the fibers' inclination goes to zero at the left ventricle apex ($Z_{\text{LV}}^{\text{apex}}$), so the expressions for the fiber angle on the myocardium boundaries read

$$\theta_{\text{epi}} = \theta_{\text{epi}}^{\text{max}} \left(1 - \frac{Z}{Z_{\text{LV}}^{\text{apex}}} \right)$$

$$\theta_{\text{end}} = \theta_{\text{end}}^{\text{max}} \left(1 - \frac{Z}{Z_{\text{LV}}^{\text{apex}}} \right)$$

Across the cardiac walls the fiber angle varies linearly as

$$\theta = \beta \theta_{\text{end}} + (1 - \beta) \theta_{\text{epi}}$$

where β is a dimensionless parameter representing the fiber distance to the epicardium boundary. It takes values between 0 (epicardium) and 1 (endocardium), and it is an expression based on the fiber distance to the epicardium, D_{epi} , and to the endocardium, D_{end} ,

$$\beta = \frac{D_{\text{epi}}}{D_{\text{epi}} + D_{\text{end}}} \quad (1)$$

The myocardium is modeled as an anisotropic hyperelastic material with three preferential directions: fiber direction (\mathbf{a}), sheet direction (\mathbf{s}), and normal to sheet direction (\mathbf{n}). This reference system can be approximated through a composition of coordinate systems.

The coordinate system used to define the material and electrical tissue properties is created in two steps. First, the transmural direction is obtained through the use of the **Curvilinear Coordinate** interface. It is assumed that the transmural direction coincides with the sheet direction (\mathbf{s}). The resulting curvilinear system has the first basis vector oriented in the sheet direction, and the second basis vector oriented toward the apico-basal direction (Figure 4).

Coordinate system volume: Base vector system

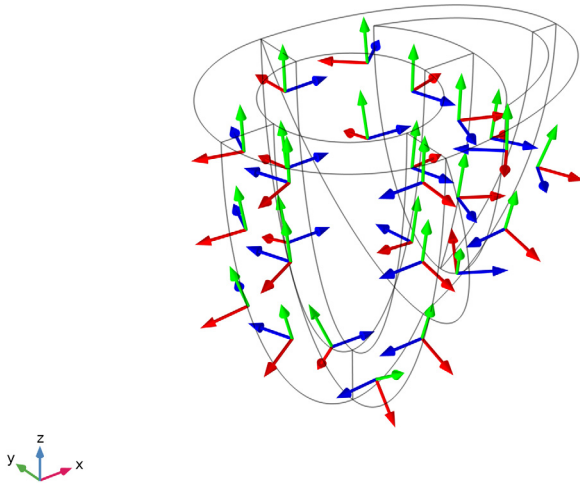

Figure 4: Intermediate coordinate system obtained with the Curvilinear Coordinate interface. The first basis vector (red) corresponds to the transmural direction. Note that the transmural direction coincides with the sheet direction in this example.

This intermediate coordinate system is rotated with an angle θ around the first basis vector (\mathbf{s}) to align the third axis along the fiber direction \mathbf{a} . The resulting fiber orientation is shown in [Figure 5](#).

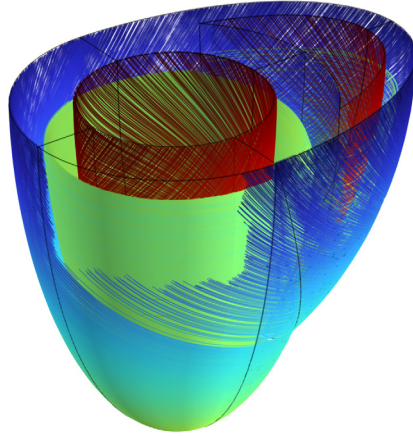

Figure 5: Fiber layout in the undeformed configuration. Note that the fiber angle changes along the transmural direction.

ELECTROPHYSIOLOGY MODEL

The electric potential Φ in the myocardium is described by the following equation (Ref. 1)

$$\chi_m C_m \frac{\partial}{\partial t} \Phi + \nabla \cdot (-D \nabla \Phi) + \chi_m [I_{\text{ion}}(\Phi, F, r_i)] = 0 \quad (2)$$

where χ_m is the membrane surface to volume ratio, C_m is the membrane capacitance, D is the conductivity tensor, I_{ion} is the ionic current per unit area, and F the deformation gradient. The ionic current depends on the potential, the deformation gradient, and other internal variables, r_i .

In this example, the ionic current is split into an excitation-induced, purely electrical part I_e , and a stretch-induced part I_m , as described in Ref. 2.

$$I_{\text{ion}}(\Phi, F, r_i) = I_e(\Phi, r_i) + I_m(F) \quad (3)$$

The *Aliev-Panfilov* equations (Ref. 3) are used to represent the purely electrical part of the ionic current, I_e , as a function of the electric potential. These equations use one additional internal variable, and they are usually expressed in dimensionless form:

$$\tilde{I}_e(v, r) = c\phi(\phi - \alpha)(\phi - 1) + r\phi$$

$$\frac{\partial r}{\partial \tau} = \left(\gamma + \frac{\mu_1}{\mu_2 + \phi} r \right) [-r - c\phi(\phi - b - 1)]$$

Here, ϕ is the dimensionless electric potential, τ is the dimensionless time, and r is an internal variable called *recovery variable*. Furthermore, c , α , γ , μ_1 , μ_2 , and b are material parameters whose values are taken from [Ref. 2](#) and can be found in [Table 2](#).

TABLE 2: MATERIAL PARAMETERS FOR THE ALIEV-PANFILOV EQUATION.

PARAMETER	VALUE
c	8
α	0.01
γ	0.002
μ_1	0.2
μ_2	0.3
b	0.15

The a stretch-induced electric current I_m is defined as

$$\tilde{I}_m(F) = \theta G_s(\lambda(F) - 1)(\phi - \phi_s)$$

where λ is the stretch in the fiber direction, G_s is the maximum conductance, ϕ_s is the resting electric potential for the ion channels, and θ is an activation parameter. This expression assumes the value of 1 when the fibers are stretched, and 0 when they are compressed. The values of the additional parameters are taken from [Ref. 2](#) and shown in [Table 3](#).

TABLE 3: STRETCH-INDUCED CURRENT PARAMETERS.

PARAMETER	VALUE
G_s	10
ϕ_s	0.6

A dimensional mapping of the ionic current equation ([Equation 3](#)) is used to match the experimental values of electric potential and activation time in the myocardium:

$$\Phi = \phi\beta_\phi + \delta_\phi$$

$$t = \beta_t \tau$$

Here, β_ϕ and δ_ϕ are selected to match experimental values: the resting potential of the heart is -80 mV and the maximum potential value is 20 mV.

The time scaling parameter β_t is considered to be dependent on the activation time t_a , which shows better agreement with experimental observations (see [Ref. 2](#) for details). During the cardiac cycle, the activation lapse (time between depolarization and repolarization) is not constant throughout the myocardium. Regions that are depolarized last are the first to repolarize. Therefore, the parameter β_t assumes the following expression

$$\beta_t = (12,9 \text{ ms}) \left(1 - \tau_0 \frac{t_a - t_0}{t_1 - t_0} \right) \quad (4)$$

where τ_0 , t_0 , and t_1 are tuning parameters ([Table 4](#)).

TABLE 4: TIME MAPPING PARAMETERS

PARAMETER	VALUE
τ_0	0.55
t_0	12[ms]
t_1	75[ms]

In this example, the activation time t_a depends on the Z coordinate and the vertical distance to the apex

$$t_a(X, Y, Z) = (50 \text{ ms}) \left(1 - \frac{Z}{Z_{LV}^{\text{apex}}} \right)$$

The dimensional ionic current is then obtained from dimensionless purely electric current $\tilde{I}_e(v, r)$, and stretch-induced current $\tilde{I}_m(F)$

$$I_{\text{ion}} = C_m \frac{\beta_\phi}{\beta_t} (\tilde{I}_e + \tilde{I}_m)$$

The conductivity tensor in [Equation 2](#) is decomposed into an isotropic part and an anisotropic part, which depends on the fiber direction ([Ref. 2](#))

$$D = (d_{\text{iso}} C_m \chi_m) I + (d_{\text{ani}} C_m \chi_m) \mathbf{a}_0 \otimes \mathbf{a}_0$$

where $d_{\text{iso}} = 1 \text{ mm}^2/\text{ms}$ and $d_{\text{ani}} = 0.1 \text{ mm}^2/\text{ms}$.

ACTIVE STRESS

The active stress component, s_a , is calculated by solving the following differential equation:

$$\frac{\partial s_a}{\partial t} = \varepsilon(V)[k(\Phi - \Phi_r) - s_a] \quad (5)$$

where ε is a delay function introduced in Ref. 2:

$$\varepsilon(V) = \varepsilon_0 + (\varepsilon_0 - \varepsilon_1) \exp(-\exp(-\zeta(\Phi - \Phi_t)))$$

Here, k , Φ_r , ε_0 , ε_1 , ζ , and Φ_t are taken from Ref. 2 and shown in Table 5.

TABLE 5: ACTIVE STRESS PARAMETERS.

PARAMETER	VALUE
k	0.005[MPa/mV]
ε_0	0.1[l/ms]
ε_1	1[l/ms]
ζ	1[l/mV]
Φ_r	-80[mV]
Φ_t	0[mV]

The active stress obtained from Equation 5 is added to the second Piola–Kirchhoff stress in different percentages along the fiber, sheet and normal directions as described in Ref. 1:

$$S = S + s_a(\mathbf{a}_0 \otimes \mathbf{a}_0) + 0,4s_a(\mathbf{s}_0 \otimes \mathbf{s}_0) + 0,4s_a(\mathbf{n}_0 \otimes \mathbf{n}_0) \quad (6)$$

MATERIAL MODEL

The cardiac tissue is considered to be hyperelastic, and the strain energy density is split into isotropic and anisotropic contributions

$$W = W_{\text{iso}} + W_{\text{ani}}$$

A compressible Neo–Hookean strain energy density is used for the isotropic part,

$$W_{\text{iso}} = \frac{1}{2}\mu(I_1 - 3) + \mu \log J_{\text{el}} + \frac{1}{2}\lambda(\log J_{\text{el}})^2$$

whereas the Holzapfel–Gasser–Ogden (HGO) model is used for the anisotropic contribution.

$$W_{\text{ani}} = \frac{k_1}{2k_2}(e^{k_2(\bar{I}_\alpha - 1)^2} - 1) \quad (7)$$

Here, k_1 and k_2 are material properties, and \bar{I}_α is the invariant of the isochoric Green–Cauchy strain tensor along the fiber direction:

$$\bar{I}_a = \bar{I}_a(\bar{C}_{el}, \mathbf{a}_0) = \mathbf{a}_0 \cdot \bar{C}_{el} \cdot \mathbf{a}_0 \quad (8)$$

The anisotropic hyperelastic parameters are given in [Table 6](#).

TABLE 6: MATERIAL PROPERTIES.

Material properties	Value
λ (Ref. 2)	0.5 [MPa]
μ (Ref. 2)	0.2 [MPa]
k_1 (Ref. 1)	1.685 [kPa]
k_2 (Ref. 1)	15.779

BOUNDARY AND INITIAL CONDITION

The following conditions are applied to simulate the ventricle contractions:

- The displacement of the basal surface is constrained.
- Zero flux boundary conditions are used in the additional equations for Φ , r , and s_a .
- An initial pulse of electric potential (-10 mV) is applied on a rectangular area on the basal surface between the ventricles ([Figure 6](#)).

Time=0 ms

Dependent variable Phi (mV)

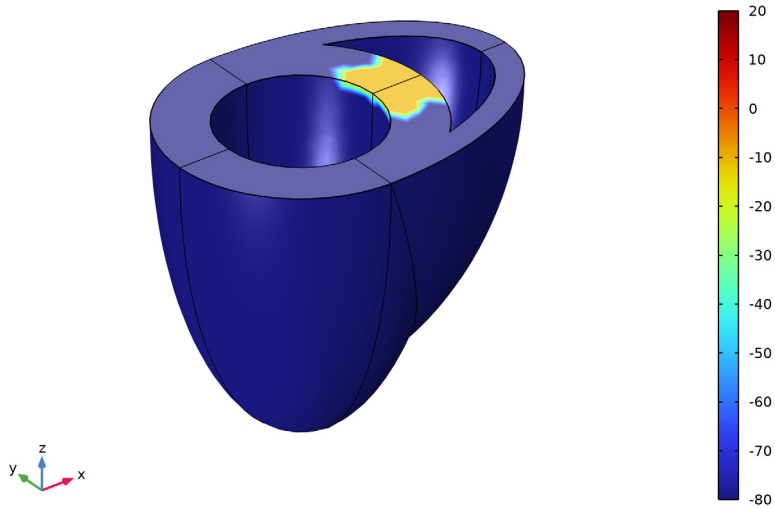

Figure 6: Initial impulse at the atrioventricular node.

Results and Discussion

The model computes the contraction of the myocardium due to an electric stimulus.

Figure 5 displays the fibers layout in the undeformed configuration.

Figure 7 shows the time variation of the electric potential distribution and the deformation of the cardiac walls. The depolarization of the cells produces an active stress that causes the myocardium to contract. There is an upward motion of the apex and a small torsion of the ventricles. The heart returns to its original state after 300 ms.

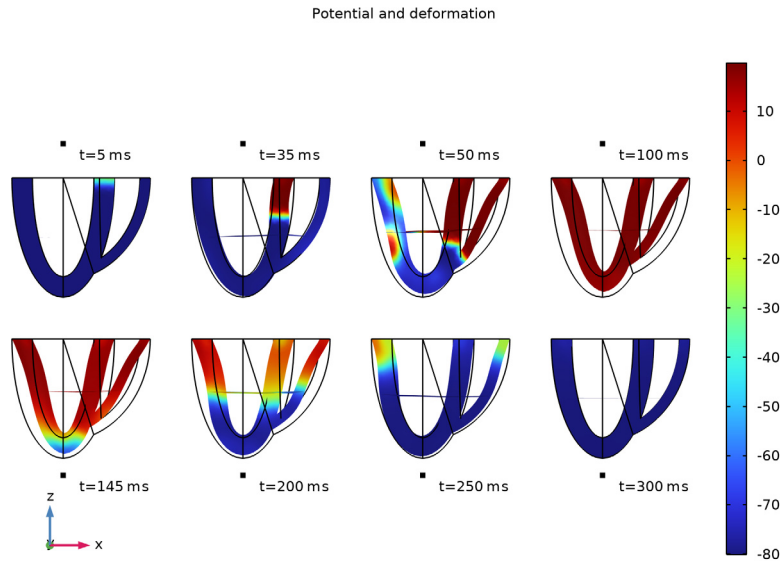

Figure 7: Depolarization and repolarization of the cardiac walls at different times during the cardiac cycle.

Figure 8 shows the activation potential at three different points. Note that the last cells to depolarize are the first ones to repolarize. This effect is achieved by manipulating the dimensionless time constant as shown in Equation 4.

Figure 9 shows the internal volume variation of the left and right ventricles. Both chambers contract during the depolarization of the excited myocardial cells, thus reducing the internal volume. Then, the ventricles gradually return to their initial configuration to be again excited during the next heartbeat.

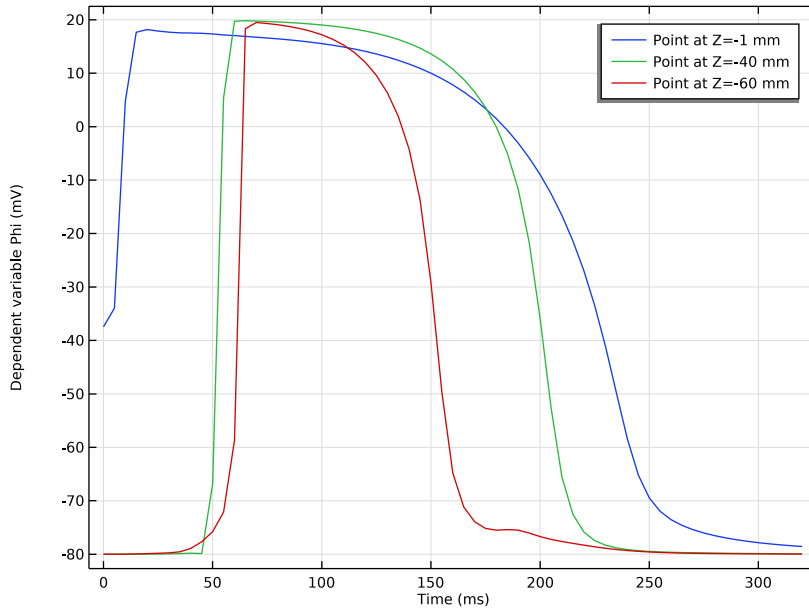

Figure 8: Plot of the activation duration at different locations.

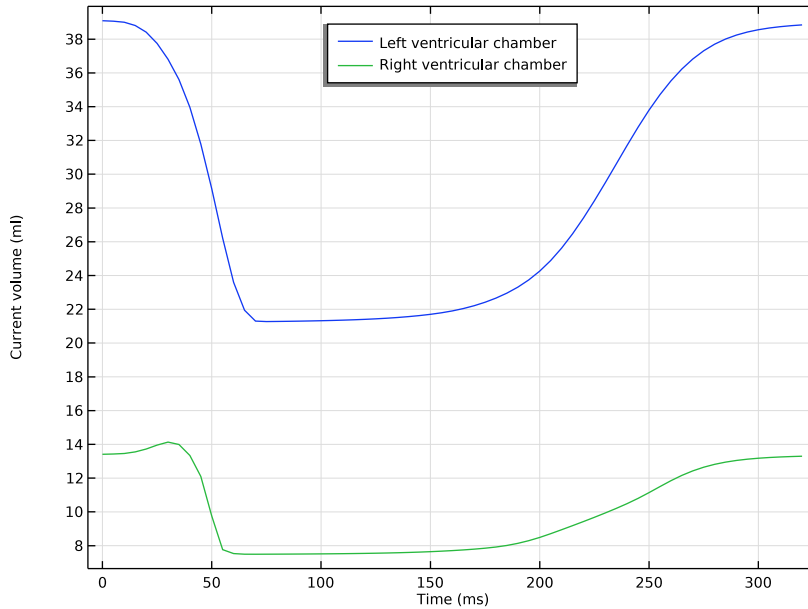

Figure 9: Volume variation of the left and right ventricular chambers.

References

1. A.A. Bakir, A.A. Abed, M.C. Stevens, N.H. Lovell, and S. Dokos, “A Multiphysics Biventricular Cardiac Model: Simulations With a Left-Ventricular Assist Device,” *Front. Physiol.*, vol. 9, p. 1259, 2018.
2. S. Göktepe and E. Kuhl, “Electromechanics of the heart: a unified approach to the strongly coupled excitation-contraction problem,” *Comput. Mech.*, vol. 45, pp. 227–243, 2010.
3. M.P. Nash and A.V. Panfilov, “Electromechanical model of excitable tissue to study reentrant cardiac arrhythmias,” *Prog. Biophys. Mol. Biol.*, vol. 85, pp. 501–522, 2004.

The analysis is performed in two separated studies. In the first study the fiber orientation is computed. In a second study, the cardiac contraction following an electrical excitation is analyzed. In particular, the following steps are taken:

- The fibers paths are computed using the **Wall Distance** and **Curvilinear Coordinate** interfaces.
- The contribution of the electrophysiology model (PDE interfaces) is included in the Solid Mechanics interface through the **External Stress** feature.
- The **Fiber** feature is set up using the curvilinear fiber orientation.
- The fiber pattern is displayed for postprocessing.

The distances D_{epi} and D_{endo} used in [Equation 1](#) to compute the dimensionless parameter β are determined by two **Wall Distance** interfaces. In one case the wall represents the endocardium, and in the other it represents the epicardium.

Inertial terms are neglected as reported in [Ref. 2](#). The **Structural Transient Behavior** is set to **Quasistatic** in the **Solid Mechanics** interface setting.

The active stress ([Equation 6](#)) is added to the total stress with the **External Stress** feature. The fiber coordinate system is selected in the **Coordinate System Selection** section.

In the settings for the **Fiber** feature, select the appropriate **Fiber Reference System** as a reference coordinate system. Then, in the **Orientation** section, select the orientation of the fiber (\mathbf{a}_0) to be aligned with the **third axis**.

The **Fiber** feature automatically computes the corresponding invariants, for instance I_a as used in [Equation 8](#), in order to compute the strain energy function W_{ani} as in [Equation 7](#).

The option **Stiffness in tension only** is activated by default for the HGO model, and it evaluates the fibers' strain energy to zero if the fiber stretch is in compression. This means that the fibers contribute to tensile stresses only.

The model parameters taken from literature references already include the effect of the membrane surface to volume ratio, χ_m , and the membrane capacitance, C_m . For this reason, these two parameters are set equal to 1 in this example.

The internal volume of the two ventricles is computed through the **Enclosed Cavity** feature.

Application Library path: Nonlinear_Structural_Materials_Module/
Hyperelasticity/biventricular_cardiac_model



Modeling Instructions

From the **File** menu, choose **New**.

NEW



In the **New** window, click  **Model Wizard**.

MODEL WIZARD

- 1 In the **Model Wizard** window, click  **3D**.
- 2 In the **Select Physics** tree, select **Mathematics** > **Wall Distance (wd)**.
- 3 Click **Add**.
- 4 Click **Add**.
- 5 In the **Select Physics** tree, select **Mathematics** > **Curvilinear Coordinates (cc)**.
- 6 Click **Add**.
- 7 Click  **Study**.
- 8 In the **Select Study** tree, select **General Studies** > **Stationary**.
- 9 Click  **Done**.

GEOMETRY I

Set Geometry representation to **COMSOL kernel** to build the geometry correctly.

- 1 In the **Geometry** toolbar, click **Insert Sequence** and choose **Insert Sequence**.
- 2 Browse to the model's Application Libraries folder and double-click the file `biventricular_cardiac_model_geom_sequence.mph`.
- 3 In the **Geometry** toolbar, click  **Build All**.
- 4 Click the  **Go to Default View** button in the **Graphics** toolbar.

Complete geometry instructions can be found in the [Appendix — Geometry Modeling Instructions](#) section.

GLOBAL DEFINITIONS



Heart Geometry Parameters

- 1 In the **Model Builder** window, under **Global Definitions** click **Parameters 1**.
- 2 In the **Settings** window for **Parameters**, type Heart Geometry Parameters in the **Label** text field.

DEFINITIONS

Create selections to identify the basal surface, the epicardium and the endocardium.

Basal Surface

- 1 In the **Definitions** toolbar, click  **Explicit**.
- 2 In the **Settings** window for **Explicit**, type Basal Surface in the **Label** text field.
- 3 Locate the **Input Entities** section. From the **Geometric entity level** list, choose **Boundary**.
- 4 Click the  **Transparency** button in the **Graphics** toolbar.
- 5 Select Boundaries 1, 3, 9, and 17 only.

LV-Endocardium

- 1 In the **Definitions** toolbar, click  **Explicit**.
- 2 In the **Settings** window for **Explicit**, type LV-Endocardium in the **Label** text field.
- 3 Locate the **Input Entities** section. From the **Geometric entity level** list, choose **Boundary**.
- 4 Select Boundaries 6, 7, 12, and 16 only.

RV-Endocardium

- 1 In the **Definitions** toolbar, click  **Explicit**.
- 2 In the **Settings** window for **Explicit**, type RV-Endocardium in the **Label** text field.
- 3 Locate the **Input Entities** section. From the **Geometric entity level** list, choose **Boundary**.
- 4 Select Boundaries 20 and 22 only.

Epicardium

- 1 In the **Definitions** toolbar, click  **Explicit**.
- 2 In the **Settings** window for **Explicit**, type Epicardium in the **Label** text field.
- 3 Locate the **Input Entities** section. From the **Geometric entity level** list, choose **Boundary**.
- 4 Select Boundaries 4, 5, 10, 11, 15, 18, 19, and 21 only.

Endocardium

- 1 In the **Definitions** toolbar, click  **Union**.
- 2 In the **Settings** window for **Union**, type Endocardium in the **Label** text field.

- 3 Locate the **Geometric Entity Level** section. From the **Level** list, choose **Boundary**.
- 4 Locate the **Input Entities** section. Under **Selections to add**, click **+ Add**.
- 5 In the **Add** dialog, in the **Selections to add** list, choose **LV-Endocardium** and **RV-Endocardium**.
- 6 Click **OK**.

GLOBAL DEFINITIONS

Structural Mechanics Parameters

- 1 In the **Home** toolbar, click **Pi Parameters** and choose **Add > Parameters**.
- 2 In the **Settings** window for **Parameters**, type Structural Mechanics Parameters in the **Label** text field.
- 3 Locate the **Parameters** section. Click  **Load from File**.
- 4 Browse to the model's Application Libraries folder and double-click the file `biventricular_cardiac_model_mechanical_passive_parameters.txt`.

Electrical Parameters

- 1 In the **Home** toolbar, click **Pi Parameters** and choose **Add > Parameters**.
- 2 In the **Settings** window for **Parameters**, type Electrical Parameters in the **Label** text field.
- 3 Locate the **Parameters** section. Click  **Load from File**.
- 4 Browse to the model's Application Libraries folder and double-click the file `biventricular_cardiac_model_electrical_parameters.txt`.

Active Stress Parameters

- 1 In the **Home** toolbar, click **Pi Parameters** and choose **Add > Parameters**.
- 2 In the **Settings** window for **Parameters**, type Active Stress Parameters in the **Label** text field.
- 3 Locate the **Parameters** section. Click  **Load from File**.
- 4 Browse to the model's Application Libraries folder and double-click the file `biventricular_cardiac_model_active_stress_parameters.txt`.

Conversion Factors Parameters

- 1 In the **Home** toolbar, click **Pi Parameters** and choose **Add > Parameters**.
- 2 In the **Settings** window for **Parameters**, type Conversion Factors Parameters in the **Label** text field.
- 3 Locate the **Parameters** section. Click  **Load from File**.

- 4 Browse to the model's Application Libraries folder and double-click the file `biventricular_cardiac_model_conversion_parameters.txt`.

To compute the orientation of the fibers in any point in the myocardium it is necessary to know its distance from both the epicardium and the endocardium.

WALL DISTANCE: EPICARDIUM

- 1 In the **Model Builder** window, under **Component 1 (comp1)** click **Wall Distance (wd)**.
- 2 In the **Settings** window for **Wall Distance**, type Wall Distance: Epicardium in the **Label** text field.

Wall 1

- 1 In the **Physics** toolbar, click  **Boundaries** and choose **Wall**.
- 2 In the **Settings** window for **Wall**, locate the **Boundary Selection** section.
- 3 From the **Selection** list, choose **Epicardium**.

WALL DISTANCE: ENDOCARDIUM

- 1 In the **Model Builder** window, under **Component 1 (comp1)** click **Wall Distance 2 (wd2)**.
- 2 In the **Settings** window for **Wall Distance**, type Wall Distance: Endocardium in the **Label** text field.
- 3 In the **Physics** toolbar, click  **Boundaries** and choose **Wall**.
- 1 In the **Settings** window for **Wall**, locate the **Boundary Selection** section.
- 2 From the **Selection** list, choose **Endocardium**.

Assuming that the sheets are oriented perpendicularly to the wall, their direction can be found by computing the transmural direction.

SHEET DIRECTION

- 1 In the **Model Builder** window, under **Component 1 (comp1)** click **Curvilinear Coordinates (cc)**.
- 2 In the **Settings** window for **Curvilinear Coordinates**, type Sheet Direction in the **Label** text field.
- 3 Locate the **Settings** section. Select the **Create base vector system** checkbox.

Coordinate System Settings 1

- 1 In the **Model Builder** window, under **Component 1 (comp1)** > **Sheet Direction (cc)** click **Coordinate System Settings 1**.
- 2 In the **Settings** window for **Coordinate System Settings**, locate the **Settings** section.

- 3 From the **Second basis vector** list, choose **z-axis**.

Diffusion Method 1

In the **Physics** toolbar, click  **Domains** and choose **Diffusion Method**.

Inlet 1

- 1 In the **Physics** toolbar, click  **Attributes** and choose **Inlet**.
- 2 In the **Settings** window for **Inlet**, locate the **Boundary Selection** section.
- 3 From the **Selection** list, choose **Endocardium**.

Diffusion Method 1

In the **Model Builder** window, click **Diffusion Method 1**.

Outlet 1

- 1 In the **Physics** toolbar, click  **Attributes** and choose **Outlet**.
- 2 In the **Settings** window for **Outlet**, locate the **Boundary Selection** section.
- 3 From the **Selection** list, choose **Epicardium**.

MESH 1

- 1 In the **Model Builder** window, under **Component 1 (comp1)** click **Mesh 1**.
- 2 In the **Settings** window for **Mesh**, locate the **Physics-Controlled Mesh** section.
- 3 From the **Element size** list, choose **Finer**.
- 4 Click  **Build All**.

The first study is used to obtain the sheets' direction and the distance from the walls. These quantities can be used to find the fibers' direction.

STUDY: FIBER DIRECTION

- 1 In the **Model Builder** window, click **Study 1**.
- 2 In the **Settings** window for **Study**, type Study: Fiber Direction in the **Label** text field.
- 3 In the **Study** toolbar, click  **Compute**.

RESULTS

Wall Distance: Epicardium

In the **Settings** window for **3D Plot Group**, type Wall Distance: Epicardium in the **Label** text field.

Wall Distance: Endocardium

- 1 In the **Model Builder** window, under **Results** click **3D Plot Group 2**.

- 2 In the **Settings** window for **3D Plot Group**, type Wall Distance: Endocardium in the **Label** text field.

Coordinate system (cc), Vector Field (cc), Wall Distance: Endocardium, Wall Distance: Epicardium

- 1 In the **Model Builder** window, under **Results**, Ctrl-click to select **Wall Distance: Epicardium, Wall Distance: Endocardium, Vector Field (cc), and Coordinate system (cc)**.
- 2 Right-click and choose **Group**.

Study: Fiber Direction

In the **Settings** window for **Group**, type Study: Fiber Direction in the **Label** text field.
Add variables related to the fibers orientation.

DEFINITIONS

Fiber Orientation

- 1 In the **Model Builder** window, under **Component 1 (comp1)** right-click **Definitions** and choose **Variables**.
- 2 In the **Settings** window for **Variables**, type Fiber Orientation in the **Label** text field.
- 3 Locate the **Variables** section. Click  **Load from File**.
- 4 Browse to the model's Application Libraries folder and double-click the file `biventricular_cardiac_model_fibers.txt`.

The fibers reference system is obtained by rotating the curvilinear coordinate system found in the previous study.

Rotated System 2 (sys2)

- 1 In the **Definitions** toolbar, click  **Coordinate Systems** and choose **Rotated System**.
- 2 In the **Settings** window for **Rotated System**, locate the **Rotation** section.
- 3 Find the **Euler angles** subsection. In the β text field, type theta.

Fiber Reference System

- 1 In the **Definitions** toolbar, click  **Coordinate Systems** and choose **Composite System**.
- 2 In the **Settings** window for **Composite System**, type Fiber Reference System in the **Label** text field.
- 3 Locate the **Input Systems** section. From the **Base system** list, choose **Curvilinear System (cc) (cc_cs)**.
- 4 From the **Relative system** list, choose **Rotated System 2 (sys2)**.

Create a cylindrical system for postprocessing purposes.

Cylindrical System 4 (sys4)

- 1 In the **Definitions** toolbar, click  **Coordinate Systems** and choose **Cylindrical System**.
- 2 In the **Settings** window for **Cylindrical System**, locate the **Coordinate Names** section.
- 3 From the **Frame** list, choose **Material (X, Y, Z)**.

*Boundary System 1 (sys1), Curvilinear System (cc) (cc_cs), Cylindrical System 4 (sys4),
Fiber Reference System (sys3), Rotated System 2 (sys2)*

- 1 In the **Model Builder** window, under **Component 1 (comp1) > Definitions**, Ctrl-click to select **Boundary System 1 (sys1)**, **Curvilinear System (cc) (cc_cs)**, **Rotated System 2 (sys2)**, **Fiber Reference System (sys3)**, and **Cylindrical System 4 (sys4)**.
- 2 Right-click and choose **Group**.

Coordinate Systems

- 1 In the **Settings** window for **Group**, type **Coordinate Systems** in the **Label** text field.
- 2 In the **Model Builder** window, collapse the **Coordinate Systems** node.

Now we have all information needed to simulate the contraction. Add a Solid Mechanics interface and three PDE interfaces. The three PDEs will be used to solve the monodomain equation and to compute the active stress.

ADD PHYSICS

- 1 In the **Home** toolbar, click  **Add Physics** to open the **Add Physics** window.
- 2 Go to the **Add Physics** window.
- 3 In the tree, select **Structural Mechanics > Solid Mechanics (solid)**.
- 4 Find the **Physics interfaces in study** subsection. In the table, clear the **Solve** checkbox for **Study: Fiber Direction**.
- 5 Click the **Add to Component 1** button in the window toolbar.
- 6 In the tree, select **Mathematics > PDE Interfaces > Coefficient Form PDE (c)**.
- 7 In the table, clear the **Solve** checkbox for **Study: Fiber Direction**.
- 8 Click the **Add to Component 1** button in the window toolbar.
- 9 In the tree, select **Mathematics > PDE Interfaces > Coefficient Form PDE (c)**.
- 10 In the table, clear the **Solve** checkbox for **Study: Fiber Direction**.
- 11 Click the **Add to Component 1** button in the window toolbar.
- 12 In the tree, select **Mathematics > PDE Interfaces > Coefficient Form PDE (c)**.
- 13 In the table, clear the **Solve** checkbox for **Study: Fiber Direction**.

14 Click the **Add to Component 1** button in the window toolbar.

15 In the **Home** toolbar, click  **Add Physics** to close the **Add Physics** window.

SOLID MECHANICS (SOLID)

1 In the **Settings** window for **Solid Mechanics**, locate the **Structural Transient Behavior** section.

2 From the list, choose **Quasistatic**.

3 Click to expand the **Discretization** section. From the **Displacement field** list, choose **Linear**.

Hyperelastic Material 1

1 In the **Physics** toolbar, click  **Domains** and choose **Hyperelastic Material**.

2 In the **Settings** window for **Hyperelastic Material**, locate the **Domain Selection** section.

3 From the **Selection** list, choose **All domains**.

Fiber 1

In the **Physics** toolbar, click  **Attributes** and choose **Fiber**.

MATERIALS

Material 1 (mat1)

1 In the **Model Builder** window, under **Component 1 (comp1)** right-click **Materials** and choose **Blank Material**.

2 In the **Settings** window for **Material**, locate the **Material Contents** section.

3 In the table, enter the following settings:

Property	Variable	Value	Unit	Property group
Lamé parameter λ	lambLame	lambda_lame	N/m ²	Lamé parameters
Lamé parameter μ	muLame	mu_lame	N/m ²	Lamé parameters
Density	rho	rhos	kg/m ³	Basic
Fiber stiffness	k1HGO	af	Pa	Holzapfel-Gasser-Ogden
Model parameter	k2HGO	bf	l	Holzapfel-Gasser-Ogden
Fiber dispersion	k3HGO	0	l	Holzapfel-Gasser-Ogden

ELECTROPHYSIOLOGY: TRANSMEMBRANE POTENTIAL (PHI)

- 1 In the **Model Builder** window, under **Component 1 (comp1)** click **Coefficient Form PDE (c)**.
- 2 In the **Settings** window for **Coefficient Form PDE**, type Electrophysiology: Transmembrane Potential (Phi) in the **Label** text field.
- 3 Locate the **Units** section. Click  **Select Dependent Variable Quantity**.
- 4 In the **Physical Quantity** dialog, type electricpotential in the text field.
- 5 In the tree, select **Electromagnetics > Electric potential (V)**.
- 6 Click **OK**.
- 7 In the **Settings** window for **Coefficient Form PDE**, locate the **Units** section.
- 8 In the **Source term quantity** table, enter the following settings:

Source term quantity	Unit
Custom unit	A/m ³

- 9 Click to expand the **Discretization** section. From the **Element order** list, choose **Linear**.
- 10 From the **Frame** list, choose **Material**.
- 11 Click to expand the **Dependent Variables** section. In the **Field name (V)** text field, type Phi.
- 12 In the **Dependent variables (V)** table, enter the following settings:

Phi

ELECTROPHYSIOLOGY: CONDUCTANCE OF SLOW PROCESSES (R)

- 1 In the **Model Builder** window, under **Component 1 (comp1)** click **Coefficient Form PDE 2 (c2)**.
- 2 In the **Settings** window for **Coefficient Form PDE**, type Electrophysiology: Conductance of Slow Processes (r) in the **Label** text field.
- 3 Locate the **Units** section. In the **Source term quantity** table, enter the following settings:

Source term quantity	Unit
Custom unit	1/s

- 4 Locate the **Discretization** section. From the **Element order** list, choose **Linear**.
- 5 From the **Frame** list, choose **Material**.
- 6 Locate the **Dependent Variables** section. In the **Field name (I)** text field, type r.

7 In the **Dependent variables (I)** table, enter the following settings:

r

ACTIVE STRESS (SA)

- 1 In the **Model Builder** window, under **Component 1 (comp1)** click **Coefficient Form PDE 3 (c3)**.
- 2 In the **Settings** window for **Coefficient Form PDE**, type Active Stress (Sa) in the **Label** text field.
- 3 Locate the **Units** section. Click  **Select Dependent Variable Quantity**.
- 4 In the **Physical Quantity** dialog, type stress in the text field.
- 5 In the tree, select **Solid Mechanics > Stress tensor (N/m²)**.
- 6 Click **OK**.
- 7 In the **Settings** window for **Coefficient Form PDE**, locate the **Units** section.
- 8 In the **Source term quantity** table, enter the following settings:

Source term quantity	Unit
Custom unit	N/m ² /s

- 9 Locate the **Discretization** section. From the **Element order** list, choose **Linear**.
- 10 From the **Frame** list, choose **MATERIAL**.
- 11 Locate the **Dependent Variables** section. In the **Field name (N/m²)** text field, type Sa.
- 12 In the **Dependent variables (N/m²)** table, enter the following settings:

Sa

DEFINITIONS

Electrophysiology Variables

- 1 In the **Model Builder** window, under **Component 1 (comp1)** right-click **Definitions** and choose **Variables**.
- 2 In the **Settings** window for **Variables**, type Electrophysiology Variables in the **Label** text field.
- 3 Locate the **Variables** section. Click  **Load from File**.
- 4 Browse to the model's Application Libraries folder and double-click the file `biventricular_cardiac_model_electrophysiology.txt`.

Define the partial differential equations to solve in order to obtain the active stress.

ELECTROPHYSIOLOGY: TRANSMEMBRANE POTENTIAL (PHI) (C)

Coefficient Form PDE I

- 1 In the **Model Builder** window, under **Component 1 (comp1)** > **Electrophysiology: Transmembrane Potential (Phi) (c)** click **Coefficient Form PDE I**.
- 2 In the **Settings** window for **Coefficient Form PDE**, locate the **Diffusion Coefficient** section.
- 3 From the list, choose **Symmetric**.
- 4 Specify the c matrix as

D_iso+DfibXX	DfibXY	DfibXZ
DfibXY	D_iso+DfibYY	DfibYZ
DfibXZ	DfibYZ	D_iso+DfibZZ

- 5 Locate the **Source Term** section. In the f text field, type $-\text{Chi}_m \cdot (\text{Ie} + \text{Im})$.
- 6 Locate the **Damping or Mass Coefficient** section. In the d_a text field, type $\text{Chi}_m \cdot \text{Cm}$.

Initial Values I

- 1 In the **Model Builder** window, click **Initial Values I**.
- 2 In the **Settings** window for **Initial Values**, locate the **Initial Values** section.
- 3 In the Phi text field, type $\text{Phi}_r + 70[\text{mV}] \cdot (\text{Z} > -1\text{e}-4[\text{mm}]) \cdot (\text{X} < 31[\text{mm}]) \cdot (\text{X} > 0[\text{mm}]) \cdot (\text{Y} > -10[\text{mm}]) \cdot (\text{Y} < 10[\text{mm}])$.

ELECTROPHYSIOLOGY: CONDUCTANCE OF SLOW PROCESSES (R) (C2)

Coefficient Form PDE I

- 1 In the **Model Builder** window, under **Component 1 (comp1)** > **Electrophysiology: Conductance of Slow Processes (r) (c2)** click **Coefficient Form PDE I**.
- 2 In the **Settings** window for **Coefficient Form PDE**, locate the **Diffusion Coefficient** section.
- 3 In the c text field, type 0.
- 4 Locate the **Absorption Coefficient** section. In the a text field, type $(1/\text{betat}) \cdot (\text{gamma} + \text{mu}1 / (\text{phi} + \text{mu}2)) \cdot \text{c} \cdot \text{phi} \cdot (\text{phi} - \text{b} - 1)$.
- 5 Locate the **Source Term** section. In the f text field, type $(1/\text{betat}) \cdot (-\text{gamma} \cdot \text{c} \cdot \text{phi} \cdot (\text{phi} - \text{b} - 1) - \text{mu}1 / (\text{phi} + \text{mu}2) \cdot \text{r}^2)$.

ACTIVE STRESS (SA) (C3)

- 1 In the **Model Builder** window, under **Component 1 (comp1) > Active Stress (Sa) (c3)** click **Coefficient Form PDE 1**.
- 2 In the **Settings** window for **Coefficient Form PDE**, locate the **Diffusion Coefficient** section.
- 3 In the c text field, type 0.
- 4 Locate the **Absorption Coefficient** section. In the a text field, type `eps_delay`.
- 5 Locate the **Source Term** section. In the f text field, type `eps_delay*kT*(Phi-Phir)`.

SOLID MECHANICS (SOLID)

Fiber 1

- 1 In the **Model Builder** window, under **Component 1 (comp1) > Solid Mechanics (solid) > Hyperelastic Material 1** click **Fiber 1**.
- 2 In the **Settings** window for **Fiber**, locate the **Coordinate System Selection** section.
- 3 From the **Coordinate system** list, choose **Fiber Reference System (sys3)**.
- 4 Locate the **Distribution and Orientation** section. From the **a** list, choose **Third axis**.

The coupling between the potential and the deformation is obtained through the active stress. The active stress is added as an external stress. Use the fiber coordinate system to easily input the components.

Hyperelastic Material 1

In the **Model Builder** window, click **Hyperelastic Material 1**.

External Stress 1

- 1 In the **Physics** toolbar, click  **Attributes** and choose **External Stress**.
- 2 In the **Settings** window for **External Stress**, locate the **Coordinate System Selection** section.
- 3 From the **Coordinate system** list, choose **Fiber Reference System (sys3)**.
- 4 Locate the **External Stress** section. From the list, choose **Diagonal**.
- 5 Specify the S_{ext} matrix as

$v_s * S_a$	0	0
0	$v_n * S_a$	0
0	0	$v_f * S_a$

Prescribed Displacement 1

- 1 In the **Physics** toolbar, click  **Boundaries** and choose **Prescribed Displacement**.

- 2 In the **Settings** window for **Prescribed Displacement**, locate the **Boundary Selection** section.
- 3 From the **Selection** list, choose **Basal Surface**.
- 4 Locate the **Prescribed Displacement** section. From the **Displacement in x direction** list, choose **Prescribed**.
- 5 From the **Displacement in y direction** list, choose **Prescribed**.
- 6 From the **Displacement in z direction** list, choose **Prescribed**.

Add two **Enclosed Cavity** nodes to compute the internal volumes of the left and right chambers during contraction using Gauss's law. Since no internal fluid pressure is modeled, remove the **Fluid** subnode.

Enclosed Cavity 1

In the **Physics** toolbar, click  **Boundaries** and choose **Enclosed Cavity**.

Fluid 1

In the **Model Builder** window, right-click **Fluid 1** and choose **Delete**.

Enclosed Cavity: Left Ventricle

- 1 In the **Settings** window for **Enclosed Cavity**, type Enclosed Cavity: Left Ventricle in the **Label** text field.
- 2 Locate the **Boundary Selection** section. From the **Selection** list, choose **LV-Endocardium**.
- 3 Locate the **Volume Definition** section. From the **Volume type** list, choose **Open surface**.
- 4 Locate the **Reference Point** section. Click to select the  **Activate Selection** toggle button.
- 5 Select Point 2 only.

Enclosed Cavity: Right Ventricle

- 1 Right-click **Enclosed Cavity: Left Ventricle** and choose **Duplicate**.
- 2 In the **Settings** window for **Enclosed Cavity**, type Enclosed Cavity: Right Ventricle in the **Label** text field.
- 3 Locate the **Boundary Selection** section. Click  **Clear Selection**.
- 4 Select Boundaries 19–22 only.



Enclosed Cavity: Left Ventricle, Enclosed Cavity: Right Ventricle

- 1 In the **Model Builder** window, under **Component 1 (comp1) > Solid Mechanics (solid)**, Ctrl-click to select **Enclosed Cavity: Left Ventricle** and **Enclosed Cavity: Right Ventricle**.
- 2 Right-click and choose **Group**.

Internal Volumes

In the **Settings** window for **Group**, type Internal Volumes in the **Label** text field.

ADD STUDY

- 1 In the **Home** toolbar, click  **Add Study** to open the **Add Study** window.
- 2 Go to the **Add Study** window.
- 3 Find the **Physics interfaces in study** subsection. In the table, clear the **Solve** checkboxes for **Wall Distance: Epicardium (wd)**, **Wall Distance: Endocardium (wd2)**, and **Sheet Direction (cc)**.
- 4 Find the **Studies** subsection. In the **Select Study** tree, select **General Studies > Time Dependent**.
- 5 Click the **Add Study** button in the window toolbar.
- 6 In the **Home** toolbar, click  **Add Study** to close the **Add Study** window.

STUDY: EXCITATION-CONTRACTION

In the **Settings** window for **Study**, type Study: Excitation-Contraction in the **Label** text field.

Set up the solver and initialize the solution to generate the Fiber default plot.

Step 1: Time Dependent

- 1 In the **Model Builder** window, under **Study: Excitation-Contraction** click **Step 1: Time Dependent**.
- 2 In the **Settings** window for **Time Dependent**, locate the **Study Settings** section.
- 3 From the **Time unit** list, choose **ms**.
- 4 In the **Output times** text field, type range (0,5,320).
- 5 Click to expand the **Values of Dependent Variables** section. Find the **Values of variables not solved for** subsection. From the **Settings** list, choose **User controlled**.
- 6 From the **Method** list, choose **Solution**.
- 7 From the **Study** list, choose **Study: Fiber Direction, Stationary**.
- 8 In the **Study** toolbar, click  **Get Initial Value**.

RESULTS

Study: Excitation-Contraction/Solution 2 (sol2)



- 1 In the **Model Builder** window, expand the **Results > Datasets** node, then click **Study: Excitation-Contraction/Solution 2 (sol2)**.
- 2 In the **Settings** window for **Solution**, locate the **Solution** section.
- 3 From the **Frame** list, choose **Material (X, Y, Z)**.

*Active Stress (Sa), Electrophysiology: Conductance of Slow Processes (r),
Electrophysiology: Transmembrane Potential (Phi), Stress (solid)*

- 1 In the **Model Builder** window, under **Results**, Ctrl-click to select **Stress (solid)**, **Electrophysiology: Transmembrane Potential (Phi)**, **Electrophysiology: Conductance of Slow Processes (r)**, and **Active Stress (Sa)**.
Remove default plots that are not used.
- 2 Right-click and choose **Delete**.

Here the steps to obtain the model thumbnail are shown.

RESULT TEMPLATES

- 1 In the **Results** toolbar, click  **Result Templates** to open the **Result Templates** window.
- 2 Go to the **Result Templates** window.
- 3 In the tree, select **Study: Excitation-Contraction/Solution 2 (sol2) > Solid Mechanics > Fibers (solid) > Fiber, Hyperelastic Material I (solid)**.
- 4 Click the **Add Result Template** button in the window toolbar.
- 5 In the **Results** toolbar, click  **Result Templates** to close the **Result Templates** window.

RESULTS

Fiber

- 1 In the **Settings** window for **3D Plot Group**, type **Fiber** in the **Label** text field.
- 2 Click to expand the **Title** section. In the **Title** text area, type **Fiber orientation**.
- 3 In the **Fiber** toolbar, click  **Plot**.

Endocardium

- 1 In the **Model Builder** window, expand the **Fiber** node, then click **Fiber I**.
- 2 In the **Settings** window for **Streamline**, type **Endocardium** in the **Label** text field.
- 3 Locate the **Streamline Positioning** section. From the **Positioning** list, choose **On selected entities**.

- 4 From the **Point distribution** list, choose **Mesh based**.
- 5 In the **Element refinement** text field, type 2.
- 6 Locate the **Selection** section. Click to select the  **Activate Selection** toggle button.
- 7 Select Boundaries 1–3, 8, 9, 13, 14, and 17 only.
- 8 Locate the **Coloring and Style** section. Find the **Line style** subsection. From the **Type** list, choose **Line**.

Filter 1

Right-click **Endocardium** and choose **Filter**.

Color Expression

- 1 In the **Settings** window for **Color Expression**, locate the **Expression** section.
- 2 In the **Expression** text field, type theta.
- 3 In the **Unit** field, type deg.
- 4 Click to expand the **Range** section. Select the **Manual color range** checkbox.
- 5 In the **Minimum** text field, type -60.
- 6 In the **Maximum** text field, type 60.

Filter 1

- 1 In the **Model Builder** window, click **Filter 1**.
- 2 In the **Settings** window for **Filter**, locate the **Element Selection** section.
- 3 In the **Logical expression for inclusion** text field, type $\text{Beta} > 0.95$.

Myocardium

- 1 In the **Model Builder** window, right-click **Endocardium** and choose **Duplicate**.
- 2 In the **Settings** window for **Streamline**, type Myocardium in the **Label** text field.
- 3 Locate the **Selection** section. Click  **Clear Selection**.
- 4 Select Boundaries 2, 8, 13, and 14 only.
- 5 Locate the **Streamline Positioning** section. In the **Element refinement** text field, type 1.
- 6 Click to expand the **Inherit Style** section. From the **Plot** list, choose **Endocardium**.



Filter 1

- 1 In the **Model Builder** window, expand the **Myocardium** node, then click **Filter 1**.
- 2 In the **Settings** window for **Filter**, locate the **Element Selection** section.
- 3 In the **Logical expression for inclusion** text field, type $(\text{Beta} > 0.45) * (\text{Beta} < 0.55) * (Z < -cL/9)$.

Epicardium

- 1 In the **Model Builder** window, right-click **Myocardium** and choose **Duplicate**.
- 2 In the **Settings** window for **Streamline**, type Epicardium in the **Label** text field.
- 3 Locate the **Selection** section. Click  **Clear Selection**.
- 4 Select Boundaries 2, 3, 5, 8–11, 13–15, 17, and 18 only.
- 5 Locate the **Streamline Positioning** section. In the **Element refinement** text field, type 3.

Filter 1

- 1 In the **Model Builder** window, expand the **Epicardium** node, then click **Filter 1**.
- 2 In the **Settings** window for **Filter**, locate the **Element Selection** section.
- 3 In the **Logical expression for inclusion** text field, type $\text{Beta} < 0.05 * ((\text{sys4}.\text{phi} > -100[\text{deg}]) * (\text{sys4}.\text{phi} < 190[\text{deg}]) * (\text{Z} > -\text{cL}/3) \ || \ (\text{Z} < -\text{cL}/3))$.
- 4 In the **Fiber** toolbar, click  **Plot**.
- 5 Click the  **Show Grid** button in the **Graphics** toolbar.

Fiber



- 1 Click the  **Zoom Extents** button in the **Graphics** toolbar.
Create a 3D plot to display the active potential distribution while the simulation runs.

3D Plot Group 6

In the **Results** toolbar, click  **3D Plot Group**.

Set default units for result presentation.

Preferred Units 1

- 1 In the **Results** toolbar, click  **Configurations** and choose **Preferred Units**.
- 2 In the **Settings** window for **Preferred Units**, locate the **Units** section.
- 3 Click  **Add Physical Quantity**.
- 4 In the **Physical Quantity** dialog, type electricpotential in the text field.
- 5 In the tree, select **Electromagnetics > Electric potential (V)**.
- 6 Click **OK**.
- 7 In the **Settings** window for **Preferred Units**, locate the **Units** section.
- 8 In the table, enter the following settings:

Quantity	Unit	Preferred unit
Electric potential	V	mV

- 9 Click  **Apply**.

Potential

- 1 In the **Model Builder** window, under **Results** click **3D Plot Group 6**.
- 2 In the **Settings** window for **3D Plot Group**, type **Potential** in the **Label** text field.
- 3 Locate the **Data** section. From the **Dataset** list, choose **Study: Excitation-Contraction/Solution 2 (sol2)**.

Volume 1

- 1 Right-click **Potential** and choose **Volume**.
- 2 In the **Settings** window for **Volume**, locate the **Expression** section.
- 3 In the **Expression** text field, type Φ .
- 4 Click to expand the **Range** section. Select the **Manual color range** checkbox.
- 5 In the **Minimum** text field, type -80.
- 6 In the **Maximum** text field, type 20.

Deformation 1

- 1 Right-click **Volume 1** and choose **Deformation**.
- 2 In the **Settings** window for **Deformation**, locate the **Scale** section.
- 3 Select the **Scale factor** checkbox. In the associated text field, type 1.

STUDY: EXCITATION-CONTRACTION

- 1 In the **Model Builder** window, click **Study: Excitation-Contraction**.
- 2 In the **Settings** window for **Study**, locate the **Study Settings** section.
- 3 Clear the **Generate default plots** checkbox.

Step 1: Time Dependent



- 1 In the **Model Builder** window, under **Study: Excitation-Contraction** click **Step 1: Time Dependent**.
- 2 In the **Settings** window for **Time Dependent**, click to expand the **Results While Solving** section.
- 3 Select the **Plot** checkbox.
- 4 In the table, enter the following settings:

Plot group	Plot window
Potential	Graphics

- 5 In the **Study** toolbar, click  **Compute**.

RESULTS

Contraction, Snapshots

- 1 In the **Results** toolbar, click  **3D Plot Group**.
- 2 In the **Settings** window for **3D Plot Group**, type **Contraction, Snapshots** in the **Label** text field.
- 3 Locate the **Data** section. From the **Dataset** list, choose **Study: Excitation-Contraction/Solution 2 (sol2)**.
- 4 Locate the **Title** section. From the **Title type** list, choose **Manual**.
- 5 In the **Title** text area, type **Potential and deformation**.
- 6 Click to expand the **Plot Array** section. From the **Array type** list, choose **Square**.
- 7 From the **Array plane** list, choose **xz**.
- 8 Click the  **Go to XZ View** button in the **Graphics** toolbar.

Slice 1

- 1 Right-click **Contraction, Snapshots** and choose **Slice**.
- 2 In the **Settings** window for **Slice**, locate the **Data** section.
- 3 From the **Dataset** list, choose **Study: Excitation-Contraction/Solution 2 (sol2)**.
- 4 From the **Time (ms)** list, choose **5**.
- 5 Locate the **Expression** section. In the **Expression** text field, type **Phi**.
- 6 Locate the **Plane Data** section. From the **Plane** list, choose **ZX-planes**.
- 7 In the **Planes** text field, type **1**.
- 8 Click to expand the **Plot Array** section. Select the **Manual indexing** checkbox.

Deformation 1

- 1 Right-click **Slice 1** and choose **Deformation**.
- 2 In the **Settings** window for **Deformation**, locate the **Scale** section.
- 3 Select the **Scale factor** checkbox. In the associated text field, type **1**.
- 4 In the **Contraction, Snapshots** toolbar, click  **Plot**.

Slice 2

- 1 In the **Model Builder** window, under **Results > Contraction, Snapshots** right-click **Slice 1** and choose **Duplicate**.
- 2 In the **Settings** window for **Slice**, click to expand the **Title** section.
- 3 From the **Title type** list, choose **None**.
- 4 Locate the **Plane Data** section. From the **Plane** list, choose **XY-planes**.

- 5 In the **Planes** text field, type 1.
- 6 Locate the **Coloring and Style** section. Clear the **Color legend** checkbox.
- 7 Click to expand the **Inherit Style** section. From the **Plot** list, choose **Slice 1**.

Annotation 1

- 1 In the **Model Builder** window, right-click **Contraction, Snapshots** and choose **Annotation**.
- 2 In the **Settings** window for **Annotation**, locate the **Annotation** section.
- 3 In the **Text** text field, type $t=5$ ms.
- 4 Locate the **Position** section. In the **Z** text field, type 20.
- 5 Click to expand the **Plot Array** section. Select the **Manual indexing** checkbox.

Annotation 1, Slice 1, Slice 2

- 1 In the **Model Builder** window, under **Results > Contraction, Snapshots**, Ctrl-click to select **Slice 1**, **Slice 2**, and **Annotation 1**.
- 2 Right-click and choose **Duplicate**.

Slice 3

- 1 In the **Settings** window for **Slice**, locate the **Title** section.
- 2 From the **Title type** list, choose **None**.
- 3 Locate the **Coloring and Style** section. Clear the **Color legend** checkbox.
- 4 Locate the **Inherit Style** section. From the **Plot** list, choose **Slice 1**.
- 5 Locate the **Data** section. From the **Time (ms)** list, choose **35**.
- 6 Locate the **Plot Array** section. In the **Column index** text field, type 1.

Slice 4

- 1 In the **Model Builder** window, click **Slice 4**.
- 2 In the **Settings** window for **Slice**, locate the **Data** section.
- 3 From the **Time (ms)** list, choose **35**.
- 4 Locate the **Plot Array** section. In the **Column index** text field, type 1.

Annotation 2

- 1 In the **Model Builder** window, click **Annotation 2**.
- 2 In the **Settings** window for **Annotation**, locate the **Annotation** section.
- 3 In the **Text** text field, type $t=35$ ms.
- 4 Locate the **Plot Array** section. In the **Column index** text field, type 1.
- 5 In the **Contraction, Snapshots** toolbar, click  **Plot**.

6 Click the  **Zoom Extents** button in the **Graphics** toolbar.

Annotation 2, Slice 3, Slice 4

- 1 In the **Model Builder** window, under **Results > Contraction, Snapshots**, Ctrl-click to select **Slice 3, Slice 4**, and **Annotation 2**.
- 2 Right-click and choose **Duplicate**.



Slice 5

- 1 In the **Settings** window for **Slice**, locate the **Data** section.
- 2 From the **Time (ms)** list, choose **55**.
- 3 Locate the **Plot Array** section. In the **Column index** text field, type 2.

Slice 6

- 1 In the **Model Builder** window, click **Slice 6**.
- 2 In the **Settings** window for **Slice**, locate the **Data** section.
- 3 From the **Time (ms)** list, choose **55**.
- 4 Locate the **Plot Array** section. In the **Column index** text field, type 2.

Annotation 3

- 1 In the **Model Builder** window, click **Annotation 3**.
- 2 In the **Settings** window for **Annotation**, locate the **Annotation** section.
- 3 In the **Text** text field, type $t=50$ ms.
- 4 Locate the **Plot Array** section. In the **Column index** text field, type 2.
- 5 In the **Contraction, Snapshots** toolbar, click  **Plot**.
- 6 Click the  **Zoom Extents** button in the **Graphics** toolbar.

Annotation 3, Slice 5, Slice 6

- 1 In the **Model Builder** window, under **Results > Contraction, Snapshots**, Ctrl-click to select **Slice 5, Slice 6**, and **Annotation 3**.
- 2 Right-click and choose **Duplicate**.

Slice 7



- 1 In the **Settings** window for **Slice**, locate the **Data** section.
- 2 From the **Time (ms)** list, choose **100**.
- 3 Locate the **Plot Array** section. In the **Column index** text field, type 3.

Slice 8

- 1 In the **Model Builder** window, click **Slice 8**.

- 2 In the **Settings** window for **Slice**, locate the **Data** section.
- 3 From the **Time (ms)** list, choose **100**.
- 4 Locate the **Plot Array** section. In the **Column index** text field, type 3.

Annotation 4

- 1 In the **Model Builder** window, click **Annotation 4**.
- 2 In the **Settings** window for **Annotation**, locate the **Annotation** section.
- 3 In the **Text** text field, type $t=100$ ms.
- 4 Locate the **Plot Array** section. In the **Column index** text field, type 3.
- 5 In the **Contraction, Snapshots** toolbar, click  **Plot**.
- 6 Click the  **Zoom Extents** button in the **Graphics** toolbar.

Annotation 4, Slice 7, Slice 8

- 1 In the **Model Builder** window, under **Results > Contraction, Snapshots**, Ctrl-click to select **Slice 7, Slice 8**, and **Annotation 4**.
- 2 Right-click and choose **Duplicate**.

Slice 9



- 1 In the **Settings** window for **Slice**, locate the **Data** section.
- 2 From the **Time (ms)** list, choose **145**.
- 3 Locate the **Plot Array** section. In the **Row index** text field, type -1.
- 4 In the **Column index** text field, type 0.

Slice 10

- 1 In the **Model Builder** window, click **Slice 10**.
- 2 In the **Settings** window for **Slice**, locate the **Data** section.
- 3 From the **Time (ms)** list, choose **145**.
- 4 Locate the **Plot Array** section. In the **Row index** text field, type -1.
- 5 In the **Column index** text field, type 0.

Annotation 5

- 1 In the **Model Builder** window, click **Annotation 5**.
- 2 In the **Settings** window for **Annotation**, locate the **Annotation** section.
- 3 In the **Text** text field, type $t=145$ ms.
- 4 Locate the **Position** section. In the **Z** text field, type -80.
- 5 Locate the **Plot Array** section. In the **Row index** text field, type -1.

- 6 In the **Column index** text field, type 0.
- 7 In the **Contraction, Snapshots** toolbar, click  **Plot**.
- 8 Click the  **Zoom Extents** button in the **Graphics** toolbar.

Annotation 5, Slice 10, Slice 9

- 1 In the **Model Builder** window, under **Results** > **Contraction, Snapshots**, Ctrl-click to select **Slice 9, Slice 10**, and **Annotation 5**.
- 2 Right-click and choose **Duplicate**.



Slice 11

- 1 In the **Settings** window for **Slice**, locate the **Data** section.
- 2 From the **Time (ms)** list, choose **200**.
- 3 Locate the **Plot Array** section. In the **Column index** text field, type 1.

Slice 12

- 1 In the **Model Builder** window, click **Slice 12**.
- 2 In the **Settings** window for **Slice**, locate the **Data** section.
- 3 From the **Time (ms)** list, choose **200**.
- 4 Locate the **Plot Array** section. In the **Column index** text field, type 1.

Annotation 6

- 1 In the **Model Builder** window, click **Annotation 6**.
- 2 In the **Settings** window for **Annotation**, locate the **Annotation** section.
- 3 In the **Text** text field, type $t=200$ ms.
- 4 Locate the **Plot Array** section. In the **Column index** text field, type 1.
- 5 In the **Contraction, Snapshots** toolbar, click  **Plot**.
- 6 Click the  **Zoom Extents** button in the **Graphics** toolbar.

Annotation 6, Slice 11, Slice 12

- 1 In the **Model Builder** window, under **Results** > **Contraction, Snapshots**, Ctrl-click to select **Slice 11, Slice 12**, and **Annotation 6**.
- 2 Right-click and choose **Duplicate**.



Annotation 7, Slice 13, Slice 14

- 1 In the **Settings** window for **Slice**, locate the **Data** section.
- 2 From the **Time (ms)** list, choose **250**.
- 3 Locate the **Plot Array** section. In the **Column index** text field, type 2.

Slice 14

- 1 In the **Model Builder** window, click **Slice 14**.
- 2 In the **Settings** window for **Slice**, locate the **Data** section.
- 3 From the **Time (ms)** list, choose **250**.
- 4 Locate the **Plot Array** section. In the **Column index** text field, type 2.

Annotation 7

- 1 In the **Model Builder** window, click **Annotation 7**.
- 2 In the **Settings** window for **Annotation**, locate the **Plot Array** section.
- 3 In the **Column index** text field, type 2.
- 4 Locate the **Annotation** section. In the **Text** text field, type $t=250$ ms.
- 5 In the **Contraction, Snapshots** toolbar, click  **Plot**.
- 6 Click the  **Zoom Extents** button in the **Graphics** toolbar.

Annotation 7, Slice 13, Slice 14

- 1 In the **Model Builder** window, under **Results > Contraction, Snapshots**, Ctrl-click to select **Slice 13, Slice 14, and Annotation 7**.
- 2 Right-click and choose **Duplicate**.

Slice 15

- 1 In the **Settings** window for **Slice**, locate the **Data** section.
- 2 From the **Time (ms)** list, choose **300**.
- 3 Locate the **Plot Array** section. In the **Column index** text field, type 3.

Slice 16

- 1 In the **Model Builder** window, click **Slice 16**.
- 2 In the **Settings** window for **Slice**, locate the **Data** section.
- 3 From the **Time (ms)** list, choose **300**.
- 4 Locate the **Plot Array** section. In the **Column index** text field, type 3.



Annotation 8

- 1 In the **Model Builder** window, click **Annotation 8**.
- 2 In the **Settings** window for **Annotation**, locate the **Annotation** section.
- 3 In the **Text** text field, type $t=300$ ms.
- 4 Locate the **Plot Array** section. In the **Column index** text field, type 3.

Slice 2

Click the  **Zoom Extents** button in the **Graphics** toolbar.

Contraction, Snapshots

- 1 Click the  **Transparency** button in the **Graphics** toolbar.
- 2 Click the  **Orthographic Projection** button in the **Graphics** toolbar.
- 3 In the **Model Builder** window, click **Contraction, Snapshots**.
- 4 In the **Contraction, Snapshots** toolbar, click  **Plot**.

Volume Change

- 1 In the **Results** toolbar, click  **ID Plot Group**.
- 2 In the **Settings** window for **ID Plot Group**, type Volume Change in the **Label** text field.
- 3 Locate the **Data** section. From the **Dataset** list, choose **Study: Excitation-Contraction/ Solution 2 (sol2)**.
- 4 Locate the **Plot Settings** section. Select the **y-axis label** checkbox.
- 5 Click to expand the **Title** section. From the **Title type** list, choose **None**.
- 6 Locate the **Plot Settings** section. In the **y-axis label** text field, type Current volume (ml).
- 7 Locate the **Legend** section. From the **Position** list, choose **Upper middle**.

Global 1

- 1 Right-click **Volume Change** and choose **Global**.
- 2 In the **Settings** window for **Global**, locate the **y-Axis Data** section.
- 3 In the table, enter the following settings:

Expression	Unit	Description
solid.enc1.V	ml	Total volume, deformed configuration
solid.enc2.V	ml	Total volume, deformed configuration

- 4 Click to expand the **Legends** section. From the **Legends** list, choose **Manual**.
- 5 In the table, enter the following settings:

Legends
Left ventricular chamber
Right ventricular chamber

- 6 In the **Volume Change** toolbar, click  **Plot**.

Point at Z=-1mm

- 1 In the **Results** toolbar, click  **Cut Point 3D**.
- 2 In the **Settings** window for **Cut Point 3D**, type **Point at Z=-1mm** in the **Label** text field.
- 3 Locate the **Data** section. From the **Dataset** list, choose **Study: Excitation-Contraction/ Solution 2 (sol2)**.
- 4 Locate the **Point Data** section. In the **X** text field, type **25**.
- 5 In the **Y** text field, type **0**.
- 6 In the **Z** text field, type **-1**.

Point at Z=-40mm

- 1 Right-click **Point at Z=-1mm** and choose **Duplicate**.
- 2 In the **Settings** window for **Cut Point 3D**, type **Point at Z=-40mm** in the **Label** text field.
- 3 Locate the **Point Data** section. In the **X** text field, type **20**.
- 4 In the **Z** text field, type **-40**.

Point at Z=-60mm

- 1 Right-click **Point at Z=-40mm** and choose **Duplicate**.
- 2 In the **Settings** window for **Cut Point 3D**, type **Point at Z=-60mm** in the **Label** text field.
- 3 Locate the **Point Data** section. In the **X** text field, type **0**.
- 4 In the **Z** text field, type **-60**.

Activation Time

- 1 In the **Results** toolbar, click  **ID Plot Group**.
- 2 In the **Settings** window for **ID Plot Group**, type **Activation Time** in the **Label** text field.
- 3 Locate the **Title** section. From the **Title type** list, choose **None**.

Point Graph 1

- 1 Right-click **Activation Time** and choose **Point Graph**.
- 2 In the **Settings** window for **Point Graph**, locate the **Data** section.
- 3 From the **Dataset** list, choose **Point at Z=-1mm**.
- 4 Locate the **y-Axis Data** section. In the **Expression** text field, type **Phi**.
- 5 Click to expand the **Legends** section. Select the **Show legends** checkbox.
- 6 From the **Legends** list, choose **Manual**.

7 In the table, enter the following settings:

Legends

Point at Z=-1 mm

Point Graph 2

- 1 Right-click **Point Graph 1** and choose **Duplicate**.
- 2 In the **Settings** window for **Point Graph**, locate the **Data** section.
- 3 From the **Dataset** list, choose **Point at Z=-40mm**.
- 4 Click to expand the **Title** section. From the **Title type** list, choose **None**.
- 5 Locate the **Legends** section. In the table, enter the following settings:

Legends

Point at Z=-40 mm

Point Graph 3



- 1 Right-click **Point Graph 2** and choose **Duplicate**.
- 2 In the **Settings** window for **Point Graph**, locate the **Data** section.
- 3 From the **Dataset** list, choose **Point at Z=-60mm**.
- 4 Locate the **Legends** section. In the table, enter the following settings:

Legends

Point at Z=-60 mm

- 5 In the **Activation Time** toolbar, click  **Plot**.

Heart Deformation

- 1 In the **Results** toolbar, click  **Animation** and choose **Player**.
Create an animation to see the excitation path.
- 2 In the **Settings** window for **Animation**, type Heart Deformation in the **Label** text field.
- 3 Locate the **Scene** section. From the **Subject** list, choose **Potential**.
- 4 Locate the **Frames** section. In the **Number of frames** text field, type 50.
- 5 Click the  **Zoom Extents** button in the **Graphics** toolbar.



Appendix — Geometry Modeling Instructions

From the **File** menu, choose **New**.

NEW

In the **New** window, click  **Model Wizard**.

MODEL WIZARD

- 1 In the **Model Wizard** window, click .
- 2 Click  **Done**.

GLOBAL DEFINITIONS

Heart Geometry Parameters

- 1 In the **Model Builder** window, under **Global Definitions** click **Parameters I**.
- 2 In the **Settings** window for **Parameters**, type Heart Geometry Parameters in the **Label** text field.
- 3 Locate the **Parameters** section. Click  **Load from File**.
- 4 Browse to the model's Application Libraries folder and double-click the file `biventricular_cardiac_model_geom_parameters.txt`.

GEOMETRY I

- 1 In the **Model Builder** window, under **Component I (comp1)** click **Geometry I**.
- 2 In the **Settings** window for **Geometry**, locate the **Units** section.
- 3 From the **Length unit** list, choose **mm**.

Ellipsoid: Left Ventricle

- 1 In the **Geometry** toolbar, click  **More Primitives** and choose **Ellipsoid**.
- 2 In the **Settings** window for **Ellipsoid**, type Ellipsoid: Left Ventricle in the **Label** text field.
- 3 Locate the **Size and Shape** section. In the **a-semiaxis** text field, type aL.
- 4 In the **b-semiaxis** text field, type bL.
- 5 In the **c-semiaxis** text field, type cL.
- 6 Click to expand the **Layers** section. In the table, enter the following settings:

Layer name	Thickness (mm)
Layer 1	tL



Ellipsoid: Right Ventricle

- 1 Right-click **Ellipsoid: Left Ventricle** and choose **Duplicate**.



- 2 In the **Settings** window for **Ellipsoid**, type Ellipsoid: Right Ventricle in the **Label** text field.
- 3 Locate the **Size and Shape** section. In the **a-semiaxis** text field, type aR.
- 4 In the **b-semiaxis** text field, type bR.
- 5 In the **c-semiaxis** text field, type cR.
- 6 Locate the **Layers** section. In the table, enter the following settings:

Layer name	Thickness (mm)
Layer 1	tR

Partition Domains 1 (pard1)

- 1 In the **Geometry** toolbar, click  **Booleans and Partitions** and choose **Partition Domains**.
- 2 Click the  **Transparency** button in the **Graphics** toolbar.
- 3 On the object **elp2**, select Domains 1, 3, 5, 6, and 8 only.
- 4 In the **Settings** window for **Partition Domains**, locate the **Partition Domains** section.
- 5 From the **Partition with** list, choose **Faces**.
- 6 On the object **elp1**, select Boundaries 16 and 22 only.

Delete Entities 1 (dell)

- 1 In the **Geometry** toolbar, click  **Delete**.
- 2 In the **Settings** window for **Delete Entities**, locate the **Entities or Objects to Delete** section.
- 3 From the **Geometric entity level** list, choose **Domain**.
- 4 On the object **elp1**, select Domains 2, 4, 5, 7, and 9 only.
- 5 On the object **pard1**, select Domains 1–7, 9, and 10 only.
- 6 Click  **Build All Objects**.

7 Click the  **Zoom Extents** button in the **Graphics** toolbar.

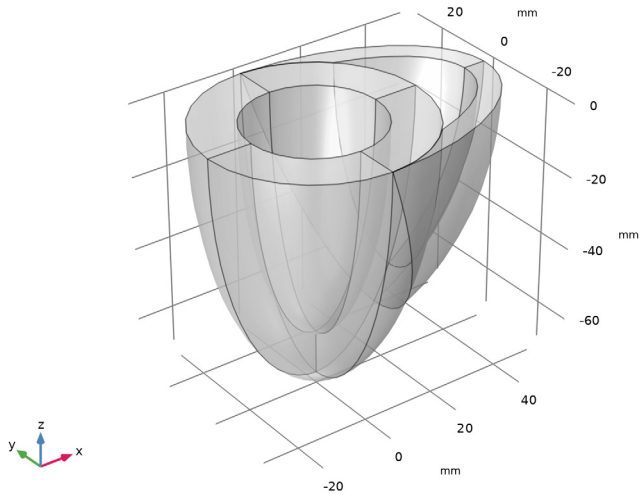

Use virtual operations to ignore faces and edges to simplify the geometry and avoid unnecessary mesh refinement zones.

Ignore Faces 1 (igf1)

- 1 In the **Geometry** toolbar, click  **Virtual Operations** and choose **Ignore Faces**.
- 2 On the object **fin**, select Boundaries 11 and 20 only.

3 In the **Geometry** toolbar, click  **Build All**.

