



Model created in COMSOL Multiphysics 6.4

# Inflation of a Spherical Rubber Balloon

## Introduction

---

This example demonstrates the inflation of a rubber balloon using different hyperelastic material models and compares the results with analytical expressions.

Controlled inflation is of importance in clinical applications, cardiovascular research, and medical device industry (Ref. 2), among others. This example demonstrates such controlled inflation of a balloon based on radial stretch.

The example is taken from the book *Nonlinear Solid Mechanics* by G. A. Holzapfel (Ref. 1).

## Model Definition

---

This example compares the hoop stress and inflation pressure as a function of the stretch for a spherical rubber balloon, the geometry of which is depicted in Figure 1.

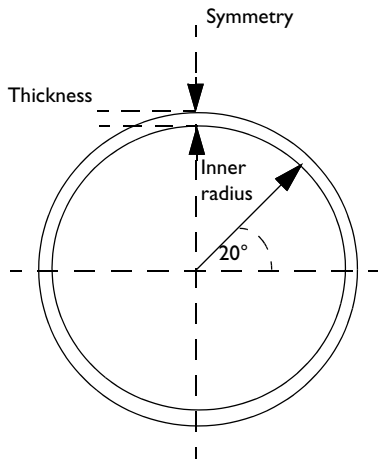

*Figure 1: Model geometry. The initial inner radius is set to 10 cm and the initial thickness to 1 mm.*

In this example, the following four hyperelastic material models are compared: neo-Hookean, Mooney–Rivlin, Ogden, and Varga.

Due to the spherical symmetry, an arbitrary sector in the azimuthal direction can be used. Here, a 20 degree sector is modeled in a 2D axial symmetry plane, see Figure 2.

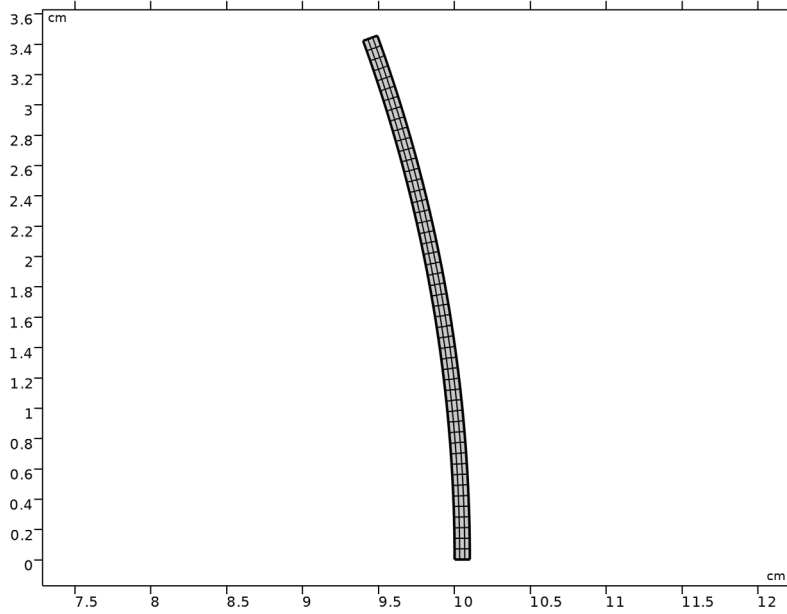

Figure 2: 2D axisymmetric geometry and mesh.

## Results and Discussion

The results are compared with the analytical expression for a thin-walled vessel. The inflation pressure is a function of the hoop stress  $\sigma_\theta$ , the current inner radius  $r$ , and the current thickness  $h$

$$p_i = 2\frac{h}{r}\sigma_\theta$$

For spherical balloons, the hoop stress  $\sigma_\theta$  is equal to the largest principal stresses,  $\sigma_1$  and  $\sigma_2$ . These two principal stretches are in the plane tangential to the sphere and are equal,  $\lambda = \lambda_1 = \lambda_2 = r/R$ , which is typical for equibiaxial deformation. Here,  $r$  and  $R$  are the current and initial inner radii, respectively.

Due to the incompressibility assumption, the third principal stretch (this is the stretch in the radial direction) is equal to  $\lambda_3 = 1/\lambda^2 = h/H$ , where  $h$  and  $H$  are the current and initial balloon thickness, respectively.

The analytical expression for the hoop stress for the Ogden material model becomes (Ref. 1)

$$\sigma_{\theta} = \sum_{p=1}^N \mu_p (\lambda^{\alpha_p} - \lambda^{-2\alpha_p})$$

where  $\alpha_p$  and  $\mu_p$  are Ogden parameters, and  $\lambda$  is the in-plane principal stretch.

Because  $r = R\lambda$  and  $h = H/\lambda^2$ , the analytical expression for the inflation pressure can be written as a function of the Ogden parameters, the stretch, and the initial thickness and radius of the balloon as

$$p_i = 2\frac{h}{r}\sigma_{\theta} = 2\frac{H}{R}\sum_{p=1}^N \mu_p (\lambda^{\alpha_p-3} - \lambda^{-2\alpha_p-3})$$

Balloons typically show a stiff initial response, after which the internal pressure reaches a local maximum and the balloon snaps through, see [Figure 3](#). At larger stretches, a local minimum in pressure occurs and the sign of the stiffness changes back to positive. These local maxima and minima are called limit points. Some material models, like Mooney–Rivlin and Ogden, can exhibit more than one limit point. In contrast, the neo-Hookean and Varga material models can only reproduce balloon inflations at small levels of extension.

The computed inflation pressure and hoop stress as functions of the applied stretch are shown in [Figure 3](#) and [Figure 4](#), respectively. Both figures include the computed results for four different material models, and they are in excellent agreement with the results described in [Ref. 1](#), page 241.

[Figure 5](#) shows the distribution of the hoop stress for a neo-Hookean material at the final step of the solution.

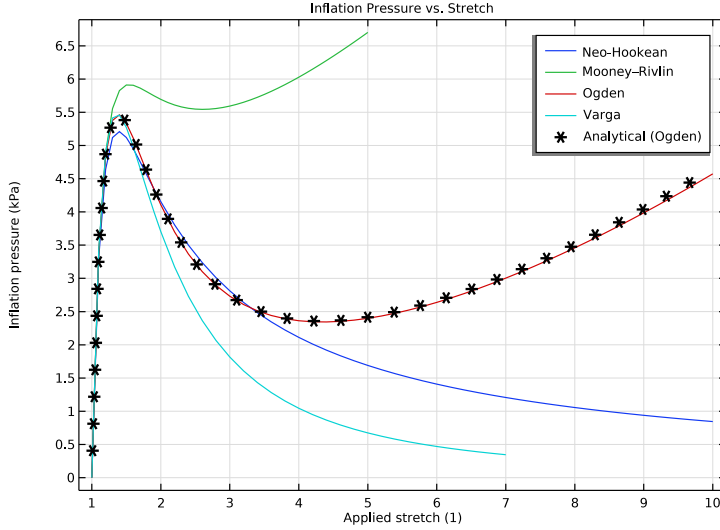

Figure 3: Computed inflation pressure as a function of circumferential stretch for different material models, compared with the analytical expression for the Ogden material model.

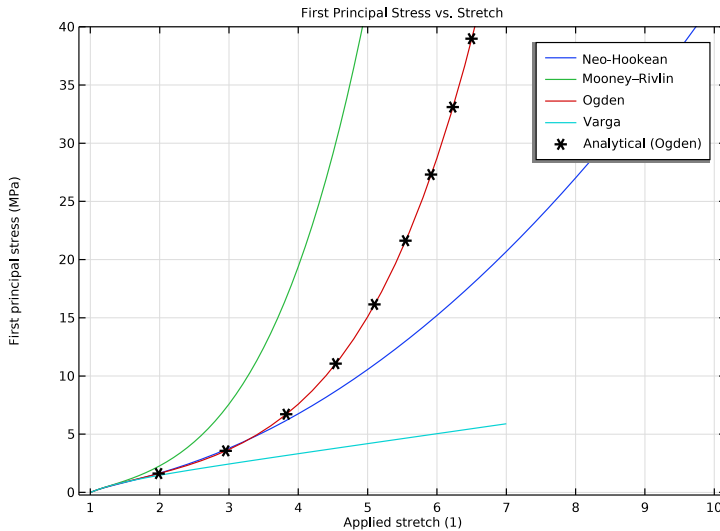

Figure 4: Computed hoop stress as a function of circumferential stretch for different material models, compared with the analytical expression for the Ogden material model.

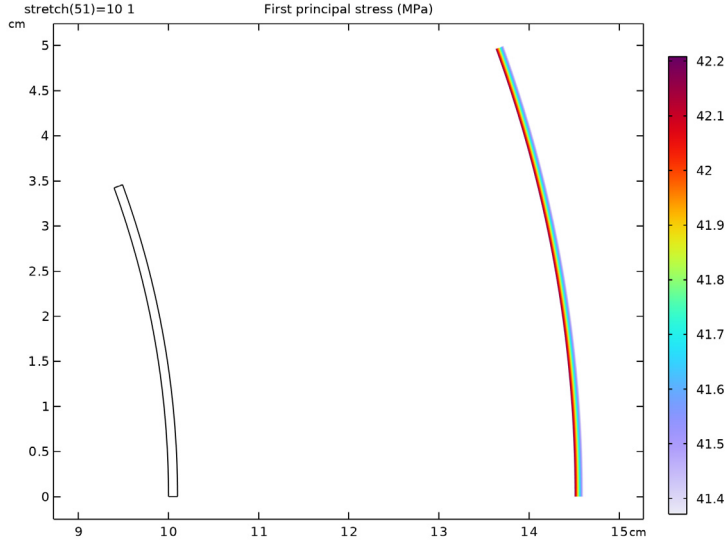

Figure 5: Distribution of hoop stress on the 2D axisymmetric cross section modeled with a neo-Hookean material at maximum inflation. Note that a scaling factor has been used in order to visualize the stress distribution across the thickness in the deformed configuration.

### Notes About the COMSOL Implementation

Hyperelastic material models are constructed by specifying the corresponding elastic strain energy density expressions. The *Nonlinear Structural Materials Module* provides several predefined material models together with an option to enter user-defined expressions for the strain energy density.

The predefined nearly incompressible version of the neo-Hookean material with quadratic volumetric strain energy formulation uses the isochoric invariant  $\bar{I}_1 = \text{tr}(\bar{C}_{e1})$  and the elastic volume ratio  $J_{e1} = \sqrt{\det(C_{e1})}$  according to

$$W_s = \frac{1}{2}\mu(\bar{I}_1 - 3) + \frac{1}{2}\kappa(J_{e1} - 1)^2$$

In this example,  $\mu = 422.5$  kPa and  $\kappa = 10^5\mu$ . The Lamé parameters  $\mu$  and  $\kappa$  can be seen as representing the small strain shear and bulk modulus, respectively.

The predefined nearly incompressible Mooney–Rivlin material with quadratic volumetric strain energy formulation has an elastic strain energy density written in terms of the first

and second invariants of the isochoric elastic right Cauchy–Green deformation tensor,  $\bar{I}_1$  and  $\bar{I}_2$ , and the elastic volume ratio  $J_{el}$ :

$$W_s = C_{10}(\bar{I}_1 - 3) + C_{01}(\bar{I}_2 - 3) + \frac{1}{2}\kappa(J_{el} - 1)^2$$

The material parameters  $C_{10}$  and  $C_{01}$  are related to the shear modulus  $\mu = 2(C_{10} + C_{01})$ . In this example, they are set as  $C_{10} = 7/16\mu$  and  $C_{01} = \mu/16$ , so that the relation  $C_{10} = 7C_{01}$  is fulfilled.

In contrast to the invariant-based models, the predefined nearly incompressible Ogden material with quadratic volumetric strain energy formulation uses the isochoric elastic principal stretches and the elastic volume ratio  $J_{el}$ :

$$W_s = \sum_{p=1}^N \frac{\mu_p}{\alpha_p} (\bar{\lambda}_{el1}^{-\alpha_p} + \bar{\lambda}_{el2}^{-\alpha_p} + \bar{\lambda}_{el3}^{-\alpha_p} - 3) + \frac{1}{2}\kappa(J_{el} - 1)^2$$

Here,  $N = 3$  terms are used with the Ogden parameters provided in [Table 1](#).

TABLE 1: OGDEN PARAMETERS.

p	$\alpha_p$	$\mu_p$ (kPa)
1	1.3	630
2	5.0	1.2
3	-2.0	-10

The predefined nearly incompressible Varga strain energy density function is given as

$$W_s = c_1(\bar{\lambda}_{el1} + \bar{\lambda}_{el2} + \bar{\lambda}_{el3} - 3) + c_2(\bar{\lambda}_{el1}\bar{\lambda}_{el2} + \bar{\lambda}_{el2}\bar{\lambda}_{el3} + \bar{\lambda}_{el1}\bar{\lambda}_{el3} - 3) + \frac{1}{2}\kappa(J_{el} - 1)^2$$

Following the example in [Ref. 1](#), the material parameters are  $c_1 = 2\mu$  and  $c_2 = 0$ .

When the relation between the applied load and the displacement is nonunique (as in the snap-through during balloon inflation), a suitable modeling technique is to use an algebraic equation that controls the applied pressure, so that the model reaches the desired displacement increments. In this example, a **Global Equation** uses the radial displacement at point 3 to add an extra degree of freedom for the inflation pressure.

Global equations are a convenient way of adding an additional equation to a model. A global equation can be used to describe a load, constraint, material property, or anything else in the model that has a uniquely definable solution. In this example, the model is

augmented by a global equation that solves for the inflation pressure required to achieve a desired applied stretch.

## References

---

1. G.A. Holzapfel, *Nonlinear Solid Mechanics: A Continuum Approach for Engineering*, John Wiley & Sons, 2000.
2. H. Azarnoush, S. Vergnole, B. Boulet, R. DiRaddo, and G. Lamouche, “Real-time control of angioplasty balloon inflation based on feedback from intravascular optical coherence tomography: preliminary study on an artery phantom,” *IEEE Trans Biomed Eng.* vol. 59, pp. 697–705, 2012.

---

**Application Library path:** Nonlinear\_Structural\_Materials\_Module/  
Hyperelasticity/balloon\_inflation

---

## Modeling Instructions



---

From the **File** menu, choose **New**.

### NEW

In the **New** window, click  **Model Wizard**.

### MODEL WIZARD

- 1 In the **Model Wizard** window, click  **2D Axisymmetric**.
- 2 In the **Select Physics** tree, select **Structural Mechanics > Solid Mechanics (solid)**.
- 3 Click **Add**.
- 4 Click  **Study**.
- 5 In the **Select Study** tree, select **General Studies > Stationary**.
- 6 Click  **Done**.

### GLOBAL DEFINITIONS

Begin by defining all model parameters.

#### Parameters 1

- 1 In the **Model Builder** window, under **Global Definitions** click **Parameters 1**.

2 In the **Settings** window for **Parameters**, locate the **Parameters** section.

3 In the table, enter the following settings:

Name	Expression	Value	Description
Ri	10[cm]	0.1 m	Inner radius
H	1[mm]	0.001 m	Thickness
mu	4.225e5[Pa]	4.225E5 Pa	Shear modulus
kappa	1e5*mu	4.225E10 Pa	Bulk modulus
stretch	1[1]	1	Applied stretch
C10	0.4375*mu	1.8484E5 Pa	Mooney-Rivlin parameter C10
C01	0.0625*mu	26406 Pa	Mooney-Rivlin parameter C01
mu1	6.3e5[Pa]	6.3E5 Pa	Ogden parameter mu1
mu2	0.012e5[Pa]	1200 Pa	Ogden parameter mu2
mu3	-0.1e5[Pa]	-10000 Pa	Ogden parameter mu3
alpha1	1.3	1.3	Ogden parameter alpha1
alpha2	5	5	Ogden parameter alpha2
alpha3	-2	-2	Ogden parameter alpha3

Setting the bulk modulus to  $10^5$  times the shear modulus is based on the assumption that the material is incompressible.

## DEFINITIONS

### Variables 1

1 In the **Definitions** toolbar, click  **Local Variables**.

2 In the **Settings** window for **Variables**, locate the **Variables** section.

3 In the table, enter the following settings:

Name	Expression	Unit	Description
u_appl	(stretch-1)*Ri	m	Applied displacement

Use the applied stretch and the inner radius of the balloon to compute the applied displacement.

## GEOMETRY 1

Due to symmetry, it suffices to model a 20-degree sector of the balloon.

1 In the **Model Builder** window, under **Component 1 (comp1)** click **Geometry 1**.

- 2 In the **Settings** window for **Geometry**, locate the **Units** section.
- 3 From the **Length unit** list, choose **cm**.

#### *Circle 1 (c1)*

- 1 In the **Geometry** toolbar, click  **Circle**.
- 2 In the **Settings** window for **Circle**, locate the **Size and Shape** section.
- 3 In the **Radius** text field, type  $R_i+H$ .
- 4 In the **Sector angle** text field, type 20.
- 5 Click to expand the **Layers** section. In the table, enter the following settings:

Layer name	Thickness (cm)
Layer 1	H

- 6 Click  **Build All Objects**.

#### *Delete Entities 1 (dell)*

- 1 In the **Model Builder** window, right-click **Geometry 1** and choose **Delete Entities**.
- 2 In the **Settings** window for **Delete Entities**, locate the **Entities or Objects to Delete** section.
- 3 From the **Geometric entity level** list, choose **Domain**.
- 4 On the object **c1**, select Domain 1 only.
- 5 Click  **Build All Objects**.

### **SOLID MECHANICS (SOLID)**

Add the four **Hyperelastic Material** models to be studied.

#### *Neo-Hookean*

- 1 In the **Physics** toolbar, click  **Domains** and choose **Hyperelastic Material**.
- 2 In the **Settings** window for **Hyperelastic Material**, type Neo-Hookean in the **Label** text field.
- 3 Locate the **Domain Selection** section. From the **Selection** list, choose **All domains**.
- 4 Locate the **Hyperelastic Material** section. From the **Compressibility** list, choose **Nearly incompressible**.
- 5 In the  $\kappa$  text field, type kappa.
- 6 From the  $\mu$  list, choose **User defined**. In the associated text field, type mu.

#### *Mooney–Rivlin*

- 1 In the **Physics** toolbar, click  **Domains** and choose **Hyperelastic Material**.

- 2 In the **Settings** window for **Hyperelastic Material**, type Mooney-Rivlin in the **Label** text field.
- 3 Locate the **Domain Selection** section. From the **Selection** list, choose **All domains**.
- 4 Locate the **Hyperelastic Material** section. From the **Material model** list, choose **Mooney-Rivlin, two parameters**.
- 5 From the  $C_{10}$  list, choose **User defined**. In the associated text field, type C10.
- 6 From the  $C_{01}$  list, choose **User defined**. In the associated text field, type C01.
- 7 In the  $\kappa$  text field, type kappa.

#### Ogden

- 1 In the **Physics** toolbar, click  **Domains** and choose **Hyperelastic Material**.
- 2 In the **Settings** window for **Hyperelastic Material**, type Ogden in the **Label** text field.
- 3 Locate the **Domain Selection** section. From the **Selection** list, choose **All domains**.
- 4 Locate the **Hyperelastic Material** section. From the **Material model** list, choose **Ogden**.
- 5 Click **Add** twice.
- 6 In the **Ogden parameters** table, enter the following settings:

p	Shear modulus (Pa)	Alpha parameter (l)
1	mu1	alpha1
2	mu2	alpha2
3	mu3	alpha3

- 7 In the  $\kappa$  text field, type kappa.

#### Varga

- 1 In the **Physics** toolbar, click  **Domains** and choose **Hyperelastic Material**.
- 2 In the **Settings** window for **Hyperelastic Material**, type Varga in the **Label** text field.
- 3 Locate the **Domain Selection** section. From the **Selection** list, choose **All domains**.
- 4 Locate the **Hyperelastic Material** section. From the **Material model** list, choose **Varga**.
- 5 From the  $c_1$  list, choose **User defined**. In the associated text field, type  $2*\mu$ .
- 6 From the  $c_2$  list, choose **User defined**. In the  $\kappa$  text field, type kappa.

To enforce a symmetry constraint, add a **Roller** node.

#### Roller 1

- 1 In the **Physics** toolbar, click  **Boundaries** and choose **Roller**.
- 2 Select Boundaries 1 and 2 only.

Control the inflation of the balloon by the pressure.

#### *Boundary Load 1*

- 1 In the **Physics** toolbar, click  **Boundaries** and choose **Boundary Load**.
- 2 Select Boundary 3 only.
- 3 In the **Settings** window for **Boundary Load**, locate the **Force** section.
- 4 From the **Load type** list, choose **Pressure**.
- 5 In the  $p$  text field, type  $p\_f$ .

You will define the pressure  $p\_f$  using a **Global Equation** feature shortly. First, define a nonlocal integration coupling to evaluate the displacement at point 3.

### DEFINITIONS

#### *Integration 1 (intop1)*

- 1 In the **Definitions** toolbar, click  **Nonlocal Couplings** and choose **Integration**.
- 2 In the **Settings** window for **Integration**, locate the **Source Selection** section.
- 3 From the **Geometric entity level** list, choose **Point**.
- 4 Select Point 3 only.
- 5 Locate the **Advanced** section. From the **Frame** list, choose **Material (R, PHI, Z)**.
- 6 Clear the **Compute integral in revolved geometry** checkbox.

#### *Variables 1*

- 1 In the **Model Builder** window, click **Variables 1**.
- 2 In the **Settings** window for **Variables**, locate the **Variables** section.
- 3 In the table, enter the following settings:

Name	Expression	Unit	Description
ub	intop1(u)	m	Radial displacement, inner boundary



### SOLID MECHANICS (SOLID)

- 1 Click the  **Show More Options** button in the **Model Builder** toolbar.
- 2 In the **Show More Options** dialog, in the tree, select the checkbox for the node **Physics > Equation Contributions**.
- 3 Click **OK** enable global equations and other advanced modeling features to the **Solid Mechanics** interface.

### Global Equations I (ODEI)

- 1 In the **Physics** toolbar, click  **Global** and choose **Global Equations**.
- 2 In the **Settings** window for **Global Equations**, locate the **Global Equations** section.
- 3 In the table, enter the following settings:

Name	$f(u, ut, utt, t)$ (I)	Initial value (u_0) (I)	Initial value (ut_0) (I/s)	Description
p_f	ub-u_app1	0	0	

- 4 Locate the **Units** section. Click  **Select Dependent Variable Quantity**.
- 5 In the **Physical Quantity** dialog, type pressure in the text field.
- 6 In the tree, select **General > Pressure (Pa)**.
- 7 Click **OK**.
- 8 In the **Settings** window for **Global Equations**, locate the **Units** section.
- 9 Click  **Select Source Term Quantity**.
- 10 In the **Physical Quantity** dialog, type displacement in the text field.
- 11 In the tree, select **General > Displacement (m)**.
- 12 Click **OK**.

Before building the mesh and solving, create variables for the analytical expressions of inflation pressure and hoop stress for Ogden's model.

### DEFINITIONS

#### Variables I

- 1 In the **Model Builder** window, under **Component 1 (comp 1) > Definitions** click **Variables I**.
- 2 In the **Settings** window for **Variables**, locate the **Variables** section.

3 In the table, enter the following settings:

Name	Expression	Unit	Description
p_Ogden	$2*(H/Ri)*(mu1*(stretch^{(\alpha1-3)}-stretch^{(-2*\alpha1-3)})+mu2*(stretch^{(\alpha2-3)}-stretch^{(-2*\alpha2-3)})+mu3*(stretch^{(\alpha3-3)}-stretch^{(-2*\alpha3-3)}))$	Pa	Pressure (Ogden, analytical)
sp1_Ogden	$mu1*(stretch^{\alpha1}-stretch^{(-2*\alpha1)})+mu2*(stretch^{\alpha2}-stretch^{(-2*\alpha2)})+mu3*(stretch^{\alpha3}-stretch^{(-2*\alpha3)})$	Pa	Hoop stress (Ogden, analytical)

### MESH 1

#### *Mapped 1*

In the **Mesh** toolbar, click  **Mapped**.

#### *Distribution 1*

- 1 Right-click **Mapped 1** and choose **Distribution**.
- 2 Select Boundary 2 only.
- 3 In the **Settings** window for **Distribution**, locate the **Distribution** section.
- 4 In the **Number of elements** text field, type 3.

#### *Distribution 2*

- 1 In the **Model Builder** window, right-click **Mapped 1** and choose **Distribution**.
- 2 Select Boundary 3 only.
- 3 In the **Settings** window for **Distribution**, locate the **Distribution** section.
- 4 In the **Number of elements** text field, type 50.
- 5 In the **Model Builder** window, right-click **Mesh 1** and choose **Build All**.

### STUDY 1

The first study solves the problem with a neo-Hookean material model.

#### *Step 1: Stationary*

- 1 In the **Model Builder** window, under **Study 1** click **Step 1: Stationary**.
- 2 In the **Settings** window for **Stationary**, locate the **Physics and Variables Selection** section.
- 3 Select the **Modify model configuration for study step** checkbox.

- 4 In the tree, select **Component 1 (comp1) > Solid Mechanics (solid), Controls spatial frame > Mooney–Rivlin, Component 1 (comp1) > Solid Mechanics (solid), Controls spatial frame > Ogden**, and **Component 1 (comp1) > Solid Mechanics (solid), Controls spatial frame > Varga**.
- 5 Right-click and choose **Disable**.

Use an Auxiliary sweep to ramp the applied stretch from 1 to 10.

- 1 Click to expand the **Study Extensions** section. Select the **Auxiliary sweep** checkbox.
- 2 Click **+ Add**.
- 3 In the table, enter the following settings:

Parameter name	Parameter value list	Parameter unit
stretch (Applied stretch)	range(1, 0.1, 2) range(2.2, 0.2, 10)	1

- 4 In the **Model Builder** window, click **Study 1**.
- 5 In the **Settings** window for **Study**, type Neo-Hookean in the **Label** text field.
- 6 Locate the **Study Settings** section. Clear the **Generate default plots** checkbox.

Improve convergence by applying the following changes to the default solver.

#### *Solution 1 (sol1)*

- 1 In the **Study** toolbar, click  **Show Default Solver**.  
Use manual scaling to help the nonlinear solver during the first steps. A constant predictor is also suitable for nonlinear materials.
- 2 In the **Model Builder** window, expand the **Solution 1 (sol1)** node, then click **Dependent Variables 1**.
- 3 In the **Settings** window for **Dependent Variables**, locate the **Scaling** section.
- 4 From the **Method** list, choose **Manual**.
- 5 In the **Model Builder** window, expand the **Neo-Hookean > Solver Configurations > Solution 1 (sol1) > Stationary Solver 1** node, then click **Direct**.
- 6 In the **Settings** window for **Direct**, locate the **General** section.
- 7 From the **Solver** list, choose **PARDISO**.
- 8 In the **Model Builder** window, under **Neo-Hookean > Solver Configurations > Solution 1 (sol1) > Stationary Solver 1** click **Parametric 1**.
- 9 In the **Settings** window for **Parametric**, click to expand the **Continuation** section.
- 10 From the **Predictor** list, choose **Constant**.

- 11 In the **Model Builder** window, under **Neo-Hookean > Solver Configurations > Solution 1 (sol1) > Stationary Solver 1** click **Fully Coupled 1**.
- 12 In the **Settings** window for **Fully Coupled**, click to expand the **Method and Termination** section.
- 13 From the **Nonlinear method** list, choose **Constant (Newton)**.
- 14 In the **Study** toolbar, click  **Compute**.

Add a second study to solve for the Mooney–Rivlin material model, then repeat the steps described above.

#### ADD STUDY

- 1 In the **Home** toolbar, click  **Add Study** to open the **Add Study** window.
- 2 Go to the **Add Study** window.
- 3 Find the **Studies** subsection. In the **Select Study** tree, select **General Studies > Stationary**.
- 4 Click the **Add Study** button in the window toolbar.

#### MOONEY–RIVLIN

- 1 In the **Settings** window for **Study**, type Mooney-Rivlin in the **Label** text field.
- 2 Locate the **Study Settings** section. Clear the **Generate default plots** checkbox.

##### *Step 1: Stationary*



- 1 In the **Model Builder** window, under **Mooney–Rivlin** click **Step 1: Stationary**.
- 2 In the **Settings** window for **Stationary**, locate the **Physics and Variables Selection** section.
- 3 Select the **Modify model configuration for study step** checkbox.
- 4 In the tree, select **Component 1 (comp1) > Solid Mechanics (solid), Controls spatial frame > Neo-Hookean, Component 1 (comp1) > Solid Mechanics (solid), Controls spatial frame > Ogden**, and **Component 1 (comp1) > Solid Mechanics (solid), Controls spatial frame > Varga**.
- 5 Right-click and choose **Disable**.

Use an Auxiliary sweep to ramp up the applied stretch from 1 to 5.

- 1 Locate the **Study Extensions** section. Select the **Auxiliary sweep** checkbox.
- 2 Click  **Add**.
- 3 In the table, enter the following settings:

Parameter name	Parameter value list	Parameter unit
stretch (Applied stretch)	range(1, 0.1, 5)	1

### *Solution 2 (sol2)*

- 1 In the **Study** toolbar, click  **Show Default Solver**.
- 2 In the **Model Builder** window, expand the **Solution 2 (sol2)** node, then click **Dependent Variables 1**.
- 3 In the **Settings** window for **Dependent Variables**, locate the **Scaling** section.
- 4 From the **Method** list, choose **Manual**.
- 5 In the **Model Builder** window, expand the **Mooney–Rivlin > Solver Configurations > Solution 2 (sol2) > Stationary Solver 1** node, then click **Direct**.
- 6 In the **Settings** window for **Direct**, locate the **General** section.
- 7 From the **Solver** list, choose **PARDISO**.
- 8 In the **Model Builder** window, under **Mooney–Rivlin > Solver Configurations > Solution 2 (sol2) > Stationary Solver 1** click **Parametric 1**.
- 9 In the **Settings** window for **Parametric**, locate the **Continuation** section.
- 10 From the **Predictor** list, choose **Constant**.
- 11 In the **Model Builder** window, under **Mooney–Rivlin > Solver Configurations > Solution 2 (sol2) > Stationary Solver 1** click **Fully Coupled 1**.
- 12 In the **Settings** window for **Fully Coupled**, locate the **Method and Termination** section.
- 13 From the **Nonlinear method** list, choose **Constant (Newton)**.
- 14 In the **Study** toolbar, click  **Compute**.

Continue with a third study for the Ogden material model.

### **ADD STUDY**



- 1 Go to the **Add Study** window.
- 2 Find the **Studies** subsection. In the **Select Study** tree, select **General Studies > Stationary**.
- 3 Click the **Add Study** button in the window toolbar.

### **OGDEN**

- 1 In the **Settings** window for **Study**, type Ogden in the **Label** text field.
- 2 Locate the **Study Settings** section. Clear the **Generate default plots** checkbox.



### *Step 1: Stationary*

- 1 In the **Model Builder** window, under **Ogden** click **Step 1: Stationary**.
- 2 In the **Settings** window for **Stationary**, locate the **Physics and Variables Selection** section.
- 3 Select the **Modify model configuration for study step** checkbox.

- 4 In the tree, select **Component 1 (comp1) > Solid Mechanics (solid), Controls spatial frame > Neo-Hookean, Component 1 (comp1) > Solid Mechanics (solid), Controls spatial frame > Mooney–Rivlin**, and **Component 1 (comp1) > Solid Mechanics (solid), Controls spatial frame > Varga**.
- 5 Click  **Disable**.
- 6 Locate the **Study Extensions** section. Select the **Auxiliary sweep** checkbox.
- 7 Click  **Add**.
- 8 In the table, enter the following settings:

Parameter name	Parameter value list	Parameter unit
stretch (Applied stretch)	range(1, 0.1, 2) range(2.2, 0.2, 10)	1

*Solution 3 (sol3)*

- 1 In the **Study** toolbar, click  **Show Default Solver**.
- 2 In the **Model Builder** window, expand the **Solution 3 (sol3)** node, then click **Dependent Variables 1**.
- 3 In the **Settings** window for **Dependent Variables**, locate the **Scaling** section.
- 4 From the **Method** list, choose **Manual**.
- 5 In the **Model Builder** window, expand the **Ogden > Solver Configurations > Solution 3 (sol3) > Stationary Solver 1** node, then click **Direct**.
- 6 In the **Settings** window for **Direct**, locate the **General** section.
- 7 From the **Solver** list, choose **PARDISO**.
- 8 In the **Model Builder** window, under **Ogden > Solver Configurations > Solution 3 (sol3) > Stationary Solver 1** click **Parametric 1**.
- 9 In the **Settings** window for **Parametric**, locate the **Continuation** section.
- 10 From the **Predictor** list, choose **Constant**.
- 11 In the **Model Builder** window, under **Ogden > Solver Configurations > Solution 3 (sol3) > Stationary Solver 1** click **Fully Coupled 1**.
- 12 In the **Settings** window for **Fully Coupled**, locate the **Method and Termination** section.
- 13 From the **Nonlinear method** list, choose **Constant (Newton)**.
- 14 In the **Study** toolbar, click  **Compute**.

Finally, add a fourth study for the Varga material model.



## ADD STUDY

- 1 Go to the **Add Study** window.
- 2 Find the **Studies** subsection. In the **Select Study** tree, select **General Studies > Stationary**.
- 3 Click the **Add Study** button in the window toolbar.
- 4 In the **Home** toolbar, click  **Add Study** to close the **Add Study** window.

## STUDY 4

- 1 In the **Settings** window for **Study**, locate the **Study Settings** section.
- 2 Clear the **Generate default plots** checkbox.

### Step 1: Stationary

- 1 In the **Model Builder** window, under **Study 4** click **Step 1: Stationary**.
- 2 In the **Settings** window for **Stationary**, locate the **Physics and Variables Selection** section.
- 3 Select the **Modify model configuration for study step** checkbox.
- 4 In the tree, select **Component 1 (comp1) > Solid Mechanics (solid), Controls spatial frame > Neo-Hookean, Component 1 (comp1) > Solid Mechanics (solid), Controls spatial frame > Mooney–Rivlin**, and **Component 1 (comp1) > Solid Mechanics (solid), Controls spatial frame > Ogden**.
- 5 Click  **Disable**.
- 6 Locate the **Study Extensions** section. Select the **Auxiliary sweep** checkbox.
- 7 Click  **Add**.
- 8 In the table, enter the following settings:

Parameter name	Parameter value list	Parameter unit
stretch (Applied stretch)	range(1, 0.1, 2) range(2.2, 0.2, 7)	1

- 9 In the **Model Builder** window, click **Study 4**.
- 10 In the **Settings** window for **Study**, type Varga in the **Label** text field.



### Solution 4 (sol4)

- 1 In the **Study** toolbar, click  **Show Default Solver**.
- 2 In the **Model Builder** window, expand the **Solution 4 (sol4)** node, then click **Dependent Variables 1**.
- 3 In the **Settings** window for **Dependent Variables**, locate the **Scaling** section.
- 4 From the **Method** list, choose **Manual**.

- 5 In the **Model Builder** window, expand the **Varga > Solver Configurations > Solution 4 (sol4) > Stationary Solver I** node, then click **Direct**.
  - 6 In the **Settings** window for **Direct**, locate the **General** section.
  - 7 In the **Memory allocation factor** text field, type 2. 1.
  - 8 In the **Model Builder** window, under **Varga > Solver Configurations > Solution 4 (sol4) > Stationary Solver I** click **Parametric I**.
  - 9 In the **Settings** window for **Parametric**, locate the **Continuation** section.
  - 10 From the **Predictor** list, choose **Constant**.
  - 11 In the **Model Builder** window, under **Varga > Solver Configurations > Solution 4 (sol4) > Stationary Solver I** click **Fully Coupled I**.
  - 12 In the **Settings** window for **Fully Coupled**, locate the **Method and Termination** section.
  - 13 From the **Nonlinear method** list, choose **Constant (Newton)**.
  - 14 In the **Study** toolbar, click  **Compute**.
- Set default units for result presentation.

## RESULTS

### *Preferred Units I*

- 1 In the **Results** toolbar, click  **Configurations** and choose **Preferred Units**.
- 2 In the **Settings** window for **Preferred Units**, locate the **Units** section.
- 3 Click  **Add Physical Quantity**.
- 4 In the **Physical Quantity** dialog, select **General > Pressure (Pa)** in the tree.
- 5 Click **OK**.
- 6 In the **Settings** window for **Preferred Units**, locate the **Units** section.
- 7 In the table, enter the following settings:
 

Quantity	Unit	Preferred unit
Pressure	Pa	kPa
- 8 Click  **Add Physical Quantity**.
- 9 In the **Physical Quantity** dialog, select **Solid Mechanics > Stress tensor (N/m<sup>2</sup>)** in the tree.
- 10 Click **OK**.
- 11 In the **Settings** window for **Preferred Units**, locate the **Units** section.



12 In the table, enter the following settings:

Quantity	Unit	Preferred unit
Stress tensor	N/m <sup>2</sup>	MPa

13 Click  **Apply**.

### RESULT TEMPLATES

First, add a plot from **Result Templates** to be used for the first principal stress on the 2D axisymmetric cross section for the neo-Hookean material at maximum inflation. When you adjust the scaling, the plot should become similar to [Figure 5](#).

- 1 In the **Results** toolbar, click  **Result Templates** to open the **Result Templates** window.
- 2 Go to the **Result Templates** window.
- 3 In the tree, select **Neo-Hookean/Solution 1 (sol1) > Solid Mechanics > Stress (solid)**.
- 4 Click the **Add Result Template** button in the window toolbar.
- 5 In the **Results** toolbar, click  **Result Templates** to close the **Result Templates** window.

### RESULTS



#### *Stress (solid)*

- 1 In the **Stress (solid)** toolbar, click  **Plot**.
- 2 In the **Model Builder** window, click **Stress (solid)**.
- 3 In the **Settings** window for **2D Plot Group**, locate the **Plot Settings** section.
- 4 From the **Frame** list, choose **Material (R, PHI, Z)**.

#### *Surface 1*

- 1 In the **Model Builder** window, expand the **Stress (solid)** node, then click **Surface 1**.
- 2 In the **Settings** window for **Surface**, locate the **Expression** section.
- 3 In the **Expression** text field, type `solid.sp1`.

#### *Deformation*

- 1 In the **Model Builder** window, expand the **Surface 1** node, then click **Deformation**.
- 2 In the **Settings** window for **Deformation**, locate the **Scale** section.
- 3 In the **Scale factor** text field, type `0.05`.
- 4 In the **Stress (solid)** toolbar, click  **Plot**.
- 5 Click the  **Zoom Extents** button in the **Graphics** toolbar.

Add a **ID Plot Group** to display the relation between inflation pressure and stretch shown in [Figure 3](#).

#### *Inflation Pressure*

- 1 In the **Home** toolbar, click  **Add Plot Group** and choose **ID Plot Group**.
- 2 In the **Settings** window for **ID Plot Group**, type Inflation Pressure in the **Label** text field.
- 3 Locate the **Plot Settings** section.
- 4 Select the **y-axis label** checkbox. In the associated text field, type Inflation pressure (kPa).
- 5 Click to expand the **Title** section. From the **Title type** list, choose **Manual**.
- 6 In the **Title** text area, type Inflation Pressure vs. Stretch.

#### *Point Graph 1*

- 1 Right-click **Inflation Pressure** and choose **Point Graph**.
- 2 In the **Settings** window for **Point Graph**, locate the **Data** section.
- 3 From the **Dataset** list, choose **Neo-Hookean/Solution 1 (sol1)**.
- 4 Select Point 3 only.
- 5 Locate the **y-Axis Data** section. In the **Expression** text field, type  $p_f$ .
- 6 From the **Unit** list, choose **kPa**.
- 7 Click **Replace Expression** in the upper-right corner of the **x-Axis Data** section. From the menu, choose **Global definitions > Parameters > stretch - Applied stretch - 1**.
- 8 Click to expand the **Legends** section. Select the **Show legends** checkbox.
- 9 From the **Legends** list, choose **Manual**.
- 10 In the table, enter the following settings:

---

**Legends**

---

Neo-Hookean

---

- 11 In the **Inflation Pressure** toolbar, click  **Plot**.

#### *Point Graph 2*

- 1 Right-click **Point Graph 1** and choose **Duplicate**.
- 2 In the **Settings** window for **Point Graph**, locate the **Data** section.
- 3 From the **Dataset** list, choose **Mooney–Rivlin/Solution 2 (sol2)**.

4 Locate the **Legends** section. In the table, enter the following settings:

---

<b>Legends</b>
Mooney-Rivlin

---

5 In the **Inflation Pressure** toolbar, click  **Plot**.

#### *Point Graph 3*

1 In the **Model Builder** window, under **Results > Inflation Pressure** right-click **Point Graph 1** and choose **Duplicate**.

2 In the **Settings** window for **Point Graph**, locate the **Data** section.

3 From the **Dataset** list, choose **Ogden/Solution 3 (sol3)**.

4 Locate the **Legends** section. In the table, enter the following settings:

---

<b>Legends</b>
Ogden

---

5 In the **Inflation Pressure** toolbar, click  **Plot**.

#### *Point Graph 4*

1 Right-click **Point Graph 1** and choose **Duplicate**.

2 In the **Settings** window for **Point Graph**, locate the **Data** section.

3 From the **Dataset** list, choose **Varga/Solution 4 (sol4)**.

4 Locate the **Legends** section. In the table, enter the following settings:

---

<b>Legends</b>
Varga

---

5 In the **Inflation Pressure** toolbar, click  **Plot**.

#### *Point Graph 5*

1 Right-click **Point Graph 1** and choose **Duplicate**.

2 In the **Settings** window for **Point Graph**, locate the **Data** section.

3 From the **Dataset** list, choose **Ogden/Solution 3 (sol3)**.

4 Locate the **y-Axis Data** section. In the **Expression** text field, type `p_Ogden`.

5 Click to expand the **Coloring and Style** section. Find the **Line style** subsection. From the **Line** list, choose **None**.

6 From the **Color** list, choose **From theme**.

7 Find the **Line markers** subsection. From the **Marker** list, choose **Asterisk**.

- 8 From the **Positioning** list, choose **Interpolated**.
- 9 In the **Number** text field, type 40.
- 10 Locate the **Legends** section. In the table, enter the following settings:

<b>Legends</b>
Analytical (Ogden)

- 11 In the **Inflation Pressure** toolbar, click  **Plot**.

To reproduce [Figure 4](#), proceed as follows.

#### *First Principal Stress*

- 1 In the **Model Builder** window, right-click **Inflation Pressure** and choose **Duplicate**.
- 2 In the **Settings** window for **ID Plot Group**, type First Principal Stress in the **Label** text field.
- 3 Locate the **Title** section. In the **Title** text area, type First Principal Stress vs. Stretch.
- 4 Locate the **Plot Settings** section. In the **y-axis label** text field, type First principal stress (MPa).
- 5 Locate the **Axis** section. Select the **Manual axis limits** checkbox.
- 6 In the **y maximum** text field, type 40.

#### *Point Graph 1*

- 1 In the **Model Builder** window, expand the **First Principal Stress** node, then click **Point Graph 1**.
- 2 In the **Settings** window for **Point Graph**, locate the **y-Axis Data** section.
- 3 In the **Expression** text field, type `solid.sp1`.

#### *Point Graph 2*

- 1 In the **Model Builder** window, click **Point Graph 2**.
- 2 In the **Settings** window for **Point Graph**, locate the **y-Axis Data** section.
- 3 In the **Expression** text field, type `solid.sp1`.

#### *Point Graph 3*

- 1 In the **Model Builder** window, click **Point Graph 3**.
- 2 In the **Settings** window for **Point Graph**, locate the **y-Axis Data** section.
- 3 In the **Expression** text field, type `solid.sp1`.

#### *Point Graph 4*

- 1 In the **Model Builder** window, click **Point Graph 4**.
- 2 In the **Settings** window for **Point Graph**, locate the **y-Axis Data** section.
- 3 In the **Expression** text field, type `solid.sp1`.

Apply preferred units to change from kPa to MPa in the principal stress plot.

#### *Preferred Units 1*

- 1 In the **Model Builder** window, under **Results > Configurations** click **Preferred Units 1**.
- 2 In the **Settings** window for **Preferred Units**, click  **Apply**.

#### *Point Graph 5*

- 1 In the **Model Builder** window, under **Results > First Principal Stress** click **Point Graph 5**.
- 2 In the **Settings** window for **Point Graph**, locate the **y-Axis Data** section.
- 3 In the **Expression** text field, type `sp1_0gden`.
- 4 From the **Unit** list, choose **MPa**.
- 5 In the **First Principal Stress** toolbar, click  **Plot**.