



Model created in COMSOL Multiphysics 6.4

Stresses and Strains in a Wrench

Introduction

This tutorial demonstrates how to set up a simple static structural analysis. The analysis is exemplified on a combination wrench during the application of torque on a bolt.

Despite its simplicity, and the fact that very few engineers would run a structural analysis before trying to turn a bolt, the example provides an excellent overview of structural analysis in COMSOL Multiphysics.



Another, more extensive variant of this tutorial is available in the *Introduction to COMSOL Multiphysics* document.

Model Definition

The model geometry is shown below.

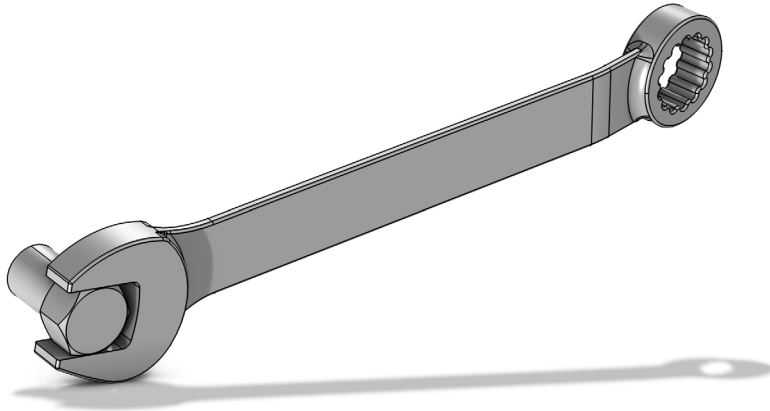

The bolt's fixed constraint is at the cross section shown below. A load is applied at the box end of the combination wrench.

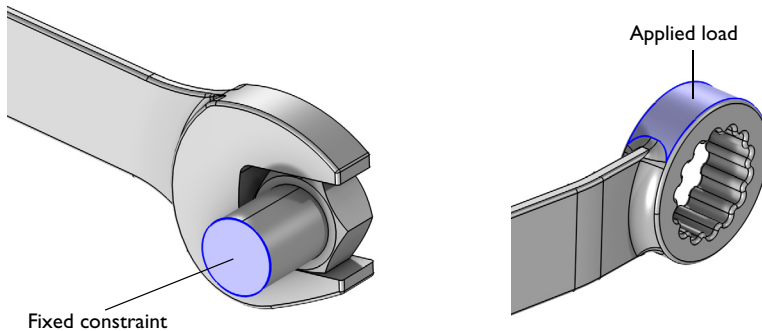

Here, assume that there is perfect contact between the wrench and the bolt. A possible extension is to apply a contact condition between the wrench and the bolt where the friction and the contact pressure determines the position of the contact surface.

Application Library path: COMSOL_Multiphysics/Structural_Mechanics/wrench



Modeling Instructions

From the **File** menu, choose **New**.

NEW





In the **New** window, click  **Model Wizard**.

MODEL WIZARD

- 1 In the **Model Wizard** window, click  **3D**.
- 2 In the **Select Physics** tree, select **Structural Mechanics > Solid Mechanics (solid)**.
- 3 Click **Add**.
- 4 Click  **Study**.
- 5 In the **Select Study** tree, select **General Studies > Stationary**.
- 6 Click  **Done**.



GEOMETRY I

Import I (impl)

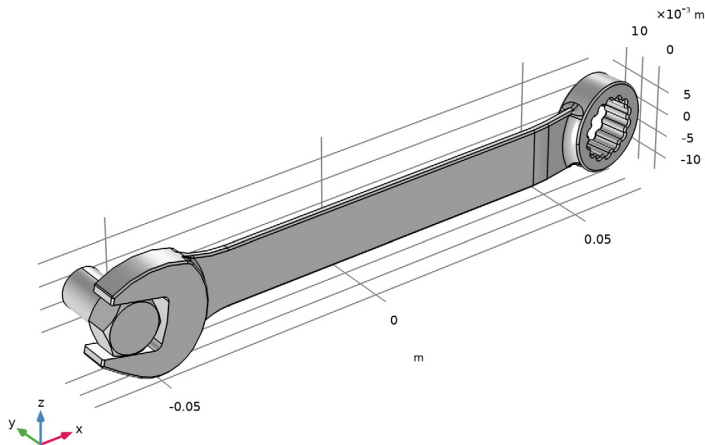
- 1 In the **Geometry** toolbar, click  **Import**.
- 2 In the **Settings** window for **Import**, locate the **Source** section.
- 3 Click  **Browse**.
- 4 Browse to the model's Application Libraries folder and double-click the file wrench.mphbin.
- 5 Click  **Build All Objects**.
- 6 Click the  **Zoom Extents** button in the **Graphics** toolbar.





Boundary load



- 1 In the **Geometry** toolbar, click  **Selections** and choose **Explicit Selection**.
- 2 In the **Settings** window for **Explicit Selection**, type Boundary load in the **Label** text field.
- 3 Locate the **Entities to Select** section. From the **Geometric entity level** list, choose **Boundary**.
- 4 On the object **impl**, select Boundary 111 only.
- 5 Click  **Build Selected**.

Fixed constraint

- 1 In the **Geometry** toolbar, click  **Selections** and choose **Explicit Selection**.

- 2 In the **Settings** window for **Explicit Selection**, type **Fixed** constraint in the **Label** text field.
- 3 Locate the **Entities to Select** section. From the **Geometric entity level** list, choose **Boundary**.
- 4 Click the  **Wireframe Rendering** button in the **Graphics** toolbar.
- 5 On the object **impl**, select **Boundary 35** only.
- 6 Click the  **Wireframe Rendering** button in the **Graphics** toolbar to turn off wireframe rendering.

ADD MATERIAL

- 1 In the **Materials** toolbar, click  **Add Material** to open the **Add Material** window.
- 2 Go to the **Add Material** window.
- 3 In the tree, select **Built-in** > **Structural steel**.
- 4 Click the **Add to Component** button in the window toolbar.
- 5 In the **Geometry Cleanup** dialog that opens, click **Clean Up Automatically** to automatically clean up the geometry by removing some narrow face regions.
- 6 In the **Materials** toolbar, click  **Add Material** to close the **Add Material** window.

GLOBAL DEFINITIONS

Parameters /

- 1 In the **Settings** window for **Parameters**, locate the **Parameters** section.
- 2 In the table, enter the following settings:

Name	Expression	Value	Description
F	150[N]	150 N	Applied force

SOLID MECHANICS (SOLID)

Fixed Constraint /

- 1 In the **Physics** toolbar, click  **Boundaries** and choose **Fixed Constraint**.
- 2 In the **Settings** window for **Fixed Constraint**, locate the **Boundary Selection** section.
- 3 From the **Selection** list, choose **Fixed constraint**.

Boundary Load /

- 1 In the **Physics** toolbar, click  **Boundaries** and choose **Boundary Load**.
- 2 In the **Settings** window for **Boundary Load**, locate the **Boundary Selection** section.

- 3 From the **Selection** list, choose **Boundary load**.
- 4 Locate the **Force** section. From the **Load type** list, choose **Total force**.
- 5 Specify the \mathbf{F}_{tot} vector as

0	x
0	y
-F	z

The minus sign means that the force is applied downward.

MESH 1

- 1 In the **Model Builder** window, under **Component 1 (comp1)** click **Mesh 1**.
- 2 In the **Settings** window for **Mesh**, locate the **Physics-Controlled Mesh** section.
- 3 From the **Element size** list, choose **Normal**.

STUDY 1

If your computer has more than 16 GB of RAM, you can skip the following four instructions and continue directly to the section [Compute the Solution](#). Otherwise, follow these steps to use an iterative solver:

Solution 1 (sol1)

- 1 In the **Study** toolbar, click  **Show Default Solver**.
- 2 In the **Model Builder** window, expand the **Solution 1 (sol1)** node.
- 3 In the **Model Builder** window, expand the **Study 1 > Solver Configurations > Solution 1 (sol1) > Stationary Solver 1** node.
- 4 Right-click **Study 1 > Solver Configurations > Solution 1 (sol1) > Stationary Solver 1 > Suggested Iterative Solver (solid)** and choose **Enable**.

Iterative solvers require less memory but can be less robust than direct solvers.

COMPUTE THE SOLUTION



In the **Study** toolbar, click  **Compute**.

RESULTS

Stress (solid)

The default plot group shows the von Mises stress in a **Surface** plot with the displacement visualized using a **Deformation** subnode. Change to a more suitable unit as follows.

Volume 1

- 1 In the **Model Builder** window, expand the **Results > Stress (solid)** node, then click **Volume 1**.
- 2 In the **Settings** window for **Volume**, locate the **Expression** section.
- 3 From the **Unit** list, choose **MPa**.
- 4 In the **Stress (solid)** toolbar, click  **Plot**.
- 5 Click the  **Zoom Extents** button in the **Graphics** toolbar.

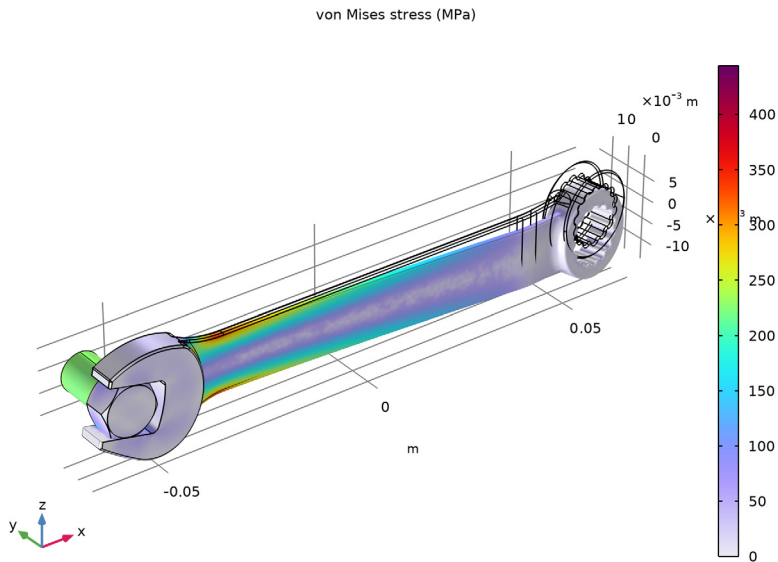

First Principal Strain

- 1 In the **Model Builder** window, right-click **Stress (solid)** and choose **Duplicate**.
- 2 In the **Settings** window for **3D Plot Group**, type **First Principal Strain** in the **Label** text field.

Volume 1

- 1 In the **Model Builder** window, expand the **First Principal Strain** node, then click **Volume 1**.
- 2 In the **Settings** window for **Volume**, click **Replace Expression** in the upper-right corner of the **Expression** section. From the menu, choose **Component 1 (comp1) > Solid Mechanics > Strain > Principal strains > solid.ep1 - First principal strain - 1**.

3 In the **First Principal Strain** toolbar, click  **Plot**.

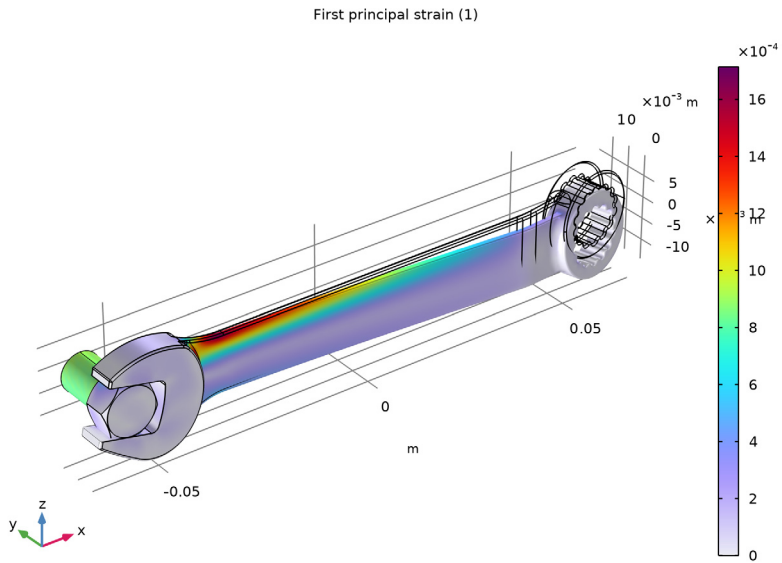

Notice that the maximum principal strain is about 2%, a result that satisfies the small strain assumption.