



Model created in COMSOL Multiphysics 6.4

Eigenvalue Analysis of a Turbocharger Rotor

Introduction

In this tutorial model, an eigenvalue analysis of a turbocharger rotor is performed. The rotor is analyzed in an unconstrained configuration, also commonly known as free-free conditions. A rotor like this is usually intended for high-speed applications, but here the analysis is performed at standstill.

This example also illustrates how a mesh on NASTRAN format can be imported in COMSOL Multiphysics.

Model Definition

Roughly speaking, the turbocharger rotor consists of three main components: a shaft, a turbine wheel, and a compressor wheel. These components are usually manufactured in metal alloys tailored for high-temperature applications. However, for simplicity, we here assume that the assembly is made of a standard structural steel. For an eigenfrequency analysis, the only important parameter is the ratio between Young's modulus and mass density.

The geometry is created from a mesh NASTRAN on format, which you can import into the COMSOL Desktop. The imported mesh is visualized in [Figure 1](#). Note that the geometry unit is millimeters.

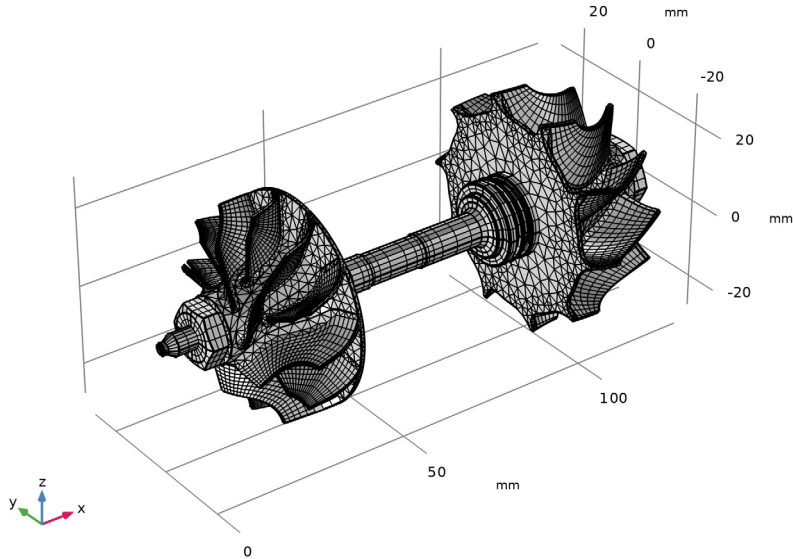

Figure 1: The mesh of the turbocharger rotor.

Results and Discussion

The eigenfrequency analysis conducted in the model yields the twelve lowest eigenfrequencies, and their associated mode shapes. Given that the turbocharger rotor is analyzed in an unconstrained configuration, six of these eigenmodes have zero-valued eigenfrequencies. In a structural mechanics context, these are often referred to as *rigid body modes*.

In addition, six nonrigid modes are obtained from the analysis. Since these are usually of greater interest, we will here focus on those.

Figure 2 shows the mode shape related to the first nonrigid eigenmode. The associated eigenfrequency is approximately 1150 Hz. This is found to be the first torsional mode.

Eigenfrequency=1149.8 Hz Surface: Displacement magnitude (mm) Arrow Line: Displacement field

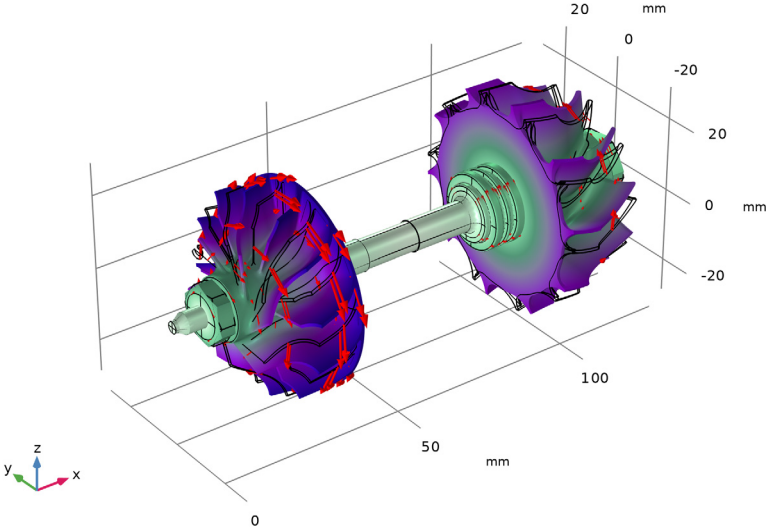

Figure 2: The mode shape associated with the first nonrigid eigenmode.

Figure 3 shows the mode shape of the second nonrigid eigenmode. This is the first bending mode. This mode has eigenfrequency of approximately 1163 Hz.

Eigenfrequency=1162.5 Hz Surface: Displacement magnitude (mm) Arrow Line: Displacement field

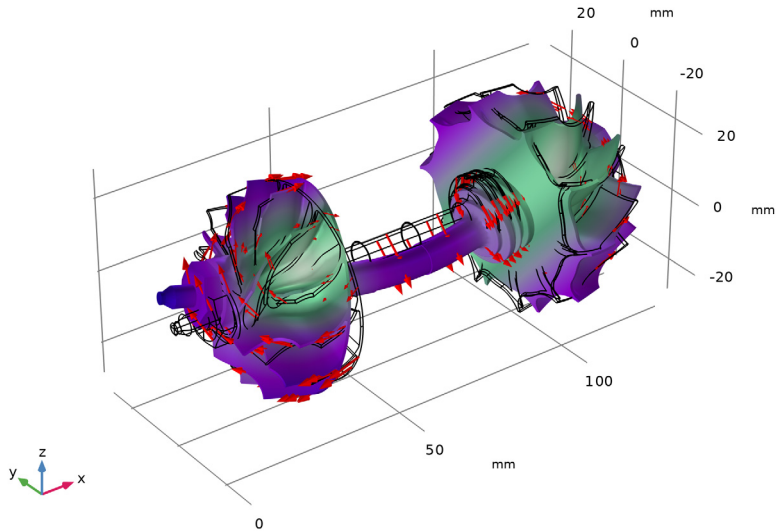

Figure 3: The mode shape associated with the second nonrigid eigenmode.

All eigenfrequencies associated with the nonrigid eigenmodes are summarized in Table 1.

TABLE 1: EIGENFREQUENCIES OF NONRIGID EIGENMODES.

Mode no.	Eigenfrequency (Hz)	Characteristics
1	1150	First torsional mode
2	1163	First bending mode
3	1163	First bending mode (perpendicular plane)
4	3399	Second bending mode
5	3400	Second bending mode (perpendicular plane)
6	7641	First longitudinal mode



Application Library path: COMSOL_Multiphysics/Structural_Mechanics/
turbocharger_rotor

From the **File** menu, choose **New**.

NEW

In the **New** window, click  **Model Wizard**.

MODEL WIZARD

- 1 In the **Model Wizard** window, click  **3D**.
- 2 In the **Select Physics** tree, select **Structural Mechanics > Solid Mechanics (solid)**.
- 3 Click **Add**.
- 4 Click  **Study**.
- 5 In the **Select Study** tree, select **General Studies > Eigenfrequency**.
- 6 Click  **Done**.



GEOMETRY I

Import a NASTRAN mesh file under the **Mesh** node. In addition to the mesh, this will create geometrical objects like domains and boundaries. Before importing the file, select millimeters as the length unit to get the correct size for the geometry.



- 1 In the **Model Builder** window, under **Component 1 (comp1)** click **Geometry 1**.
- 2 In the **Settings** window for **Geometry**, locate the **Units** section.
- 3 From the **Length unit** list, choose **mm**.

MESH I

Import 1

- 1 In the **Mesh** toolbar, click  **Import**.
- 2 In the **Settings** window for **Import**, locate the **Import** section.
- 3 From the **Source** list, choose **NASTRAN file**.
- 4 From the **Data to import** list, choose **Only mesh**.
- 5 Click  **Browse**.
- 6 Browse to the model's Application Libraries folder and double-click the file `turbocharger_rotor.nas`.
- 7 Click  **Import**.

ADD MATERIAL

- 1 In the **Materials** toolbar, click  **Add Material** to open the **Add Material** window.
- 2 Go to the **Add Material** window.
- 3 In the tree, select **Built-in > Structural steel**.
- 4 Click the **Add to Component** button in the window toolbar.
- 5 In the **Materials** toolbar, click  **Add Material** to close the **Add Material** window.

To perform the eigenfrequency analysis under unconstrained conditions, no changes are required in the physics interface. You are thus ready to conduct the eigenfrequency analysis.

STUDY I

Increase the desired number of eigenfrequencies to 12. This will give you six rigid-body modes along with six nonrigid modes.

Step 1: Eigenfrequency

- 1 In the **Model Builder** window, under **Study I** click **Step 1: Eigenfrequency**.
- 2 In the **Settings** window for **Eigenfrequency**, locate the **Study Settings** section.
- 3 Select the **Desired number of eigenfrequencies** checkbox. In the associated text field, type 12.
- 4 In the **Study** toolbar, click  **Compute**.

RESULTS

Mode Shape (solid)



The default plot shows the displacement magnitude on top of the deformed shape of the first mode, which in this case is a rigid-body mode. To get a plot showing another eigenmode, you can follow the instructions below. These will give you a plot of the first nonrigid mode.

- 1 In the **Settings** window for **3D Plot Group**, locate the **Data** section.
- 2 From the **Eigenfrequency (Hz)** list, choose **1149.8**.

Add a displacement arrow plot for better visualization of the mode type.

Arrow Line 1

- 1 Right-click **Mode Shape (solid)** and choose **Arrow Line**.
- 2 In the **Settings** window for **Arrow Line**, locate the **Arrow Positioning** section.
- 3 In the **Number of arrows** text field, type 400.

- 4 Locate the **Coloring and Style** section.
- 5 Select the **Scale factor** checkbox. In the associated text field, type $7e4$.
- 6 In the **Mode Shape (solid)** toolbar, click  **Plot**.
- 7 Click the  **Go to Default View** button in the **Graphics** toolbar.

The resulting plot should be similar to the one shown below. The mode is a torsional mode.

Eigenfrequency=1149.8 Hz Surface: Displacement magnitude (mm) Arrow Line: Displacement field

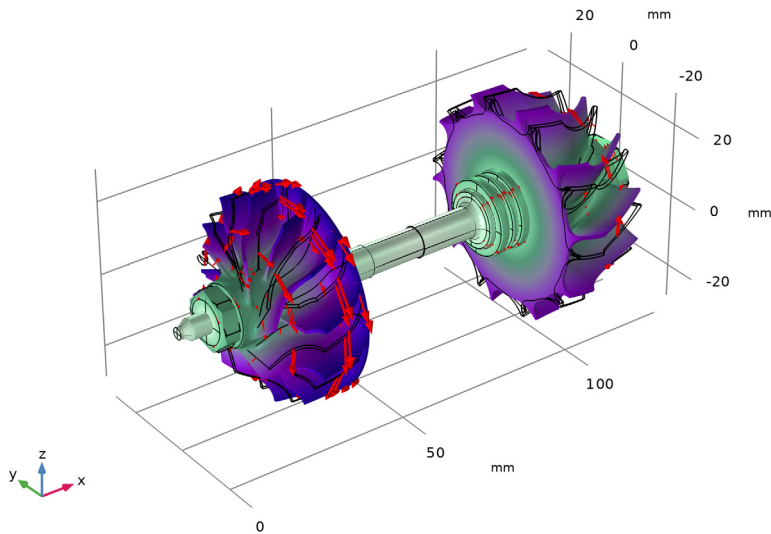

Now, select the second nonrigid mode. This corresponds to the eighth eigenfrequency in the list.

Mode Shape (solid)

- 1 In the **Model Builder** window, click **Mode Shape (solid)**.
- 2 In the **Settings** window for **3D Plot Group**, locate the **Data** section.
- 3 From the **Eigenfrequency (Hz)** list, choose **1162.5**.

4 In the **Mode Shape (solid)** toolbar, click  **Plot**.

The resulting plot should be similar to the one shown below. The second nonrigid mode is the first bending mode.

Eigenfrequency=1162.5 Hz Surface: Displacement magnitude (mm) Arrow Line: Displacement field

