

Model created in COMSOL Multiphysics 6.4

Tuning Fork

Introduction

This example simulates a tuning fork for tuning musical instruments and, if correctly design, should sound the note of A, 440 Hz. It computes the fundamental eigenfrequency and eigenmode for the tuning fork. Although the example seems to be somewhat academic in nature, the eigenfrequencies and eigenmodes of microscopic tuning forks are also used in quartz watches and other electronic devices.

Model Definition

The model geometry is shown in [Figure 1](#). The fundamental frequency of the fork is determined by the length of the prongs, the cross-section geometry of the prongs, and the material properties of the fork.

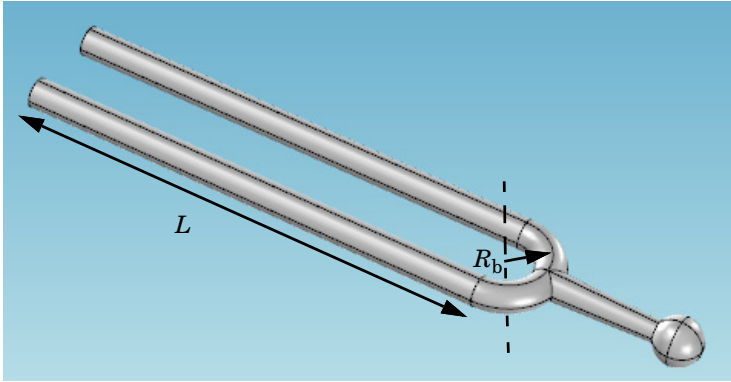

Figure 1: Tuning fork geometry.

The following formula gives a theoretical estimation for the fundamental frequency of a tuning fork with cylindrical cross section of the prong ([Ref. 1](#)):

$$f = \frac{1.875^2 R_p}{4\pi L_p^2} \sqrt{\frac{E}{\rho}} \quad (1)$$

where R_p is the radius of the cross section of the prongs, E denotes Young's modulus, and ρ is the density. The length of the prong can be estimated as

$$L_p = L + \frac{1}{2}\pi R_b \quad (2)$$

where R_b the radius of the base and L is the length of the straight cylindrical part; see Figure 1.

In the fundamental eigenmode, the prongs move according to the figure below. Thus, the eigenmode is symmetric with a symmetry plane placed between the prongs.

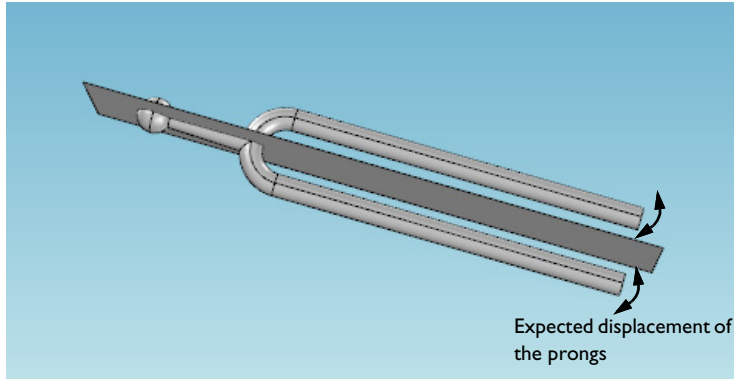

The advantage with the shape of the fundamental eigenmode is that the relative displacements in the handle are very small, which makes it possible to hold the fork without damping the vibration. This also allows to make use of the theoretical estimation for the frequency Equation 1 which is based on the solution for a cantilever beam representing each prong.

The parameters used in the model are: $R_b = 7.5$ mm and $R_p = 2.5$ mm. The fork material is Steel AISI 4340, for which $E = 205$ GPa and $\rho = 7850$ kg/m³.

For the frequency $f = 440$ Hz, Equation 1 and Equation 2 give the length of the prong cylindrical part as $L = 7.8$ cm. This presents an underestimation because the part of the prong near the base has larger bending stiffness compared to that for a straight cantilever beam.

To fine-tune the fork, you will use parameterized geometry and gradually increase the cylinder length starting from the above given estimation. To achieve this, you set up a parametric sweep with respect to the parameter L .

Reference

1. *Tuning fork*, en.wikipedia.org/wiki/Tuning_fork

Application Library path: COMSOL_Multiphysics/Structural_Mechanics/
tuning_fork



Modeling Instructions

From the **File** menu, choose **New**.

NEW

In the **New** window, click  **Model Wizard**.

MODEL WIZARD

- 1 In the **Model Wizard** window, click  **3D**.
- 2 In the **Select Physics** tree, select **Structural Mechanics > Solid Mechanics (solid)**.
- 3 Click **Add**.
- 4 Click  **Study**.
- 5 In the **Select Study** tree, select **General Studies > Eigenfrequency**.
- 6 Click  **Done**.

GLOBAL DEFINITIONS

Parameters I

Define parameters for the relevant dimensions and positions for the tuning fork's components.

- 1 In the **Model Builder** window, under **Global Definitions** click **Parameters I**.
- 2 In the **Settings** window for **Parameters**, locate the **Parameters** section.
- 3 In the table, enter the following settings:

Name	Expression	Value	Description
L	78[mm]	0.078 m	Cylinder length
Rb	7.5[mm]	0.0075 m	Base radius
Rp	2.5[mm]	0.0025 m	Prong radius
Ls	20[mm]	0.02 m	Stem length
Rh	4[mm]	0.004 m	Handle radius
z0	-22.5[mm]	-0.0225 m	Vertical displacement, handle

GEOMETRY I

- 1 In the **Model Builder** window, under **Component 1 (comp1)** click **Geometry I**.
- 2 In the **Settings** window for **Geometry**, locate the **Units** section.
- 3 From the **Length unit** list, choose **mm** to better reflect the size of the fork.

You can build up the fork geometry efficiently using predefined geometric primitives.

Cone 1 (cone1)

- 1 In the **Geometry** toolbar, click  **Cone**.
- 2 In the **Settings** window for **Cone**, locate the **Size and Shape** section.
- 3 In the **Bottom radius** text field, type Rp.
- 4 In the **Height** text field, type Ls.
- 5 From the **Specify top size using** list, choose **Angle**.
- 6 In the **Semiangle** text field, type 2.
- 7 Locate the **Position** section. In the **x** text field, type Rb.
- 8 In the **z** text field, type -Rb.
- 9 Locate the **Axis** section. From the **Axis type** list, choose **Cartesian**.
- 10 In the **z** text field, type -1.

Sphere 1 (sph1)

- 1 In the **Geometry** toolbar, click  **Sphere**.
- 2 In the **Settings** window for **Sphere**, locate the **Size** section.
- 3 In the **Radius** text field, type Rh.
- 4 Locate the **Position** section. In the **x** text field, type Rb.
- 5 In the **z** text field, type z0-Rb.

Torus 1 (tor1)

- 1 In the **Geometry** toolbar, click  **Torus**.
- 2 In the **Settings** window for **Torus**, locate the **Size and Shape** section.
- 3 In the **Major radius** text field, type Rb.
- 4 In the **Minor radius** text field, type Rp.
- 5 In the **Revolution angle** text field, type 180.
- 6 Locate the **Position** section. In the **x** text field, type Rb.
- 7 Locate the **Axis** section. From the **Axis type** list, choose **Cartesian**.
- 8 In the **z** text field, type 0.

9 In the **y** text field, type 1.

10 Locate the **Rotation Angle** section. In the **Rotation** text field, type -90.

Union 1 (uni1)

1 In the **Geometry** toolbar, click  **Booleans and Partitions** and choose **Union**.

2 In the **Settings** window for **Union**, locate the **Union** section.

3 Clear the **Keep interior boundaries** checkbox.

4 Click in the **Graphics** window and then press Ctrl+A to select all objects.

This completes the handle and base of the fork.

Add two cylinders to represent the prongs.

Cylinder 1 (cyl1)

1 In the **Geometry** toolbar, click  **Cylinder**.

2 In the **Settings** window for **Cylinder**, locate the **Size and Shape** section.

3 In the **Radius** text field, type Rp.

4 In the **Height** text field, type L.

Cylinder 2 (cyl2)

1 In the **Geometry** toolbar, click  **Cylinder**.

2 In the **Settings** window for **Cylinder**, locate the **Size and Shape** section.

3 In the **Radius** text field, type Rp.

4 In the **Height** text field, type L.

5 Locate the **Position** section. In the **x** text field, type 2*Rp.

Use virtual geometry operations to avoid short edges and narrow regions. This will improve the mesh generation.

Ignore Edges 1 (ige1)

1 In the **Geometry** toolbar, click  **Virtual Operations** and choose **Ignore Edges**.

2 On the object **fin**, select Edges 22, 23, 29, 32, 33, 39, 42, and 43 only.

It might be easier to select the edges by using the **Selection List** window. To open this window, in the **Home** toolbar click **Windows** and choose **Selection List**. (If you are running the cross-platform desktop, you find **Windows** in the main menu.)

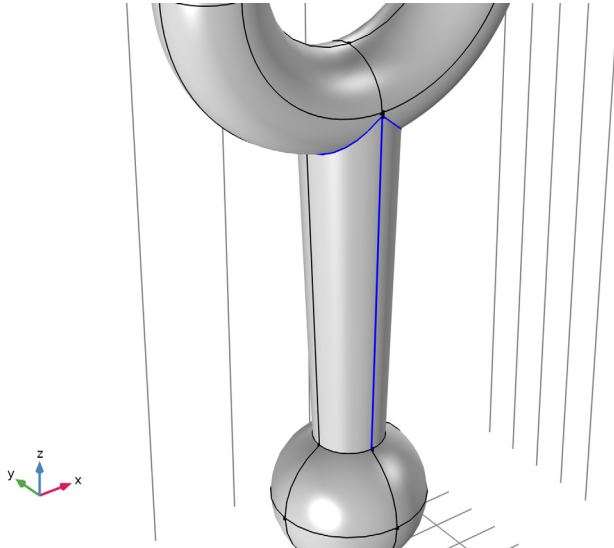



3 In the **Geometry** toolbar, click  **Build All**.

- 4 Click the  **Go to Default View** button in the **Graphics** toolbar.

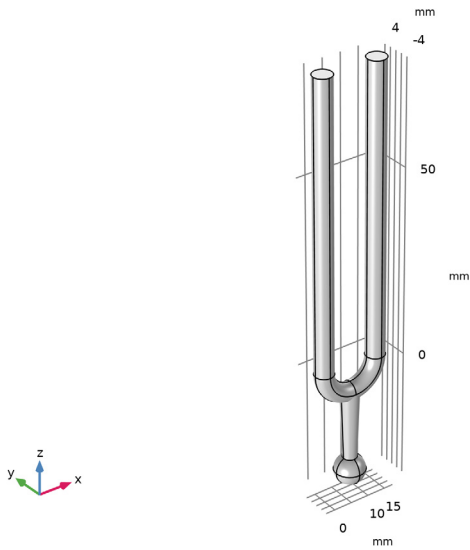
The completed geometry should look as shown in the following figure:



ADD MATERIAL

- 1 In the **Materials** toolbar, click  **Add Material** to open the **Add Material** window.
- 2 Go to the **Add Material** window.
- 3 In the tree, select **Built-in > Steel AISI 4340**.
- 4 Click the **Add to Component** button in the window toolbar.
- 5 In the **Materials** toolbar, click  **Add Material** to close the **Add Material** window.

MESH 1

- 1 In the **Settings** window for **Mesh**, locate the **Physics-Controlled Mesh** section.
- 2 From the **Element size** list, choose **Fine**.

Free Triangular 1

- 1 In the **Mesh** toolbar, click  **More Generators** and choose **Free Triangular**.

2 Select Boundaries 6 and 24 only.

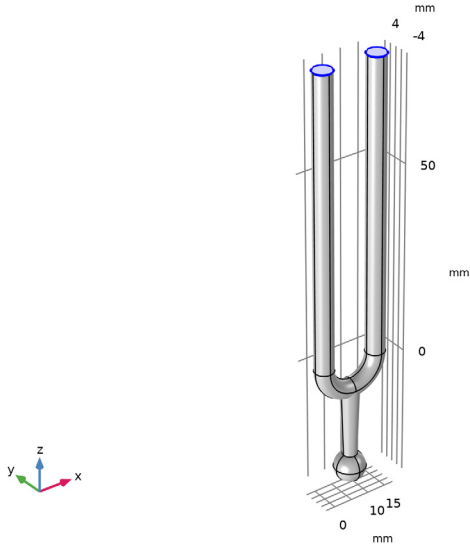

3 In the **Settings** window for **Free Triangular**, click  **Build Selected**.

Swept 1

1 In the **Mesh** toolbar, click  **Swept**.

2 In the **Settings** window for **Swept**, locate the **Domain Selection** section.

3 From the **Geometric entity level** list, choose **Domain**.

4 Select Domains 1 and 3 only.

Distribution 1

1 Right-click **Swept 1** and choose **Distribution**.

2 In the **Settings** window for **Distribution**, locate the **Distribution** section.

3 In the **Number of elements** text field, type 50.

Swept 1

In the **Model Builder** window, right-click **Swept 1** and choose **Build Selected**.

Free Tetrahedral 1

1 In the **Mesh** toolbar, click  **Free Tetrahedral**.

- In the **Model Builder** window, right-click **Mesh 1** and choose **Build All**.

The meshed geometry should look like that in the figure below.

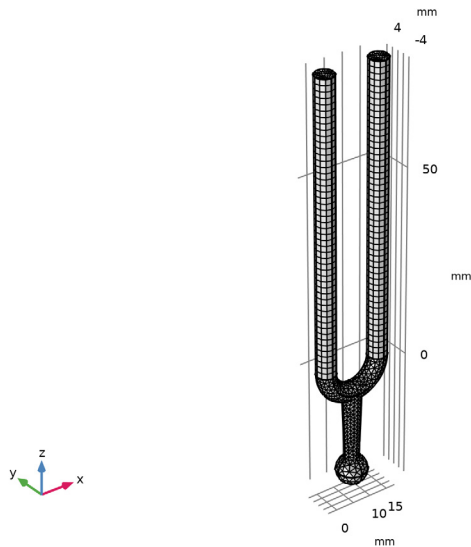

STUDY 1

Set up a parametric sweep with respect to the cylinder length L and search for an eigenfrequency in the vicinity of 440 Hz.

Parametric Sweep



- In the **Study** toolbar, click  **Parametric Sweep**.
- In the **Settings** window for **Parametric Sweep**, locate the **Study Settings** section.
- Click **+ Add**.
- In the table, enter the following settings:

Parameter name	Parameter value list
L (Cylinder length)	range(0.078, 1e-4, 0.0795)

Step 1: Eigenfrequency

- In the **Model Builder** window, click **Step 1: Eigenfrequency**.
- In the **Settings** window for **Eigenfrequency**, locate the **Study Settings** section.
- Select the **Desired number of eigenfrequencies** checkbox. In the associated text field, type 1.
- In the **Search for eigenfrequencies around shift** text field, type 440.

Solution 1 (sol1)

- 1 In the **Study** toolbar, click  **Show Default Solver**.
- 2 In the **Model Builder** window, expand the **Solution 1 (sol1)** node, then click **Eigenvalue Solver 1**.
- 3 In the **Settings** window for **Eigenvalue Solver**, locate the **General** section.
- 4 In the **Relative tolerance** text field, type $1e-3$.
- 5 In the **Study** toolbar, click  **Compute**.

RESULTS

To see all computed eigenfrequencies as a table, follow these steps:

Global Evaluation 1



- 1 In the **Results** toolbar, click  **Global Evaluation**.
- 2 In the **Settings** window for **Global Evaluation**, locate the **Data** section.
- 3 From the **Dataset** list, choose **Study 1/Parametric Solutions 1 (sol2)**.
- 4 From the **Table columns** list, choose **Inner solutions**.
- 5 Click **Replace Expression** in the upper-right corner of the **Expressions** section. From the menu, choose **Component 1 (comp1) > Solid Mechanics > Global > solid.freq - Frequency - Hz**.
- 6 Click  next to  **Evaluate**, then choose **New Table**.

TABLE 1

- 1 Go to the **Table 1** window.

You can see that the eigenfrequency closest to 440 Hz occurs for the cylinder length of 79.1 mm. Further fine-tuning can be performed if necessary.

RESULTS

To see the eigenmode that corresponds to this frequency, do the following:

Mode Shape (solid)

- 1 In the **Model Builder** window, under **Results** click **Mode Shape (solid)**.
- 2 In the **Settings** window for **3D Plot Group**, locate the **Data** section.
- 3 From the **Parameter value (L (m))** list, choose **0.0791**.
- 4 In the **Mode Shape (solid)** toolbar, click  **Plot**.

5 Click the  **Zoom Extents** button in the **Graphics** toolbar.

Lp(12)=0.0791 m Eigenfrequency=440.16 Hz Displacement magnitude (mm)
mm

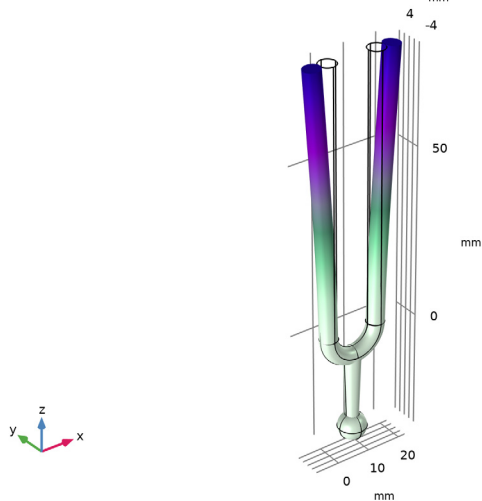

In this figure, you can clearly see that mode is symmetric, and the displacements at the handle are very small compared to those of the prongs. This means that holding the tuning fork at the handle will dampen the vibrations negligibly.