



Model created in COMSOL Multiphysics 6.4

Thin-Film Resistance

Introduction

When modeling transport by diffusion or conduction in thin layers, large differences in dimensions of the different domains are common. If the model has a sandwich structure, you can replace the thinnest layers with a thin-layer approximation, provided that the difference in thickness is large.

Model Definition

This study explains the principle of the thin-layer approximation in direct current conduction problems. A comparison of a structure with three domains to a simplified model that replaces the domain in the middle with a thin-layer approximation shows the benefit of this approach (see [Figure 1](#)).

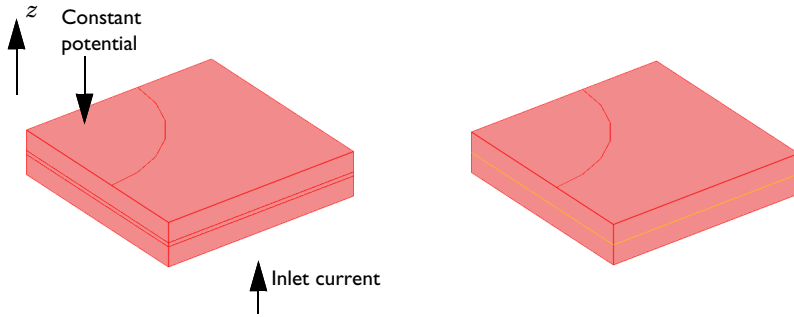

Figure 1: Exact domain description (left) and approximation (right). The current flows from the base plate to the circular plate on the upper surface of the device.

[Equation 1](#) below describes the current balance in all three domains in the real sandwich structure:

$$\nabla \cdot (-\sigma \nabla V) = 0 \quad (1)$$

In this equation, σ represents the conductivity and V the electric potential. In this case, there is a substantial difference in conductivity between the thin and thicker layers of the structure. The boundary conditions include a current inlet in the base plate of the device and a constant potential at the upper circular boundary (see [Figure 1](#)). All other boundaries are insulated.

The simplified model is based on the assumption that the components of the current density vector in the x and y directions are small and that the dominating transport

through the thin structure is obtained in the z direction. For the middle layer, this implies that you can approximate Equation 1 by the one-dimensional equation

$$-\sigma \frac{d^2 V}{dz^2} = 0 \quad (2)$$

It is possible to solve this equation analytically if the potential is given at the lower and upper surfaces of the middle layer:

$$V_{\delta=0} = V_1 \quad (3)$$

$$V_{\delta=\delta_1} = V_2 \quad (4)$$

You can integrate Equation 2 analytically to give:

$$V = az + b$$

where a and b are integration constants. If you arbitrarily place $z = 0$ at the lower boundary of the middle layer, you get the constants a and b from the boundary conditions in Equation 3 and Equation 4:

$$V_1 = b$$

$$V_2 = a\delta + b$$

This gives:

$$b = V_1$$

$$a = \frac{V_2 - V_1}{\delta}$$

The resulting equation for the potential is thus

$$V = \left(\frac{V_2 - V_1}{\delta} \right) z + V_1 \quad (5)$$

The current density is defined as

$$J_z = -\sigma \frac{dV}{dz} \quad (6)$$

Combining Equation 5 and Equation 6 gives

$$J_z = -\sigma \left(\frac{V_2 - V_1}{\delta} \right) \quad (7)$$

In the thin-film approximation the potential is discontinuous at the film boundary. Use the Contact Impedance node on interior boundaries to model a thin layer of resistive material.

It is also possible to derive the expression for the current density in [Equation 7](#) by approximating the gradient using the potential difference over the thin layer. This example includes the previous tedious derivation to show that this is exactly what you obtain from the solution of [Equation 2](#).

The approximation presented in this example is not limited to direct current problems. You can also use it for modeling of diffusion, heat conduction, flow through porous media using Darcy's law, and other types of physics that the divergence of a gradient flux describes.

In general, the application of this simplification is appropriate in cases where the differences in thickness are so large that the mesh generator cannot even mesh the domain. In some cases, the mesh generator might be able to mesh the domain but then creates a very large number of elements.

Results and Discussion

[Figure 2](#) shows a comparison between the exact solution of the problem using three conductive layers and the thin-film approximation. The comparison reveals an excellent agreement in the potential and current distribution despite that the middle film in this study is relatively thick. The approximation becomes even more accurate as the film thickness between the upper and lower domain decreases.

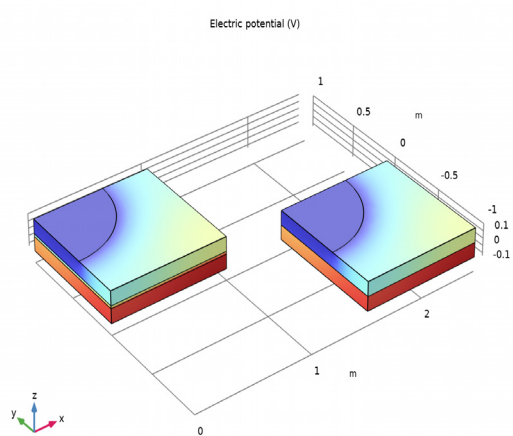

Figure 2: Potential distribution in the modeled device. The value of the potential loss over the device at a current of 0.3 A is almost identical in the two models: the full model (left) and thin-film approximation (right).

Figure 3 shows a cross-section plot of the potential through the structure's center for the full model and for the approximation. The plots show the excellent agreement obtained between the two models.

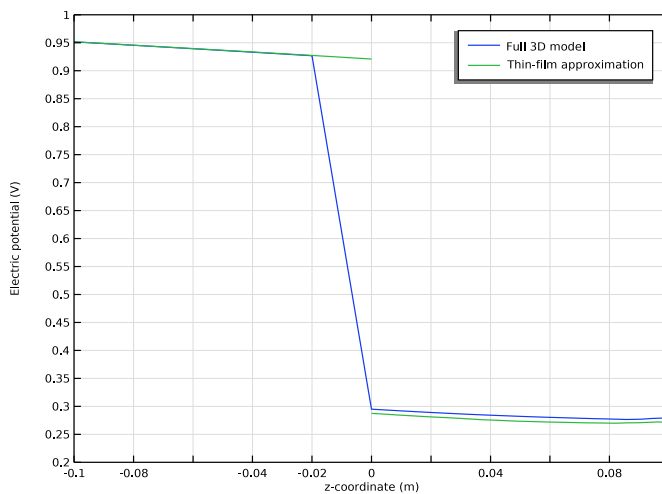



Figure 3: Potential distribution along the z direction in the middle of the device. Solution for the full model (blue line) and for the thin-film approximation (green line).

Application Library path: COMSOL_Multiphysics/Electromagnetics/
thin_film_resistance



Modeling Instructions

From the **File** menu, choose **New**.

NEW



In the **New** window, click  **Model Wizard**.

MODEL WIZARD



- 1 In the **Model Wizard** window, click  **3D**.
- 2 In the **Select Physics** tree, select **AC/DC > Electric Fields and Currents > Electric Currents (ec)**.
- 3 Click **Add**.
- 4 Click  **Study**.
- 5 In the **Select Study** tree, select **General Studies > Stationary**.
- 6 Click  **Done**.

GEOMETRY I



Work Plane 1 (wp1)

- 1 In the **Geometry** toolbar, click  **Work Plane**.
- 2 In the **Settings** window for **Work Plane**, locate the **Plane Definition** section.
- 3 In the **z-coordinate** text field, type 0.1.
- 4 Locate the **Unite Objects** section. Clear the **Unite objects** checkbox.
- 5 Click  **Go to Plane Geometry**.



Work Plane 1 (wp1) > Circle 1 (c1)

- 1 In the **Work Plane** toolbar, click  **Circle**.
- 2 In the **Settings** window for **Circle**, locate the **Size and Shape** section.
- 3 In the **Radius** text field, type 0.6.
- 4 Locate the **Position** section. In the **yw** text field, type 1.
- 5 In the **Work Plane** toolbar, click  **Build All**.



Work Plane 1 (wp1) > Square 1 (sq1)

- 1 In the **Work Plane** toolbar, click  **Square**.
- 2 Click  **Build All**.
- 3 Click the  **Zoom Extents** button in the **Graphics** toolbar.

Work Plane 1 (wp1) > Intersection 1 (int1)

- 1 In the **Work Plane** toolbar, click  **Booleans and Partitions** and choose **Intersection**.
- 2 Click in the **Graphics** window and then press Ctrl+A to select both objects.
- 3 In the **Work Plane** toolbar, click  **Build All**.

Work Plane 1 (wp1) > Square 2 (sq2)

- 1 In the **Work Plane** toolbar, click  **Square**.
- 2 Click  **Build All**.
- 3 Click the  **Zoom Extents** button in the **Graphics** toolbar.

The 2D geometry should now look as in the figure below.

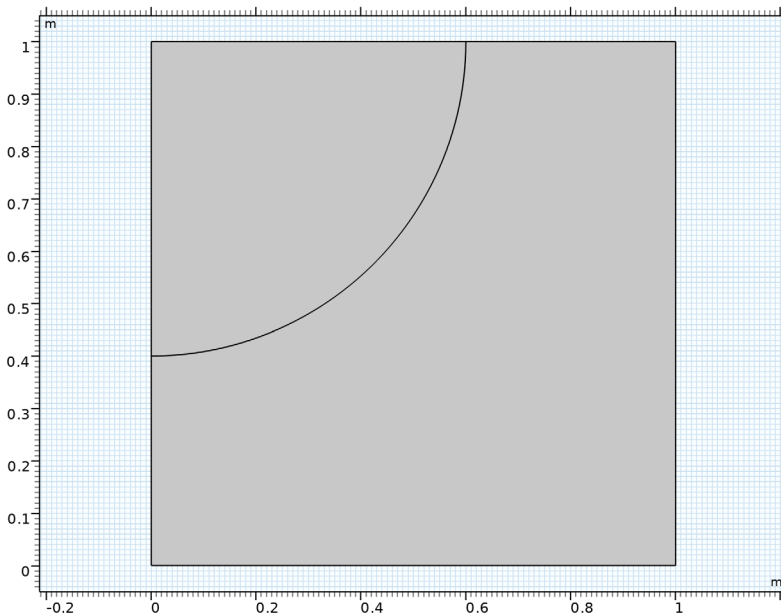

Extrude 1 (ext1)

- 1 In the **Model Builder** window, under **Component 1 (comp1) > Geometry 1** right-click **Work Plane 1 (wp1)** and choose **Extrude**.
- 2 Select the object **wp1.sq2** only.

- 3 In the **Settings** window for **Extrude**, locate the **Distances** section.
- 4 In the table, enter the following settings:

Distances (m)
-0.1

Block 1 (blk1)

- 1 In the **Geometry** toolbar, click  **Block**.
 - 2 In the **Settings** window for **Block**, locate the **Size and Shape** section.
 - 3 In the **Height** text field, type 0.1.
 - 4 Locate the **Position** section. In the **z** text field, type -0.1.
- Copy the above geometry and build the geometry for the full 3D model.



Copy 1 (copy1)

- 1 In the **Geometry** toolbar, click  **Transforms** and choose **Copy**.
- 2 Click in the **Graphics** window and then press Ctrl+A to select all objects.
- 3 In the **Settings** window for **Copy**, locate the **Displacement** section.
- 4 In the **x** text field, type 1.5.
- 5 In the **y** text field, type -1.

Move 1 (mov1)

- 1 In the **Geometry** toolbar, click  **Transforms** and choose **Move**.
- 2 Select the object **blk1** only.
- 3 In the **Settings** window for **Move**, locate the **Displacement** section.
- 4 In the **z** text field, type -0.02.

Block 2 (blk2)

- 1 In the **Geometry** toolbar, click  **Block**.
- 2 In the **Settings** window for **Block**, locate the **Size and Shape** section.
- 3 In the **Height** text field, type 0.02.
- 4 Locate the **Position** section. In the **z** text field, type -0.02.
- 5 Click  **Build All Objects**.

6 Click the  **Zoom Extents** button in the **Graphics** toolbar.

The geometry for the Thin-Film Approximation and the Full 3D model should look as in the figure below.

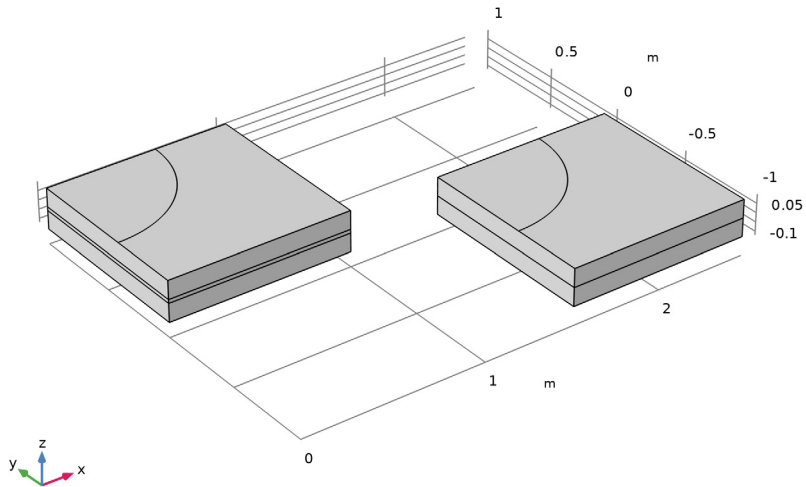

ELECTRIC CURRENTS (EC)

Current Conservation in Solids 1

- 1 In the **Model Builder** window, under **Component 1 (comp1) > Electric Currents (ec)** click **Current Conservation in Solids 1**.
- 2 In the **Settings** window for **Current Conservation in Solids**, locate the **Constitutive Relation Jc-E** section.
- 3 From the σ list, choose **User defined**. In the associated text field, type 1.
- 4 Locate the **Constitutive Relation D-E** section. From the ϵ_r list, choose **User defined**.



Normal Current Density 1

- 1 In the **Physics** toolbar, click  **Boundaries** and choose **Normal Current Density**.
- 2 Select Boundaries 3 and 20 only.
- 3 In the **Settings** window for **Normal Current Density**, locate the **Normal Current Density** section.
- 4 In the J_n text field, type 0.3.

Ground 1

- 1 In the **Physics** toolbar, click  **Boundaries** and choose **Ground**.
- 2 Select Boundaries 11 and 25 only.

Contact Impedance 1

- 1 In the **Physics** toolbar, click  **Boundaries** and choose **Contact Impedance**.
- 2 Click the  **Wireframe Rendering** button in the **Graphics** toolbar.
- 3 Select Boundary 23 only.
- 4 Click the  **Wireframe Rendering** button in the **Graphics** toolbar to restore the rendering setting.
- 5 In the **Settings** window for **Contact Impedance**, locate the **Contact Impedance** section.
- 6 In the d_s text field, type 0.02.
- 7 From the σ list, choose **User defined**. Keep the default value.
- 8 From the ϵ_r list, choose **User defined**. Again, the default value applies.

Current Conservation in Solids 2

- 1 In the **Physics** toolbar, click  **Domains** and choose **Current Conservation in Solids**.
- 2 Select Domain 2 only.
- 3 In the **Settings** window for **Current Conservation in Solids**, locate the **Constitutive Relation Jc-E** section.
- 4 From the σ list, choose **User defined**. In the associated text field, type 0.01.
- 5 Locate the **Constitutive Relation D-E** section. From the ϵ_r list, choose **User defined**.

MESH 1

- 1 In the **Model Builder** window, under **Component 1 (comp1)** click **Mesh 1**.
- 2 In the **Settings** window for **Mesh**, locate the **Physics-Controlled Mesh** section.
- 3 From the **Element size** list, choose **Coarse**.

STUDY 1

- 1 In the **Model Builder** window, click **Study 1**.
- 2 In the **Settings** window for **Study**, locate the **Study Settings** section.
- 3 Clear the **Generate default plots** checkbox, because you will add the desired plots manually.
- 4 In the **Study** toolbar, click  **Compute**.

RESULTS

The following steps show you how to reproduce the volume plot of the potential (Figure 2).

3D Plot Group 1

In the **Results** toolbar, click  **3D Plot Group**.

Volume 1

- 1 Right-click **3D Plot Group 1** and choose **Volume**.
- 2 In the **Settings** window for **Volume**, locate the **Coloring and Style** section.
- 3 Clear the **Color legend** checkbox.
- 4 From the **Color table** list, choose **RainbowLight**.
- 5 In the **3D Plot Group 1** toolbar, click  **Plot**.

Follow the steps below to visualize the potential distribution along the z direction in the middle of the device (Figure 3).

Cut Line 3D 1

- 1 In the **Results** toolbar, click  **Cut Line 3D**.
- 2 In the **Settings** window for **Cut Line 3D**, locate the **Line Data** section.
- 3 In row **Point 1**, set **x** to 0.5, **y** to 0.5, and **z** to -0.1.
- 4 In row **Point 2**, set **x** to 0.5, **y** to 0.5, and **z** to 0.1.

Cut Line 3D 2

- 1 Right-click **Cut Line 3D 1** and choose **Duplicate**.
- 2 In the **Settings** window for **Cut Line 3D**, locate the **Line Data** section.
- 3 In row **Point 1**, set **x** to 2.
- 4 In row **Point 1**, set **y** to -0.5.
- 5 In row **Point 2**, set **x** to 2.
- 6 In row **Point 2**, set **y** to -0.5.

1D Plot Group 2

- 1 In the **Results** toolbar, click  **1D Plot Group**.
- 2 In the **Settings** window for **1D Plot Group**, click to expand the **Title** section.
- 3 From the **Title type** list, choose **None**.
- 4 Locate the **Axis** section. Select the **Manual axis limits** checkbox.
- 5 In the **x minimum** text field, type -0.1.

- 6 In the **x maximum** text field, type 0.1.
- 7 In the **y minimum** text field, type 0.2.

Line Graph 1

- 1 Right-click **ID Plot Group 2** and choose **Line Graph**.
- 2 In the **Settings** window for **Line Graph**, locate the **Data** section.
- 3 From the **Dataset** list, choose **Cut Line 3D 1**.
- 4 Click **Replace Expression** in the upper-right corner of the **x-Axis Data** section. From the menu, choose **Component 1 (comp1) > Geometry > Coordinate > z - z-coordinate**.
- 5 Click to expand the **Legends** section. Select the **Show legends** checkbox.
- 6 From the **Legends** list, choose **Manual**.
- 7 In the table, enter the following settings:

Legends
Full 3D model

Line Graph 2

- 1 Right-click **Line Graph 1** and choose **Duplicate**.
- 2 In the **Settings** window for **Line Graph**, locate the **Data** section.
- 3 From the **Dataset** list, choose **Cut Line 3D 2**.
- 4 Locate the **Legends** section. In the table, enter the following settings:

Legends
Thin-film approximation

- 5 In the **ID Plot Group 2** toolbar, click  **Plot**.