



Model created in COMSOL Multiphysics 6.4

# Joule Heating of a Microactuator

## Introduction

This simple tutorial model simulates the resistive heating — also known as Joule heating — of a two-hot-arm thermal actuator. The model couples the physics phenomena involved in a single direction only. However, as explained below, you can easily modify it to simulate a bidirectional coupling between the electric current and the heating of the actuator.

## Model Definition

Figure 1 shows the actuator's parts and dimensions as well as its position on top of a substrate surface.

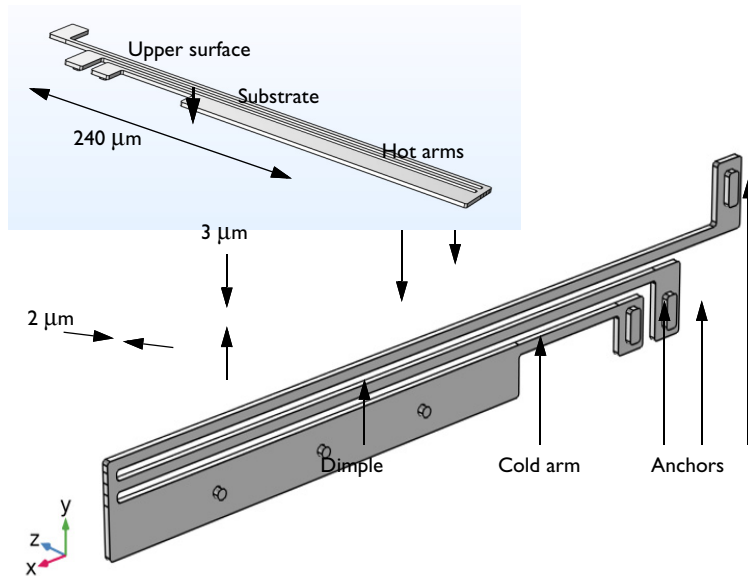

Figure 1: The thermal microactuator.

### MATERIAL DATA

This model uses the material properties listed in Table 1 for the Joule Heating Model equations. The assumption of constant material properties means that the coupling between physics phenomena is one way only: the electric current through the actuator heats up the material, but the current itself is not affected by the temperature rise. By using

a material where the electrical conductivity is temperature dependent, you can turn this into a bidirectional coupling.

TABLE I: MATERIAL DATA.

PROPERTY	NAME	VALUE
Electrical conductivity	$\sigma$	$5 \cdot 10^4$ S/m
Relative permeability	$\epsilon_r$	4.5
Thermal conductivity	$k$	40 W/(m·K)
Density	$\rho$	2300 kg/m <sup>3</sup>
Heat capacity at constant pressure	$C_p$	600 J/(kg·K)

### BOUNDARY CONDITIONS

An electric potential is applied between the bases of the hot arms' anchors. The cold arm anchor and all other surfaces are electrically insulated.

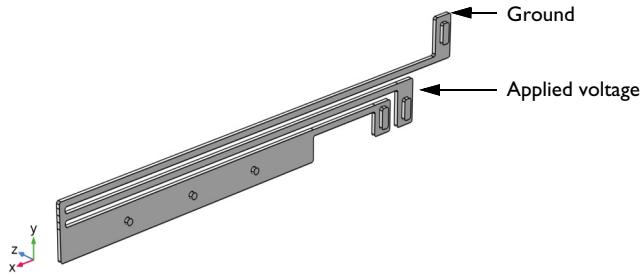
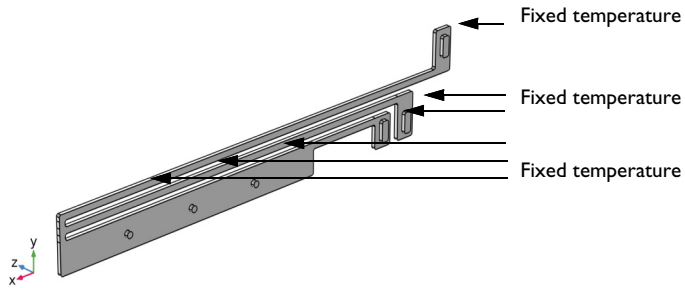

Figure 2: Electrical boundary conditions.

The temperature of the base of the three anchors and the three dimples is fixed to that of the substrate's constant temperature. Because the structure is sandwiched, all other boundaries interact thermally with the surroundings by conduction through thin layers of air.

The heat transfer coefficient is given by the thermal conductivity of air divided by the distance to the surrounding surfaces for the system. This exercise uses different heat transfer coefficients for the actuator's upper and other surfaces.

$$\text{Heat flux}_{\perp} = h(T - T_{\text{amb}})$$



*Figure 3: Heat-transfer boundary conditions.*

## *Results*

---

Figure 4 shows the temperature distribution on the actuator's surface. The line graph in Figure 5 provides more detailed information about the temperature along a single edge facing the substrate plane.

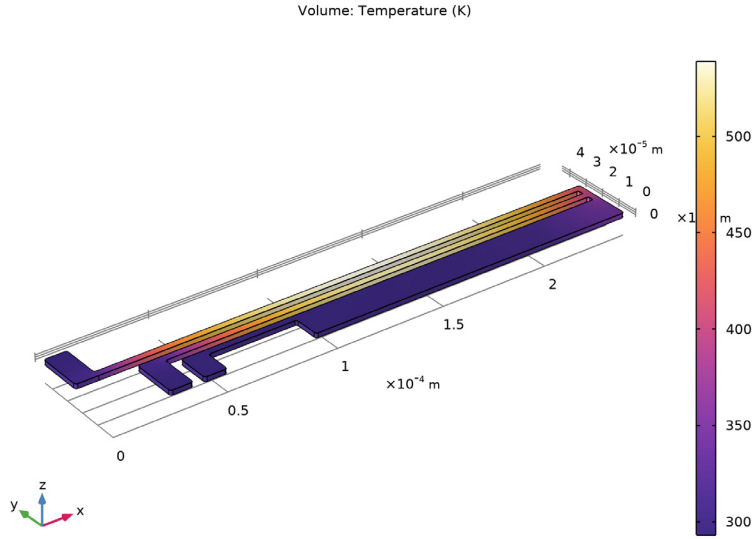

Figure 4: The temperature distribution on the actuator surface.

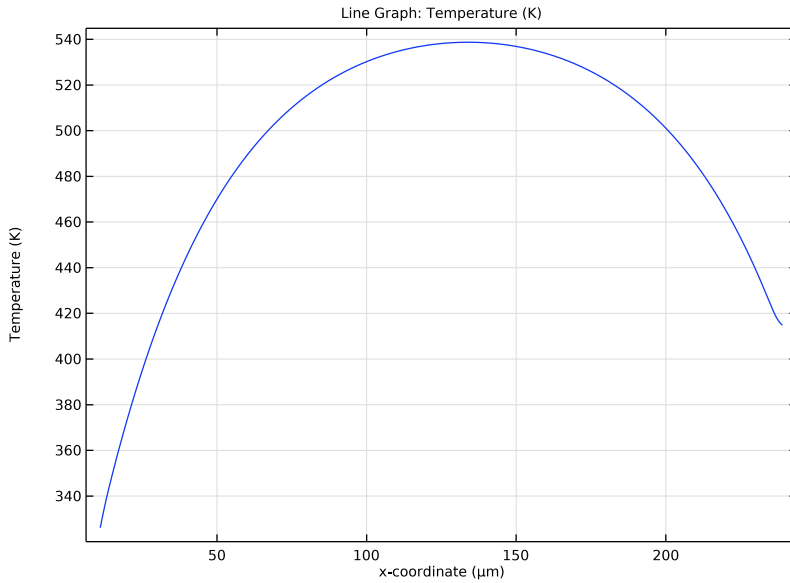

Figure 5: Temperature along the actuators longest edge facing the substrate.

---

**Application Library path:** COMSOL\_Multiphysics/Multiphysics/  
thermal\_actuator\_jh

---

### *Modeling Instructions*



---

From the **File** menu, choose **New**.

#### **NEW**

In the **New** window, click  **Model Wizard**.

#### **MODEL WIZARD**

- 1 In the **Model Wizard** window, click  **3D**.
- 2 In the **Select Physics** tree, select **Heat Transfer > Electromagnetic Heating > Joule Heating**.
- 3 Click **Add**.
- 4 Click  **Study**.
- 5 In the **Select Study** tree, select **General Studies > Stationary**.
- 6 Click  **Done**.

#### **THERMAL ACTUATOR**

- 1 In the **Model Builder** window, right-click **Component 1 (comp1)** and choose **Rename**.
- 2 In the **Rename Component** dialog, type Thermal Actuator in the **New label** text field.
- 3 Click **OK**.

#### **GLOBAL DEFINITIONS**

##### *Parameters 1*





- 1 In the **Model Builder** window, under **Global Definitions** click **Parameters 1**.
- 2 In the **Settings** window for **Parameters**, locate the **Parameters** section.

3 In the table, enter the following settings:

Name	Expression	Value	Description
htc_s	$0.04[W/(m^2K)]/2[\mu m]$	20000 W/(m <sup>2</sup> ·K)	Heat transfer coefficient
htc_us	$0.04[W/(m^2K)]/100[\mu m]$	400 W/(m <sup>2</sup> ·K)	Heat transfer coefficient, upper surface
DV	5[V]	5 V	Applied voltage

## GEOMETRY I

### Import I (impl)

- 1 In the **Geometry** toolbar, click  **Import**.
- 2 In the **Settings** window for **Import**, locate the **Source** section.
- 3 Click  **Browse**.
- 4 Browse to the model's Application Libraries folder and double-click the file thermal\_actuator.mphbin.
- 5 Click  **Build All Objects**.
- 6 Click the  **Zoom Extents** button in the **Graphics** toolbar.

## DEFINITIONS

### Substrate Contact

- 1 In the **Definitions** toolbar, click  **Explicit**.
- 2 In the **Settings** window for **Explicit**, type Substrate Contact in the **Label** text field.
- 3 Locate the **Input Entities** section. From the **Geometric entity level** list, choose **Boundary**.
- 4 Select Boundaries 10, 30, 50, 70, 76, and 82 only.

## MATERIALS

### Material I (matI)

- 1 In the **Model Builder** window, under **Thermal Actuator (comp I)** right-click **Materials** and choose **Blank Material**.  
By default, the first material you define applies to all domains.
- 2 In the **Settings** window for **Material**, locate the **Material Contents** section.

3 In the table, enter the following settings:

Property	Variable	Value	Unit	Property group
Electric conductivity	sigma_iso ; sigma_ii = sigma_iso, sigma_ij = 0	5e4	S/m	Basic
Relative permittivity	epsilon_r_iso ; epsilon_rii = epsilon_r_iso, epsilon_r_ij = 0	4.5	1	Basic
Thermal conductivity	k_iso ; k_ii = k_iso, k_ij = 0	40	W/(m·K)	Basic
Density	rho	2.3e3	kg/m <sup>3</sup>	Basic
Heat capacity at constant pressure	Cp	600	J/(kg·K)	Basic

### ELECTRIC CURRENTS (EC)

#### Ground I

- 1 In the **Physics** toolbar, click  **Boundaries** and choose **Ground**.
- 2 Select Boundary 10 only.

#### Electric Potential I

- 1 In the **Physics** toolbar, click  **Boundaries** and choose **Electric Potential**.
- 2 Select Boundary 30 only.
- 3 In the **Settings** window for **Electric Potential**, locate the **Electric Potential** section.
- 4 In the  $V_0$  text field, type DV.

### HEAT TRANSFER IN SOLIDS (HT)

#### Heat Flux I

- 1 In the **Physics** toolbar, click  **Boundaries** and choose **Heat Flux**.

This boundary condition applies to all boundaries except the top-surface boundary and those in contact with the substrate. A **Temperature** condition on the `substrate_contact` boundaries will override this **Heat Flux** condition so you do not explicitly need to exclude those boundaries. In contrast, because the **Heat Flux** boundary condition is additive, you must explicitly exclude the top-surface boundary from the selection. Implement this selection as follows:

- 2 In the **Settings** window for **Heat Flux**, locate the **Boundary Selection** section.
- 3 From the **Selection** list, choose **All boundaries**.
- 4 In the **Graphics** window, click on the top surface and then right-click to remove it from the selection.

A convective heat flux is used to model the heat flux through a thin air layer. The heat transfer coefficient,  $h_{tc\_s}$  is defined as the ratio of the air thermal conductivity to the gap thickness.

- 5 Locate the **Heat Flux** section. From the **Flux type** list, choose **Convective heat flux**.
- 6 In the  $h$  text field, type  $h_{tc\_s}$ .

#### *Heat Flux 2*

- 1 In the **Physics** toolbar, click  **Boundaries** and choose **Heat Flux**.
- 2 Select Boundary 4 only.

A convective heat flux is used to model the heat flux through a thin air layer. The heat transfer coefficient,  $h_{tc\_us}$  is defined as the ratio of the air thermal conductivity to the gap thickness.

- 3 In the **Settings** window for **Heat Flux**, locate the **Heat Flux** section.
- 4 From the **Flux type** list, choose **Convective heat flux**.
- 5 In the  $h$  text field, type  $h_{tc\_us}$ .



#### *Temperature 1*

- 1 In the **Physics** toolbar, click  **Boundaries** and choose **Temperature**.
- 2 In the **Settings** window for **Temperature**, locate the **Boundary Selection** section.
- 3 From the **Selection** list, choose **Substrate Contact**.

#### **MESH 1**

- 1 In the **Model Builder** window, under **Thermal Actuator (comp1)** click **Mesh 1**.
- 2 In the **Settings** window for **Mesh**, locate the **Physics-Controlled Mesh** section.
- 3 From the **Element size** list, choose **Fine**.

#### *Free Triangular 1*

- 1 In the **Mesh** toolbar, click  **More Generators** and choose **Free Triangular**.
- 2 In the **Settings** window for **Free Triangular**, locate the **Boundary Selection** section.
- 3 From the **Selection** list, choose **Substrate Contact**.
- 4 Click  **Paste Selection**.
- 5 In the **Paste Selection** dialog, type 3 in the **Selection** text field.

6 Click **OK**.

7 In the **Settings** window for **Free Triangular**, click  **Build Selected**.

*Swept 1*

1 In the **Mesh** toolbar, click  **Swept**.

2 In the **Model Builder** window, right-click **Mesh 1** and choose **Build All**.

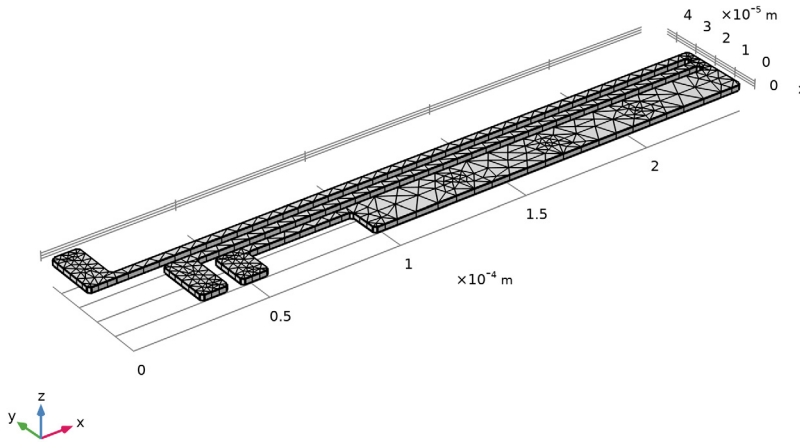

## STUDY 1

In the **Study** toolbar, click  **Compute**.

## RESULTS

*Electric Potential (ec)*

The first default plot group shows the electric potential distribution.

*Temperature (ht)*

The second default plot group shows the temperature distribution on the surface (see [Figure 4](#)).

1 Click the  **Zoom Extents** button in the **Graphics** toolbar.

Reproduce the plot in [Figure 5](#) by following these steps:

### *ID Plot Group 4*

In the **Results** toolbar, click  **ID Plot Group**.

### *Line Graph 1*

- 1** Right-click **ID Plot Group 4** and choose **Line Graph**.
- 2** Select Edge 52 only.
- 3** In the **Settings** window for **Line Graph**, click **Replace Expression** in the upper-right corner of the **y-Axis Data** section. From the menu, choose **Thermal Actuator (comp1) > Heat Transfer in Solids > Temperature > T - Temperature - K**.
- 4** Click **Replace Expression** in the upper-right corner of the **x-Axis Data** section. From the menu, choose **Thermal Actuator (comp1) > Geometry > Coordinate > x - x-coordinate**.
- 5** Locate the **x-Axis Data** section. From the **Unit** list, choose **µm**.
- 6** In the **ID Plot Group 4** toolbar, click  **Plot**.

