



Model created in COMSOL Multiphysics 6.4

Submodeling Analysis of a Shaft

Introduction

Submodeling can be used when it is not possible to resolve all details of a complex geometry in a full model.

You can cope with this type of problems with a technique known as *submodeling*. First, you solve the full model with a mesh which is sufficient to capture the stiffness of the structure. In a second analysis, you create a local model (submodel) of the region around the stress concentration with a fine mesh, and solve it using the displacements from the full model as boundary conditions.

There are some underlying assumptions when using submodels:

- The full model is accurate enough to give correct displacements on the boundary to the submodel.
- The improvements introduced in the submodel are so small that they do not introduce significant changes in stiffness on the global level. Given this, it could still be possible to introduce a nonlinear material locally in the submodel.

In this example, this technique is applied to perform an accurate stress evaluation in a structural mechanics model, but the same approach is applicable to problems in many different fields of physics. The example geometry as such is not so complicated, so there is nothing to gain from a submodeling in this case. The purpose of the example is only to introduce the technique.

Model Definition

The geometry consists of a shaft with a sudden change in diameter. At the location of the diameter change, there is a fillet with a small radius. In the fillet, stress concentrations will appear. There is also a central hole through the shaft. The geometry and mesh are shown in [Figure 1](#).

The shaft is fixed at the thick end. On the thin end, a tensile force of 2500 N and a shear force of 900 N are applied.

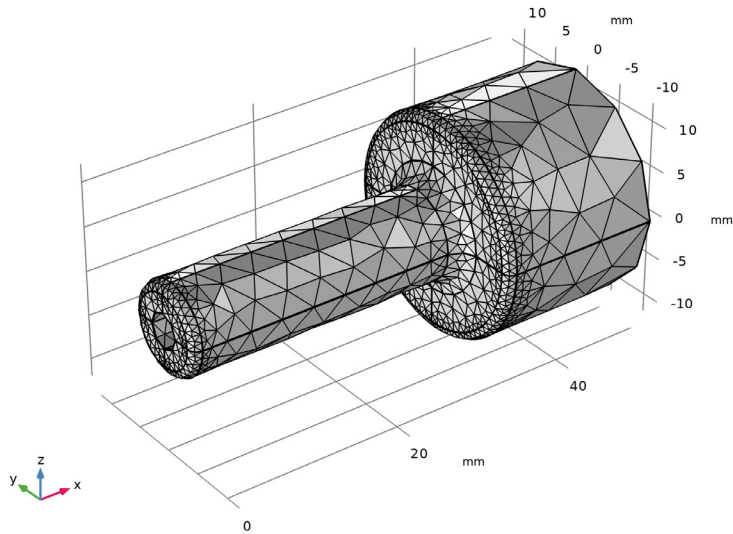

Figure 1: The geometry and mesh of the full model.

As submodel, a region around the fillet at the side giving the highest stress is chosen. The cuts where the boundary conditions are applied on the submodel should preferably be placed at locations where the stress field is fairly smooth.

The geometry and mesh of the submodel are shown in [Figure 2](#). As can be seen, the fillet has a good mesh resolution since the purpose is to obtain results with high accuracy there.

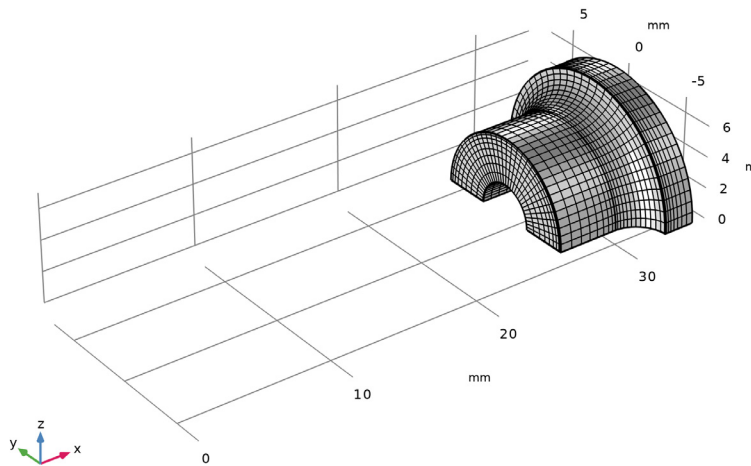

Figure 2: The geometry and mesh of the submodel.

In this example, it would be possible to reduce both the full model and the submodel even further by making use of the fact that the xz -plane is a symmetry plane.

The material is steel, with Young's modulus 200 GPa and Poisson's ratio 0.3.

Results

The general stress distribution is shown in [Figure 3](#). Since the load is unsymmetrical (there is both an axial and a bending component), the highest stress occurs at the side with positive Z coordinate.

The cut through the model in [Figure 4](#) displays that the stresses are not well resolved. There are significant jumps between the neighboring elements.

In the corresponding figures from the submodel, [Figure 5](#) and [Figure 6](#), the stress field is smooth and well resolved.

The computed peak stresses for the two models do not differ that much, but that is more of a lucky coincidence, considering the lack of continuity in the stress field.

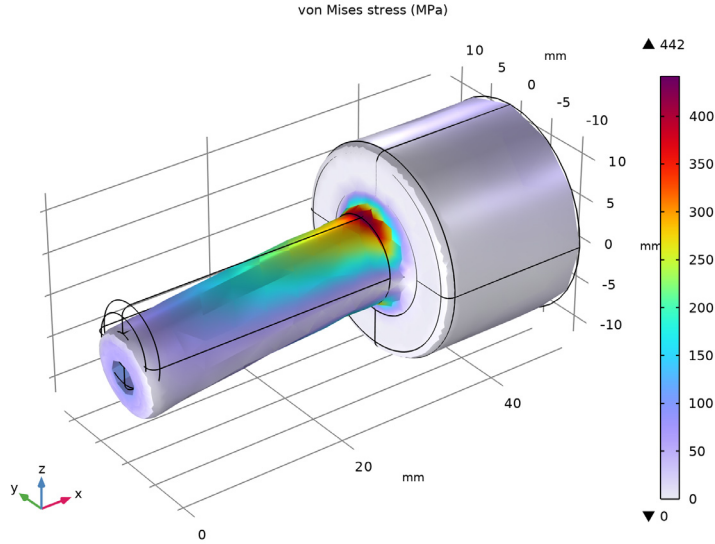

Figure 3: Stress distribution in the full model.

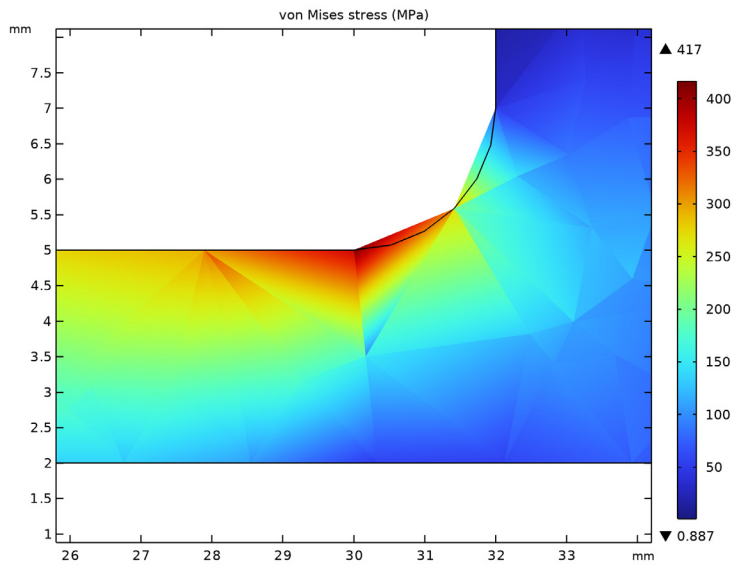

Figure 4: Stress in the full model (cut view).

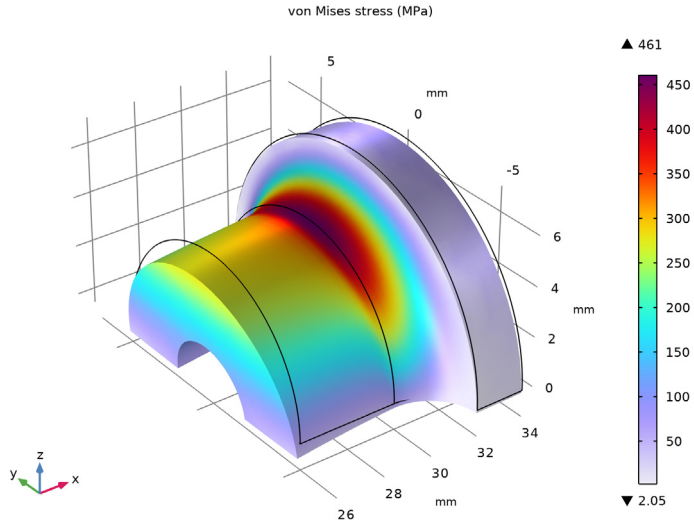

Figure 5: Stress distribution in the submodel.

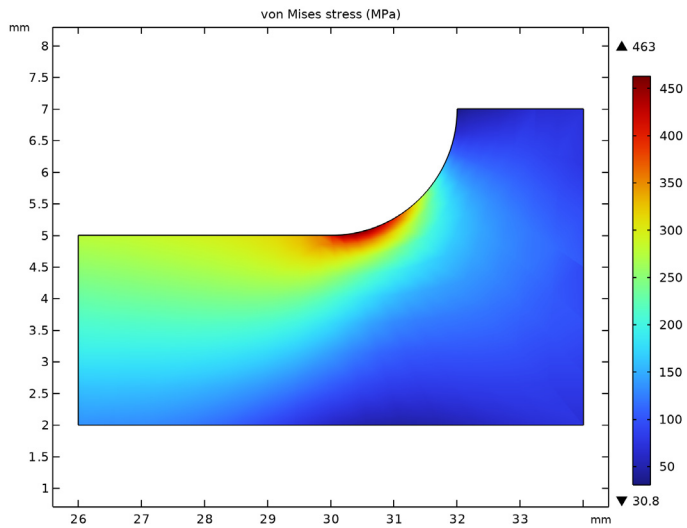

Figure 6: Stress in the submodel (cut view).

As a verification, it is a good habit to always compare the stress state at the cuts where the submodel has displacements prescribed with the results in the full model. Such a comparison is shown in Figure 7. The results have an almost perfect match, which indicates that the submodel has been set up correctly.

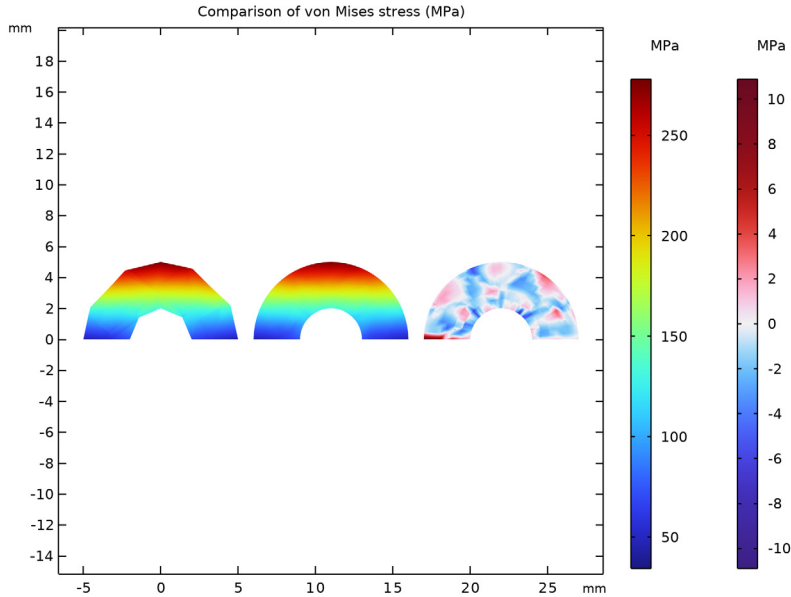

Figure 7: Stress distribution over one of the cuts. Full model (left), submodel (center), and their difference (right) are shown. Note the separate color bar for the difference.

Notes About the COMSOL Implementation

Two different components are used within the same mph file. In the full model, a general extrusion feature is introduced in order to describe the mapping of results from the full model to the submodel. The prescribed displacements on the cut boundaries in the submodel reference the displacements in the full model through this mapping.

In this example, there are no volume forces. If there were, such forces must be applied also on the submodel.

In the example *Submodeling with Plasticity* (available with the Nonlinear Structural Materials module), the current analysis is extended so that local plasticity in the fillet is taken into account.

Application Library path: COMSOL_Multiphysics/Structural_Mechanics/
shaft_submodeling



Modeling Instructions

From the **File** menu, choose **New**.

NEW

In the **New** window, click  **Model Wizard**.

MODEL WIZARD

- 1 In the **Model Wizard** window, click  **3D**.
- 2 In the **Select Physics** tree, select **Structural Mechanics > Solid Mechanics (solid)**.
- 3 Click **Add**.
- 4 Click  **Study**.
- 5 In the **Select Study** tree, select **General Studies > Stationary**.
- 6 Click  **Done**.

FULL GEOMETRY

- 1 In the **Model Builder** window, right-click **Global Definitions** and choose **Geometry Parts > 3D Part**.

Create the geometry. To simplify this step, insert a prepared geometry sequence.

- 2 In the **Settings** window for **Part**, locate the **Units** section.
- 3 From the **Length unit** list, choose **mm**.
- 4 In the **Geometry** toolbar, click **Insert Sequence** and choose **Insert Sequence**.
- 5 Browse to the model's Application Libraries folder and double-click the file `shaft_submodeling_geom_sequence.mph`.
- 6 In the **Geometry** toolbar, click  **Build All**.
- 7 In the **Label** text field, type Full Geometry.



FULL MODEL

- 1 In the **Model Builder** window, click **Component 1 (comp1)**.
- 2 In the **Settings** window for **Component**, type Full Model in the **Label** text field.

GEOMETRY I

- 1 In the **Model Builder** window, under **Full Model (comp1)** click **Geometry I**.
- 2 In the **Settings** window for **Geometry**, locate the **Units** section.
- 3 From the **Length unit** list, choose **mm**.



Full Geometry I (pl)

- 1 In the **Geometry** toolbar, click  **Part Instance** and choose **Full Geometry**.
- 2 In the **Settings** window for **Part Instance**, click  **Build All Objects**.
- 3 Click to expand the **Boundary Selections** section. In the table, enter the following settings:

Name	Keep	Physics	Contribute to
Boundary Load	√	√	None
Fixed Constrained	√	√	None

The geometry sequence contains two selections, these will be used later to apply loads and constraints.

ADD MATERIAL

- 1 In the **Materials** toolbar, click  **Add Material** to open the **Add Material** window.
- 2 Go to the **Add Material** window.
- 3 In the tree, select **Built-in > Structural steel**.
- 4 Right-click and choose **Add to Global Materials**.
- 5 In the **Materials** toolbar, click  **Add Material** to close the **Add Material** window.

The material is now defined as global material so that both the full model and the submodel can use the same material definition, defined at one location only in the model tree.

MATERIALS

Material Link 1 (matlnk1)

In the **Model Builder** window, under **Full Model (comp1)** right-click **Materials** and choose **More Materials > Material Link**.

SOLID MECHANICS (SOLID)

Fixed Constraint 1

- 1 In the **Physics** toolbar, click  **Boundaries** and choose **Fixed Constraint**.



- 2 In the **Settings** window for **Fixed Constraint**, locate the **Boundary Selection** section.
- 3 From the **Selection** list, choose **Fixed Constrained (Full Geometry 1)**.

Boundary Load 1

- 1 In the **Physics** toolbar, click  **Boundaries** and choose **Boundary Load**.
- 2 In the **Settings** window for **Boundary Load**, locate the **Boundary Selection** section.
- 3 From the **Selection** list, choose **Boundary Load (Full Geometry 1)**.
- 4 Locate the **Force** section. From the **Load type** list, choose **Total force**.
- 5 Specify the \mathbf{F}_{tot} vector as

-2.5 [kN]	x
0	y
-0.9 [kN]	z

MESH 1

- 1 In the **Model Builder** window, under **Full Model (comp1)** click **Mesh 1**.
- 2 In the **Settings** window for **Mesh**, locate the **Physics-Controlled Mesh** section.
- 3 From the **Element size** list, choose **Extra coarse**.
- 4 Click  **Build All**.
- 5 Click the  **Zoom Extents** button in the **Graphics** toolbar.

FULL MODEL

- 1 In the **Model Builder** window, click **Study 1**.
- 2 In the **Settings** window for **Study**, type Full Model in the **Label** text field.
- 3 In the **Study** toolbar, click  **Compute**.



RESULTS

Stress - Full Model

- 1 In the **Settings** window for **3D Plot Group**, type Stress - Full Model in the **Label** text field.
- 2 Locate the **Color Legend** section. Select the **Show maximum and minimum values** checkbox.

Volume 1

- 1 In the **Model Builder** window, expand the **Stress - Full Model** node, then click **Volume 1**.
- 2 In the **Settings** window for **Volume**, click to expand the **Quality** section.

- 3 Locate the **Expression** section. From the **Unit** list, choose **MPa**.
- 4 Locate the **Quality** section. From the **Resolution** list, choose **No refinement**.
- 5 From the **Smoothing** list, choose **None**.
- 6 In the **Stress - Full Model** toolbar, click  **Plot**.
- 7 Click the  **Zoom Extents** button in the **Graphics** toolbar.

Cut Plane 1

- 1 In the **Model Builder** window, expand the **Results > Datasets** node.
- 2 Right-click **Results > Datasets** and choose **Cut Plane**.
- 3 In the **Settings** window for **Cut Plane**, locate the **Plane Data** section.
- 4 From the **Plane** list, choose **XZ-planes**.

Cut Plane Stress - Full Model

- 1 In the **Results** toolbar, click  **2D Plot Group**.
- 2 In the **Settings** window for **2D Plot Group**, type Cut Plane Stress - Full Model in the **Label** text field.
- 3 Locate the **Color Legend** section. Select the **Show maximum and minimum values** checkbox.

Surface 1

- 1 Right-click **Cut Plane Stress - Full Model** and choose **Surface**.
- 2 In the **Settings** window for **Surface**, locate the **Expression** section.
- 3 In the **Expression** text field, type `solid.mises`.
- 4 From the **Unit** list, choose **MPa**.
- 5 Click to expand the **Quality** section. From the **Evaluation settings** list, choose **Manual**.
- 6 From the **Resolution** list, choose **No refinement**.
- 7 From the **Smoothing** list, choose **None**.
- 8 In the **Cut Plane Stress - Full Model** toolbar, click  **Plot**.

ADD COMPONENT

In the **Model Builder** window, right-click the root node and choose **Add Component > 3D**.

SUBMODEL

In the **Settings** window for **Component**, type `Submodel` in the **Label** text field.

SUBMODEL CUT

- 1 In the **Model Builder** window, under **Global Definitions** right-click **Geometry Parts** and choose **3D Part**.
- 2 In the **Settings** window for **Part**, type Submodel Cut in the **Label** text field.
- 3 Locate the **Units** section. From the **Length unit** list, choose **mm**.

Cylinder 1 (cyl1)

- 1 In the **Geometry** toolbar, click  **Cylinder**.
- 2 In the **Settings** window for **Cylinder**, locate the **Size and Shape** section.
- 3 In the **Radius** text field, type 7.
- 4 In the **Height** text field, type 8.
- 5 Locate the **Position** section. In the **x** text field, type 26.
- 6 Locate the **Axis** section. From the **Axis type** list, choose **x-axis**.

Block 1 (blk1)

- 1 In the **Geometry** toolbar, click  **Block**.
- 2 In the **Settings** window for **Block**, locate the **Size and Shape** section.
- 3 In the **Width** text field, type 10.
- 4 In the **Depth** text field, type 14.
- 5 In the **Height** text field, type 10.
- 6 Locate the **Position** section. In the **x** text field, type 26.
- 7 In the **y** text field, type -7.

Submodel Cut

- 1 In the **Geometry** toolbar, click  **Booleans and Partitions** and choose **Intersection**.
- 2 In the **Settings** window for **Intersection**, type Submodel Cut in the **Label** text field.
- 3 Click in the **Graphics** window and then press Ctrl+A to select both objects.
- 4 Locate the **Selections of Resulting Entities** section. Select the **Resulting objects selection** checkbox.
- 5 From the **Show in instances** list, choose **Boundary selection**.

GEOMETRY 2

- 1 In the **Model Builder** window, under **Submodel (comp2)** click **Geometry 2**.
- 2 In the **Settings** window for **Geometry**, locate the **Units** section.
- 3 From the **Length unit** list, choose **mm**.

Full Geometry I (pi1)

In the **Geometry** toolbar, click  **Part Instance** and choose **Full Geometry**.

Submodel Cut I (pi2)

1 In the **Geometry** toolbar, click  **Part Instance** and choose **Submodel Cut**.

2 In the **Settings** window for **Part Instance**, click  **Build Selected**.

3 Locate the **Boundary Selections** section. In the table, enter the following settings:

Name	Keep	Physics	Contribute to
Submodel Cut	√	√	None

Intersection I (int1)

1 In the **Geometry** toolbar, click  **Booleans and Partitions** and choose **Intersection**.

2 Click in the **Graphics** window and then press Ctrl+A to select both objects.

3 In the **Settings** window for **Intersection**, click  **Build All Objects**.

The submodel geometry is now built. In order to create a structured mesh, you need to partition the geometry following the xz-plane.

Work Plane I (wp1)

1 In the **Geometry** toolbar, click  **Work Plane**.

2 In the **Settings** window for **Work Plane**, locate the **Plane Definition** section.

3 From the **Plane** list, choose **zx-plane**.

Partition Objects I (par1)

1 In the **Geometry** toolbar, click  **Booleans and Partitions** and choose **Partition Objects**.

2 Select the object **int1** only.

3 In the **Settings** window for **Partition Objects**, locate the **Partition Objects** section.

4 From the **Partition with** list, choose **Work plane**.

Mesh Control Domains I (mcd1)

1 In the **Geometry** toolbar, click  **Virtual Operations** and choose **Mesh Control Domains**.

2 On the object **fin**, select Domains 1 and 2 only.

3 In the **Geometry** toolbar, click  **Build All**.

4 Click the  **Zoom Extents** button in the **Graphics** toolbar.

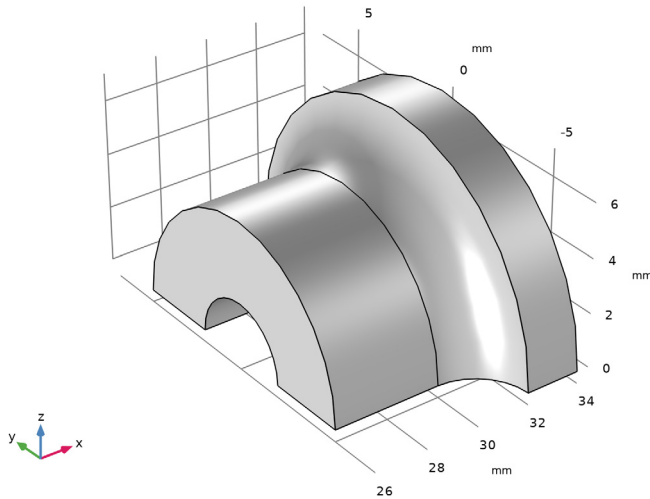



MATERIALS

Material Link 2 (matlnk2)

In the **Model Builder** window, under **Submodel (comp2)** right-click **Materials** and choose **More Materials > Material Link**.

ADD PHYSICS

- 1 In the **Home** toolbar, click  **Add Physics** to open the **Add Physics** window.
- 2 Go to the **Add Physics** window.
- 3 In the tree, select **Structural Mechanics > Solid Mechanics (solid)**.
- 4 Click the **Add to Submodel** button in the window toolbar.
- 5 In the **Home** toolbar, click  **Add Physics** to close the **Add Physics** window.

DEFINITIONS (COMP1)

In the **Model Builder** window, under **Full Model (comp1)** click **Definitions**.

General Extrusion 1 (genext1)

- 1 In the **Definitions** toolbar, click  **Nonlocal Couplings** and choose **General Extrusion**.
- 2 Select Domain 1 only.
- 3 In the **Settings** window for **General Extrusion**, locate the **Destination Map** section.

- 4 In the **x-expression** text field, type X.
- 5 In the **y-expression** text field, type Y.
- 6 In the **z-expression** text field, type Z.
- 7 Locate the **Source** section. From the **Source frame** list, choose **Material (X, Y, Z)**.
You have now created the nonlocal coupling which will be used for mapping the solution from the full model to the submodel.

SOLID MECHANICS 2 (SOLID2)

In the **Model Builder** window, under **Submodel (comp2)** click **Solid Mechanics 2 (solid2)**.

Prescribed Displacement 1

- 1 In the **Physics** toolbar, click  **Boundaries** and choose **Prescribed Displacement**.
- 2 In the **Settings** window for **Prescribed Displacement**, locate the **Boundary Selection** section.
- 3 From the **Selection** list, choose **Submodel Cut (Submodel Cut 1)**.
- 4 Locate the **Prescribed Displacement** section. From the **Displacement in x direction** list, choose **Prescribed**.
- 5 In the u_{0x} text field, type `comp1.genext1(comp1.u)`.
- 6 From the **Displacement in y direction** list, choose **Prescribed**.
- 7 In the u_{0y} text field, type `comp1.genext1(comp1.v)`.
- 8 From the **Displacement in z direction** list, choose **Prescribed**.
- 9 In the u_{0z} text field, type `comp1.genext1(comp1.w)`.

MESH 2

Mapped 1

- 1 In the **Mesh** toolbar, click  **More Generators** and choose **Mapped**.
- 2 Select Boundary 2 only.

Distribution 1

- 1 Right-click **Mapped 1** and choose **Distribution**.
- 2 Select Edges 1 and 3 only.
- 3 In the **Settings** window for **Distribution**, locate the **Distribution** section.
- 4 From the **Distribution type** list, choose **Predefined**.
- 5 In the **Number of elements** text field, type 8.
- 6 In the **Element ratio** text field, type 4.

7 Select the **Reverse direction** checkbox.

Distribution 2

1 In the **Model Builder** window, right-click **Mapped 1** and choose **Distribution**.

2 Select Edge 13 only.

3 In the **Settings** window for **Distribution**, locate the **Distribution** section.

4 From the **Distribution type** list, choose **Predefined**.

5 In the **Number of elements** text field, type 8.

6 In the **Element ratio** text field, type 4.

Distribution 3

1 Right-click **Mapped 1** and choose **Distribution**.

2 Select Edge 15 only.

3 In the **Settings** window for **Distribution**, locate the **Distribution** section.

4 In the **Number of elements** text field, type 6.

Distribution 4

1 Right-click **Mapped 1** and choose **Distribution**.

2 Select Edge 10 only.

3 In the **Settings** window for **Distribution**, locate the **Distribution** section.

4 From the **Distribution type** list, choose **Predefined**.

5 In the **Number of elements** text field, type 12.

6 In the **Element ratio** text field, type 2.

Swept 1

1 In the **Mesh** toolbar, click  **Swept**.

2 In the **Settings** window for **Swept**, click to expand the **Control Entities** section.

3 From the **Smooth across removed control entities** list, choose **Off**.

Distribution 1

1 Right-click **Swept 1** and choose **Distribution**.



2 In the **Settings** window for **Distribution**, locate the **Distribution** section.

3 In the **Number of elements** text field, type 16.

4 Click  **Build All**.

5 In the **Model Builder** window, right-click **Mesh 2** and choose **Build All**.

ADD STUDY

- 1 In the **Home** toolbar, click  **Add Study** to open the **Add Study** window.
- 2 Go to the **Add Study** window.
- 3 Find the **Studies** subsection. In the **Select Study** tree, select **General Studies > Stationary**.
- 4 Find the **Physics interfaces in study** subsection. In the table, clear the **Solve** checkbox for **Solid Mechanics (solid)**.
- 5 Click the **Add Study** button in the window toolbar.
- 6 In the **Home** toolbar, click  **Add Study** to close the **Add Study** window.

SUBMODEL



In the **Settings** window for **Study**, type Submodel in the **Label** text field.

Step 1: Stationary

- 1 In the **Model Builder** window, under **Submodel** click **Step 1: Stationary**.
- 2 In the **Settings** window for **Stationary**, click to expand the **Values of Dependent Variables** section.
- 3 Find the **Values of variables not solved for** subsection. From the **Settings** list, choose **User controlled**.
- 4 From the **Method** list, choose **Solution**.
- 5 From the **Study** list, choose **Full Model, Stationary**.
- 6 In the **Study** toolbar, click  **Compute**.

RESULTS

Preferred Units 1

- 1 In the **Results** toolbar, click  **Configurations** and choose **Preferred Units**.
- 2 In the **Settings** window for **Preferred Units**, locate the **Units** section.
- 3 Click  **Add Physical Quantity**.
- 4 In the **Physical Quantity** dialog, select **Solid Mechanics > Stress tensor (N/m²)** in the tree.
- 5 Click **OK**.
- 6 In the **Settings** window for **Preferred Units**, locate the **Units** section.
- 7 In the table, enter the following settings:



Quantity	Unit	Preferred unit
Stress tensor	N/m ²	MPa

- 8 Select the **Apply conversions to expressions with the same dimensions** checkbox.

Stress - Submodel

- 1 In the **Model Builder** window, under **Results** click **Stress (solid2)**.
- 2 In the **Settings** window for **3D Plot Group**, type **Stress - Submodel** in the **Label** text field.
- 3 Locate the **Color Legend** section. Select the **Show maximum and minimum values** checkbox.

Volume 1

- 1 In the **Model Builder** window, expand the **Stress - Submodel** node, then click **Volume 1**.
- 2 In the **Settings** window for **Volume**, locate the **Expression** section.
- 3 From the **Unit** list, choose **MPa**.
- 4 Locate the **Quality** section. From the **Resolution** list, choose **No refinement**.
- 5 From the **Smoothing** list, choose **None**.
- 6 In the **Stress - Submodel** toolbar, click  **Plot**.
- 7 Click the  **Zoom Extents** button in the **Graphics** toolbar.

Cut Plane 2



- 1 In the **Results** toolbar, click  **Cut Plane**.
- 2 In the **Settings** window for **Cut Plane**, locate the **Plane Data** section.
- 3 From the **Plane** list, choose **XZ-planes**.
- 4 Locate the **Data** section. From the **Dataset** list, choose **Submodel/Solution 2 (3) (sol2)**.

Cut Plane Stress - Submodel

- 1 In the **Results** toolbar, click  **2D Plot Group**.
- 2 In the **Settings** window for **2D Plot Group**, type **Cut Plane Stress - Submodel** in the **Label** text field.
- 3 Locate the **Color Legend** section. Select the **Show maximum and minimum values** checkbox.
- 4 Locate the **Data** section. From the **Dataset** list, choose **Cut Plane 2**.

Surface 1

- 1 Right-click **Cut Plane Stress - Submodel** and choose **Surface**.
- 2 In the **Settings** window for **Surface**, locate the **Expression** section.
- 3 In the **Expression** text field, type **solid2.mises**.
- 4 Locate the **Quality** section. From the **Evaluation settings** list, choose **Manual**.

- 5 From the **Resolution** list, choose **No refinement**.
- 6 From the **Smoothing** list, choose **None**.
- 7 In the **Cut Plane Stress - Submodel** toolbar, click  **Plot**.
- 8 Click the  **Zoom Extents** button in the **Graphics** toolbar.

Now verify that the differences in stress between the full model and the submodel are small where the displacements are mapped.

Cut Plane 3

- 1 In the **Results** toolbar, click  **Cut Plane**.
- 2 In the **Settings** window for **Cut Plane**, locate the **Plane Data** section.
- 3 In the **X-coordinate** text field, type 26.

Stress Comparison

- 1 In the **Results** toolbar, click  **2D Plot Group**.
- 2 In the **Settings** window for **2D Plot Group**, type Stress Comparison in the **Label** text field.
- 3 Locate the **Data** section. From the **Dataset** list, choose **None**.
- 4 Click to expand the **Title** section. From the **Title type** list, choose **Manual**.
- 5 In the **Title** text area, type Comparison of von Mises stress (MPa).
- 6 Locate the **Color Legend** section. Select the **Show units** checkbox.

Surface 1

- 1 Right-click **Stress Comparison** and choose **Surface**.
- 2 In the **Settings** window for **Surface**, locate the **Data** section.
- 3 From the **Dataset** list, choose **Cut Plane 3**.
- 4 Locate the **Expression** section. In the **Expression** text field, type `solid.misesGp`.
- 5 Locate the **Quality** section. From the **Evaluation settings** list, choose **Manual**.
- 6 From the **Resolution** list, choose **No refinement**.
- 7 From the **Smoothing** list, choose **None**.

Filter 1

- 1 Right-click **Surface 1** and choose **Filter**.
- 2 In the **Settings** window for **Filter**, locate the **Element Selection** section.
- 3 In the **Logical expression for inclusion** text field, type `Z>0`.
- 4 In the **Stress Comparison** toolbar, click  **Plot**.



Surface 1

- 1 In the **Model Builder** window, under **Results** right-click **Datasets** and choose **Surface**.
- 2 In the **Settings** window for **Surface**, locate the **Data** section.
- 3 From the **Dataset** list, choose **Submodel/Solution 2 (3) (sol2)**.
- 4 Select Boundary 1 only.
- 5 Locate the **Parameterization** section. From the **x- and y-axes** list, choose **YZ-plane**.

Surface 2

- 1 In the **Model Builder** window, right-click **Stress Comparison** and choose **Surface**.
- 2 In the **Settings** window for **Surface**, locate the **Data** section.
- 3 From the **Dataset** list, choose **Surface 1**.
- 4 Locate the **Expression** section. In the **Expression** text field, type `solid2.misesGp`.
- 5 Locate the **Quality** section. From the **Evaluation settings** list, choose **Manual**.
- 6 From the **Resolution** list, choose **No refinement**.
- 7 From the **Smoothing** list, choose **None**.
- 8 Click to expand the **Inherit Style** section. From the **Plot** list, choose **Surface 1**.

Transformation 1



- 1 Right-click **Surface 2** and choose **Transformation**.
- 2 In the **Settings** window for **Transformation**, locate the **Transformation** section.
- 3 In the **x** text field, type 11.
- 4 In the **Stress Comparison** toolbar, click  **Plot**.
- 5 Click the  **Zoom Extents** button in the **Graphics** toolbar.

Surface 3

- 1 In the **Model Builder** window, under **Results > Stress Comparison** right-click **Surface 2** and choose **Duplicate**.
- 2 In the **Settings** window for **Surface**, locate the **Expression** section.
- 3 In the **Expression** text field, type `solid2.misesGp-comp1.genext1(solid.misesGp)`.
- 4 Locate the **Inherit Style** section. From the **Plot** list, choose **None**.
- 5 Locate the **Coloring and Style** section. From the **Color table** list, choose **Wave**.
- 6 From the **Scale** list, choose **Linear symmetric**.

Transformation 1

- 1 In the **Model Builder** window, expand the **Surface 3** node, then click **Transformation 1**.

- 2 In the **Settings** window for **Transformation**, locate the **Transformation** section.
- 3 In the **x** text field, type 22.
- 4 In the **Stress Comparison** toolbar, click  **Plot**.
- 5 Click the  **Zoom Extents** button in the **Graphics** toolbar.

The solution is computed, follow the steps below if you want to save and reuse the model in the future.

FULL MODEL

Step 1: Stationary

- 1 In the **Model Builder** window, under **Full Model** click **Step 1: Stationary**.
- 2 In the **Settings** window for **Stationary**, locate the **Physics and Variables Selection** section.
- 3 In the **Solve for** column of the table, under **Submodel (comp2)**, clear the checkbox for **Solid Mechanics 2 (solid2)**.

