



Model created in COMSOL Multiphysics 6.4

Pacemaker Electrode

Introduction

This example illustrates the use of COMSOL Multiphysics for modeling of ionic current distribution problems in electrolytes, in this case in human tissue. The problem is exemplified on a pacemaker electrode, but it can be applied in electrochemical cells like fuel cells, batteries, corrosion protection, or any other process where ionic conduction takes place in the absence of concentration gradients.

The modeled device is a pacemaker electrode that is placed inside the heart and helps the patient's heart to keep a normal rhythm. The device is referred to as an electrode, but it actually consists of two electrodes: a cathode and an anode.

Figure 1 shows a schematic drawing of two pair of electrodes placed inside the heart. The electrodes are supplied with current from the pulse generator unit, which is also implanted in the patient.

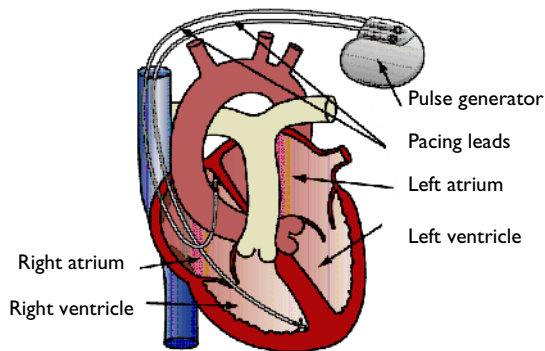

Figure 1: Schematic drawing of the heart with two pairs of pacemaker electrodes.

This example deals with the current and potential distribution around one pair of electrodes.

Model Definition

The model domain consists of the blood and tissue surrounding the electrode pair. The actual electrodes and the electrode support are boundaries to the modeled domain.

Figure 2 shows the electrode in a darker shade, while the surrounding modeling domain is shown in a lighter shade.

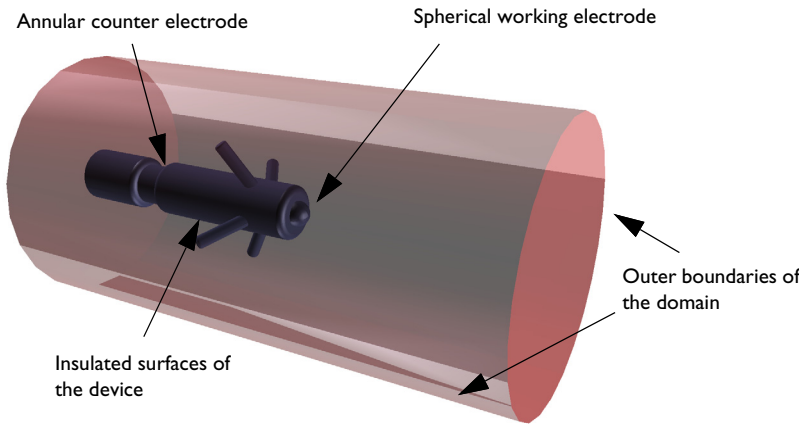

Figure 2: Modeling domain and boundaries.

The working electrode consists of a hemisphere placed on the tip of the supporting cylindrical structure. The counter electrode is placed in the “waist” of this structure. All other surfaces of the supporting structure are insulated. The outer boundaries are placed far enough from the electrode to give a small impact on the current and potential distribution.

In COMSOL Multiphysics, use the Electric Currents interface for the analysis of the electrode. This physics interface is useful for modeling conductive materials where a current flows due to an applied electric field.

DOMAIN EQUATIONS

The current in the domain is controlled by the continuity equation, which follows from Maxwell’s equations:

$$-\nabla \cdot (\sigma \nabla V) = 0$$

where σ is the conductivity of the human tissue. This equation uses the following relations between the electric potential and the fields.

$$\begin{aligned} \mathbf{E} &= -\nabla V \\ \mathbf{J} &= \sigma \mathbf{E} \end{aligned}$$

BOUNDARY CONDITIONS

Ground potential boundary conditions are applied on the thinner waist of the electrode. The tip of the electrode has a fixed potential of 1 V. All other boundaries are electrically insulated.

$$\mathbf{n} \cdot \mathbf{J} = 0$$

Results and Discussion

This simulation gives the potential distribution on the electrode surface and streamlines of the current distribution inside the human heart; see [Figure 3](#).

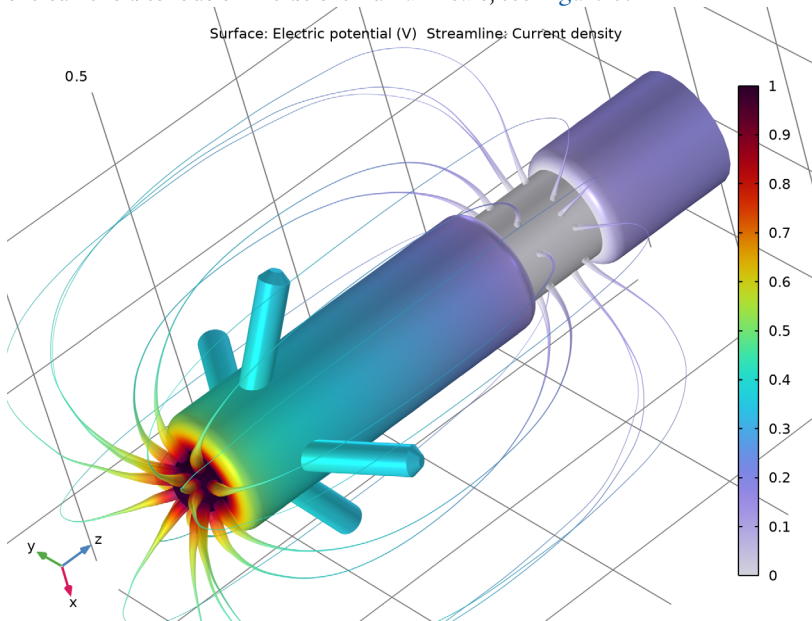

Figure 3: The plot shows the electrostatic potential distributed on the surface of the electrode. The total current density is shown as streamlines.

As expected, the current density is highest at the small hemisphere, which is the one that causes the excitation of the heart. The current density is fairly uniform on the working electrode. The counter electrode is larger and there are also larger variations in current density on its surface. Mainly, the current is lower with increasing distance from the working electrode. The model shows that the anchoring arms of the device have little influence on the current density distribution.

Application Library path: COMSOL_Multiphysics/Electromagnetics/
pacemaker_electrode



Modeling Instructions

From the **File** menu, choose **New**.

NEW

In the **New** window, click  **Model Wizard**.

MODEL WIZARD

- 1 In the **Model Wizard** window, click .
- 2 In the **Select Physics** tree, select **AC/DC > Electric Fields and Currents > Electric Currents (ec)**.
- 3 Click **Add**.
- 4 Click  **Study**.
- 5 In the **Select Study** tree, select **General Studies > Stationary**.
- 6 Click  **Done**.

GEOMETRY I

Insert the geometry sequence from the pacemaker_electrode_geom_sequence.mph file.

- 1 In the **Geometry** toolbar, click **Insert Sequence** and choose **Insert Sequence**.
- 2 Browse to the model's Application Libraries folder and double-click the file pacemaker_electrode_geom_sequence.mph.
- 3 In the **Geometry** toolbar, click  **Build All**.

Next, define the volume surrounding the electrode. The simulation only takes place in this volume, where the boundaries of the electrode influence the result.

Cylinder 1 (cyl1)

- 1 In the **Geometry** toolbar, click  **Cylinder**.
- 2 In the **Settings** window for **Cylinder**, locate the **Size and Shape** section.
- 3 In the **Radius** text field, type 10 [mm].

- 4 In the **Height** text field, type 40[mm].
- 5 Locate the **Position** section. In the **z** text field, type -20[mm].

Difference 1 (dif1)

- 1 In the **Geometry** toolbar, click  **Booleans and Partitions** and choose **Difference**.
- 2 Select the object **cyll** only.
- 3 In the **Settings** window for **Difference**, locate the **Difference** section.
- 4 From the **Objects to subtract** list, choose **Electrode**.

Form Union (fin)



In the **Geometry** toolbar, click  **Build All**.

DEFINITIONS

Next, define a selection corresponding to the grounded electrode for later use.

GEOMETRY 1

Counter Electrode

- 1 In the **Geometry** toolbar, click  **Selections** and choose **Explicit Selection**.
- 2 In the **Settings** window for **Explicit Selection**, locate the **Entities to Select** section.
- 3 From the **Geometric entity level** list, choose **Boundary**.
- 4 Select the **Group by continuous tangent** checkbox.
- 5 Click the  **Wireframe Rendering** button in the **Graphics** toolbar.

6 On the object **fin**, select Boundaries 29, 30, 58, and 63 only.

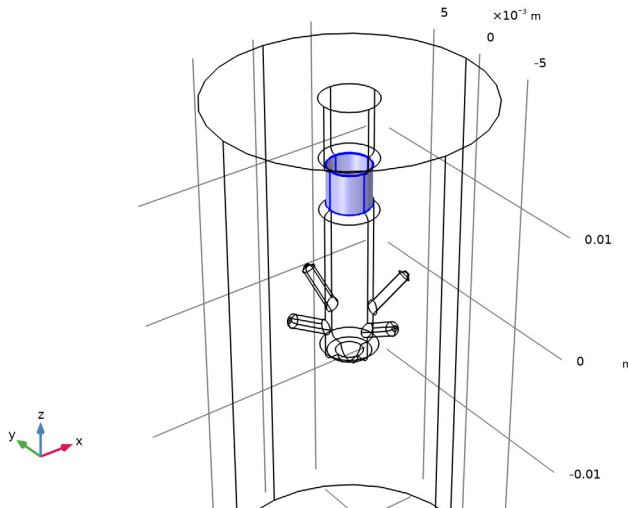

7 In the **Label** text field, type Counter Electrode.

8 Click the  **Wireframe Rendering** button in the **Graphics** toolbar to restore the default rendering state.

MATERIALS

A convenient way to find out which material parameters you need to specify is to add a material. COMSOL Multiphysics then indicates any missing parameters for the physics interfaces you have added to the model.

Heart Tissue

1 In the **Model Builder** window, under **Component 1 (comp1)** right-click **Materials** and choose **Blank Material**.

By default, the first material you add applies to all domains, so you do not need to modify the geometric scope.

The electrode is inserted into the human heart, so you must specify the conductivity for the heart tissue.

2 In the **Settings** window for **Material**, locate the **Material Contents** section.

3 In the table, enter the following settings:

Property	Variable	Value	Unit	Property group
Electric conductivity	sigma_iso ; sigma_ii = sigma_iso, sigma_ij = 0	0.4 [S/m]	S/m	Basic
Relative permittivity	epsilon_r_iso ; epsilon_rii = epsilon_r_iso, epsilon_r_ij = 0	1		Basic

4 In the **Label** text field, type Heart Tissue.

ELECTRIC CURRENTS (EC)

The only physics settings that remain to specify are the electrode potentials.

Ground I

- 1 In the **Physics** toolbar, click  **Boundaries** and choose **Ground**.
- 2 In the **Settings** window for **Ground**, locate the **Boundary Selection** section.
- 3 From the **Selection** list, choose **Counter Electrode**.

Electric Potential I

- 1 In the **Physics** toolbar, click  **Boundaries** and choose **Electric Potential**.
- 2 In the **Settings** window for **Electric Potential**, locate the **Boundary Selection** section.
- 3 From the **Selection** list, choose **Spherical Electrode**.
- 4 Locate the **Electric Potential** section. In the V_0 text field, type 1.

MESH I

- 1 In the **Model Builder** window, under **Component 1 (comp1)** click **Mesh 1**.
- 2 In the **Settings** window for **Mesh**, locate the **Physics-Controlled Mesh** section.
- 3 From the **Element size** list, choose **Coarser**.

4 Click  **Build All**.

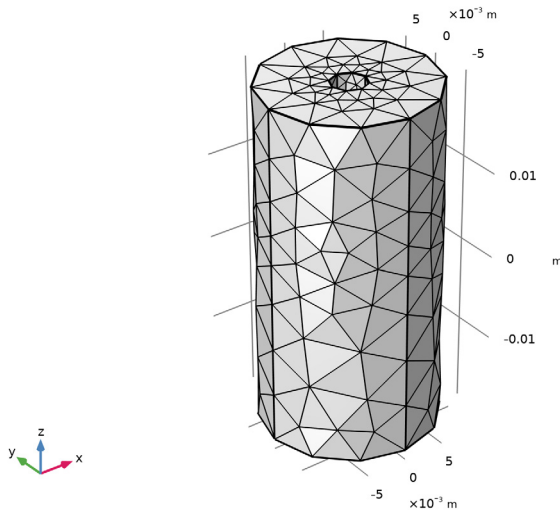

STUDY 1

Use the default settings for the stationary solver, which gives the conjugate gradients iterative solver with algebraic multigrid as the preconditioner.

1 In the **Study** toolbar, click  **Compute**.

RESULTS



Electric Potential (ec)

The default plot shows the slices of the electric potential. To reproduce the plot shown in [Figure 3](#), start by hiding the outer boundaries.

ELECTRIC CURRENTS (EC)

1 In the **Model Builder** window, under **Component 1 (comp1)** click **Electric Currents (ec)**.

2 Click the  **Click and Hide** button in the **Graphics** toolbar.

3 In the **Graphics** window toolbar, click  next to  **Select Domains**, then choose **Select Boundaries**.

4 Select Boundaries 1–4, 45, and 74 only.

5 Click the  **Click and Hide** button in the **Graphics** toolbar.

RESULTS

3D Plot Group 3

- 1 In the **Results** toolbar, click  **3D Plot Group**.
- 2 In the **Settings** window for **3D Plot Group**, locate the **Plot Settings** section.
- 3 Clear the **Plot dataset edges** checkbox.

Surface 1

- 1 Right-click **3D Plot Group 3** and choose **Surface**.
- 2 In the **3D Plot Group 3** toolbar, click  **Plot**.

3D Plot Group 3

Combine the surface plot of the potential with streamlines visualizing the total current density.

Streamline 1

- 1 In the **Model Builder** window, right-click **3D Plot Group 3** and choose **Streamline**.
- 2 In the **Settings** window for **Streamline**, locate the **Selection** section.
- 3 From the **Selection** list, choose **All boundaries**.
- 4 Locate the **Streamline Positioning** section. From the **Positioning** list, choose **Starting-point controlled**.
- 5 Locate the **Coloring and Style** section. Find the **Line style** subsection. From the **Type** list, choose **Tube**.
- 6 In the **Tube radius expression** text field, type $\min(\text{ec.normJ}/0.1[\text{mA}/\text{mm}^2], 1) * 0.2[\text{mm}]$. `ec.normJ` is the variable for the current density norm. This expression states that tubes are 0.2[mm] wide in the points having 0.1[mA/mm²]. The "min" function saturates the increase of the tube radius where current density approaches 0.1[mA/mm²].
To get suitably thick streamlines you need to adjust the scale factor.
- 7 Select the **Radius scale factor** checkbox.
- 8 In the **3D Plot Group 3** toolbar, click  **Plot**.

Color Expression 1

- 1 Right-click **Streamline 1** and choose **Color Expression**.
Use the default expression. Because it is the same as the surface expression, you can disable the color legend:
- 2 In the **Settings** window for **Color Expression**, locate the **Coloring and Style** section.

- 3 Clear the **Color legend** checkbox.

After proper rotation and zoom operations, you should see something similar to the plot in [Figure 3](#).

Surface 1

- 1 In the **Model Builder** window, under **Results > 3D Plot Group 3** click **Surface 1**.
- 2 In the **Settings** window for **Surface**, locate the **Coloring and Style** section.
- 3 From the **Color table** list, choose **PrismDark**.

Streamline 1

- 1 In the **Model Builder** window, click **Streamline 1**.
- 2 In the **Settings** window for **Streamline**, locate the **Streamline Positioning** section.
- 3 From the **Positioning** list, choose **On selected entities**.
- 4 Locate the **Selection** section. Click  **Clear Selection**.
- 5 Select Boundaries 29–32, 58–60, and 63 only.

Transparency 1

Right-click **Streamline 1** and choose **Transparency**.

Color Expression 1

- 1 In the **Settings** window for **Color Expression**, locate the **Coloring and Style** section.
- 2 From the **Color table** list, choose **Prism**.

Transparency 1

- 1 In the **Model Builder** window, click **Transparency 1**.
- 2 In the **Settings** window for **Transparency**, locate the **Transparency** section.
- 3 Find the **Transparency** subsection. Set the **Transparency** value to **0.4**.

