



Model created in COMSOL Multiphysics 6.4

# Sensitivity Analysis of a Communication Mast Detail

## Introduction

---

The example [Stiffness Analysis of a Communication Mast's Diagonal Mounting](#) in the COMSOL Multiphysics Application Libraries shows how you can modify a 3D CAD model to improve its performance. In that case, the applied changes were based solely on the analyst's experience with similar structures. A senior design engineer can sometimes reach acceptable performance after analyzing only a handful of designs, while an inexperienced analyst may have to spend a lot of time on failed attempts.

Usually, you can indeed improve a design by trial and error, but it is difficult to ensure that the price you pay — in this example, added weight and material costs — is as low as possible. With sensitivity analysis, you can find the most cost-efficient direction for a small modification and estimate the effect it has before attempting an updated design.

## Model Definition

---

The original model simulates the deformation of a part of a communication mast, shown in [Figure 1](#), under loads in the linear regime. The ratio of the part's effective stiffness to the stiffness of an equal length of a straight pipe is evaluated as a measure of its performance. Using sensitivity analysis together with a Deformed Geometry interface, you can predict what effect changing the dimensions of the end plate and the mount plates has on the part's relative stiffness.

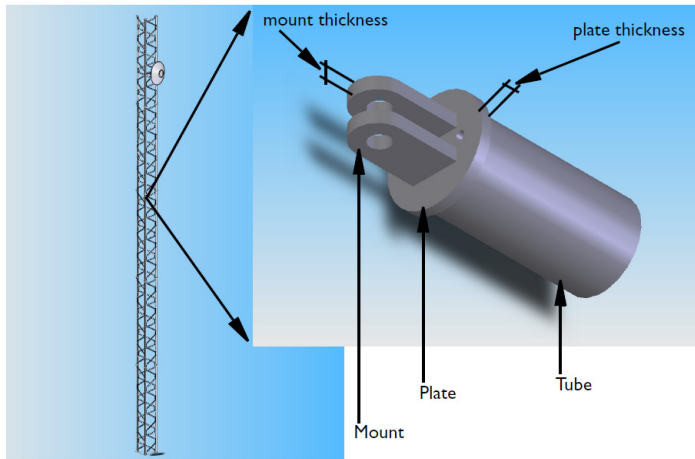

*Figure 1: Mounting details of a mast diagonal.*

From the designer’s point of view, the material thickness of the end plate,  $t_p$ , and of the mount plates,  $t_m$ , are the most relevant parameters because they are easy to change both in the CAD system and on the production line. These quantities are, however, not directly comparable to each other because a unit change of  $t_p$  incurs a different cost — added weight and material use — compared to a unit change in  $t_m$ .

For a fair analysis, it is therefore more convenient to parameterize the model in terms of the masses  $\Delta m_p$  and  $\Delta m_m$  added to the end plate and mount, respectively. The relation between added mass,  $\Delta m$ , and thickness change,  $\Delta t$ , is given by

$$\Delta m = \rho A \Delta t$$

where  $A$  is the area affected by the thickness change and  $\rho$  is the mass density of the material.

As output from a sensitivity analysis using the stiffness ratio,  $S_R$  (c.f. the example [Stiffness Analysis of a Communication Mast’s Diagonal Mounting](#) for the derivation), as objective function and the differential masses  $\Delta m_p$  and  $\Delta m_m$  as sensitivity variables, you get the partial derivatives

$$Q_p = \frac{\partial S_R}{\partial m_p} \quad Q_m = \frac{\partial S_R}{\partial m_m}$$

For a modified geometry corresponding to small values of  $\Delta m_p$  and  $\Delta m_m$  you can therefore expect to see a change in the stiffness ratio equal to

$$\Delta S_R = Q_p \Delta m_p + Q_m \Delta m_m$$

Note that this relation holds only for a small incremental change from the current configuration because the stiffness ratio is clearly a nonlinear function of the thicknesses. Now suppose that you want to select the best possible design update for a given added mass  $\Delta m = \Delta m_p + \Delta m_m$  with the added condition that both  $\Delta m_p$  and  $\Delta m_m$  are nonnegative. It is not too difficult to realize that the best option is to take  $\Delta m_p = \Delta m$ ,  $\Delta m_m = 0$  if  $Q_p > Q_m$ , and  $\Delta m_p = 0$ ,  $\Delta m_m = \Delta m$  otherwise.

The optimal stiffness for a given total mass of the structure can be sought by relaxing the nonnegativity condition for the updates and instead restricting the maximum change in  $\Delta m_p$  and  $\Delta m_m$  during one iteration. With the total mass as only constraint, you find the optimum design at a point where  $Q_p = Q_m$ . This follows strictly from the Karush–Kuhn–Tucker conditions but also from the simple fact that at such a point, the increased stiffness from adding mass to the plate is exactly canceled by the decrease in stiffness from removing the same mass from the mount.

## PARAMETERIZING THE GEOMETRY

In the Sensitivity interface, you declare sensitivity variables, which can be used to parameterize the physics. The sensitivity variables can appear anywhere COMSOL Multiphysics accepts an expression containing the dependent variables. However, neither dependent variables nor sensitivity variables can be used directly to set dimensions in the geometry.

To evaluate the sensitivity of a model with respect to geometrical changes, the geometry must first be made an active part of the system of equations. You accomplish this by moving all physics onto a deformed configuration controlled by a Deformed Geometry interface, described in *Deformed Geometry and Moving Mesh* in the *COMSOL Multiphysics Reference Manual*. This interface sets up an equation governing the position of the mesh nodes inside the domains, while the outer shape of the domain is controlled by boundary conditions.

When doing sensitivity analysis, these boundary conditions are quite simple: on fixed surfaces, set the mesh displacement to zero; on surfaces that may be modified, specify the displacement in terms of the sensitivity variables. In this particular case, where the material thickness of the end plate and the mount can change, it is enough to set the normal displacement of these surfaces equal to the thickness change calculated from the corresponding added mass. For the latter calculation, assume the total undeformed length of the part to be fixed and define  $\Delta m_p$  as the net mass added when  $t_p$  increases.

On surfaces adjacent to a domain with a parameterized normal displacement, it is preferable to restrict the mesh displacement to zero only in the normal direction to avoid an inconsistent constraint on the common edge. However, any remaining inconsistencies do not invalidate your results completely but only effectively modify the parameterization. In cases like this, when the purpose of the analysis is a rough estimate and guidance for a manual redesign, such minor errors in the sensitivities are unimportant.

Another potential source of errors must be checked more carefully, though. Changing the material thickness of the mount also changes the area where the loading is applied. In the Solid Mechanics interface, you specify the load as a given force per area. If you keep this number fixed when the thickness of the part changes, the total applied load also changes; when evaluating the stiffness ratio of the composite part you must account for this effect. Alternatively, you can keep the total force fixed and make sure that the applied force per unit area is calculated using a hole area that follows the parameterization of the geometry. This is simply done by changing the expression for the mount hole  $xy$ -projected area to

$$A_{mh}^{xy} = 2 \cdot r_{mh}(t_m + \Delta t_m)$$

where  $\Delta t_m$  is the increase in the mount thickness.

### CHOOSING FORWARD OR ADJOINT SENSITIVITY ANALYSIS

By default, the **Sensitivity** interface uses the adjoint method, which is more efficient than the forward method when the number of sensitivity variables is large. When there is only a handful of scalar parameters, as in this case, the forward method has the advantage that it returns the sensitivity of the entire solution with respect to the sensitivity variables in addition to the sensitivity of the objective function. This additional information can sometimes be important in itself, but more often it is useful for checking the model setup because it is easy to visualize.

### *Results and Discussion*

---

The analysis shows that when the thickness of the end plate is 12 mm and the material thickness in the mount is 15 mm, the sensitivities to adding mass to the two details are  $Q_p = 0.25$  and  $Q_m = 0.23$ , respectively. Because, apparently, adding mass to the end plate has more effect than adding it to the mount, the next redesign of the part should be fitted with a thicker plate. You might even consider decreasing the material thickness of the mount while adding to the plate to keep the weight of the part constant.

Note that these conclusions only hold for the current instance of the design. An experienced analyst quickly realizes that the stiffness contribution of the plate is due to bending action, while the stiffness contribution of the mount is almost pure tensile action. A plate's resistance to bending grows as its thickness cubed, while resistance to tension is proportional to the cross-sectional area. Therefore, as the thickness of the plate increases, its contribution to the stiffness of the composite part increases rapidly.

If you increase the thickness of the end plate too much, the stiffness of the mount takes over as dominant factor in the overall behavior. Using sensitivity analysis, you can easily detect when this happens, because it leads to  $Q_m > Q_p$ . As noted above, an optimum design for a given total mass is found when  $Q_p = Q_m$ .

Because the sensitivity analysis was performed using the forward method, the derivatives of the solution with respect to the parameters  $\Delta m_p$  and  $\Delta m_m$  have also been stored. You can access this data when processing the results by using the syntax `sens(expr, var)`. For example, by plotting the expression `sens(w, dm_p)`, you can directly examine the local effect of a unit increase in the plate mass; see [Figure 2](#).

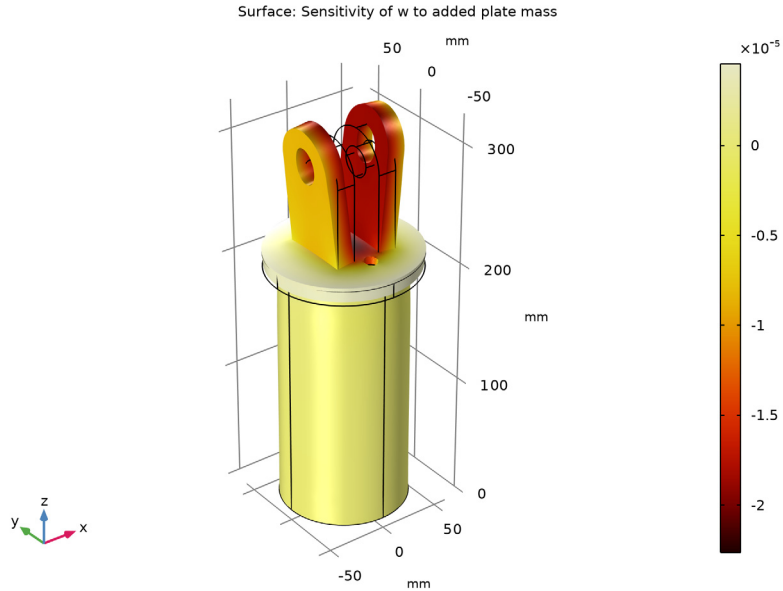

Figure 2: The influence of 1 mm mount thickness increase on the overall displacement.

---

**Application Library path:** COMSOL\_Multiphysics/Structural\_Mechanics/  
mast\_diagonal\_mounting\_sensitivity

---

### *Modeling Instructions*

---

#### **APPLICATION LIBRARIES**



- 1 From the **File** menu, choose **Application Libraries**.
- 2 In the **Application Libraries** window, select **COMSOL Multiphysics** > **Structural Mechanics** > **mast\_diagonal\_mounting** in the tree.
- 3 Click  **Open**.

#### **ADD PHYSICS**

- 1 In the **Home** toolbar, click  **Add Physics** to open the **Add Physics** window.
- 2 Go to the **Add Physics** window.

- 3 In the tree, select **Mathematics > Deformed Mesh > Legacy Deformed Mesh > Deformed Geometry (dg)**.
- 4 Find the **Physics interfaces in study** subsection. In the table, clear the **Solve** checkbox for **Study 1**.
- 5 Click the **Add to Component 1** button in the window toolbar.
- 6 In the **Home** toolbar, click  **Add Physics** to close the **Add Physics** window.

#### ADD STUDY

- 1 In the **Home** toolbar, click  **Add Study** to open the **Add Study** window.
- 2 Go to the **Add Study** window.
- 3 Find the **Studies** subsection. In the **Select Study** tree, select **General Studies > Stationary**.
- 4 Click the **Add Study** button in the window toolbar.
- 5 In the **Home** toolbar, click  **Add Study** to close the **Add Study** window.

#### GLOBAL DEFINITIONS

Modify the parameters for the plate thickness and mount thickness to correspond to the updated configuration of the original model.

##### *Parameters 1*

- 1 In the **Model Builder** window, under **Global Definitions** click **Parameters 1**.
- 2 In the **Settings** window for **Parameters**, locate the **Parameters** section.
- 3 In the table, modify the following settings:

Name	Expression	Value	Description
t_p	12[mm]	0.012 m	Plate thickness
t_m	15[mm]	0.015 m	Mount thickness



- 4 Next, define the masses added to the plate and mount that you will use later as global control variables.

Name	Expression	Value	Description
dm_p	0	0	Added mass, plate
dm_m	0	0	Added mass, mount

#### DEFINITIONS

Create a selection for the domains where the mesh will be allowed to deform.

### Deformed mesh domains

- 1 In the **Definitions** toolbar, click  **Union**.
- 2 In the **Settings** window for **Union**, locate the **Input Entities** section.
- 3 Under **Selections to add**, click **+ Add**.
- 4 In the **Add** dialog, in the **Selections to add** list, choose **End plate** and **Mount**.
- 5 Click **OK**.
- 6 In the **Settings** window for **Union**, type Deformed mesh domains in the **Label** text field.
- 7 Click the  **Wireframe Rendering** button in the **Graphics** toolbar.

### Outer mount faces

- 1 In the **Definitions** toolbar, click  **Nonlocal Couplings** and choose **Integration**.  
Add component couplings for integrating over the flat surfaces of the plate and mount.
- 2 In the **Settings** window for **Integration**, type  $dA_{mt}$  in the **Operator name** text field.
- 3 Locate the **Source Selection** section. From the **Geometric entity level** list, choose **Boundary**.
- 4 Select Boundaries 15 and 56 only.

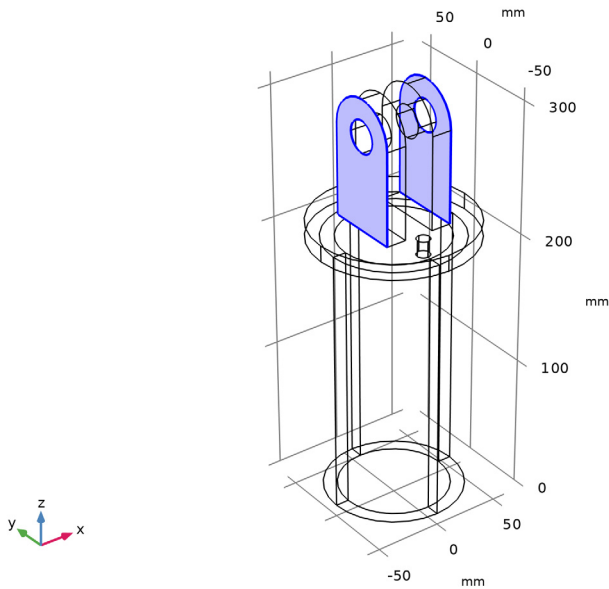

- 5 Click  **Create Selection**.
- 6 In the **Create Selection** dialog, type Outer mount faces in the **Selection name** text field.

7 Click **OK**.

8 In the **Settings** window for **Integration**, type Outer mount faces in the **Label** text field.

#### Plate surface

1 In the **Definitions** toolbar, click  **Nonlocal Couplings** and choose **Integration**.

2 In the **Settings** window for **Integration**, type dA\_p1 in the **Operator name** text field.

3 Locate the **Source Selection** section. From the **Geometric entity level** list, choose **Boundary**.

4 Select Boundary 4 only.

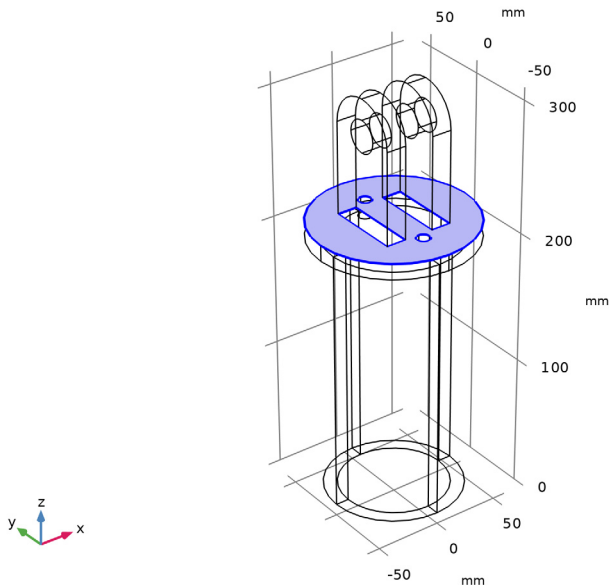

5 Click  **Create Selection**.

6 In the **Create Selection** dialog, type Plate surface in the **Selection name** text field.

7 Click **OK**.

8 In the **Settings** window for **Integration**, type Plate surface in the **Label** text field.

9 Click the  **Wireframe Rendering** button in the **Graphics** toolbar to return to the default state.

Next, define variables for the displacements as functions of the added masses.

#### Sensitivity Variables

1 In the **Definitions** toolbar, click  **Local Variables**.

- 2 In the **Settings** window for **Variables**, locate the **Variables** section.
- 3 In the table, enter the following settings:

Name	Expression	Unit	Description
mA_pl	dA_pl(solid.rho)	kg/m	Mass per unit thickness, plate
mA_mt	dA_mt(solid.rho)	kg/m	Mass per unit thickness, mount
dt_p	dm_p[kg]/mA_pl	m	Displacement, plate end face
dt_m	dm_m[kg]/mA_mt	m	Displacement, outer mount faces

The mass per unit thickness for the plate refers to the area outside the surface where the plate connects to the mount; thus, it gives the net added mass when the thickness of the plate increases.

- 4 In the **Label** text field, type **Sensitivity Variables**.

#### *Variables I*

Modify the variables that are affected by change in plate and mount thickness.

- 1 In the **Model Builder** window, click **Variables I**.
- 2 In the **Settings** window for **Variables**, locate the **Variables** section.
- 3 In the table, modify the following settings:

Name	Expression	Unit	Description
Axy_mh	2*r_mh*(t_m+dt_m)	m <sup>2</sup>	Mount hole xy projected area

By default, the mesh is fixed in all domains. Remove this constraint for the mount and plates by adding a **Free Deformation** node:

### **DEFORMED GEOMETRY (DG)**

#### *Free Deformation I*

- 1 In the **Physics** toolbar, click  **Domains** and choose **Free Deformation**.
- 2 In the **Settings** window for **Free Deformation**, locate the **Domain Selection** section.
- 3 From the **Selection** list, choose **Deformed mesh domains**.

The virtual boundary displacements must be described in a boundary system which does not rotate with the deformation.

## DEFINITIONS

### *Boundary System 1 (sys1)*

- 1 In the **Model Builder** window, under **Component 1 (comp1) > Definitions** click **Boundary System 1 (sys1)**.
- 2 In the **Settings** window for **Boundary System**, locate the **Settings** section.
- 3 From the **Frame** list, choose **Geometry configuration**.

## DEFORMED GEOMETRY (DG)

### *Prescribed Mesh Displacement 1*

- 1 In the **Model Builder** window, under **Component 1 (comp1) > Deformed Geometry (dg)** click **Prescribed Mesh Displacement 1**.
- 2 In the **Settings** window for **Prescribed Mesh Displacement**, locate the **Coordinate System Selection** section.
- 3 From the **Coordinate system** list, choose **Boundary System 1 (sys1)**.
- 4 Locate the **Prescribed Mesh Displacement** section. Clear the **Prescribed t1 displacement** checkbox.
- 5 Clear the **Prescribed t2 displacement** checkbox.

This default condition will apply to the boundaries where you do not prescribe nonzero displacements.

### *Prescribed Mesh Displacement 2*

- 1 In the **Physics** toolbar, click  **Boundaries** and choose **Prescribed Mesh Displacement**.
- 2 In the **Settings** window for **Prescribed Mesh Displacement**, locate the **Boundary Selection** section.
- 3 From the **Selection** list, choose **Outer mount faces**.
- 4 Locate the **Coordinate System Selection** section. From the **Coordinate system** list, choose **Boundary System 1 (sys1)**.
- 5 Locate the **Prescribed Mesh Displacement** section. Clear the **Prescribed t1 displacement** checkbox.
- 6 Clear the **Prescribed t2 displacement** checkbox.
- 7 In the  $d_n$  text field, type dt\_m.

### *Prescribed Mesh Displacement 3*

- 1 In the **Physics** toolbar, click  **Boundaries** and choose **Prescribed Mesh Displacement**.

- 2 In the **Settings** window for **Prescribed Mesh Displacement**, locate the **Boundary Selection** section.
- 3 From the **Selection** list, choose **Plate surface**.
- 4 Locate the **Coordinate System Selection** section. From the **Coordinate system** list, choose **Boundary System 1 (sys1)**.
- 5 Locate the **Prescribed Mesh Displacement** section. Clear the **Prescribed t1 displacement** checkbox.
- 6 Clear the **Prescribed t2 displacement** checkbox.
- 7 In the  $d_n$  text field, type  $dt\_p$ .

## STUDY 2

Now, set up the study. In particular, you need to add a **Sensitivity** node. But first, you must enable advanced study options.

- 1 Click the  **Show More Options** button in the **Model Builder** toolbar.
- 2 In the **Show More Options** dialog, in the tree, select the checkbox for the node **Study > Sensitivity**.
- 3 Click **OK**.

### Sensitivity

- 1 In the **Study** toolbar, click  **More Study Extensions** and choose **Sensitivity**.

By using the forward method, you will have access to the derivatives of the solution with respect to the sensitivity variables  $dm\_p$  and  $dm\_m$ .

- 2 In the **Settings** window for **Sensitivity**, locate the **Sensitivity Method** section.
- 3 From the **Gradient method** list, choose **Forward**.

The stiffness ratio computed in the original model serves as the objective function.

- 4 Click **Replace Expression** in the upper-right corner of the **Objective Function** section. From the menu, choose **Component 1 (comp1) > Definitions > Variables > comp1.S\_R - Stiffness ratio - 1**.

- 5 Locate the **Control Variables and Parameters** section. Click  **Add** twice.

- 6 In the table, enter the following settings:

Parameter	Value	Scale	Unit	Value type
$dm\_p$ (Added mass, plate)	0	1		Real
$dm\_m$ (Added mass, mount)	0	1		Real

7 In the **Study** toolbar, click  **Compute**.

## RESULTS

Begin by evaluating the sensitivities of the stiffness ratio with respect to the two types of small additions.

### Global Evaluation 3

- 1 In the **Results** toolbar, click  **Global Evaluation**.
- 2 In the **Settings** window for **Global Evaluation**, locate the **Data** section.
- 3 From the **Dataset** list, choose **Study 2/Solution 5 (sol5)**.
- 4 Locate the **Expressions** section. In the table, enter the following settings:

Expression	Unit	Description
<code>fsens(dm_m)</code>		

- 5 Click  **Evaluate**.

### Global Evaluation 4

- 1 Right-click **Global Evaluation 3** and choose **Duplicate**.
- 2 In the **Settings** window for **Global Evaluation**, locate the **Expressions** section.
- 3 In the table, enter the following settings:

Expression	Unit	Description
<code>fsens(dm_p)</code>		

- 4 Click the arrow next to the **Evaluate** button and choose **Table 3 - Global Evaluation 3 (fsens(dm\_m))**.

Create a plot for the sensitivity of axial displacement with respect to change in the added plate mass.

### Sensitivity

- 1 In the **Results** toolbar, click  **3D Plot Group**.
- 2 In the **Settings** window for **3D Plot Group**, type **Sensitivity** in the **Label** text field.
- 3 Locate the **Data** section. From the **Dataset** list, choose **Study 2/Solution 5 (sol5)**.

### Surface 1

- 1 Right-click **Sensitivity** and choose **Surface**.
- 2 In the **Settings** window for **Surface**, locate the **Expression** section.
- 3 In the **Expression** text field, type `sens(w, dm_p)`.

- 4 Locate the **Coloring and Style** section. From the **Color table** list, choose **ThermalDark**.
- 5 In the **Sensitivity** toolbar, click  **Plot**.

#### *Deformation 1*

- 1 Right-click **Surface 1** and choose **Deformation**.
- 2 In the **Settings** window for **Deformation**, locate the **Expression** section.
- 3 In the **X-component** text field, type  $u+1[\text{mm}] * m_{A\_p1} * \text{sens}(u, dm\_p)$ .
- 4 In the **Y-component** text field, type  $v+1[\text{mm}] * m_{A\_p1} * \text{sens}(v, dm\_p)$ .
- 5 In the **Z-component** text field, type  $w+1[\text{mm}] * m_{A\_p1} * \text{sens}(w, dm\_p)$ .

These deformations give a linear approximation of the deformation that would result from a 1 mm increase in the plate thickness.

- 6 In the **Sensitivity** toolbar, click  **Plot**.

#### *Sensitivity*

- 1 In the **Model Builder** window, under **Results** click **Sensitivity**.
- 2 In the **Settings** window for **3D Plot Group**, click to expand the **Title** section.
- 3 From the **Title type** list, choose **Manual**.
- 4 In the **Title** text area, type Surface: Sensitivity of w to added plate mass.
- 5 In the **Sensitivity** toolbar, click  **Plot**.