



Model created in COMSOL Multiphysics 6.4

Deformation of a Feeder Clamp

Introduction

This example, from the field of structural mechanics, analyzes the deformation of a feeder clamp under stress. The clamp secures a feeder that carries high-frequency electromagnetic fields, and it is important that it remains as straight as possible.

This example analyzes deformations in the clamp with the following questions in mind:

- How much does the force from the feeder incline the clamp? The inclination must be less than 1 degree.
- Does a prestressed screw of a certain type have enough strength to deform the clamp so that it adequately anchors the feeder? The gap must shrink by at least 0.5 mm.
- What happens if one of the mounting bolts is loose or missing?

Model Definition

In this analysis, the feeder clamp is bolted to a wall. The fastening can be made using either one or two mounting holes. The mounting using two holes represents a case when the fastening is properly made while fastening using only one hole represents a case when the clamp is poorly secured. The external forces on the clamp are introduced from the feeder as well as from the clamping screw, as shown in [Figure 1](#).

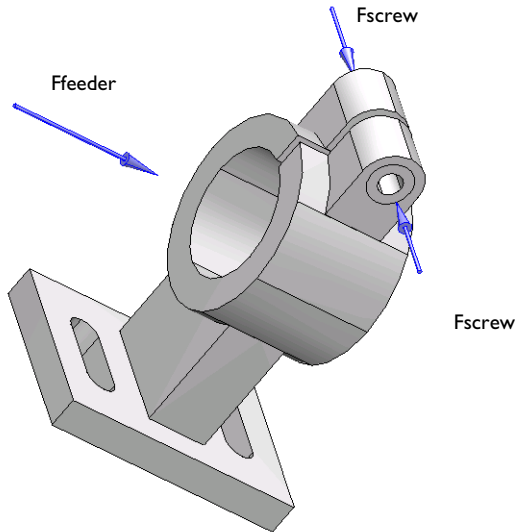

Figure 1: Applied forces.

LOADING DATA

The clamp is made of aluminum. Assume that an installation technician fastens the feeder into the clamp using a standard metric M3 screw of Class 8.8 (where the first digit stands for a breaking load of 800 N/mm^2 , and the second digit indicates a yield strength of 80% of the breaking strength). Prestressing the screw to the yield limit results in a screw force of 4500 N. This application tests if a screw force of 20% of this value is adequate. A 7-mm washer distributes the prestressed load evenly onto both sides of the sleeve. The maximum load from the feeder onto the clamp is 2000 N, and is applied evenly throughout the inner surface of the sleeve.

Due to symmetry in both loading and the geometry, you can perform a complete model analysis while looking at only one half of the geometry. For illustrative purposes though, this example models the entire geometry.

Results and Discussion

The deformation of the loaded clamp when secured with two bolts is shown in [Figure 2](#). In [Figure 3](#) the deformation is shown when fastening is made using only one bolt. The results indicate clearly a larger deformation when one fastening element is missing.

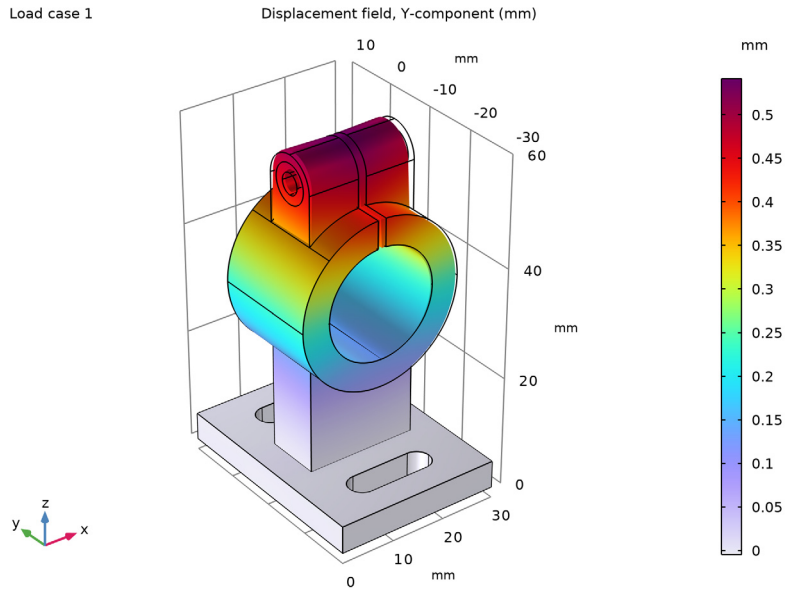

Figure 2: Displacement of the clamp in the loading direction in case of two mounting bolts.

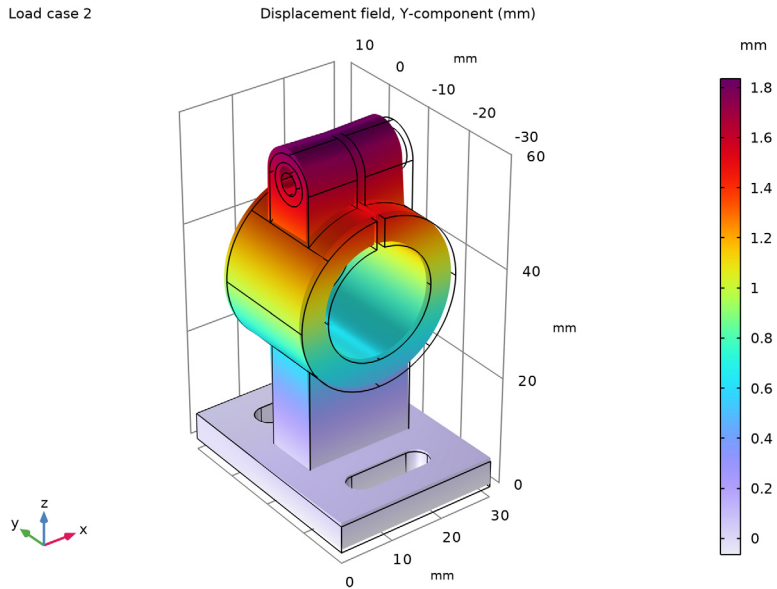

Figure 3: Displacement of the clamp in the loading direction in case of only one mounting bolt.

Since the problem is symmetric in the yz -plane the minimum separation of 0.5 mm can be visualized by evaluation of the expression $\text{abs}(u) > 0.25$ mm, shown in [Figure 4](#). The domains that are not colored green experience a greater displacement than 0.25 mm. Due to symmetry, this corresponds to the part of the clamp that undergoes a larger deformation than 0.5 mm, which is the minimum requirement for being able to fasten the feeder adequately. The boundary conditions in this example are valid only as long as the

installation technician does not squeeze the gap in the clamping sleeve completely shut. However, if the gap is squeezed shut, you can be sure that the requirements are fulfilled.

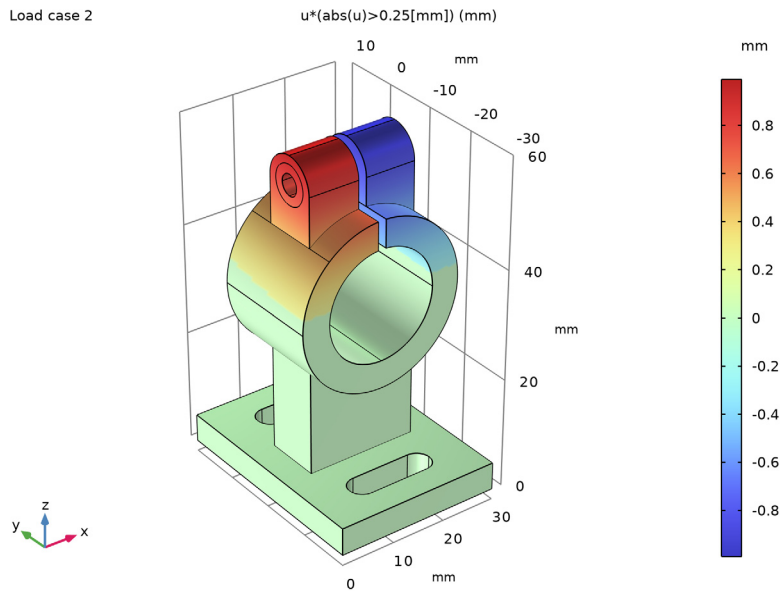

Figure 4: Clamp deformation caused by the screw force.

The rotation of the clamp is evaluated using the rotation tensor. Since deformations are small, the components of the rotation tensor equal the angle given in radians. In [Figure 5](#), the results are displayed in degrees. The rotation varies slightly over the generatrix of the inner sleeve surface. The computation gives an inclination value of approximately 0.5 degrees when both mounting bolts are present and tightened properly. This value is less than the maximum allowed angle of 1 degree. However, if one of the bolts is missing,

the angle increases to approximately 1.75 degrees, which significantly exceeds the allowed inclination.

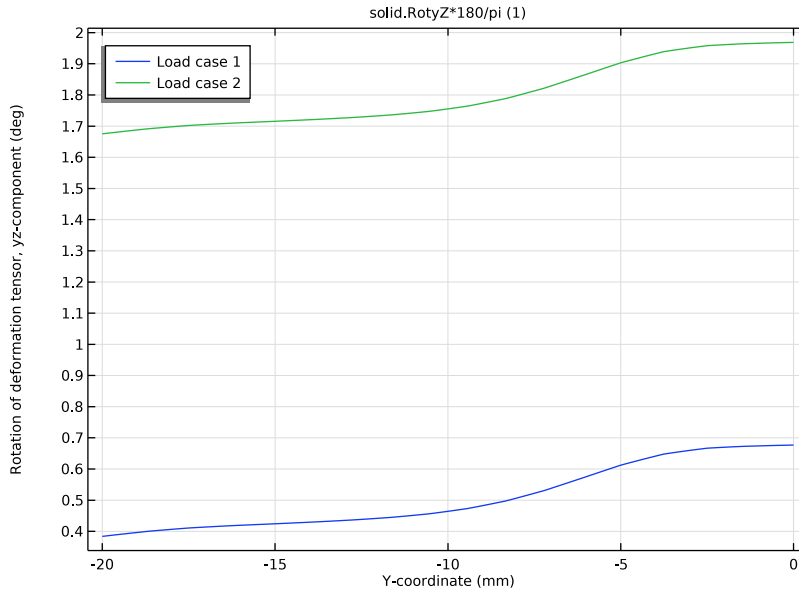



Figure 5: Rotation along the clamp.

Application Library path: COMSOL_Multiphysics/Structural_Mechanics/feeder_clamp

Modeling Instructions



From the **File** menu, choose **New**.

NEW

In the **New** window, click  **Model Wizard**.

MODEL WIZARD

- 1 In the **Model Wizard** window, click  **3D**.
- 2 In the **Select Physics** tree, select **Structural Mechanics > Solid Mechanics (solid)**.
- 3 Click **Add**.

- 4 Click  **Study**.
- 5 In the **Select Study** tree, select **General Studies > Stationary**.
- 6 Click  **Done**.

GLOBAL DEFINITIONS

Parameters 1

- 1 In the **Model Builder** window, under **Global Definitions** click **Parameters 1**.
- 2 In the **Settings** window for **Parameters**, locate the **Parameters** section.
- 3 In the table, enter the following settings:

Name	Expression	Value	Description
Ffeeder	2000 [N]	2000 N	Feeder force
Fscrew	$0.2 \cdot 4500$ [N]	900 N	Screw force

To add a parameter, you can either edit directly in an empty table row or use the text fields below the table and click **Move Up** when you are finished (you might need to click on the table row to activate the text fields first).

GEOMETRY 1

- 1 In the **Model Builder** window, under **Component 1 (comp1)** click **Geometry 1**.
- 2 In the **Settings** window for **Geometry**, locate the **Units** section.
- 3 From the **Length unit** list, choose **mm**.

Block 1 (blk1)

- 1 In the **Geometry** toolbar, click  **Block**.
- 2 In the **Settings** window for **Block**, locate the **Size and Shape** section.
- 3 In the **Width** text field, type 30 [mm].
- 4 In the **Depth** text field, type 40 [mm].
- 5 In the **Height** text field, type 5 [mm].
- 6 Locate the **Position** section. In the **y** text field, type -30 [mm].

Work Plane 1 (wp1)

- 1 In the **Geometry** toolbar, click  **Work Plane**.
- 2 In the **Settings** window for **Work Plane**, locate the **Plane Definition** section.
- 3 From the **Plane** list, choose **yz-plane**.
- 4 In the **x-coordinate** text field, type 5 [mm].

Work Plane 1 (wp1) > Plane Geometry

In the **Model Builder** window, click **Plane Geometry**.

Work Plane 1 (wp1) > Rectangle 1 (r1)

- 1 In the **Work Plane** toolbar, click  **Rectangle**.
- 2 In the **Settings** window for **Rectangle**, locate the **Size and Shape** section.
- 3 In the **Width** text field, type 10[mm].
- 4 In the **Height** text field, type 55[mm].
- 5 Locate the **Position** section. In the **xw** text field, type -15[mm].
- 6 In the **yw** text field, type 5[mm].

Work Plane 1 (wp1) > Fillet 1 (fil1)

- 1 In the **Work Plane** toolbar, click  **Fillet**.
- 2 On the object **r1**, select Points 3 and 4 only.

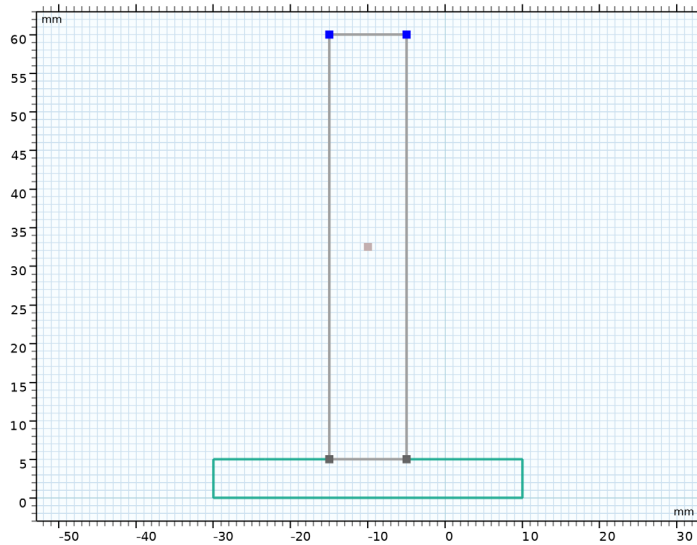

- 3 In the **Settings** window for **Fillet**, locate the **Radius** section.
- 4 In the **Radius** text field, type 5[mm].

Work Plane 1 (wp1) > Circle 1 (c1)



- 1 In the **Work Plane** toolbar, click  **Circle**.
- 2 In the **Settings** window for **Circle**, locate the **Size and Shape** section.
- 3 In the **Radius** text field, type 3.5[mm].

- 4 Locate the **Position** section. In the **xw** text field, type -10[mm].
- 5 In the **yw** text field, type 55[mm].

Work Plane 1 (wp1) > Circle 2 (c2)

- 1 Right-click **Component 1 (comp1) > Geometry 1 > Work Plane 1 (wp1) > Plane Geometry > Circle 1 (c1)** and choose **Duplicate**.
- 2 In the **Settings** window for **Circle**, locate the **Size and Shape** section.
- 3 In the **Radius** text field, type 1.875[mm].

Work Plane 1 (wp1) > Difference 1 (dif1)

- 1 In the **Work Plane** toolbar, click  **Booleans and Partitions** and choose **Difference**.
- 2 Select the objects **c1** and **fill** only.
- 3 In the **Settings** window for **Difference**, locate the **Difference** section.
- 4 Click to select the  **Activate Selection** toggle button for **Objects to subtract**.
- 5 Select the object **c2** only.
- 6 Click  **Build Selected**.

Extrude 1 (ext1)

- 1 In the **Model Builder** window, under **Component 1 (comp1) > Geometry 1** right-click **Work Plane 1 (wp1)** and choose **Extrude**.
- 2 In the **Settings** window for **Extrude**, locate the **Distances** section.
- 3 In the table, enter the following settings:

Distances (mm)
20[mm]

4 Click  **Build Selected**.

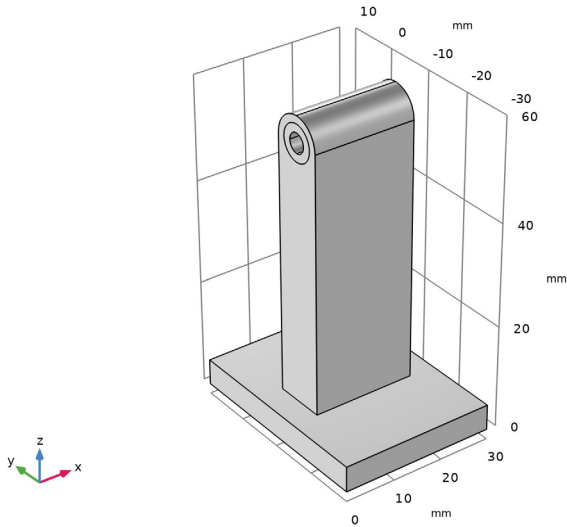

Cylinder 1 (cyl1)

- 1 In the **Geometry** toolbar, click  **Cylinder**.
- 2 In the **Settings** window for **Cylinder**, locate the **Size and Shape** section.
- 3 In the **Radius** text field, type 15[mm].
- 4 In the **Height** text field, type 20[mm].
- 5 Locate the **Position** section. In the **x** text field, type 15[mm].
- 6 In the **y** text field, type -20[mm].
- 7 In the **z** text field, type 35[mm].
- 8 Locate the **Axis** section. From the **Axis type** list, choose **y-axis**.

Union 1 (un1)

- 1 In the **Geometry** toolbar, click  **Booleans and Partitions** and choose **Union**.

2 Select the objects **cyll** and **extI** only.

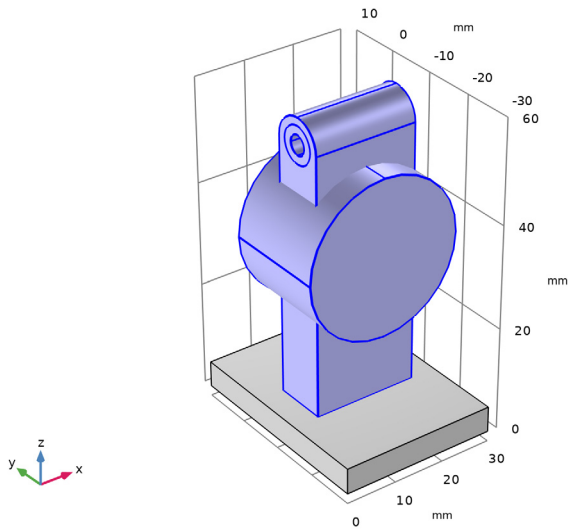

3 In the **Settings** window for **Union**, locate the **Union** section.

4 Clear the **Keep interior boundaries** checkbox.

Partition the geometry to enable structured meshing.

Partition Faces 1 (parf1)

1 In the **Geometry** toolbar, click  **Booleans and Partitions** and choose **Partition Faces**.

2 On the object **uni1**, select Boundaries 1, 2, 19, and 20 only.

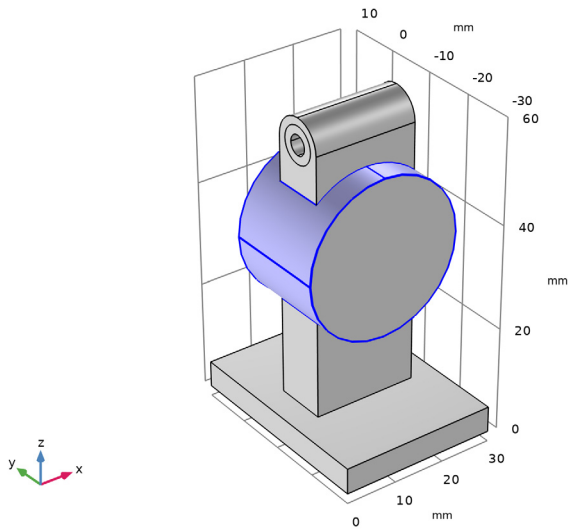

3 In the **Settings** window for **Partition Faces**, locate the **Partition Faces** section.

4 From the **Partition with** list, choose **Extended edges**.

5 On the object **uni1**, select Edges 9, 12, 50, and 52 only.

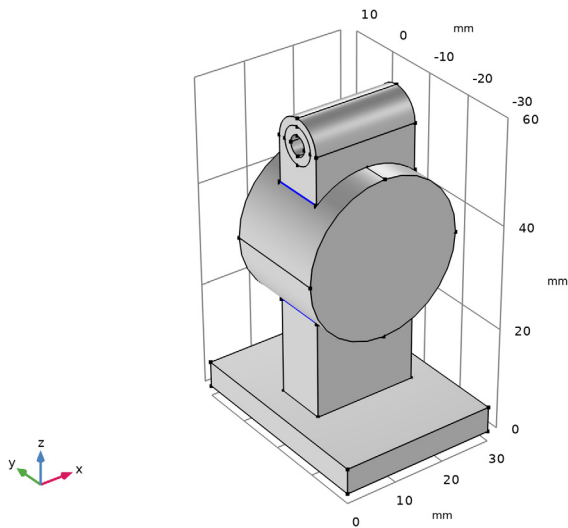

Partition Domains 1 (pard1)

- 1 In the **Geometry** toolbar, click  **Booleans and Partitions** and choose **Partition Domains**.
- 2 On the object **parf1**, select Domain 1 only.
- 3 In the **Settings** window for **Partition Domains**, locate the **Partition Domains** section.
- 4 From the **Partition with** list, choose **Extended faces**.
- 5 On the object **parf1**, select Boundary 2 only.

Cylinder 2 (cyl2)

- 1 In the **Geometry** toolbar, click  **Cylinder**.
- 2 In the **Settings** window for **Cylinder**, locate the **Size and Shape** section.
- 3 In the **Radius** text field, type 10[mm].
- 4 In the **Height** text field, type 20[mm].
- 5 Locate the **Position** section. In the **x** text field, type 15[mm].
- 6 In the **y** text field, type -20[mm].
- 7 In the **z** text field, type 35[mm].
- 8 Locate the **Axis** section. From the **Axis type** list, choose **y-axis**.

Block 2 (blk2)

- 1 In the **Geometry** toolbar, click  **Block**.
- 2 In the **Settings** window for **Block**, locate the **Size and Shape** section.
- 3 In the **Width** text field, type 1.5[mm].
- 4 In the **Depth** text field, type 20[mm].
- 5 In the **Height** text field, type 20[mm].
- 6 Locate the **Position** section. In the **x** text field, type 14.25[mm].
- 7 In the **y** text field, type -20[mm].
- 8 In the **z** text field, type 40[mm].

Work Plane 2 (wp2)

- 1 In the **Geometry** toolbar, click  **Work Plane**.
- 2 In the **Settings** window for **Work Plane**, locate the **Plane Definition** section.
- 3 From the **Plane type** list, choose **Face parallel**.
- 4 On the object **blk1**, select Boundary 1 only.

Work Plane 2 (wp2) > Plane Geometry

In the **Model Builder** window, click **Plane Geometry**.

Work Plane 2 (wp2) > Rectangle 1 (r1)

- 1 In the **Work Plane** toolbar, click  **Rectangle**.
- 2 In the **Settings** window for **Rectangle**, locate the **Size and Shape** section.
- 3 In the **Width** text field, type 11[mm].
- 4 In the **Height** text field, type 5[mm].
- 5 Locate the **Position** section. In the **xw** text field, type -5.5[mm].
- 6 In the **yw** text field, type -15[mm].

Work Plane 2 (wp2) > Circle 1 (c1)

- 1 In the **Work Plane** toolbar, click  **Circle**.
- 2 In the **Settings** window for **Circle**, locate the **Size and Shape** section.
- 3 In the **Radius** text field, type 2.5[mm].
- 4 Locate the **Position** section. In the **xw** text field, type -5.5[mm].
- 5 In the **yw** text field, type -12.5[mm].

Work Plane 2 (wp2) > Circle 2 (c2)

- 1 Right-click **Component 1 (comp1) > Geometry 1 > Work Plane 2 (wp2) > Plane Geometry > Circle 1 (c1)** and choose **Duplicate**.
- 2 In the **Settings** window for **Circle**, locate the **Position** section.
- 3 In the **xw** text field, type 5.5[mm].

Work Plane 2 (wp2) > Mirror 1 (mir1)

- 1 In the **Work Plane** toolbar, click  **Transforms** and choose **Mirror**.
- 2 Click in the **Graphics** window and then press Ctrl+A to select all objects.
- 3 In the **Settings** window for **Mirror**, locate the **Normal Vector to Line of Reflection** section.
- 4 In the **xw** text field, type 0.
- 5 In the **yw** text field, type 1.
- 6 Locate the **Input** section. Select the **Keep input objects** checkbox.

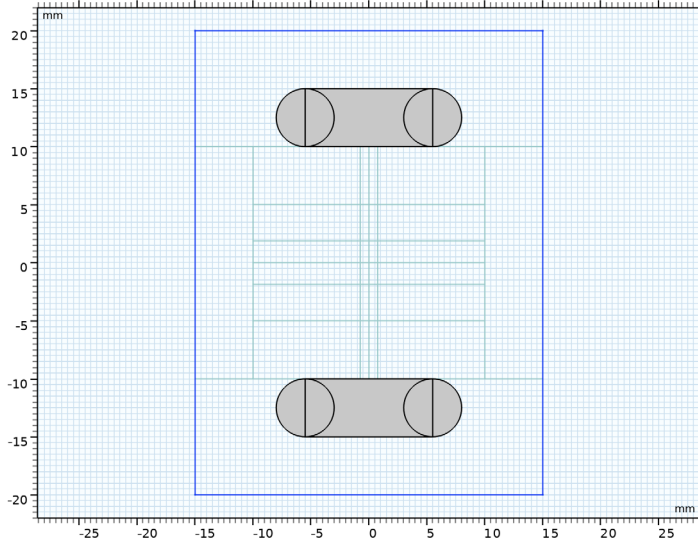

7 Click  **Build Selected.**



Extrude 2 (ext2)

- 1 In the **Model Builder** window, under **Component 1 (comp1) > Geometry 1** right-click **Work Plane 2 (wp2)** and choose **Extrude**.
- 2 In the **Settings** window for **Extrude**, locate the **Distances** section.
- 3 From the **Specify** list, choose **Vertices to extrude to**.
- 4 On the object **blk1**, select Point 7 only.

Difference 1 (dif1)

- 1 In the **Geometry** toolbar, click  **Booleans and Partitions** and choose **Difference**.
- 2 Select the objects **blk1** and **pard1** only.
- 3 In the **Settings** window for **Difference**, locate the **Difference** section.
- 4 Click to select the  **Activate Selection** toggle button for **Objects to subtract**.
- 5 Select the objects **blk2**, **cyl2**, and **ext2** only.



Partition Faces 2 (parf2)

- 1 In the **Geometry** toolbar, click  **Booleans and Partitions** and choose **Partition Faces**.
- 2 On the object **dif1**, select Boundary 17 only.
- 3 In the **Settings** window for **Partition Faces**, locate the **Partition Faces** section.

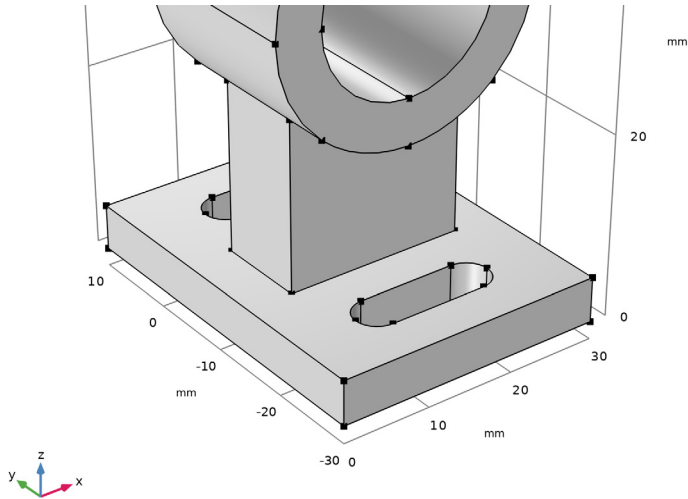

- 4 Click to select the  **Activate Selection** toggle button for **Vertices defining curve segments.**
- 5 On the object **difl**, select Points 57 and 58 only.



Form Union (fin)

- 1 In the **Model Builder** window, click **Form Union (fin)**.
- 2 In the **Settings** window for **Form Union/Assembly**, click  **Build Selected**.
- 3 Click  **Build Selected**.
- 4 Click the  **Go to Default View** button in the **Graphics** toolbar.

ADD MATERIAL

- 1 In the **Materials** toolbar, click  **Add Material** to open the **Add Material** window.
- 2 Go to the **Add Material** window.
- 3 In the tree, select **Built-in > Aluminum**.
- 4 Click the **Add to Component** button in the window toolbar.
- 5 In the **Materials** toolbar, click  **Add Material** to close the **Add Material** window.

SOLID MECHANICS (SOLID)

The boundary conditions consist of loads and constraints. The latter model the mounting bolts by setting the displacement to zero at the mounting holes off the clamp. All other boundaries are free.

Boundary Load 1

- 1 In the **Physics** toolbar, click  **Boundaries** and choose **Boundary Load**.
- 2 Select Boundary 22 only.

It might be easier to select the correct boundary by using the **Selection List** window. To open this window, in the **Home** toolbar click **Windows** and choose **Selection List**. (If you are running the cross-platform desktop, you find **Windows** in the main menu.)

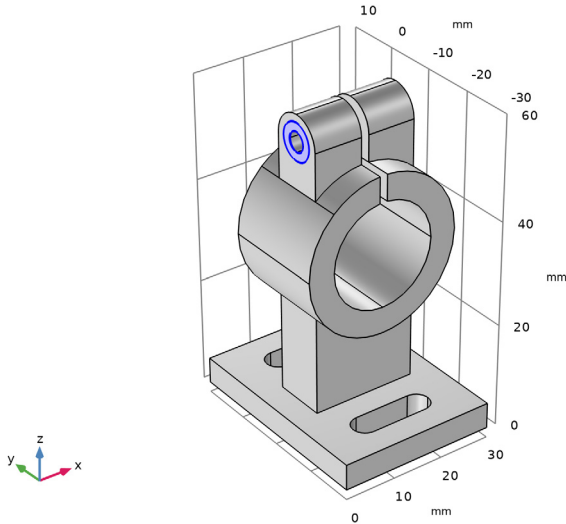

- 3 In the **Settings** window for **Boundary Load**, locate the **Force** section.
- 4 From the **Load type** list, choose **Total force**.
- 5 Specify the \mathbf{F}_{tot} vector as

Fscrew	x
--------	---

Boundary Load 2

- 1 In the **Physics** toolbar, click  **Boundaries** and choose **Boundary Load**.
- 2 Select Boundary 68 only.
- 3 In the **Settings** window for **Boundary Load**, locate the **Force** section.
- 4 From the **Load type** list, choose **Total force**.
- 5 Specify the \mathbf{F}_{tot} vector as



-Fscrew	x
---------	---

Boundary Load 3

- 1 In the **Physics** toolbar, click  **Boundaries** and choose **Boundary Load**.
- 2 Select Boundaries 11, 12, 43, and 47 only.
- 3 In the **Settings** window for **Boundary Load**, locate the **Force** section.
- 4 From the **Load type** list, choose **Total force**.
- 5 Specify the \mathbf{F}_{tot} vector as

Ffeeder	y
---------	---

Fixed Constraint 1

- 1 In the **Physics** toolbar, click  **Boundaries** and choose **Fixed Constraint**.
- 2 Select Boundaries 34, 35, 38, 39, 62, and 63 only.
Assign the constraint grouping to be able to disable or enable the corresponding constraint in a parametric analysis.
- 3 In the **Physics** toolbar, click  **Constraint Group** and choose **New Constraint Group**.

Fixed Constraint 2

- 1 Right-click **Fixed Constraint 1** and choose **Duplicate**.
- 2 Select Boundaries 32, 33, 36, 37, 60, and 61 only.
- 3 In the **Physics** toolbar, click  **Constraint Group** and choose **New Constraint Group**.

MESH 1

Swept 1

In the **Mesh** toolbar, click  **Swept**.

Size

- 1 In the **Model Builder** window, click **Size**.
- 2 In the **Settings** window for **Size**, locate the **Element Size** section.
- 3 From the **Predefined** list, choose **Extremely fine**.

Swept 1

- 1 In the **Model Builder** window, click **Swept 1**.
- 2 In the **Settings** window for **Swept**, click to expand the **Source Faces** section.
- 3 Select Boundaries 18 and 22 only.

4 Click  **Build All**.

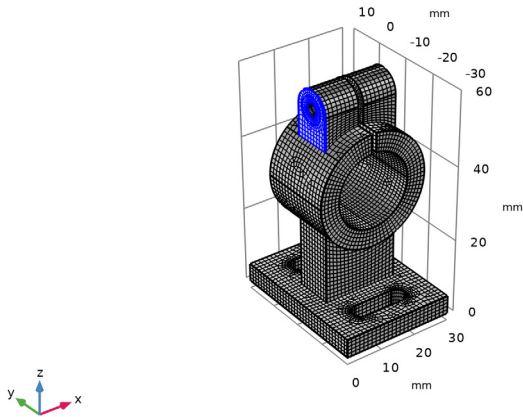

STUDY I

Step 1: Stationary

- 1 In the **Model Builder** window, under **Study I** click **Step 1: Stationary**.
- 2 In the **Settings** window for **Stationary**, click to expand the **Study Extensions** section.
Set up two load cases: the first one with both mounting bolts present and the second one with one of the bolts either loose or missing completely.
- 3 Select the **Define load cases** checkbox.
- 4 Click **+ Add**.
- 5 Click **+ Add**.
- 6 In the table, enter the following settings:

Load case	cg1	cg2
Load case 1	√	√
Load case 2	√	

Solution 1 (sol1)

- 1 In the **Study** toolbar, click  **Show Default Solver**.
- 2 In the **Model Builder** window, expand the **Solution I (sol1)** node, then click **Stationary Solver 1**.

- 3 In the **Settings** window for **Stationary Solver**, click to expand the **Output** section.
- 4 Clear the **Reaction forces** checkbox.
- 5 In the **Study** toolbar, click  **Compute**.



RESULTS

The default plot shows the stress distribution over the deformed geometry. Change it to visualize the displacement in the loading direction.

y-Displacement LC1

- 1 In the **Model Builder** window, under **Results** click **Stress (solid)**.
- 2 In the **Settings** window for **3D Plot Group**, type *y-Displacement LC1* in the **Label** text field.
- 3 Locate the **Color Legend** section. Select the **Show units** checkbox.

Volume 1

- 1 In the **Model Builder** window, expand the **y-Displacement LC1** node, then click **Volume 1**.
- 2 In the **Settings** window for **Volume**, click **Replace Expression** in the upper-right corner of the **Expression** section. From the menu, choose **Component 1 (comp1) > Solid Mechanics > Displacement > Displacement field - m > v - Displacement field, Y-component**.
- 3 In the **y-Displacement LC1** toolbar, click  **Plot**.
- 4 Click the  **Zoom Extents** button in the **Graphics** toolbar.

The plot seems to indicate that the gap in the sleeve has been shut. However, this is an artifact of the default scale factor being larger than 1. To get an accurate view of the size of the deformation, set the scale factor to 1.

Deformation

- 1 In the **Model Builder** window, expand the **Volume 1** node, then click **Deformation**.
- 2 In the **Settings** window for **Deformation**, locate the **Scale** section.
- 3 Select the **Scale factor** checkbox. In the associated text field, type 1.

y-Displacement LC1



- 1 In the **Model Builder** window, under **Results** click **y-Displacement LC1**.
- 2 In the **Settings** window for **3D Plot Group**, locate the **Data** section.
- 3 From the **Load case** list, choose **Load case 1**.
- 4 In the **y-Displacement LC1** toolbar, click  **Plot**.

- 5 Click the  **Zoom Extents** button in the **Graphics** toolbar.

The resulting plot should be similar to that shown in [Figure 2](#). Thus, there is still a narrow gap in the sleeve (if necessary, rotate the geometry in the **Graphics** window to get a better view).

y-Displacement LC2

Now, duplicate the plot to show the second case with one of the mounting bolts missing, [Figure 3](#).



- 1 Right-click **y-Displacement LC1** and choose **Duplicate**.
- 2 In the **Settings** window for **3D Plot Group**, type *y-Displacement LC2* in the **Label** text field.
- 3 Locate the **Data** section. From the **Load case** list, choose **Load case 2**.
- 4 In the **y-Displacement LC2** toolbar, click  **Plot**.
- 5 Click the  **Zoom Extents** button in the **Graphics** toolbar.

Proceed to reproduce the plot shown in [Figure 4](#).

x-Displacement

- 1 In the **Results** toolbar, click  **3D Plot Group**.
- 2 In the **Settings** window for **3D Plot Group**, type *x-Displacement* in the **Label** text field.
- 3 Locate the **Color Legend** section. Select the **Show units** checkbox.

Surface 1

- 1 Right-click **x-Displacement** and choose **Surface**.
- 2 In the **Settings** window for **Surface**, locate the **Expression** section.
- 3 In the **Expression** text field, type $u * (\text{abs}(u) > 0.25[\text{mm}])$.
- 4 Locate the **Coloring and Style** section. From the **Color table** list, choose **RainbowLight**.
- 5 In the **x-Displacement** toolbar, click  **Plot**.
- 6 Click the  **Zoom Extents** button in the **Graphics** toolbar.

You can flip the **Load case** selector on the plot **Data** tab to see that the increase in inclination has almost no effect on the clamp deformation due to the screw forces.

Examine the resulting rotation of the clamp by evaluating the rotation of the deformation tensor.

Rotation

- 1 In the **Results** toolbar, click  **ID Plot Group**.
- 2 In the **Settings** window for **ID Plot Group**, type *Rotation* in the **Label** text field.

- 3 Locate the **Legend** section. From the **Position** list, choose **Upper left**.

Line Graph 1

- 1 Right-click **Rotation** and choose **Line Graph**.
- 2 Select Edge 95 only.

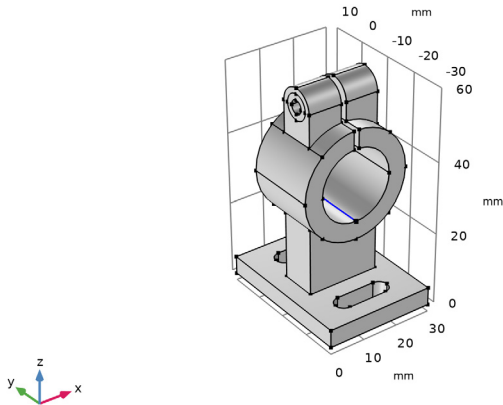

- 3 In the **Settings** window for **Line Graph**, click **Replace Expression** in the upper-right corner of the **y-Axis Data** section. From the menu, choose **Component I (comp1) > Solid Mechanics > Strain > Rotation of deformation tensor > solid.RotyZ - Rotation of deformation tensor, yZ component**.
- 4 Locate the **y-Axis Data** section. In the **Expression** text field, type `solid.RotyZ*180/pi`.
- 5 Locate the **x-Axis Data** section. From the **Parameter** list, choose **Expression**.
- 6 In the **Expression** text field, type `Y`.
- 7 Click to expand the **Legends** section. Select the **Show legends** checkbox.

Rotation

- 1 In the **Model Builder** window, click **Rotation**.
- 2 In the **Settings** window for **ID Plot Group**, locate the **Plot Settings** section.
- 3 Select the **y-axis label** checkbox. In the associated text field, type `Rotation of deformation tensor, yz-component (deg)`.

