



Model created in COMSOL Multiphysics 6.4

Busbar Assembly Geometry – with Group Nodes

Introduction

Group nodes in the Model Tree can help with the organization of models by grouping feature nodes that belong together, for example, nodes that belong to a particular part of the geometry, in a folder-like structure.

You can collapse group nodes, drag the group nodes to rearrange them, or drag other nodes to or from the group nodes. Actions like hiding can be applied to all members of a group node, making it more efficient to work with more complex geometries.

Follow this tutorial to create the busbar geometry used in the model [Electrical Heating in a Busbar Assembly](#) while learning more about how to:

- Collect geometry feature nodes into group nodes
- Set up work planes with user defined local coordinate systems
- Position geometry objects in various ways

[Busbar Assembly Geometry — with Geometry Parts](#), the first part of this tutorial series, describes how to build a geometry that consists of several components by using geometry parts. The two tutorials in this series complement each other, and show methods to structure more complex geometry sequences.

Model Definition

This example contains the detailed steps to create the parameterized geometry used for the model [Electrical Heating in a Busbar Assembly](#). The geometry for this model, displayed in

Figure 1, includes the coupling components for one cell, and a section of the intercell busbar that is connected to a cell grid.

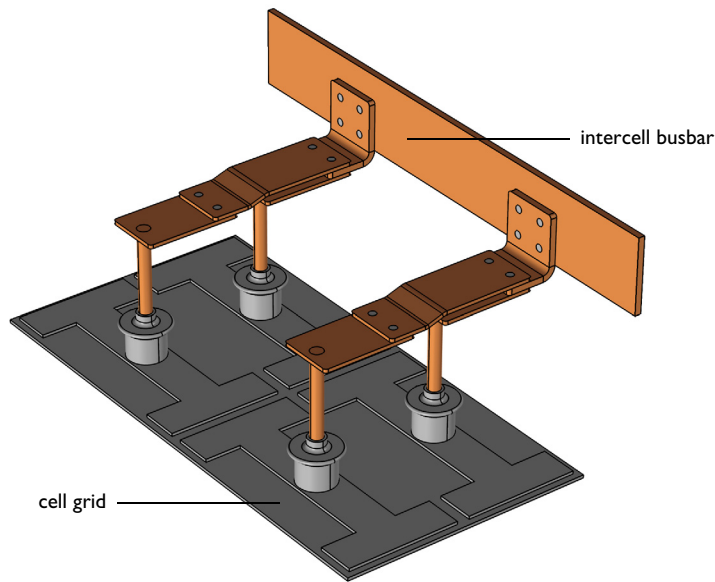

Figure 1: The busbar assembly.

When creating the geometry, you will collect feature nodes that build the components of the busbar into separate group nodes. Another approach to organize the geometry sequence could be to group the feature nodes based on, for example, the material properties.

This example describes only the process of creating the geometry sequence. For the physics setup, follow the instructions in [Electrical Heating in a Busbar Assembly](#).

Application Library path: COMSOL_Multiphysics/Geometry_Tutorials/
busbar_assembly_groups_geometry

Modeling Instructions

From the **File** menu, choose **New**.

NEW

In the **New** window, click  **Blank Model**.

Load the parameters that define the geometry

GLOBAL DEFINITIONS

Parameters 1

- 1 In the **Model Builder** window, under **Global Definitions** click **Parameters 1**.
- 2 In the **Settings** window for **Parameters**, locate the **Parameters** section.
- 3 Click  **Load from File**.
- 4 Browse to the model's Application Libraries folder and double-click the file `busbar_assembly_groups_geom_parameters.txt`.



ADD COMPONENT

In the **Home** toolbar, click  **Add Component** and choose **3D**.

GEOMETRY 1

- 1 In the **Settings** window for **Geometry**, locate the **Units** section.
- 2 From the **Length unit** list, choose **mm**.

Cell Grid Top

- 1 In the **Geometry** toolbar, click  **Block**.
- 2 In the **Settings** window for **Block**, type `Cell Grid Top` in the **Label** text field.
- 3 Locate the **Size and Shape** section. In the **Width** text field, type `c_g_w`.
- 4 In the **Depth** text field, type `c_g_1`.
- 5 In the **Height** text field, type `c_g_h`.
- 6 Locate the **Position** section. From the **Base** list, choose **Center**.
- 7 In the **z** text field, type `c_g_h/2`.
- 8 Locate the **Selections of Resulting Entities** section. Find the **Cumulative selection** subsection. Click **New**.
- 9 In the **New Cumulative Selection** dialog, type `Titanium` in the **Name** text field.
- 10 Click **OK**.
- 11 In the **Settings** window for **Block**, click  **Highlight Result** to make it easier to identify the output of the various features.

12 Click  **Build Selected.**

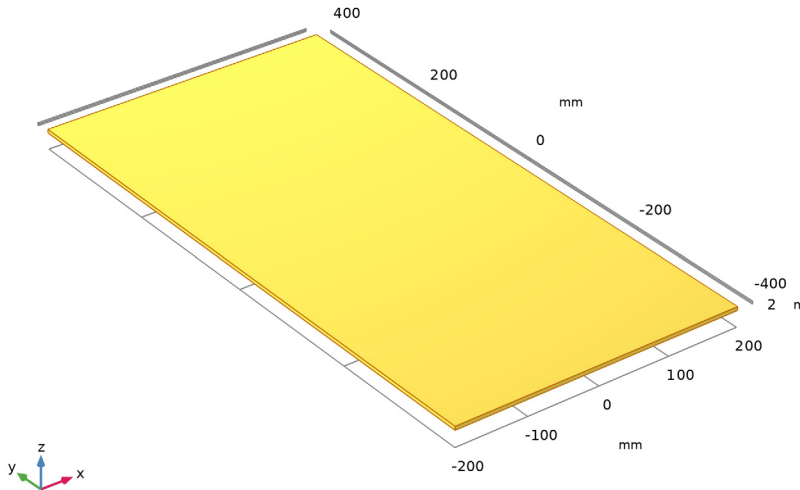

Work Plane 1 (wp1)

1 In the **Geometry** toolbar, click  **Work Plane.**

The next part is placed on top of **blk 1**.

2 In the **Settings** window for **Work Plane**, locate the **Plane Definition** section.

3 From the **Plane type** list, choose **Face parallel.**

4 On the object **blk 1**, select Boundary 4 only.

5 Click to expand the **Local Coordinate System** section. In the **xw-displacement** text field, type $-c_g_w/2+s_di$.

6 In the **yw-displacement** text field, type $-c_g_l/2+s_di$.

Specifying the origin of the local coordinate system ensures that the objects drawn on the work plane are correctly positioned without having to move them later.

7 Click  **Go to Plane Geometry** on top of the **Settings** window.

Work Plane 1 (wp1) > Plane Geometry

This brings you automatically to the **Sketch** toolbar, but we will instead work with the tools on the **Work Plane** toolbar.

Leave the Sketch mode and create the geometry by entering the polygon coordinates.

1 In the **Sketch** toolbar, click  **Sketch**.

Work Plane 1 (wp1) > Polygon 1 (pol1)

1 In the **Work Plane** toolbar, click  **Polygon**.

2 In the **Settings** window for **Polygon**, locate the **Coordinates** section.

3 In the table, enter the following settings:

xw (mm)	yw (mm)
0	0
0	s_c_1
s_w/2-s_c_w/2	s_c_1
s_w/2-s_c_w/2	s_l-s_c_1
0	s_l-s_c_1
0	s_l
s_w	s_l
s_w	s_l-s_c_1
s_w/2+s_c_w/2	s_l-s_c_1
s_w/2+s_c_w/2	s_c_1
s_w	s_c_1
s_w	0

4 Click  **Build Selected.**

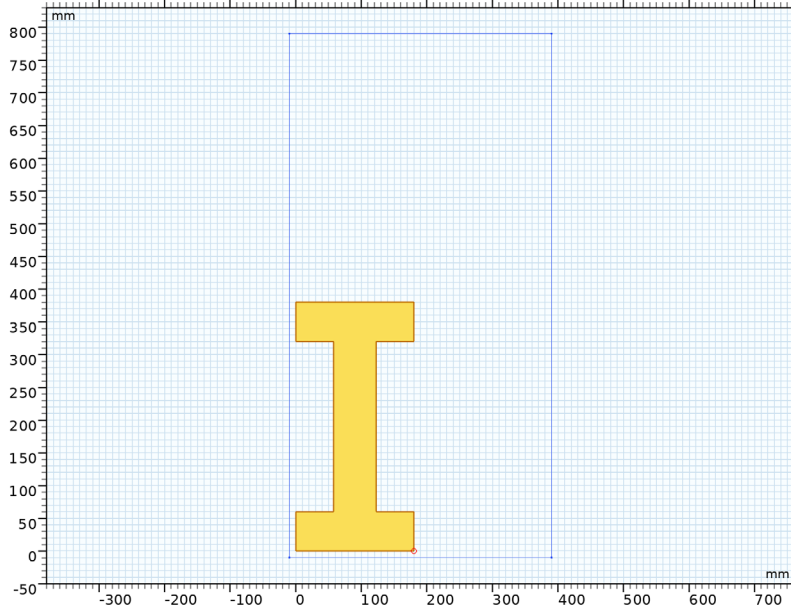

Extrude 1 (ext1)

- 1 In the **Model Builder** window, under **Component 1 (comp1) > Geometry 1** right-click **Work Plane 1 (wp1)** and choose **Extrude**.
- 2 In the **Settings** window for **Extrude**, locate the **Distances** section.
- 3 In the table, enter the following settings:

Distances (mm)
s_h

- 4 Locate the **Selections of Resulting Entities** section. Find the **Cumulative selection** subsection. From the **Contribute to** list, choose **Titanium**.

5 Click  **Build Selected**.

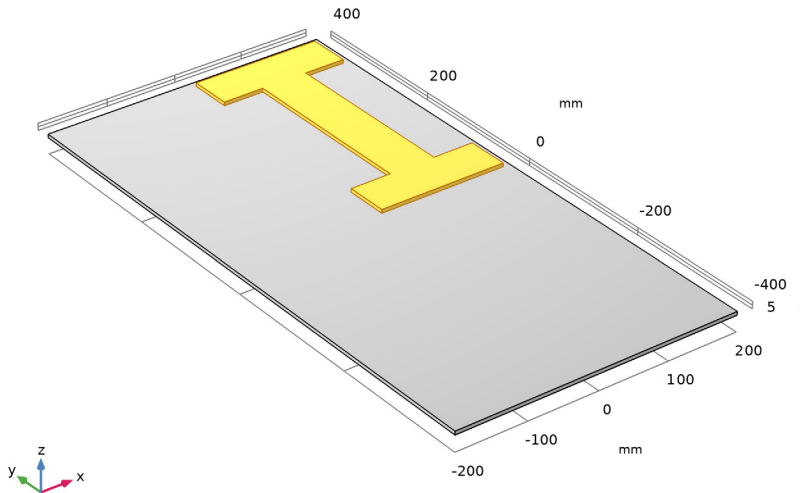

Extrude 1 (ext1), Work Plane 1 (wp1)

The **Work Plane 1** and **Extrude 1** nodes create the object for the spine part of the busbar and can be grouped together in the sequence.

- 1 In the **Model Builder** window, under **Component 1 (comp1) > Geometry 1**, Ctrl-click to select **Work Plane 1 (wp1)** and **Extrude 1 (ext1)**.
- 2 Right-click and choose **Group**.

Spine

In the **Settings** window for **Group**, type Spine in the **Label** text field.

Work Plane 2 (wp2)

- 1 In the **Geometry** toolbar, click  **Work Plane**.
Work Plane 2 is inserted after **Extrude 1** within the **Spine** group node, but you can move it outside the group, as it will be used to create the central column part of the busbar.
- 2 Right-click **Work Plane 2 (wp2)** and choose **Move Out**.
- 3 In the **Model Builder** window, click **Work Plane 2 (wp2)**.
- 4 In the **Settings** window for **Work Plane**, locate the **Plane Definition** section.
- 5 From the **Plane** list, choose **zx-plane**.

- 6 In the **y-coordinate** text field, type $c_g_1/4$.
- 7 Locate the **Local Coordinate System** section. In the **xw-displacement** text field, type $c_g_h+s_h$.
- 8 In the **yw-displacement** text field, type $c_g_w/4$.

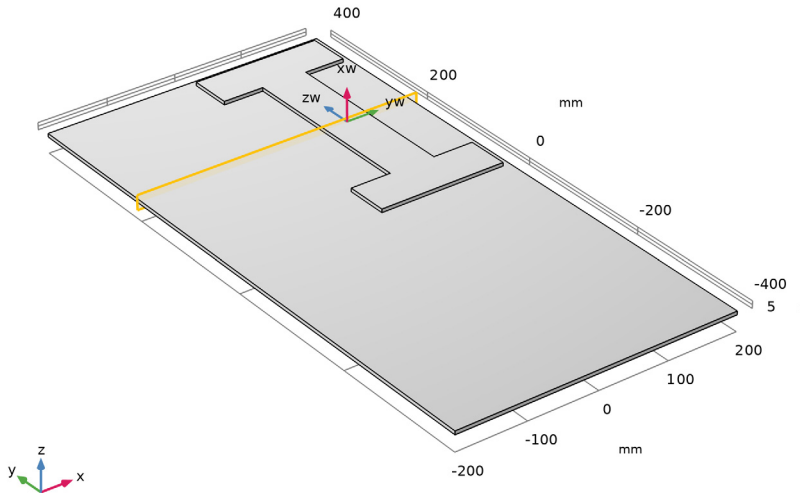

You will now go to the **Work Plane** toolbar, deactivate Sketch visualization, and create the geometry by entering the polygon coordinates.

- 9 Click  **Go to Plane Geometry** at the top of the **Settings** window.

Work Plane 2 (wp2) > Plane Geometry

In the **Sketch** toolbar, click  **Sketch**.

Work Plane 2 (wp2) > Polygon 1 (pol1)

- 1 In the **Work Plane** toolbar, click  **Polygon**.
- 2 In the **Settings** window for **Polygon**, locate the **Coordinates** section.
- 3 In the table, enter the following settings:

xw (mm)	yw (mm)
0	0
$c_c_h-c_c_d$	0
$c_c_h-c_c_d$	$r_d/2$

xw (mm)	yw (mm)
c_c_h	r_d/2
c_c_h	0.7*r_d
c_c_h-0.8*r_d	0.7*r_d
c_c_h-0.8*r_d	c_c_r
c_c_h-1.1*r_d	c_c_r
c_c_h-1.1*r_d	c_c_r-r_d/2
0	c_c_r-r_d/2

4 Click  **Build Selected.**

Zoom and center around the polygon.

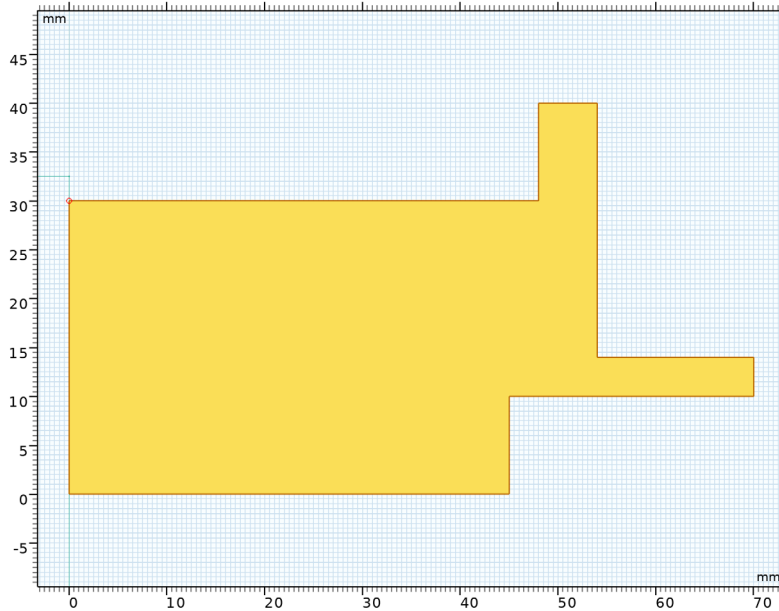

Work Plane 2 (wp2) > Fillet 1 (fil1)

Add fillets to the corners.

- 1 In the **Work Plane** toolbar, click  **Fillet.**
- 2 In the **Settings** window for **Fillet**, locate the **Radius** section.
- 3 In the **Radius** text field, type $0.3*r_d$.

4 On the object **poll**, select Points 5 and 7 only.

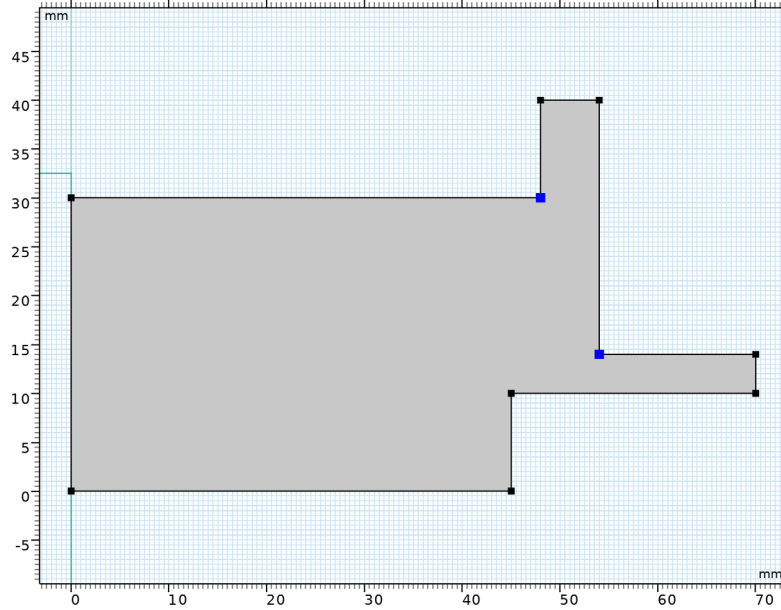

Work Plane 2 (wp2) > Fillet 2 (fil2)

- 1 In the **Work Plane** toolbar, click  **Fillet**.
- 2 In the **Settings** window for **Fillet**, locate the **Radius** section.
- 3 In the **Radius** text field, type $0.15*r_d$.

4 On the object **fill**, select Points 7 and 9 only.

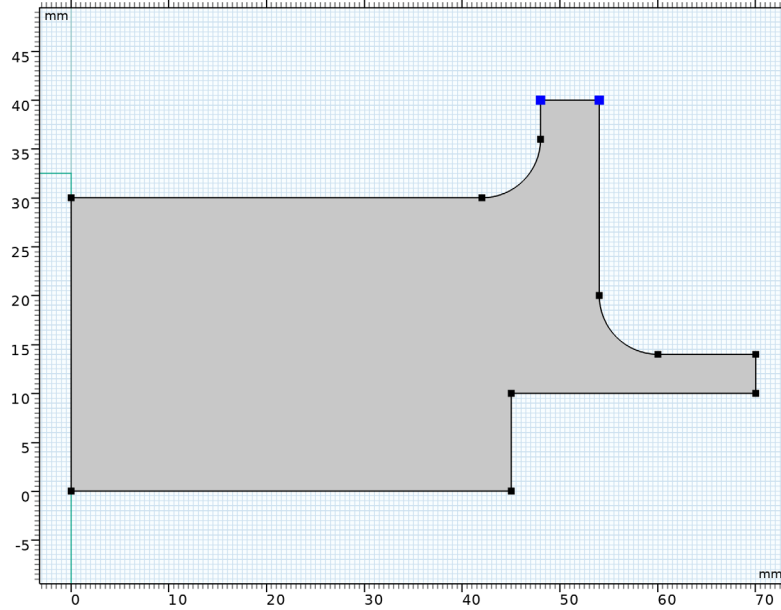

5 Click  **Build Selected**.

Revolve 1 (rev1)

1 In the **Model Builder** window, under **Component 1 (comp1)** > **Geometry 1** right-click **Work Plane 2 (wp2)** and choose **Revolve**.

2 Click the  **Zoom to Selection** button in the **Graphics** toolbar.

3 In the **Settings** window for **Revolve**, locate the **Revolution Axis** section.

4 From the **Axis type** list, choose **Edge**.

5 On the object **wp2**, select Edge 2 only.

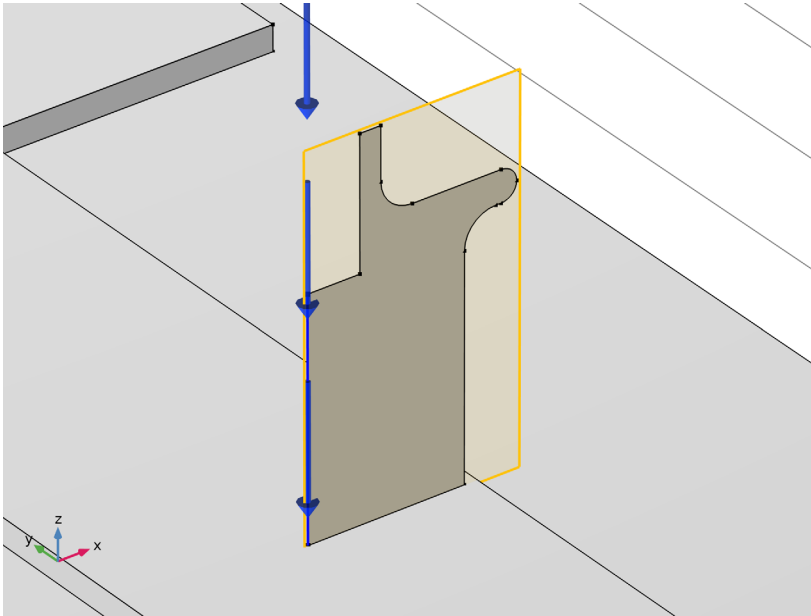

6 Locate the **Revolution Angles** section. Clear the **Keep original faces** checkbox.

7 Locate the **Selections of Resulting Entities** section. Find the **Cumulative selection** subsection. From the **Contribute to** list, choose **Titanium**.

8 Click  **Build Selected**.

- 9 Click the  **Zoom to Selection** button in the **Graphics** toolbar.

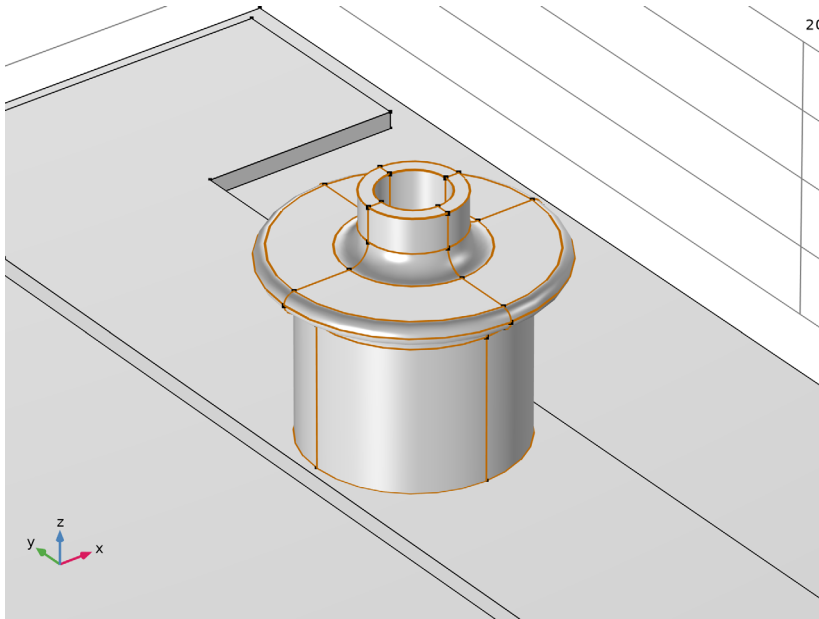

Select the features that form the central column and create a new group node.

Revolve 1 (rev1), Work Plane 2 (wp2)

- 1 In the **Model Builder** window, under **Component 1 (comp1) > Geometry 1**, Ctrl-click to select **Work Plane 2 (wp2)** and **Revolve 1 (rev1)**.
- 2 Right-click and choose **Group**.

Central Column

In the **Settings** window for **Group**, type Central Column in the **Label** text field.

Rod

- 1 In the **Geometry** toolbar, click  **Cylinder**.
- 2 In the **Settings** window for **Cylinder**, type Rod in the **Label** text field.
- 3 Locate the **Size and Shape** section. In the **Radius** text field, type $r_d/2$.
- 4 In the **Height** text field, type r_1 .
- 5 Locate the **Coordinate System** section. From the **Work plane** list, choose **Work Plane 2 (wp2)**.
- 6 Locate the **Axis** section. From the **Axis type** list, choose **xw-axis**.
- 7 Locate the **Position** section. In the **xw** text field, type $c_c_h-c_c_d$.

8 Click  **Build Selected**.

9 Click the  **Zoom to Selection** button in the **Graphics** toolbar.

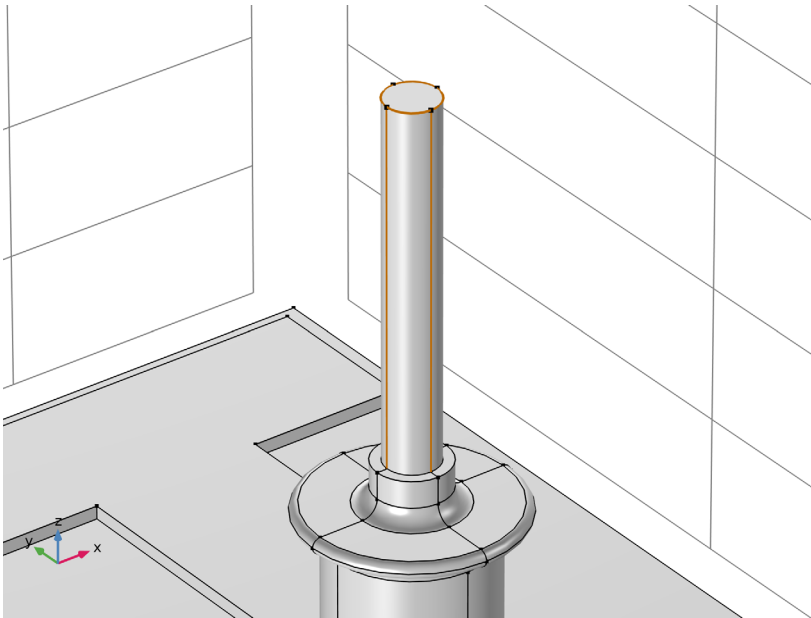

10 Right-click **Rod** and choose **Move Out**, since the rod is not part of the Central Column group.

Next we can add an empty group node. The operations following the group node will be automatically added to the group.

Rod Connector

1 In the **Model Builder** window, right-click **Geometry 1** and choose **Node Group**.

2 In the **Settings** window for **Group**, type Rod Connector in the **Label** text field.

Work Plane 3 (wp3)

1 In the **Geometry** toolbar, click  **Work Plane**.

2 In the **Settings** window for **Work Plane**, locate the **Plane Definition** section.



3 From the **Plane type** list, choose **Face parallel**.

4 On the object **cyll**, select Boundary 4 only, the top boundary of the cylinder.



5 Locate the **Local Coordinate System** section. In the **yw-displacement** text field, type $r_c_w/2-2*s_di$.

6 Click  **Go to Plane Geometry**.

Work Plane 3 (wp3) > Cross Section 1 (cro1)

- 1 In the **Work Plane** toolbar, click  **Cross Section**.
- 2 In the **Settings** window for **Cross Section**, locate the **Cross Section** section.
- 3 From the **Intersect** list, choose **Selected objects**.
- 4 Select the object **cyll** only.
- 5 Click  **Build Selected**.

Work Plane 3 (wp3) > Rectangle 1 (r1)

- 1 In the **Work Plane** toolbar, click  **Rectangle**.
- 2 In the **Settings** window for **Rectangle**, locate the **Size and Shape** section.
- 3 In the **Width** text field, type a_c_w.
- 4 In the **Height** text field, type r_c_w.
- 5 Locate the **Position** section. From the **Base** list, choose **Center**.
- 6 Click  **Build Selected**.

Zoom in on the rectangle for a better view.

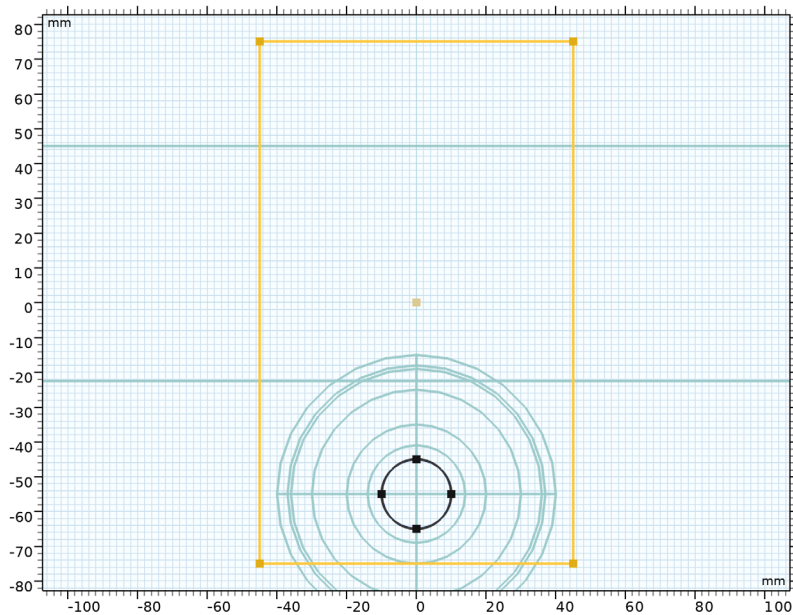

Work Plane 3 (wp3) > Fillet 1 (fil1)



- 1 In the **Work Plane** toolbar, click  **Fillet**.

Round all corners of the rectangle.

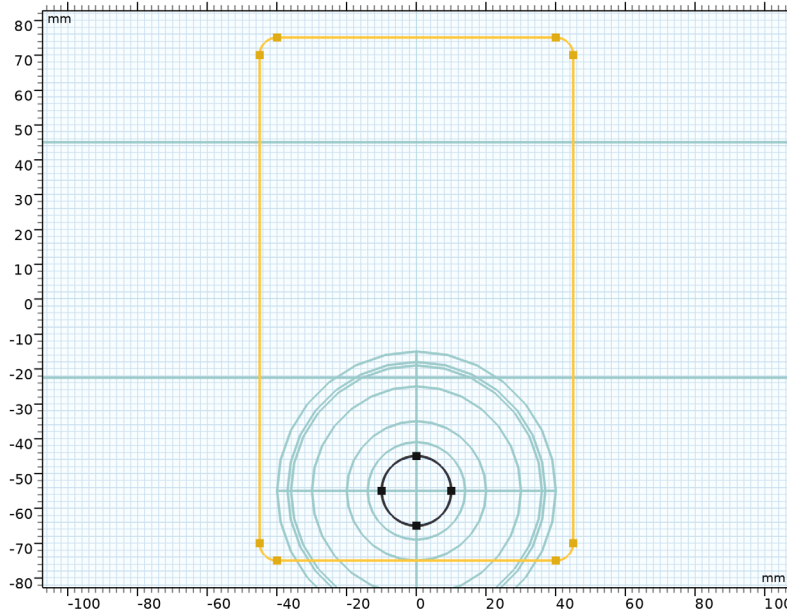
- 2 In the **Settings** window for **Fillet**, locate the **Radius** section.
- 3 In the **Radius** text field, type 5[mm].
- 4 On the object **r1**, select Points 1–4 only.
- 5 Click  **Build Selected**.



Work Plane 3 (wp3) > Difference 1 (dif1)

- 1 In the **Work Plane** toolbar, click  **Booleans and Partitions** and choose **Difference**.
Subtract the cross section of the rod from the rectangle.
- 2 Select the object **fill** only.
- 3 In the **Settings** window for **Difference**, locate the **Difference** section.
- 4 Click to select the  **Activate Selection** toggle button for **Objects to subtract**.
- 5 Select the object **cro1** only.

6 Click  **Build Selected.**

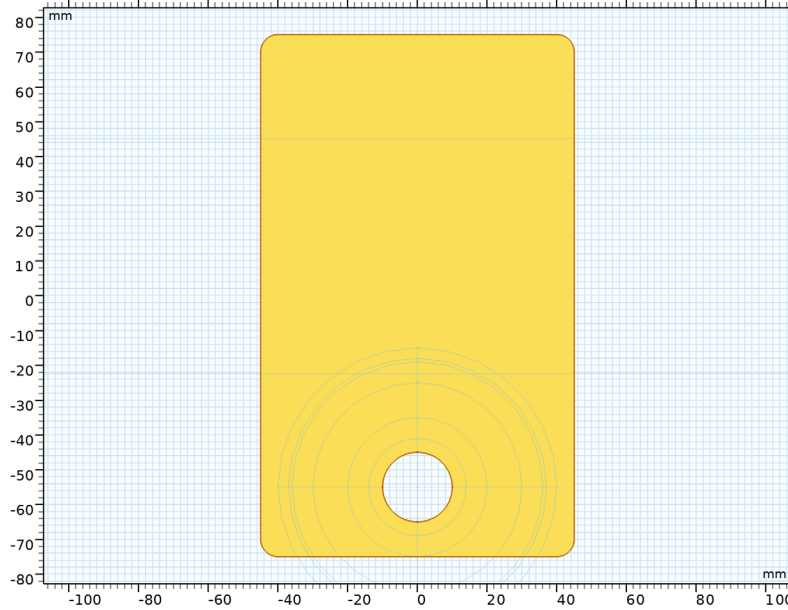

Extrude 2 (ext2)

- 1 In the **Model Builder** window, under **Component 1 (comp1) > Geometry 1 > Rod Connector** right-click **Work Plane 3 (wp3)** and choose **Extrude**.
- 2 In the **Settings** window for **Extrude**, locate the **Distances** section.
- 3 In the table, enter the following settings:

Distances (mm)
r_c_h

- 4 Select the **Reverse direction** checkbox.
- 5 Click  **Build Selected.**

6 Click the  **Zoom to Selection** button in the **Graphics** toolbar.

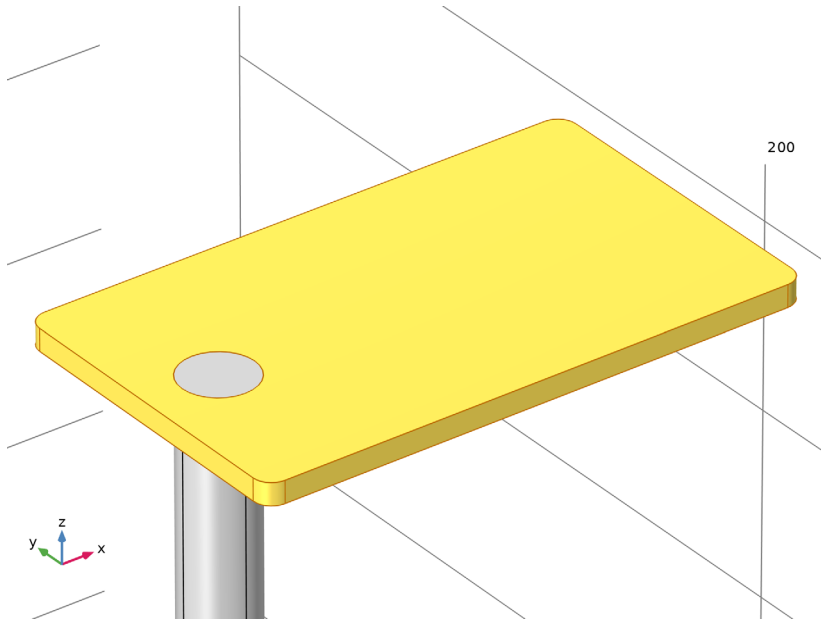

7 Click **Geometry I** to leave the group node.

Array 1 (arr1)

Create a symmetrical pattern with four entities from the objects you have built so far.

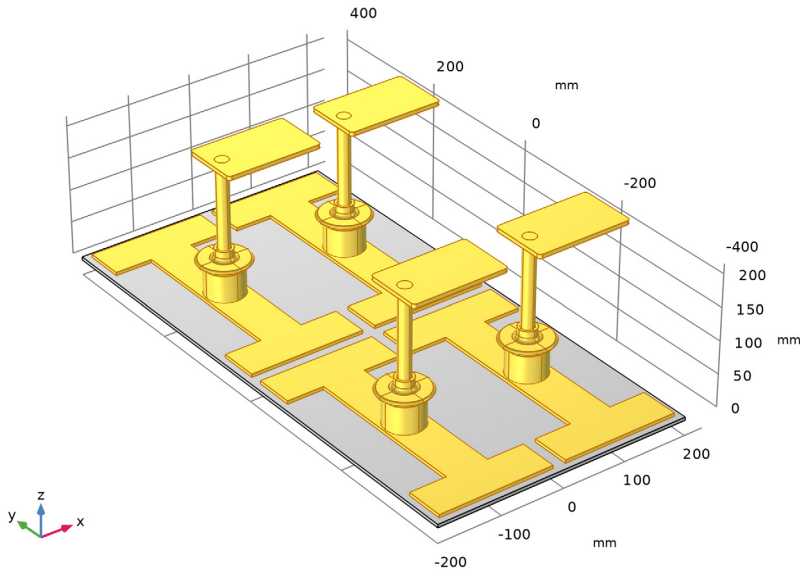

- 1 In the **Geometry** toolbar, click  **Transforms** and choose **Array**.
- 2 Select the objects **cyll**, **ext1**, **ext2**, and **rev1** only.
- 3 In the **Settings** window for **Array**, locate the **Size** section.
- 4 In the **x size** text field, type 2.
- 5 In the **y size** text field, type 2.
- 6 Locate the **Displacement** section. In the **x** text field, type $-c_g_w/2$.
- 7 In the **y** text field, type $-c_g_1/2$.

8 Click  **Build Selected.**



Work Plane 4 (wp4)

Continue with creating the geometry for the elbow connector.

- 1 In the **Geometry** toolbar, click  **Work Plane**.
- 2 In the **Settings** window for **Work Plane**, locate the **Plane Definition** section.
- 3 In the **z-coordinate** text field, type $c_g_h+s_h+c_c_h-c_c_d+r_1$.
- 4 Locate the **Local Coordinate System** section. In the **xw-displacement** text field, type $c_g_w/4-3*b_di+r_c_w$.
- 5 In the **yw-displacement** text field, type $c_g_l/4-a_c_w/2$.
- 6 Click  **Go to Plane Geometry** at the top of the **Settings** window.

Work Plane 4 (wp4) > Plane Geometry



Go to the **Work Plane** toolbar and define a rectangle by its width and height.

Work Plane 4 (wp4) > Rectangle 1 (r1)

- 1 In the **Work Plane** toolbar, click  **Rectangle**.
- 2 In the **Settings** window for **Rectangle**, locate the **Size and Shape** section.
- 3 In the **Width** text field, type e_c_lx .

4 In the **Height** text field, type `a_c_w`.

Work Plane 4 (wp4) > Fillet 1 (fil1)

- 1 In the **Work Plane** toolbar, click  **Fillet**.
- 2 On the object **r1**, select Points 1 and 4 only.
- 3 In the **Settings** window for **Fillet**, locate the **Radius** section.
- 4 In the **Radius** text field, type `5[mm]`.
- 5 Click  **Build Selected**.
- 6 Click the  **Zoom Extents** button in the **Graphics** toolbar.



Extrude 3 (ext3)

- 1 In the **Model Builder** window, under **Component 1 (comp1) > Geometry 1** right-click **Work Plane 4 (wp4)** and choose **Extrude**.
- 2 In the **Settings** window for **Extrude**, locate the **Distances** section.
- 3 In the table, enter the following settings:

Distances (mm)
<code>e_c_h</code>

- 4 Click  **Build Selected**.

Work Plane 5 (wp5)

- 1 In the **Geometry** toolbar, click  **Work Plane**.
- 2 In the **Settings** window for **Work Plane**, locate the **Plane Definition** section.
- 3 From the **Plane** list, choose **yz-plane**.
- 4 In the **x-coordinate** text field, type `c_g_w/4-3*b_di+r_c_w+e_c_lx+2*e_c_h`.
- 5 Locate the **Local Coordinate System** section. In the **xw-displacement** text field, type `c_g_l/4-a_c_w/2`.
- 6 In the **yw-displacement** text field, type `c_g_h+s_h+c_c_h-c_c_d+r_l+2*e_c_h`.
- 7 Click  **Go to Plane Geometry** at the top of the **Settings** window.

Work Plane 5 (wp5) > Plane Geometry



Go to the **Work Plane** toolbar and define a rectangle by its width and height.

Work Plane 5 (wp5) > Rectangle 1 (r1)

- 1 In the **Work Plane** toolbar, click  **Rectangle**.
- 2 In the **Settings** window for **Rectangle**, locate the **Size and Shape** section.
- 3 In the **Width** text field, type `a_c_w`.

4 In the **Height** text field, type e_c_1z .

Work Plane 5 (wp5) > Fillet 1 (fil1)

- 1 In the **Work Plane** toolbar, click  **Fillet**.
- 2 On the object **r1**, select Points 3 and 4 only.
- 3 In the **Settings** window for **Fillet**, locate the **Radius** section.
- 4 In the **Radius** text field, type 5[mm].
- 5 Click  **Build Selected**.



Extrude 4 (ext4)

- 1 In the **Model Builder** window, under **Component 1 (comp1) > Geometry 1** right-click **Work Plane 5 (wp5)** and choose **Extrude**.
- 2 In the **Settings** window for **Extrude**, locate the **Distances** section.
- 3 In the table, enter the following settings:



Distances (mm)
e_c_h

- 4 Select the **Reverse direction** checkbox.
- 5 Click  **Build Selected**.

Work Plane 6 (wp6)

- 1 In the **Geometry** toolbar, click  **Work Plane**.
- 2 In the **Settings** window for **Work Plane**, locate the **Plane Definition** section.
- 3 From the **Plane** list, choose **xz-plane**.
- 4 Locate the **Local Coordinate System** section. In the **xw-displacement** text field, type $c_g_w/4-3*b_di+r_c_w+e_c_1x$.
- 5 In the **yw-displacement** text field, type $c_g_h+s_h+c_c_h-c_c_d+r_1+2*e_c_h$.
- 6 Click  **Go to Plane Geometry** at the top of the **Settings** window.

Work Plane 6 (wp6) > Circle 1 (c1)

- 1 In the **Work Plane** toolbar, click  **Circle**.
- 2 In the **Settings** window for **Circle**, locate the **Size and Shape** section.
- 3 In the **Radius** text field, type e_c_h .
- 4 In the **Sector angle** text field, type 90.
- 5 Locate the **Rotation Angle** section. In the **Rotation** text field, type 270.
- 6 Click  **Build Selected**.

Work Plane 6 (wp6) > Circle 2 (c2)

1 Right-click **Component 1 (comp1) > Geometry 1 > Work Plane 6 (wp6) > Plane Geometry > Circle 1 (c1)** and choose **Duplicate**.

2 In the **Settings** window for **Circle**, locate the **Size and Shape** section.

3 In the **Radius** text field, type e_c_h*2 .

4 Click  **Build Selected**.

Work Plane 6 (wp6) > Plane Geometry

In the **Model Builder** window, click **Plane Geometry**.

Work Plane 6 (wp6) > Difference 1 (dif1)

1 In the **Work Plane** toolbar, click  **Booleans and Partitions** and choose **Difference**.

The **Objects to add** subsection is activated by default. Add the objects on which the operation is to be performed.

2 Select the object **c2** only.

3 In the **Settings** window for **Difference**, locate the **Difference** section.

4 Click to select the  **Activate Selection** toggle button for **Objects to subtract**.

5 Select the object **c1** only.

6 Click  **Build Selected**.

- 7 Click the  **Zoom to Selection** button in the **Graphics** toolbar.

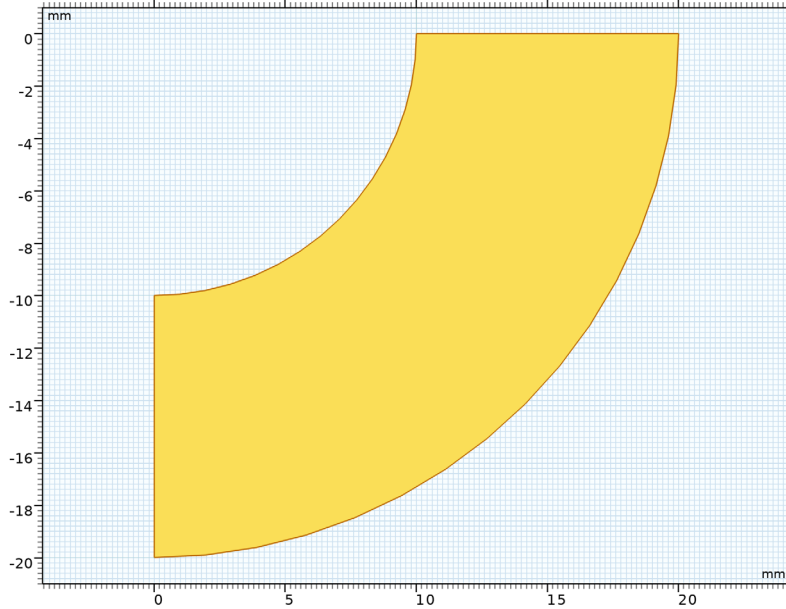

Extrude 5 (ext5)

- 1 In the **Model Builder** window, under **Component 1 (comp1)** > **Geometry 1** right-click **Work Plane 6 (wp6)** and choose **Extrude**.
- 2 In the **Settings** window for **Extrude**, locate the **Distances** section.
- 3 From the **Specify** list, choose **Vertices to extrude to**.

Define the vertices to extrude between. Adjust the view according to the next image to make the selection easier.

4 On the object **ext3**, select Points 10 and 12 only.

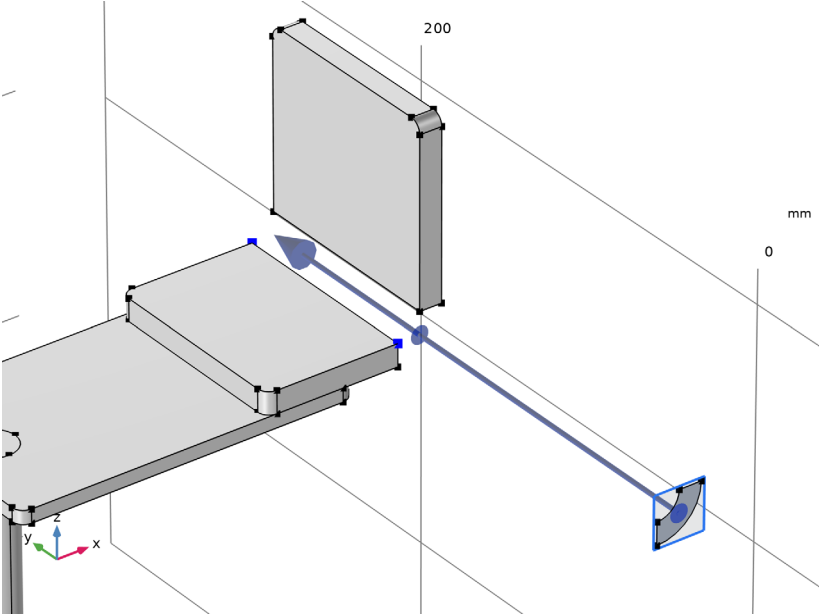

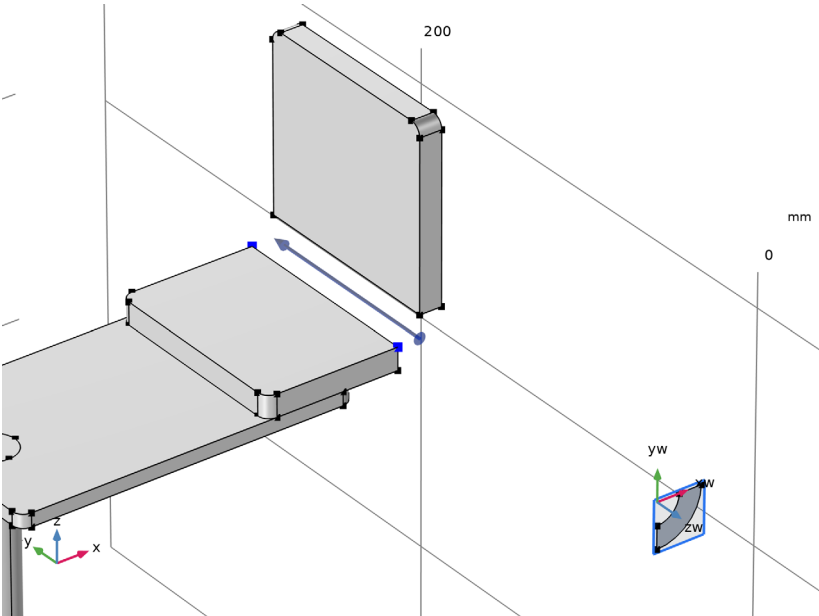

5 Clear the **Include input entities** checkbox to exclude the face from the extrusion.



6 Click  **Build Selected**.

Union 1 (uni1)

- 1 In the **Geometry** toolbar, click  **Booleans and Partitions** and choose **Union**.
- 2 Select the objects **ext3**, **ext4**, and **ext5** only.
- 3 In the **Settings** window for **Union**, locate the **Union** section.
- 4 Clear the **Keep interior boundaries** checkbox.
- 5 Click  **Build Selected**.

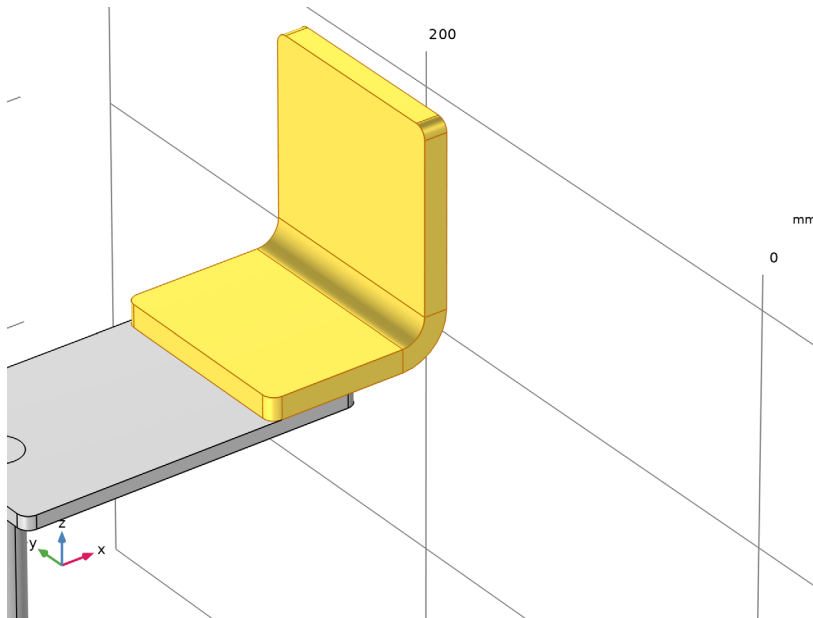

Elbow Connector

- 1 In the **Model Builder** window, right-click **Geometry 1** and choose **Node Group**.
- 2 In the **Settings** window for **Group**, type **Elbow Connector** in the **Label** text field.
- 3 In the **Model Builder** window, under **Component 1 (comp1) > Geometry 1**, Ctrl-click to select **Work Plane 4 (wp4)**, **Extrude 3 (ext3)**, **Work Plane 5 (wp5)**, **Extrude 4 (ext4)**, **Work Plane 6 (wp6)**, **Extrude 5 (ext5)**, and **Union 1 (uni1)**.
- 4 Right-click and choose **Move To > Elbow Connector**.
- 5 In the **Geometry** toolbar, click  **Work Plane**.

Work Plane 7 (wp7)

- 1 In the **Settings** window for **Work Plane**, locate the **Plane Definition** section.

- 2 From the **Plane** list, choose **zx-plane**.
- 3 In the **y-coordinate** text field, type $c_g_l/4 - a_c_w/2$.
- 4 Locate the **Local Coordinate System** section. In the **xw-displacement** text field, type $c_g_h + s_h + c_c_h - c_c_d + r_l$.
- 5 In the **yw-displacement** text field, type $-c_g_w/4 - b_di * 3 + r_c_w$.
- 6 Right-click **Work Plane 7 (wp7)** and choose **Move Out**.

Work Plane 7 (wp7) > Plane Geometry

- 1 In the **Model Builder** window, expand the **Work Plane 7 (wp7)** node, then click **Plane Geometry**.
- 2 In the **Work Plane** toolbar, click  **Sketch**.

Work Plane 7 (wp7) > Polygon 1 (pol1)

- 1 In the **Work Plane** toolbar, click  **Polygon**.
- 2 In the **Settings** window for **Polygon**, locate the **Coordinates** section.
- 3 In the table, enter the following settings:

xw (mm)	yw (mm)
0	0
0	60[mm]
e_c_h	90[mm]
e_c_h	$c_g_w/2 + b_di * 2$
e_c_h + a_c_h	$c_g_w/2 + b_di * 2$
e_c_h + a_c_h	90[mm]
a_c_h	60[mm]
a_c_h	0

4 Click  **Build Selected.**

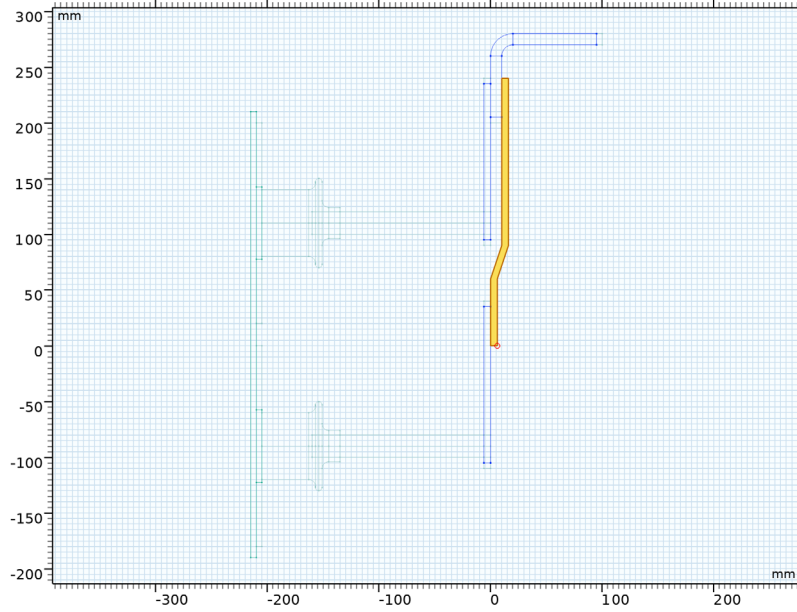

Work Plane 7 (wp7) > Plane Geometry

Add **Fillet**s to some of the corners. First, zoom in to the region of the bend on the cross section.

Work Plane 7 (wp7) > Fillet 1 (fil1)

I In the **Work Plane** toolbar, click  **Fillet.**

2 On the object **poll**, select Points 2 and 7 only.

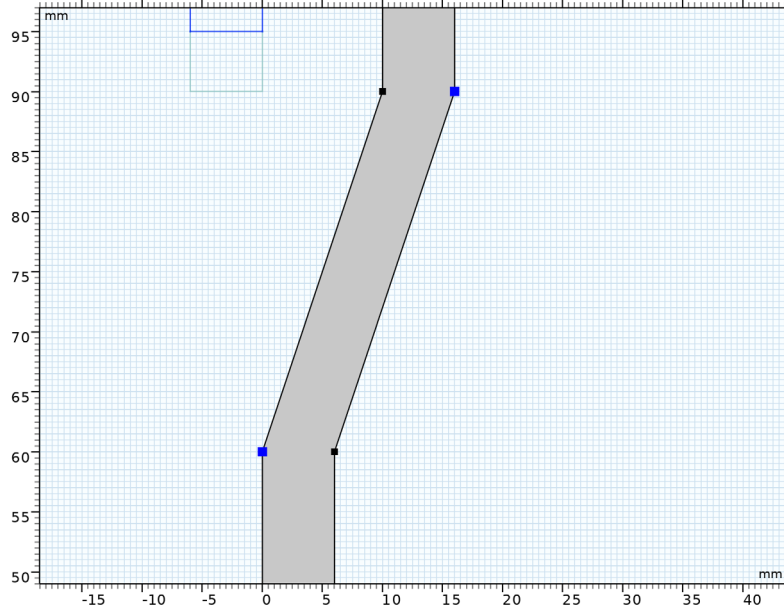

3 In the **Settings** window for **Fillet**, locate the **Radius** section.

4 In the **Radius** text field, type 20 [mm].

Work Plane 7 (wp7) > Fillet 2 (fil2)

1 In the **Work Plane** toolbar, click  **Fillet**.

2 On the object **fill**, select Points 5 and 6 only.

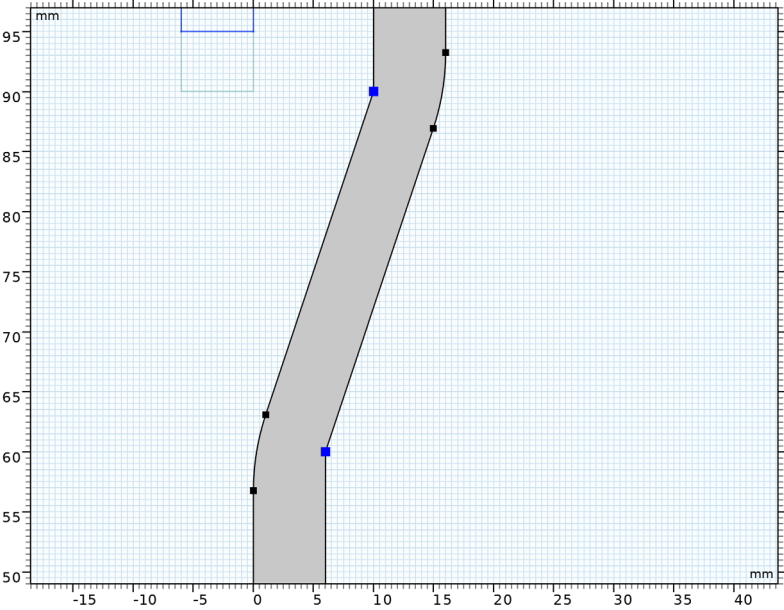

3 In the **Settings** window for **Fillet**, locate the **Radius** section.

4 In the **Radius** text field, type 20[mm] -a_c_h.

5 Click  **Build Selected.**

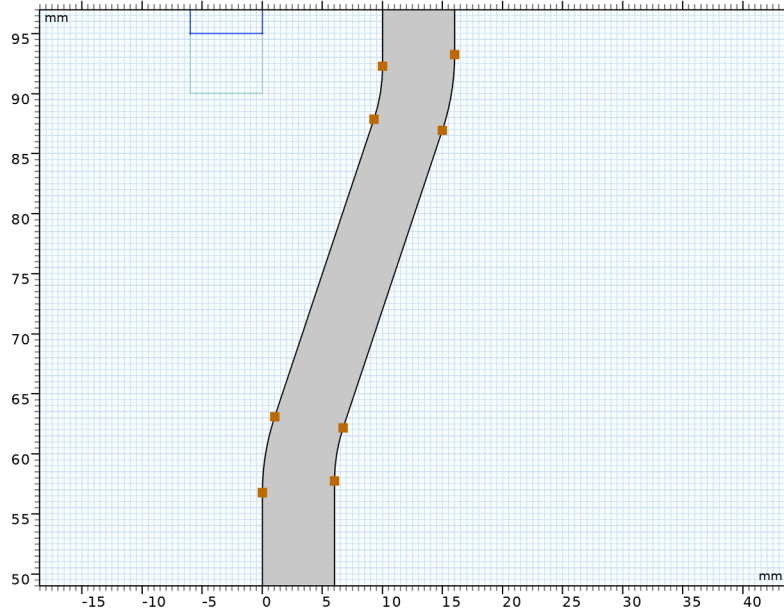

Extrude 6 (ext6)

- 1 In the **Model Builder** window, under **Component 1 (comp1)** > **Geometry 1** right-click **Work Plane 7 (wp7)** and choose **Extrude**.
- 2 In the **Settings** window for **Extrude**, locate the **Distances** section.
- 3 In the table, enter the following settings:



Distances (mm)
a_c_w

4 Click  **Build Selected.**

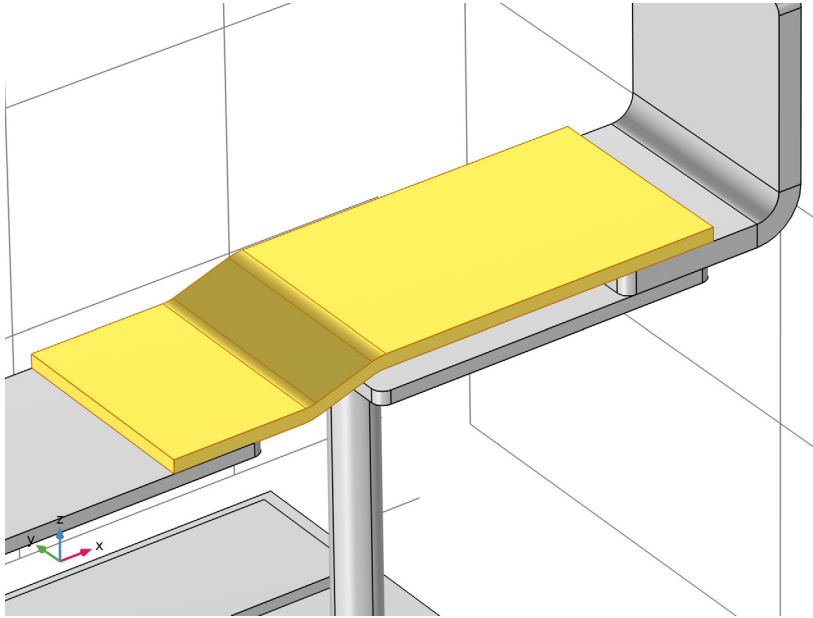
- 5 Click the  **Zoom to Selection** button in the **Graphics** toolbar.





Work Plane 8 (wp8)

- 1 In the **Geometry** toolbar, click  **Work Plane**.
- 2 In the **Settings** window for **Work Plane**, locate the **Plane Definition** section.
- 3 In the **z-coordinate** text field, type $c_g_h+s_h+c_c_h-c_c_d+r_1$.
- 4 Locate the **Local Coordinate System** section. In the **xw-displacement** text field, type $-c_g_w/4-b_di*3+r_c_w$.
- 5 In the **yw-displacement** text field, type $c_g_w/2-a_c_w/2$.
- 6 Click  **Go to Plane Geometry** at the top of the **Settings** window.

Work Plane 8 (wp8) > Plane Geometry

Go to the **Work Plane** toolbar and define a rectangle by its width and height.

Work Plane 8 (wp8) > Rectangle 1 (r1)

- 1 In the **Work Plane** toolbar, click  **Rectangle**.
- 2 In the **Settings** window for **Rectangle**, locate the **Size and Shape** section.
- 3 In the **Width** text field, type $c_g_w/2+b_di*2$.
- 4 In the **Height** text field, type a_c_w .
- 5 Click  **Build Selected**.

6 Click the  **Zoom Extents** button in the **Graphics** toolbar.

Work Plane 8 (wp8) > Fillet 1 (fil1)

1 In the **Work Plane** toolbar, click  **Fillet**.

2 Click the  **Select All** button in the **Graphics** toolbar.

3 On the object **r1**, select Points 1–4 only.

4 In the **Settings** window for **Fillet**, locate the **Radius** section.

5 In the **Radius** text field, type 5[mm].

6 Click  **Build Selected**.

Extrude 7 (ext7)

1 In the **Model Builder** window, under **Component 1 (comp1) > Geometry 1** right-click **Work Plane 8 (wp8)** and choose **Extrude**.

2 In the **Settings** window for **Extrude**, locate the **Distances** section.

3 In the table, enter the following settings:



Distances (mm)

2*e_c_h

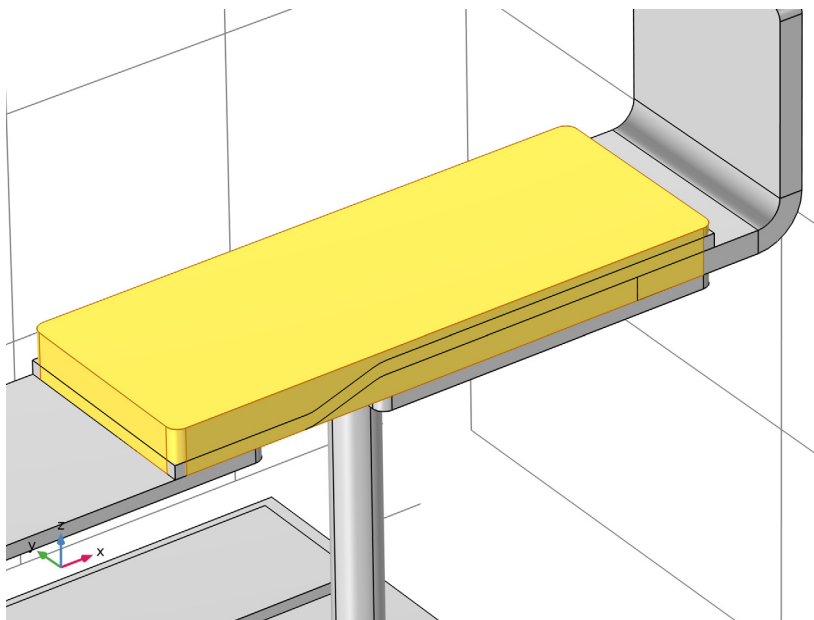
4 Click  **Build Selected**.



Intersection 1 (int1)

- 1 In the **Geometry** toolbar, click  **Booleans and Partitions** and choose **Intersection**.
- 2 Select the objects **ext6** and **ext7** only.
- 3 In the **Settings** window for **Intersection**, click  **Build Selected**.

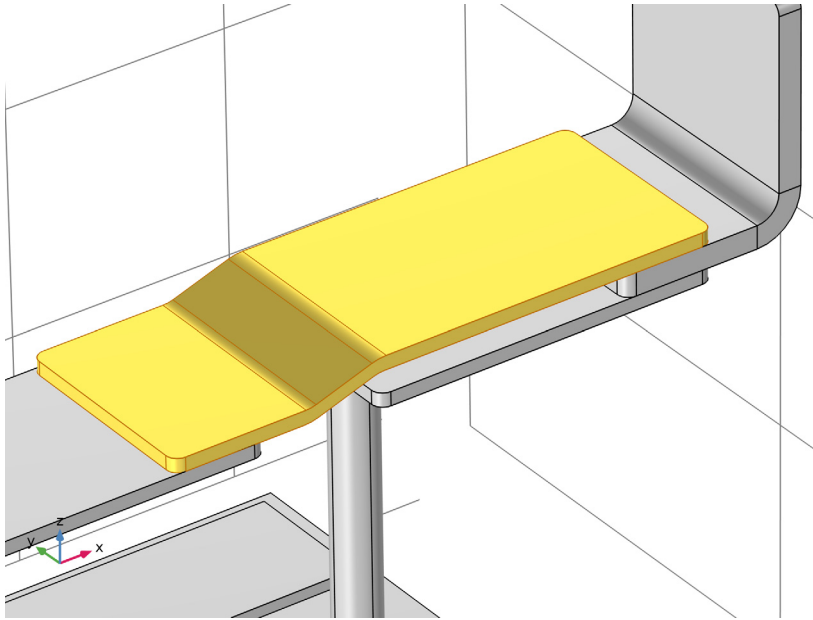



Angle Connector

- 1 In the **Model Builder** window, right-click **Geometry 1** and choose **Node Group**.
- 2 In the **Settings** window for **Group**, type Angle Connector in the **Label** text field.
- 3 In the **Model Builder** window, under **Component 1 (comp1) > Geometry 1**, Ctrl-click to select **Work Plane 7 (wp7)**, **Extrude 6 (ext6)**, **Work Plane 8 (wp8)**, **Extrude 7 (ext7)**, and **Intersection 1 (int1)**.
- 4 Right-click and choose **Move To > Angle Connector**.
- 5 In the **Geometry** toolbar, click  **Block**.

Intercell Busbar

- 1 In the **Settings** window for **Block**, type Intercell Busbar in the **Label** text field.
- 2 Locate the **Size and Shape** section. In the **Width** text field, type `i_b_h`.
- 3 In the **Depth** text field, type `i_b_l`.
- 4 In the **Height** text field, type `i_b_w`.

- 5 Locate the **Position** section. From the **Base** list, choose **Center**.
- 6 In the **x** text field, type $-c_g_1/4+a_c_w/2$.
- 7 In the **y** text field, type $i_b_w/2$.
- 8 In the **z** text field, type $i_b_h/2$.
- 9 Locate the **Coordinate System** section. From the **Work plane** list, choose **Work Plane 5 (wp5)**.
- 10 Locate the **Axis** section. From the **Axis type** list, choose **yw-axis**.
- 11 Right-click **Component 1 (comp1) > Geometry 1 > Angle Connector > Intercell Busbar** and choose **Move Out**.
- 12 In the **Model Builder** window, click **Intercell Busbar (blk2)**.
- 13 Click  **Build Selected**.
- 14 Click the  **Zoom Extents** button in the **Graphics** toolbar.

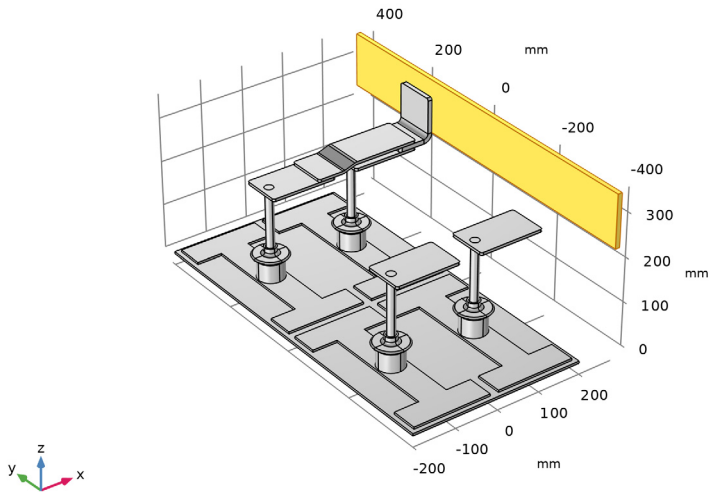

Bolt Short

- 1 In the **Geometry** toolbar, click  **Cylinder**.
- 2 In the **Settings** window for **Cylinder**, type Bolt Short in the **Label** text field.
- 3 Locate the **Size and Shape** section. In the **Radius** text field, type b_r .
- 4 In the **Height** text field, type $r_c_h+a_c_h$.

- 5 Locate the **Coordinate System** section. From the **Work plane** list, choose **Work Plane 8 (wp8)**. We can now define the position of the cylinder relative to the origin of the selected work plane.

Zoom in near the origin of the selected work plane.

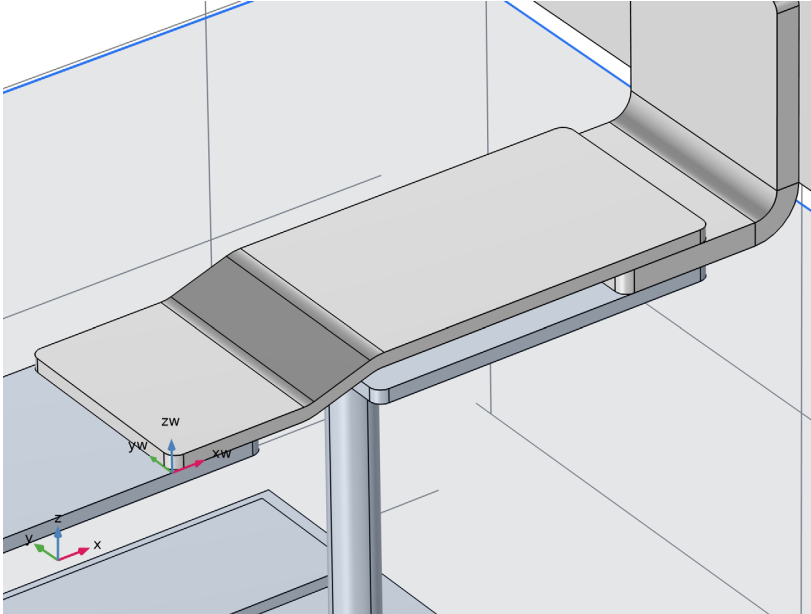

- 6 Locate the **Position** section. In the **xw** text field, type `b_di`.
- 7 In the **yw** text field, type `a_c_w/4`.
- 8 In the **zw** text field, type `-r_c_h`.
- 9 Locate the **Selections of Resulting Entities** section. Find the **Cumulative selection** subsection. From the **Contribute to** list, choose **Titanium**.

10 Click  **Build Selected.**

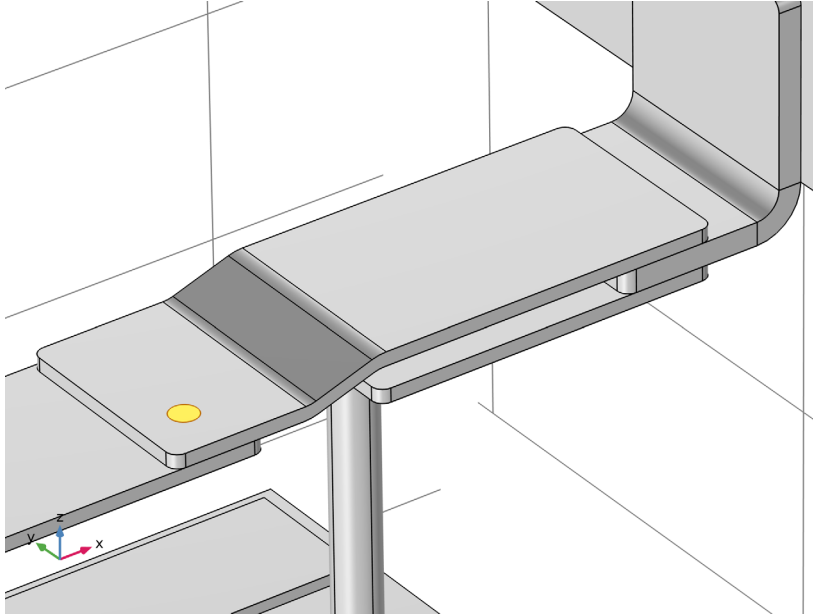



Bolt Long

- 1 In the **Geometry** toolbar, click  **Cylinder**.
- 2 In the **Settings** window for **Cylinder**, type Bolt Long in the **Label** text field.
- 3 Locate the **Size and Shape** section. In the **Radius** text field, type b_r .
- 4 In the **Height** text field, type $r_c_h + a_c_h + e_c_h$.
- 5 Locate the **Coordinate System** section. From the **Work plane** list, choose **Work Plane 4 (wp4)**.
- 6 Locate the **Position** section. In the **xw** text field, type b_{di} .
- 7 In the **yw** text field, type $a_c_w / 4$.
- 8 In the **zw** text field, type $-r_c_h$.
- 9 Locate the **Selections of Resulting Entities** section. Find the **Cumulative selection** subsection. From the **Contribute to** list, choose **Titanium**.

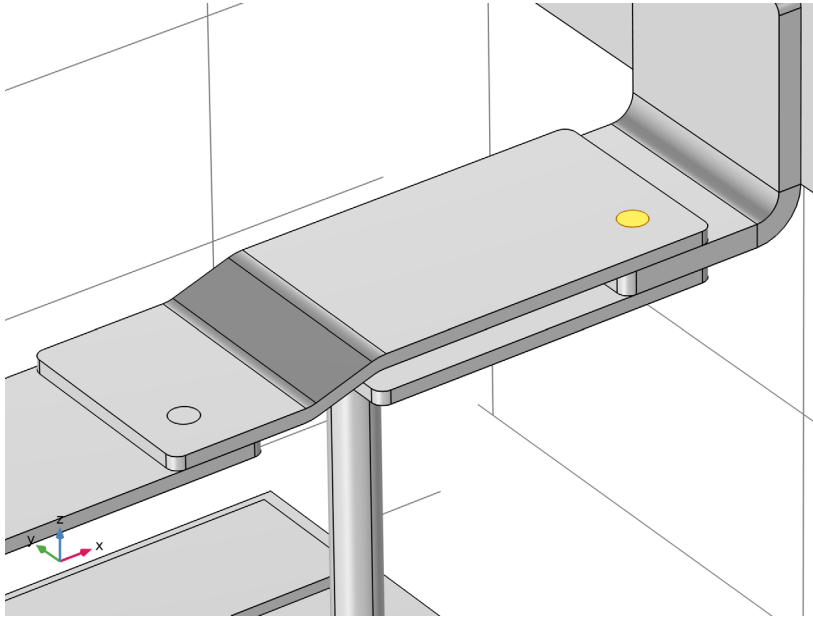
10 Click  **Build Selected.**



Bolt Medium

- 1 In the **Geometry** toolbar, click  **Cylinder.**
- 2 In the **Settings** window for **Cylinder**, type Bolt Medium in the **Label** text field.
- 3 Locate the **Size and Shape** section. In the **Radius** text field, type b_r .
- 4 In the **Height** text field, type $e_c_{h+i}_{b_h}$.
- 5 Locate the **Coordinate System** section. From the **Work plane** list, choose **Work Plane 5 (wp5)**.
- 6 Locate the **Position** section. In the **xw** text field, type $a_c_w/4$.
- 7 In the **yw** text field, type b_{di} .
- 8 In the **zw** text field, type $-e_c_h$.
- 9 Locate the **Selections of Resulting Entities** section. Find the **Cumulative selection** subsection. From the **Contribute to** list, choose **Titanium**.
- 10 Click  **Build Selected.**

II Zoom out as needed to see the bolt on the canvas.

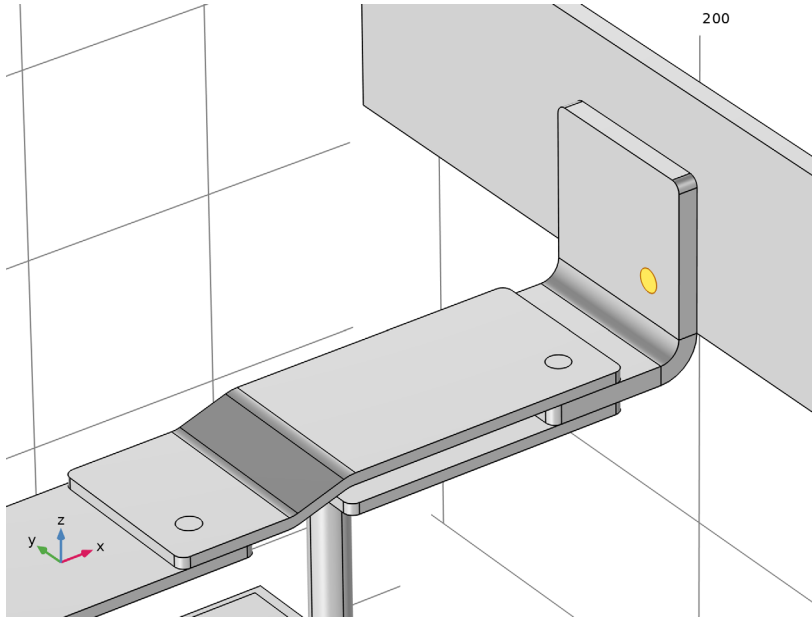

Move 1 (mov1)

- 1 In the **Geometry** toolbar, click  **Transforms** and choose **Move**.
- 2 Select the object **cyl4** only.
- 3 In the **Settings** window for **Move**, locate the **Input** section.
- 4 Select the **Keep input objects** checkbox.
- 5 Locate the **Displacement** section. In the **z** text field, type 40[mm].

Mirror 1 (mir1)

- 1 In the **Geometry** toolbar, click  **Transforms** and choose **Mirror**.
- 2 Select the objects **cyl2**, **cyl3**, **cyl4**, and **mov1** only.
- 3 In the **Settings** window for **Mirror**, locate the **Input** section.
- 4 Select the **Keep input objects** checkbox.
- 5 Locate the **Normal Vector to Plane of Reflection** section. In the **y** text field, type 1.
- 6 In the **z** text field, type 0.
- 7 Locate the **Point on Plane of Reflection** section. In the **y** text field, type **c_g_1/4**.

8 Click  **Build Selected.**

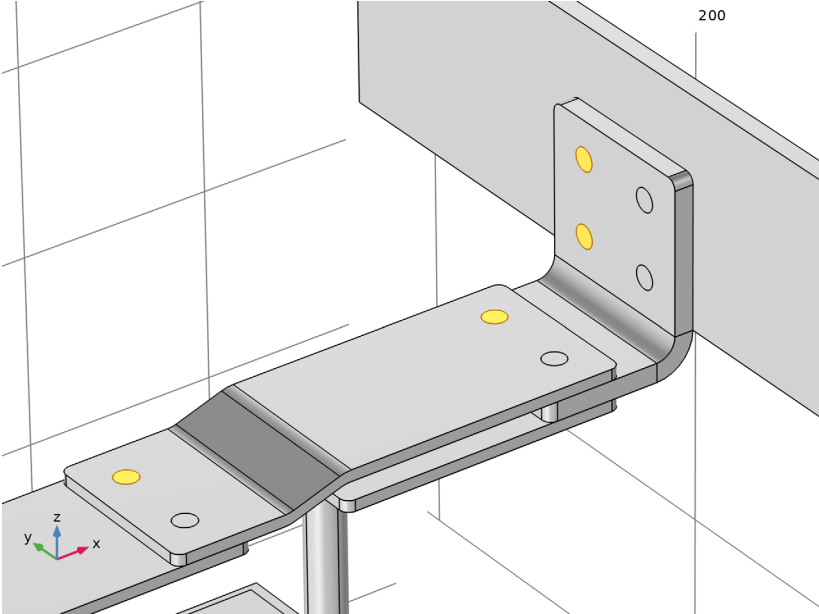

Move 2 (mov2)

1 In the **Geometry** toolbar, click  **Transforms** and choose **Move**.

- 2 Select the objects **cyl2**, **cyl3**, **cyl4**, **int1**, **mir1(1)**, **mir1(2)**, **mir1(3)**, **mir1(4)**, **mov1**, and **uni1** only.

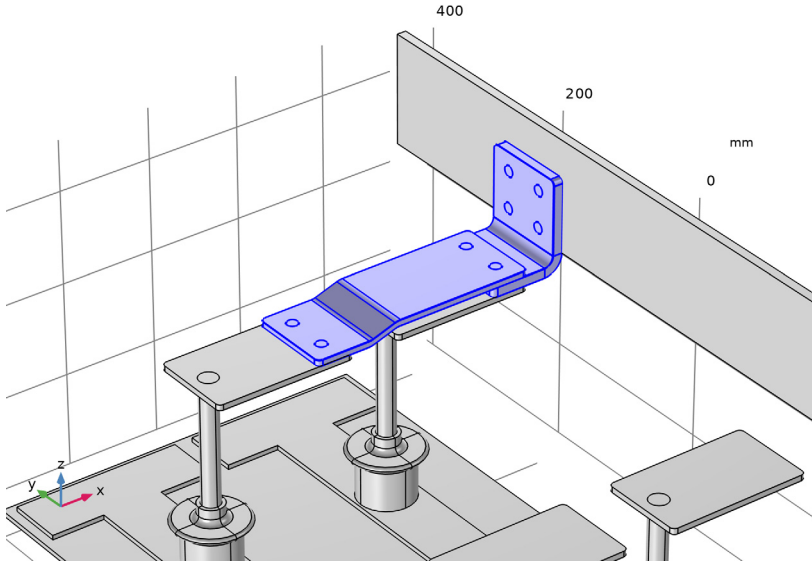

- 3 In the **Model Builder** window, click **Move 2 (mov2)**.

- 4 In the **Settings** window for **Move**, locate the **Input** section.

- 5 Select the **Keep input objects** checkbox.

A displacement can also be defined by vertices. The starting point and destination points do not have to be located inside the object to be moved.

- 6 Locate the **Displacement** section. From the **Specify** list, choose **Positions**.

- 7 Click to select the **Activate Selection** toggle button for **Vertex to move**.

Select one vertex on the rod.

8 On the object **arr1(2,1,1,3)**, select Point 10 only.

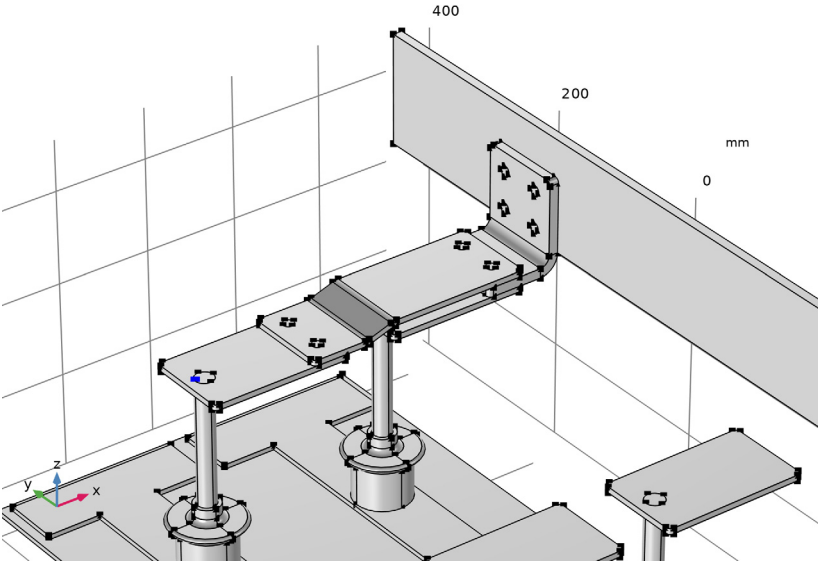

9 Click to select the **Activate Selection** toggle button for **Vertices to move to**.

10 On the object **arr1(2,2,1,3)**, select Point 10 only.

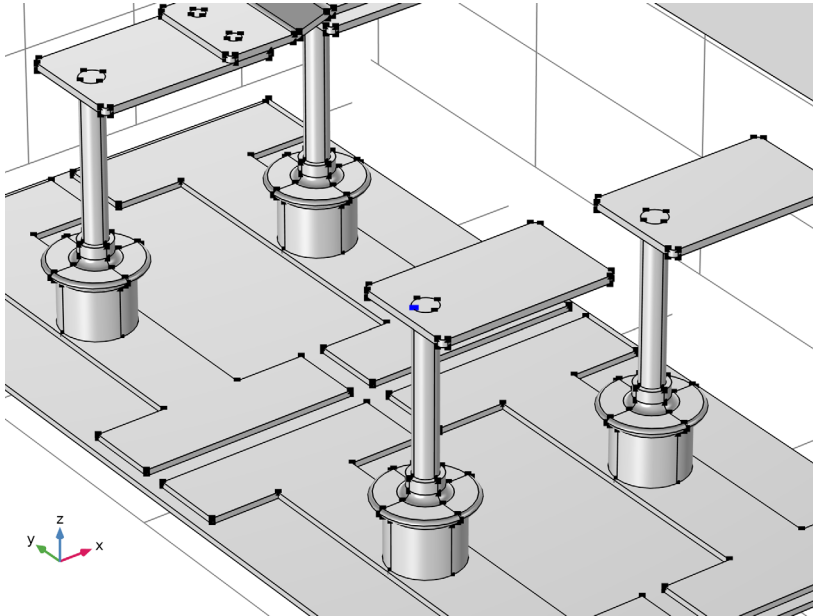

Form Union (fin)

1 In the **Model Builder** window, click **Form Union (fin)**.

- 2 In the **Settings** window for **Form Union/Assembly**, click  **Build Selected**.

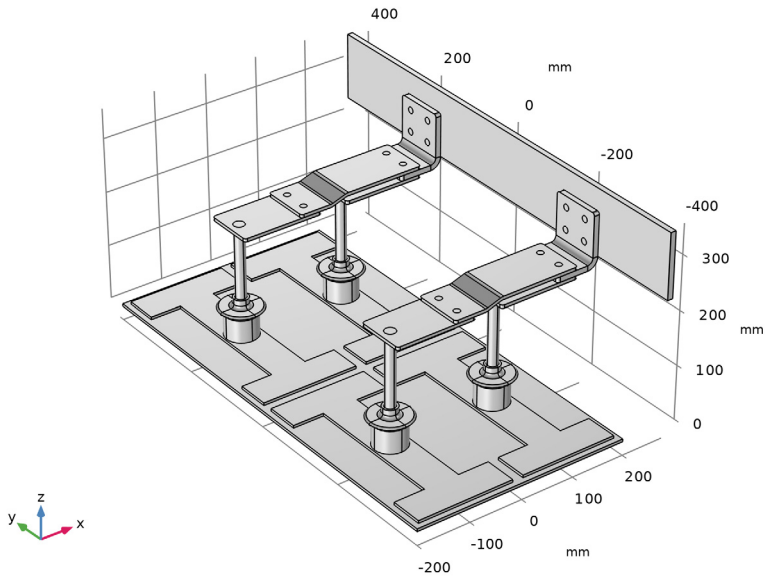

Copper

In the following we will set up selections to streamline the material and physics setup.

- 1 In the **Geometry** toolbar, click  **Selections** and choose **Complement Selection**.
- 2 In the **Settings** window for **Complement Selection**, type Copper in the **Label** text field.
- 3 Locate the **Input Entities** section. Click **+ Add**.
- 4 In the **Add** dialog, select **Titanium** in the **Selections to invert** list.
- 5 Click **OK**.

Adjacent Selection I (adjsel1)

- 1 In the **Geometry** toolbar, click  **Selections** and choose **Adjacent Selection**.
- 2 In the **Settings** window for **Adjacent Selection**, locate the **Input Entities** section.
- 3 Click **+ Add**.
- 4 In the **Add** dialog, in the **Input selections** list, choose **Titanium** and **Copper**.
- 5 Click **OK**.
- 6 In the **Settings** window for **Adjacent Selection**, locate the **Resulting Selection** section.
- 7 From the **Show in physics** list, choose **Off**.

Electrolyte Boundary

- 1 In the **Geometry** toolbar, click  **Selections** and choose **Explicit Selection**.
- 2 In the **Settings** window for **Explicit Selection**, type Electrolyte Boundary in the **Label** text field.
- 3 Locate the **Entities to Select** section. From the **Geometric entity level** list, choose **Boundary**.
- 4 On the object **fin**, select Boundary 3 only, the bottom of the Cell Grid Top.

Grounded Boundaries

- 1 In the **Geometry** toolbar, click  **Selections** and choose **Explicit Selection**.
- 2 In the **Settings** window for **Explicit Selection**, type Grounded Boundaries in the **Label** text field.
- 3 Locate the **Entities to Select** section. From the **Geometric entity level** list, choose **Boundary**.
- 4 Scroll down in the upper section of the **Selection List** window, Ctrl-click to select boundaries 556 and 601.
- 5 Click **Add** at top of the **Selection List** window to add the boundaries to the selection.

Heat Flux Boundaries

- 1 In the **Geometry** toolbar, click  **Selections** and choose **Difference Selection**.
- 2 In the **Settings** window for **Difference Selection**, type Heat Flux Boundaries in the **Label** text field.
- 3 Locate the **Geometric Entity Level** section. From the **Level** list, choose **Boundary**.
- 4 Locate the **Input Entities** section. Click the **+ Add** button for **Selections to add**.
- 5 In the **Add** dialog, select **Adjacent Selection 1** in the **Selections to add** list.
- 6 Click **OK**.
- 7 In the **Settings** window for **Difference Selection**, locate the **Input Entities** section.
- 8 Click the **+ Add** button for **Selections to subtract**.
- 9 In the **Add** dialog, in the **Selections to subtract** list, choose **Electrolyte Boundary** and **Grounded Boundaries**.
- 10 Click **OK**.

