



Model created in COMSOL Multiphysics 6.4

# Neutralization of a Proton Beam Through a Charge Exchange Cell

## Introduction

---

Collisions of neutral particle beams with target materials at various projectile energies are important in a number of applications ranging from plasma physics to material processing.

Beams of high-velocity neutral particles can be obtained using charge exchange cells. A charge exchange cell is a region of high-density gas placed on the path of an ion beam. The region of high gas density creates a medium in which fast ions can be neutralized to generate a beam of neutral particles at the exit of the cell.

Figure 1 shows the concept behind a charge exchange cell. Protons are accelerated toward a cell filled with neutral argon. When they pass through the charge exchange cell, the protons can capture electrons from the argon atoms and exit the cell as fast neutral hydrogen atoms. Since the probability of electron capture is not very high, charged particles are still present in the beam as it exits the cell. In order to get a pure neutral beam at the end of the process, charged plates can be used to deflect the charged particles before the beam reaches its target.

This model uses the Molecular Flow Module to compute the pressure in the charge exchange cell. The Electrostatics interface is used to compute the electric field that deflects the charged particles. The Charged Particle Tracing interface is used to compute the trajectories and to simulate collisions between the particles and ambient neutral atoms.

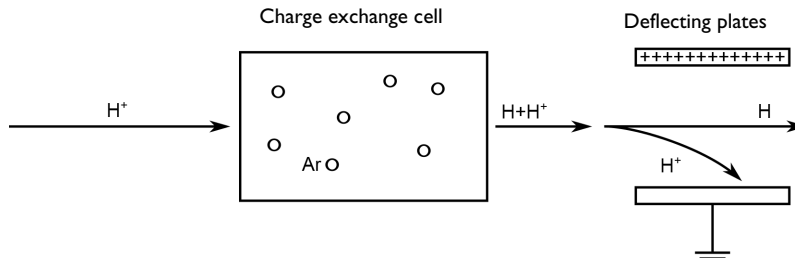

Figure 1: Schematic of a simplified charge exchange cell neutralization process.

## Model Definition

---

The geometry used in the model is shown in Figure 2. The gas cell consists of a tube 40 mm in diameter and 100 mm long. The tube has end caps with 2 mm diameter apertures along the cylinder axis. The argon gas is introduced into the gas cell through a shower head ring located in the center of the cell. The microchannels of the shower head are used to control the neutral gas density in the cell and create a high-pressure region within the main vacuum system of the instrument. To model the gas inflow the Outgassing

Wall boundary condition is used. The gas cell is mounted in a vacuum “T”, which is pumped by a turbomolecular pump (pumping speed of 63 L/s).

The deflecting plates are modeled as two blocks. An electric potential of 200 V is applied on the upper plate while the lower plate is grounded.

As a first approximation, the charge exchange collisions are assumed to have a negligible effect on the direction of particle motion. The energies involved in the collisions are taken from Ref. 1 and are presented in the following reactions.

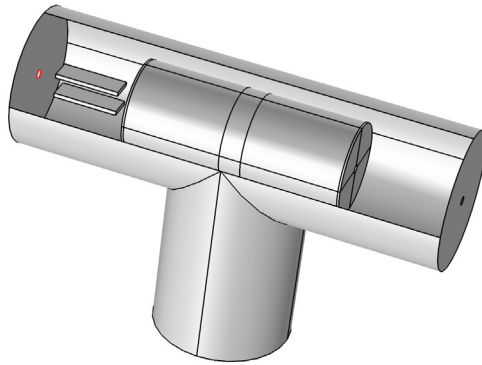
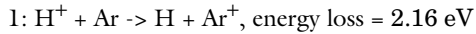

*Figure 2: Schematic of the model geometry.*

## *Results and Discussion*

---

The electric potential distribution in the region surrounding the two plates is plotted in Figure 3. A surface plot of the pressure in the apparatus is shown in Figure 4. The corresponding number density is computed along the symmetry axis of the cylindrical cell and is plotted in Figure 5.

The particle trajectories are plotted in Figure 6. The color expression in this plot indicates the charge number of the atoms, which decreases from 1 (red) to 0 (blue) for particles that undergo charge exchange reactions in the cell. By comparing the number of particles on the plate to the total number of particles in the model, the neutralization efficiency is estimated to be 13.8%. Because the implementation of the charge exchange reactions is

stochastic in nature, this value may change slightly when the model is re-run, depending on the seeding of random numbers.

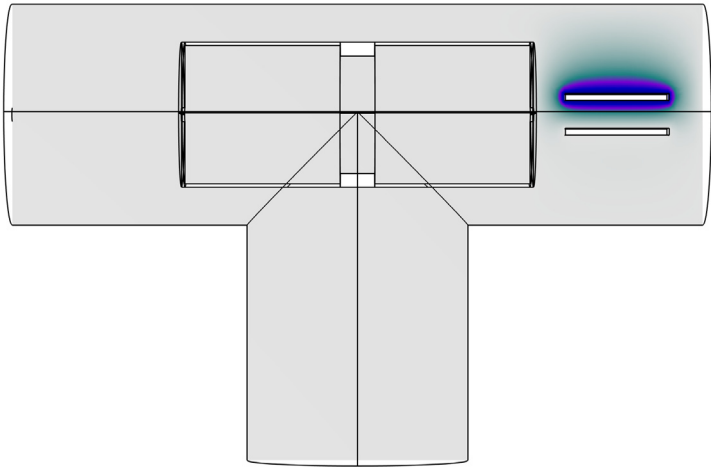

Figure 3: Electric potential in the vacuum housing.

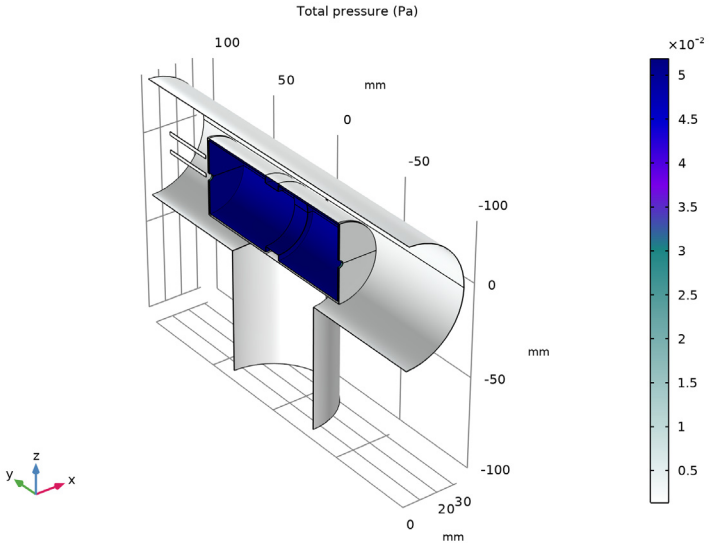
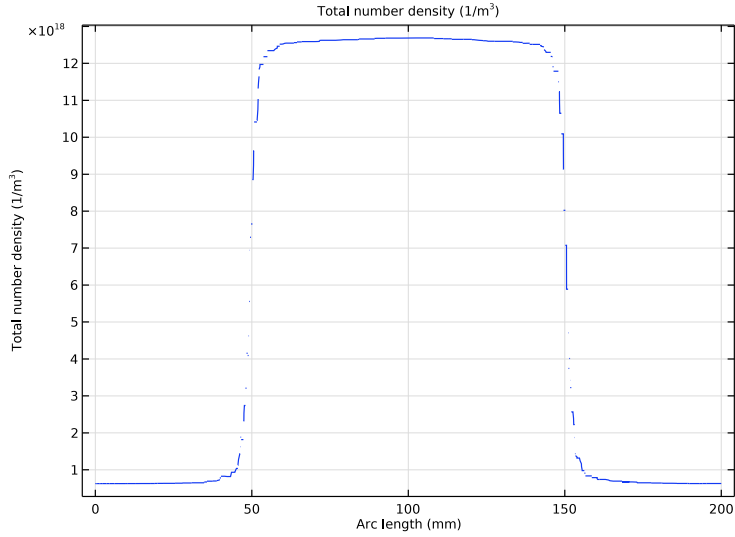
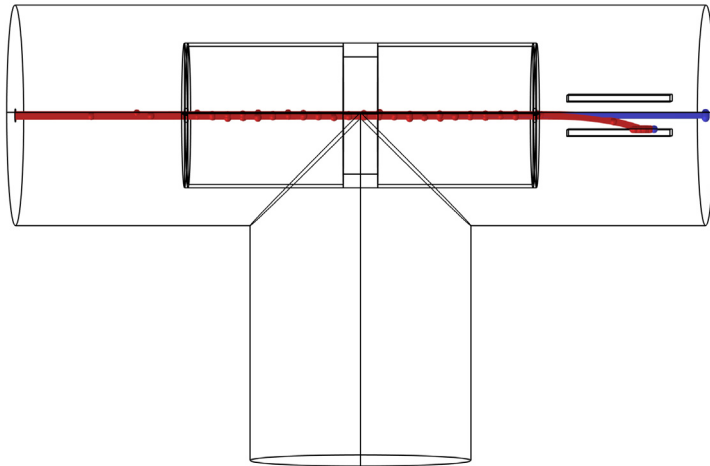

Figure 4: Pressure in the apparatus.



*Figure 5: Axial number density through the gas cell and vacuum housing for argon for a constant mass flow rate of 0.05 sccm into the gas cell.*



*Figure 6: Particle trajectories. Ions are shown in red while neutrals are displayed in blue.*

## Reference

---

I. A. V. Phelps, “Collisions of H<sup>+</sup>, H<sub>2</sub><sup>+</sup>, H<sub>3</sub><sup>+</sup>, ArH<sup>+</sup>, H<sup>-</sup>, H, and H<sub>2</sub> with Ar and of Ar<sup>+</sup> and ArH<sup>+</sup> with H<sub>2</sub> for Energies from 0.1 eV to 10 keV,” *J. Phys. Chem. Ref. Data*, vol. 21, No. 4, pp. 883–897, 1992.

---

**Application Library path:** Molecular\_Flow\_Module/Industrial\_Applications/  
charge\_exchange\_cell

---

## Modeling Instructions



---

From the **File** menu, choose **New**.

### NEW

In the **New** window, click  **Model Wizard**.

### MODEL WIZARD

- 1 In the **Model Wizard** window, click  **3D**.
- 2 In the **Select Physics** tree, select **Fluid Flow** > **Rarefied Flow** > **Free Molecular Flow (fmf)**.
- 3 Click **Add**.
- 4 In the **Select Physics** tree, select **AC/DC** > **Electric Fields and Currents** > **Electrostatics (es)**.
- 5 Click **Add**.
- 6 In the **Select Physics** tree, select **AC/DC** > **Particle Tracing** > **Charged Particle Tracing (cpt)**.
- 7 Click **Add**.
- 8 Click  **Done**.

### GLOBAL DEFINITIONS

#### Parameters I



Load the model parameters from a file.

- 1 In the **Model Builder** window, under **Global Definitions** click **Parameters I**.
- 2 In the **Settings** window for **Parameters**, locate the **Parameters** section.
- 3 Click  **Load from File**.
- 4 Browse to the model's Application Libraries folder and double-click the file `charge_exchange_cell_parameters.txt`.

## DEFINITIONS

Enter raw data from [Ref. 1](#) for the cross sections as a function of the primary particle energy.

$Ar+H+=>H+Ar+$



- 1 In the **Definitions** toolbar, click  **Interpolation**.
- 2 In the **Settings** window for **Interpolation**, type  $Ar+H+=>H+Ar+$  in the **Label** text field.
- 3 Locate the **Definition** section. From the **Data source** list, choose **File**.
- 4 Click  **Browse**.
- 5 Browse to the model's Application Libraries folder and double-click the file `charge_exchange_cell_Qex1.txt`.
- 6 Click  **Import**.
- 7 In the **Function name** text field, type `Qex1`.
- 8 Locate the **Units** section. In the **Argument** table, enter the following settings:

Argument	Unit
t	eV

- 9 In the **Function** table, enter the following settings:

Function	Unit
Qex1	m <sup>2</sup>

$H+Ar=>Ar+H+$



- 1 In the **Definitions** toolbar, click  **Interpolation**.
- 2 In the **Settings** window for **Interpolation**, type  $H+Ar=>Ar+H+$  in the **Label** text field.
- 3 Locate the **Definition** section. From the **Data source** list, choose **File**.
- 4 Click  **Browse**.
- 5 Browse to the model's Application Libraries folder and double-click the file `charge_exchange_cell_Qex2.txt`.
- 6 Click  **Import**.
- 7 In the **Function name** text field, type `Qex2`.
- 8 Locate the **Units** section. In the **Argument** table, enter the following settings:

Argument	Unit
t	eV

9 In the **Function** table, enter the following settings:

Function	Unit
Qex2	m <sup>2</sup>

$H+Ar=>H+Ar+$

- 1 In the **Definitions** toolbar, click  **Interpolation**.
- 2 In the **Settings** window for **Interpolation**, type  $H+Ar=>H+Ar+$  in the **Label** text field.
- 3 Locate the **Definition** section. From the **Data source** list, choose **File**.
- 4 Click  **Browse**.
- 5 Browse to the model's Application Libraries folder and double-click the file `charge_exchange_cell_Qex3.txt`.
- 6 Click  **Import**.
- 7 In the **Function name** text field, type `Qex3`.
- 8 Locate the **Units** section. In the **Argument** table, enter the following settings:



Argument	Unit
t	eV

9 In the **Function** table, enter the following settings:

Function	Unit
Qex3	m <sup>2</sup>

## GEOMETRY I

Insert the prepared geometry sequence from file. You can read the instructions for creating the geometry in the appendix.

- 1 In the **Geometry** toolbar, click **Insert Sequence** and choose **Insert Sequence**.
- 2 Browse to the model's Application Libraries folder and double-click the file `charge_exchange_cell_geom_sequence.mph`.
- 3 In the **Geometry** toolbar, click  **Build All**.
- 4 Click the  **Wireframe Rendering** button in the **Graphics** toolbar in order to see inside the geometry more easily.

## FREE MOLECULAR FLOW (FMF)

Set up the molecular flow simulation. Begin by entering the gas molar mass.

### *Molecular Flow 1*

- 1 In the **Model Builder** window, under **Component 1 (comp1) > Free Molecular Flow (fmf)** click **Molecular Flow 1**.
- 2 In the **Settings** window for **Molecular Flow**, locate the **Molecular Weight of Species** section.
- 3 In the  $M_{n,G}$  text field, type `M_gas`.

### *Wall 2*

- 1 In the **Physics** toolbar, click  **Boundaries** and choose **Wall**.
- 2 In the **Settings** window for **Wall**, locate the **Wall Type** section.
- 3 From the **Wall type** list, choose **Outgassing wall**.
- 4 Locate the **Flux** section. From the **Outgoing flux** list, choose **Number of SCCM units**.
- 5 In the  $Q_{\text{sccm},G}$  text field, type `0.05`.
- 6 From the **Standard flow rate defined by** list, choose **Standard pressure and temperature**.
- 7 Select Boundaries 35, 36, 69, and 71 only.

### *Vacuum Pump 1*

Add the turbomolecular pump inlet.

- 1 In the **Physics** toolbar, click  **Boundaries** and choose **Vacuum Pump**.
- 2 Select Boundary 6 only.
- 3 In the **Settings** window for **Vacuum Pump**, locate the **Vacuum Pump** section.
- 4 From the **Specify pump flux** list, choose **Pump speed**.
- 5 In the  $S_G$  text field, type `63[1/s]`.

In order to have a fast access to the number density in the apparatus, add a **Number Density Reconstruction** node.

### *Number Density Reconstruction 1*

- 1 In the **Physics** toolbar, click  **Domains** and choose **Number Density Reconstruction**.
- 2 Select Domain 1 only.

## **ELECTROSTATICS (ES)**

Now set up the electric field that will deflect the ions.

In the **Model Builder** window, under **Component 1 (comp1)** click **Electrostatics (es)**.

### *Electric Potential 1*

- 1 In the **Physics** toolbar, click  **Boundaries** and choose **Electric Potential**.
- 2 In the **Settings** window for **Electric Potential**, locate the **Electric Potential** section.

- 3 In the  $V_0$  text field, type 200[V].
- 4 Select Boundaries 41–44, 46, and 90 only.

#### *Ground I*

- 1 In the **Physics** toolbar, click  **Boundaries** and choose **Ground**.
- 2 Select Boundaries 1–40, 45, and 48–89 only.

Alternatively, you could select all boundaries and then deselect only boundaries 41, 42, 43, 44, 46, 47, and 90, which are the faces of the upper block. A third option is to drag the **Electric Potential I** node below this node in the Model Builder, since these boundary conditions override each other.

#### **CHARGED PARTICLE TRACING (CPT)**

- 1 In the **Model Builder** window, under **Component I (comp1)** click **Charged Particle Tracing (cpt)**.
- 2 In the **Settings** window for **Charged Particle Tracing**, locate the **Particle Release and Propagation** section.
- 3 In the **Maximum number of secondary particles** text field, type 500.

#### *H+*

- 1 In the **Model Builder** window, under **Component I (comp1)** > **Charged Particle Tracing (cpt)** click **Particle Properties I**.
- 2 In the **Settings** window for **Particle Properties**, type H+ in the **Label** text field.
- 3 Locate the **Particle Mass** section. In the  $m_p$  text field, type M\_p/N\_A\_const.
- 4 Locate the **Charge Number** section. In the  $Z$  text field, type 1.

#### *H*

- 1 In the **Physics** toolbar, click  **Global** and choose **Particle Properties**.
- 2 In the **Settings** window for **Particle Properties**, locate the **Particle Mass** section.
- 3 In the  $m_p$  text field, type M\_p/N\_A\_const.
- 4 Locate the **Charge Number** section. In the  $Z$  text field, type 0.
- 5 In the **Label** text field, type H.

#### *Ar+*

- 1 In the **Physics** toolbar, click  **Global** and choose **Particle Properties**.
- 2 In the **Settings** window for **Particle Properties**, type Ar+ in the **Label** text field.
- 3 Locate the **Particle Mass** section. In the  $m_p$  text field, type M\_gas/N\_A\_const.
- 4 Locate the **Charge Number** section. In the  $Z$  text field, type 1.

### Particle Beam 1

- 1 In the **Physics** toolbar, click  **Boundaries** and choose **Particle Beam**.
- 2 Select Boundary 47 only.
- 3 In the **Settings** window for **Particle Beam**, locate the **Initial Position** section.
- 4 In the  $N$  text field, type NO.
- 5 Locate the **Initial Transverse Velocity** section. In the  $\epsilon_{\text{rms}}$  text field, type 0.1 [um].
- 6 Locate the **Initial Longitudinal Velocity** section. In the  $E$  text field, type 1 [keV].

### Electric Force 1

- 1 In the **Physics** toolbar, click  **Domains** and choose **Electric Force**.
- 2 Select Domain 1 only.
- 3 In the **Settings** window for **Electric Force**, locate the **Electric Force** section.
- 4 From the  $\mathbf{E}$  list, choose **Electric field (es/fsp1)**.

### Ar+H+=>H+Ar+

- 1 In the **Physics** toolbar, click  **Domains** and choose **Collisions**.
- 2 In the **Settings** window for **Collisions**, type Ar+H+=>H+Ar+ in the **Label** text field.
- 3 Select Domain 1 only.
- 4 Locate the **Fluid Properties** section. In the  $N_d$  text field, type fmf.n\_g.
- 5 Locate the **Affected Particles** section. From the **Particles to affect** list, choose **Single species**.

### Nonresonant Charge Exchange 1

- 1 In the **Physics** toolbar, click  **Attributes** and choose **Nonresonant Charge Exchange**.
- 2 In the **Settings** window for **Nonresonant Charge Exchange**, locate the **Collision Frequency** section.
- 3 In the  $\sigma$  text field, type Qex1 (cpt.Ep).
- 4 In the  $\Delta E$  text field, type E1.
- 5 From the **Species to release** list, choose **Ion and neutral particle**.
- 6 Click to expand the **Ion Properties** section. From the **Ion properties** list, choose **Ar+**.
- 7 Click to expand the **Neutral Properties** section. From the **Neutral properties** list, choose **H**.
- 8 Locate the **Collision Statistics** section. Select the **Count collisions** checkbox.

### H+Ar=>Ar+H+

- 1 In the **Model Builder** window, right-click **Ar+H+=>H+Ar+** and choose **Duplicate**.

- 2 In the **Settings** window for **Collisions**, type  $H+Ar \Rightarrow Ar+H+$  in the **Label** text field.
- 3 Locate the **Affected Particles** section. From the **Affected particle properties** list, choose **H**.

#### *Nonresonant Charge Exchange I*

- 1 In the **Model Builder** window, expand the  **$H+Ar \Rightarrow Ar+H+$**  node, then click **Nonresonant Charge Exchange I**.
- 2 In the **Settings** window for **Nonresonant Charge Exchange**, locate the **Collision Frequency** section.
- 3 In the  $\sigma$  text field, type  $Qex2(cpt.Ep)$ .
- 4 In the  $\Delta E$  text field, type  $E2$ .
- 5 From the **Species to release** list, choose **Ion**.
- 6 Locate the **Ion Properties** section. From the **ion properties** list, choose **H+**.

#### *$H+Ar \Rightarrow H+Ar+$*

- 1 In the **Model Builder** window, right-click  **$H+Ar \Rightarrow Ar+H+$**  and choose **Duplicate**.
- 2 In the **Settings** window for **Collisions**, type  $H+Ar \Rightarrow H+Ar+$  in the **Label** text field.

#### *Nonresonant Charge Exchange I*

- 1 In the **Model Builder** window, expand the  **$H+Ar \Rightarrow H+Ar+$**  node, then click **Nonresonant Charge Exchange I**.
- 2 In the **Settings** window for **Nonresonant Charge Exchange**, locate the **Collision Frequency** section.
- 3 In the  $\sigma$  text field, type  $Qex3(cpt.Ep)$ .
- 4 In the  $\Delta E$  text field, type  $E3$ .
- 5 Locate the **Ion Properties** section. From the **ion properties** list, choose **Ar+**.

For postprocessing purposes, create variables for collision statistics.

## **DEFINITIONS**

#### *Variables I*

- 1 In the **Model Builder** window, under **Component I (comp1)** right-click **Definitions** and choose **Variables**.
- 2 In the **Settings** window for **Variables**, locate the **Variables** section.

3 In the table, enter the following settings:

Name	Expression	Unit	Description
Nc1	cpt.sum(cpt.col1.ncex1.Nc)		Number of collisions, type 1
Nc2	cpt.sum(cpt.col2.ncex1.Nc)		Number of collisions, type 2
Nc3	cpt.sum(cpt.col3.ncex1.Nc)		Number of collisions, type 3
Nctot	Nc1+Nc2+Nc3		Total number of collisions

For postprocessing purposes, create a box selection.

*Box 1*

- 1 In the **Definitions** toolbar, click  **Box**.
- 2 In the **Settings** window for **Box**, locate the **Box Limits** section.
- 3 In the **x minimum** text field, type 0.
- 4 Locate the **Geometric Entity Level** section. From the **Level** list, choose **Boundary**.
- 5 Locate the **Output Entities** section. From the **Include entity if** list, choose **All vertices inside box**.

**MESH 1**

In the **Model Builder** window, under **Component 1 (comp1)** right-click **Mesh 1** and choose **Edit Physics-Induced Sequence**.

*Size 3*

- 1 In the **Model Builder** window, under **Component 1 (comp1)** > **Mesh 1** right-click **Size 3** and choose **Disable**.
- 2 In the **Settings** window for **Size**, click  **Build All**.

**ROOT**

Add a stationary study to compute the gas number density and electric field in the vacuum housing and charge exchange cell.



**ADD STUDY**

- 1 In the **Home** toolbar, click  **Add Study** to open the **Add Study** window.
- 2 Go to the **Add Study** window.
- 3 Find the **Physics interfaces in study** subsection. In the table, clear the **Solve** checkbox for **Charged Particle Tracing (cpt)**.

- 4 Find the **Studies** subsection. In the **Select Study** tree, select **General Studies > Stationary**.
- 5 Click the **Add Study** button in the window toolbar.
- 6 In the **Home** toolbar, click  **Add Study** to close the **Add Study** window.

## STUDY 1

### *Solution 1 (sol1)*

- 1 In the **Study** toolbar, click  **Show Default Solver**.
- 2 In the **Model Builder** window, expand the **Solution 1 (sol1)** node.
- 3 In the **Model Builder** window, expand the **Study 1 > Solver Configurations > Solution 1 (sol1) > Stationary Solver 1 > Iterative 2** node, then click **Multigrid 1**.
- 4 In the **Settings** window for **Multigrid**, locate the **General** section.
- 5 In the **Mesh coarsening factor** text field, type 1.
- 6 In the **Model Builder** window, click **Study 1**.
- 7 In the **Settings** window for **Study**, locate the **Study Settings** section.
- 8 Clear the **Generate default plots** checkbox.
- 9 In the **Study** toolbar, click  **Compute**.

Create a new dataset using the **Box 1** selection that was defined earlier.

## RESULTS

In the **Model Builder** window, expand the **Results** node.

### *Study 1/Solution 1 Box Selection*

- 1 In the **Model Builder** window, expand the **Results > Datasets** node.
- 2 Right-click **Results > Datasets > Study 1/Solution 1 (sol1)** and choose **Duplicate**.
- 3 In the **Settings** window for **Solution**, type **Study 1/Solution 1 Box Selection** in the **Label** text field.

### *Selection*

- 1 In the **Results** toolbar, click  **Attributes** and choose **Selection**.
- 2 In the **Settings** window for **Selection**, locate the **Geometric Entity Selection** section.
- 3 From the **Geometric entity level** list, choose **Boundary**.
- 4 From the **Selection** list, choose **Box 1**.

Create a **Cut Line** dataset along the beam line center.

### *Cut Line 3D 1*



- 1 In the **Results** toolbar, click  **Cut Line 3D**.
- 2 In the **Settings** window for **Cut Line 3D**, locate the **Line Data** section.
- 3 In row **Point 1**, set **y** to -100.
- 4 In row **Point 2**, set **y** to 100 and **x** to 0.

Plot the electric potential created by the deflecting plates.

### *Electric Potential*

- 1 In the **Results** toolbar, click  **3D Plot Group**.
- 2 In the **Settings** window for **3D Plot Group**, type Electric Potential in the **Label** text field.

### *Slice 1*

- 1 Right-click **Electric Potential** and choose **Slice**.
- 2 In the **Settings** window for **Slice**, locate the **Plane Data** section.
- 3 In the **Planes** text field, type 1.
- 4 Click the  **Go to YZ View** button in the **Graphics** toolbar.
- 5 Locate the **Expression** section. In the **Expression** text field, type V.
- 6 Locate the **Coloring and Style** section. From the **Color table** list, choose **AuroraAustralis**.
- 7 In the **Electric Potential** toolbar, click  **Plot**.
- 8 Click the  **Zoom Extents** button in the **Graphics** toolbar.

Plot the pressure in the apparatus.

### *Pressure*

- 1 In the **Results** toolbar, click  **3D Plot Group**.
- 2 In the **Settings** window for **3D Plot Group**, type Pressure in the **Label** text field.
- 3 Locate the **Data** section. From the **Dataset** list, choose **Study 1 / Solution 1 Box Selection (sol1)**.

### *Surface 1*

- 1 Right-click **Pressure** and choose **Surface**.
- 2 In the **Settings** window for **Surface**, locate the **Expression** section.
- 3 In the **Expression** text field, type  $f_{mf}.ptot$ .
- 4 Locate the **Coloring and Style** section. From the **Color table** list, choose **AuroraAustralis**.
- 5 In the **Pressure** toolbar, click  **Plot**.

6 Click the  **Go to Default View** button in the **Graphics** toolbar.

Plot the neutral gas number density along the center of the beam line.

#### *Gas Number Density*



- 1 In the **Results** toolbar, click  **ID Plot Group**.
- 2 In the **Settings** window for **ID Plot Group**, type Gas Number Density in the **Label** text field.
- 3 Locate the **Data** section. From the **Dataset** list, choose **Cut Line 3D I**.

#### *Line Graph 1*

- 1 Right-click **Gas Number Density** and choose **Line Graph**.
- 2 In the **Settings** window for **Line Graph**, locate the **y-Axis Data** section.
- 3 In the **Expression** text field, type `fmf.ntot`.
- 4 In the **Gas Number Density** toolbar, click  **Plot**.

Add a transient study to simulate the beam neutralization.

### **ADD STUDY**

- 1 In the **Home** toolbar, click  **Add Study** to open the **Add Study** window.
- 2 Go to the **Add Study** window.
- 3 Find the **Physics interfaces in study** subsection. In the table, clear the **Solve** checkboxes for **Free Molecular Flow (fmf)** and **Electrostatics (es)**.
- 4 Find the **Studies** subsection. In the **Select Study** tree, select **General Studies > Time Dependent**.
- 5 Click the **Add Study** button in the window toolbar.
- 6 In the **Home** toolbar, click  **Add Study** to close the **Add Study** window.

### **STUDY 2**

#### *Step 1: Time Dependent*

Use the values of variables computed from the previous study, that is, the electric field and the gas number density.

- 1 In the **Settings** window for **Time Dependent**, locate the **Study Settings** section.
- 2 From the **Time unit** list, choose **µs**.
- 3 Click  **Range**.
- 4 In the **Range** dialog, type 0.01 in the **Step** text field.

- 5 In the **Stop** text field, type 0.5.
- 6 Click **Replace**.
- 7 In the **Settings** window for **Time Dependent**, click to expand the **Values of Dependent Variables** section.
- 8 Find the **Values of variables not solved for** subsection. From the **Settings** list, choose **User controlled**.
- 9 From the **Method** list, choose **Solution**.
- 10 From the **Study** list, choose **Study 1, Stationary**.

Set the maximum time step taken by the solver to be about an order of magnitude less than the inverse of the collision frequency. This is an important detail for the Monte Carlo collision model because collisions are only applied at discrete time steps taken by the solver.

#### *Solution 2 (sol2)*

- 1 In the **Study** toolbar, click  **Show Default Solver**.
- 2 In the **Model Builder** window, expand the **Solution 2 (sol2)** node, then click **Time-Dependent Solver 1**.
- 3 In the **Settings** window for **Time-Dependent Solver**, click to expand the **Time Stepping** section.
- 4 From the **Maximum step constraint** list, choose **Constant**.
- 5 In the **Maximum step** text field, type 10[ns].

#### *Step 1: Time Dependent*

In the **Study** toolbar, click  **Compute**.

## **RESULTS**



#### *Particle Trajectories (cpt)*

A default **Particle Trajectories** plot is created. Display the particle charge in the **Color Expression 1** subnode.

#### *Particle Trajectories 1*

- 1 In the **Model Builder** window, expand the **Particle Trajectories (cpt)** node, then click **Particle Trajectories 1**.
- 2 In the **Settings** window for **Particle Trajectories**, locate the **Coloring and Style** section.
- 3 Find the **Line style** subsection. From the **Type** list, choose **Line**.

### Color Expression 1

- 1 In the **Model Builder** window, expand the **Particle Trajectories 1** node, then click **Color Expression 1**.
- 2 In the **Settings** window for **Color Expression**, locate the **Expression** section.
- 3 In the **Expression** text field, type `cpt.Z`.
- 4 Locate the **Coloring and Style** section. From the **Color table** list, choose **RainbowLight**.
- 5 Click the  **Go to YZ View** button in the **Graphics** toolbar.
- 6 In the **Particle Trajectories (cpt)** toolbar, click  **Plot**.
- 7 Click the  **Zoom Extents** button in the **Graphics** toolbar.

Compute the neutralization efficiency. Duplicate the **Particle 1** dataset and create a boundary selection for the wall at the opposite of the aperture wall.

### Particle 2

In the **Model Builder** window, under **Results > Datasets** right-click **Particle 1** and choose **Duplicate**.

### Selection

- 1 In the **Results** toolbar, click  **Attributes** and choose **Selection**.
- 2 In the **Settings** window for **Selection**, locate the **Geometric Entity Selection** section.
- 3 From the **Geometric entity level** list, choose **Boundary**.
- 4 Select Boundary 8 only.

### Efficiency

- 1 In the **Results** toolbar, click  **Global Evaluation**.
- 2 In the **Settings** window for **Global Evaluation**, type Efficiency in the **Label** text field.
- 3 Locate the **Data** section. From the **Dataset** list, choose **Particle 2**.
- 4 From the **Time selection** list, choose **Last**.
- 5 Locate the **Expressions** section. In the table, enter the following settings:

Expression	Unit	Description
<code>cpt.Nse1/N0*100</code>	1	

### $Nc1/Nctot$

- 1 Right-click **Efficiency** and choose **Duplicate**.
- 2 In the **Settings** window for **Global Evaluation**, type  $Nc1/Nctot$  in the **Label** text field.

3 Locate the **Expressions** section. In the table, enter the following settings:

Expression	Unit	Description
Nc1/Nctot*100	1	

*Nc2/Nctot*

- 1 Right-click **Nc1/Nctot** and choose **Duplicate**.
- 2 In the **Settings** window for **Global Evaluation**, type Nc2/Nctot in the **Label** text field.
- 3 Locate the **Expressions** section. In the table, enter the following settings:

Expression	Unit	Description
Nc2/Nctot*100	1	

*Nc3/Nctot*

- 1 Right-click **Nc2/Nctot** and choose **Duplicate**.
- 2 In the **Settings** window for **Global Evaluation**, type Nc3/Nctot in the **Label** text field.
- 3 Locate the **Expressions** section. In the table, enter the following settings:

Expression	Unit	Description
Nc3/Nctot*100	1	

4 In the **Results** toolbar, click  **Evaluate** and choose **Clear and Evaluate All**.

#### TABLE 4

Go to the **Table 4** window. Results are displayed in tables 1 to 4 by clicking on the associated node under the **Derived Values** node.

### *Appendix — Geometry Instructions*

#### GEOMETRY I

- 1 In the **Model Builder** window, under **Component 1 (comp1)** click **Geometry 1**.
- 2 In the **Settings** window for **Geometry**, locate the **Units** section.
- 3 From the **Length unit** list, choose **mm**.

The gas cell geometry is created by filling in a cross section and then taking the solid of revolution.

*Work Plane 1 (wp1)*

- 1 In the **Geometry** toolbar, click  **Work Plane**.

- 2 In the **Settings** window for **Work Plane**, locate the **Unite Objects** section.
- 3 Clear the **Unite objects** checkbox.
- 4 Click  **Go to Plane Geometry**.

*Work Plane 1 (wp1) > Rectangle 1 (r1)*

- 1 In the **Work Plane** toolbar, click  **Rectangle**.
- 2 In the **Settings** window for **Rectangle**, locate the **Size and Shape** section.
- 3 In the **Width** text field, type 4.
- 4 In the **Height** text field, type 10.
- 5 Locate the **Position** section. In the **xw** text field, type 17.
- 6 In the **yw** text field, type -5.



*Work Plane 1 (wp1) > Rectangle 2 (r2)*

- 1 In the **Work Plane** toolbar, click  **Rectangle**.
- 2 In the **Settings** window for **Rectangle**, locate the **Size and Shape** section.
- 3 In the **Height** text field, type 100.
- 4 Locate the **Position** section. In the **xw** text field, type 20.
- 5 In the **yw** text field, type -50.

*Work Plane 1 (wp1) > Rectangle 3 (r3)*

- 1 In the **Work Plane** toolbar, click  **Rectangle**.
- 2 In the **Settings** window for **Rectangle**, locate the **Size and Shape** section.
- 3 In the **Width** text field, type 19.
- 4 Locate the **Position** section. In the **xw** text field, type 2.
- 5 In the **yw** text field, type 50.

*Work Plane 1 (wp1) > Rectangle 4 (r4)*

- 1 In the **Work Plane** toolbar, click  **Rectangle**.
- 2 In the **Settings** window for **Rectangle**, locate the **Size and Shape** section.
- 3 In the **Width** text field, type 19.
- 4 Locate the **Position** section. In the **xw** text field, type 2.
- 5 In the **yw** text field, type -51.
- 6 Click the  **Zoom Extents** button in the **Graphics** toolbar.

*Work Plane 1 (wp1) > Union 1 (uni1)*

- 1 In the **Work Plane** toolbar, click  **Booleans and Partitions** and choose **Union**.

- 2 Click in the **Graphics** window and then press Ctrl+A to select all objects.
- 3 In the **Settings** window for **Union**, click  **Build Selected**.

*Revolve 1 (rev1)*



- 1 In the **Model Builder** window, right-click **Geometry 1** and choose **Revolve**.
- 2 In the **Settings** window for **Revolve**, click  **Build Selected**.

Create the vacuum housing that surrounds the gas cell.



*Cylinder 1 (cyl1)*

- 1 In the **Geometry** toolbar, click  **Cylinder**.
- 2 In the **Settings** window for **Cylinder**, locate the **Size and Shape** section.
- 3 In the **Radius** text field, type 32.
- 4 In the **Height** text field, type 200.
- 5 Locate the **Position** section. In the **y** text field, type -100.
- 6 Locate the **Axis** section. From the **Axis type** list, choose **y-axis**.

*Cylinder 2 (cyl2)*

- 1 In the **Geometry** toolbar, click  **Cylinder**.
- 2 In the **Settings** window for **Cylinder**, locate the **Size and Shape** section.
- 3 In the **Radius** text field, type 32.
- 4 In the **Height** text field, type 100.
- 5 Locate the **Position** section. In the **z** text field, type -100.
- 6 Click  **Build Selected**.
- 7 Click the  **Zoom Extents** button in the **Graphics** toolbar.

*Union 1 (uni1)*

- 1 In the **Geometry** toolbar, click  **Booleans and Partitions** and choose **Union**.
- 2 Select the objects **cyl1** and **cyl2** only.
- 3 In the **Settings** window for **Union**, locate the **Union** section.
- 4 Clear the **Keep interior boundaries** checkbox.
- 5 Click  **Build Selected**.



Create two blocks to represent the deflecting plates.

*Block 1 (blk1)*

- 1 In the **Geometry** toolbar, click  **Block**.
- 2 In the **Settings** window for **Block**, locate the **Size and Shape** section.



- 3 In the **Width** text field, type 10.
- 4 In the **Depth** text field, type 30.
- 5 In the **Height** text field, type 2.
- 6 Locate the **Position** section. From the **Base** list, choose **Center**.
- 7 In the **y** text field, type 75.
- 8 In the **z** text field, type 5.

*Block 2 (blk2)*

- 1 In the **Geometry** toolbar, click  **Block**.
- 2 In the **Settings** window for **Block**, locate the **Size and Shape** section.
- 3 In the **Width** text field, type 10.
- 4 In the **Depth** text field, type 30.
- 5 In the **Height** text field, type 2.
- 6 Locate the **Position** section. From the **Base** list, choose **Center**.
- 7 In the **y** text field, type 75.
- 8 In the **z** text field, type -5.
- 9 Click  **Build Selected**.

Subtract all solid domains from the geometry. The simulation domain is just the volume within the gas cell and vacuum chamber, where the beam will propagate.

*Difference 1 (dif1)*

- 1 In the **Geometry** toolbar, click  **Booleans and Partitions** and choose **Difference**.
- 2 Select the object **uni1** only.
- 3 In the **Settings** window for **Difference**, locate the **Difference** section.
- 4 Click to select the  **Activate Selection** toggle button for **Objects to subtract**.
- 5 Select the objects **blk1**, **blk2**, and **rev1** only.
- 6 Click  **Build Selected**.

Create an aperture for the ion beam to enter on one side of the chamber.

*Work Plane 2 (wp2)*

- 1 In the **Geometry** toolbar, click  **Work Plane**.
- 2 In the **Settings** window for **Work Plane**, locate the **Plane Definition** section.
- 3 From the **Plane** list, choose **xz-plane**.
- 4 In the **y-coordinate** text field, type -100.

5 Click  **Go to Plane Geometry**.

*Work Plane 2 (wp2) > Circle 1 (c1)*

1 In the **Work Plane** toolbar, click  **Circle**.

2 In the **Settings** window for **Circle**, locate the **Size and Shape** section.

3 In the **Radius** text field, type 2.

4 In the **Work Plane** toolbar, click  **Build All**.

5 Click the  **Zoom Extents** button in the **Graphics** toolbar.

6 Right-click **Geometry I** and choose **Build All**.

7 Click the  **Zoom Extents** button in the **Graphics** toolbar.