

Model created in COMSOL Multiphysics 6.4

Turbulent Modular Mixer – Template File

This model is a template MPH file used by the turbulent cases ($k\text{-}\epsilon$ and $k\text{-}\omega$ turbulence models) of the [Modular Mixer](#) models. The geometry is a combination of a pitched blade impeller and a dished bottom tank. The geometry subsequences to build the impeller and vessel are imported from the Part Libraries.

Application Library path: Mixer_Module/Tutorials/
modular_mixer_turbulent_geom

Modeling Instructions

ADD COMPONENT

In the **Home** toolbar, click  **Add Component** and choose **3D**.



GLOBAL DEFINITIONS

Parameters 1

- 1** In the **Model Builder** window, under **Global Definitions** click **Parameters 1**.
- 2** In the **Settings** window for **Parameters**, locate the **Parameters** section.
- 3** In the table, enter the following settings:

Name	Expression	Value	Description
H	0.5[m]	0.5 m	Vessel height
T	H	0.5 m	Vessel diameter
alpha	45[deg]	0.7854 rad	Pitch angle
N_blades	4	4	Number of blades for pitched blade impeller
B	4	4	Number of baffles
Da	1/2*T	0.25 m	Impeller diameter
blade_width	Da/5	0.05 m	Width of impeller blade
bw	T/12	0.041667 m	Baffle width
C	1/4*H	0.125 m	Clearance
shaft_diameter	1/10*Da	0.025 m	Shaft diameter

PART LIBRARIES

- 1 In the **Geometry** toolbar, click  **Part Libraries**.
- 2 In the **Model Builder** window, under **Component 1 (comp1)** click **Geometry 1**.
- 3 In the **Part Libraries** window, select **Mixer Module > Impellers**,
Surface Blade Representation > Impellers, Axial > pitched_blade_impeller in the tree.
- 4 Click  **Add to Geometry**.

GEOMETRY 1

Pitched Blade Impeller 1 (pi1)

- 1 In the **Model Builder** window, under **Component 1 (comp1) > Geometry 1** click **Pitched Blade Impeller 1 (pi1)**.
- 2 In the **Settings** window for **Part Instance**, locate the **Input Parameters** section.
- 3 In the table, enter the following settings:

Name	Expression	Value	Description
d_hu	$\text{blade_width} * \text{abs}(\cos(\alpha)) * 1.1$	0.038891 m	Diameter of impeller hub
ap_ib	alpha	45 °	Pitch angle of the impeller blade
d_a_ib	$\text{blade_width} * \cos(\alpha) * 0.95$	0.033588 m	Diameter of the attachment section of the impeller blade with the hub
lr_cl_ib	0.3[1]	0.3	Position of the cutting point relative to the total blade length at the lower edge of the impeller
lr_cu_ib	0.3[1]	0.3	Position of the cutting point relative to the total blade length at the upper edge of the impeller

Name	Expression	Value	Description
n_ib	N_blades	4	Number of impeller blades
rf_ib	0[m]	0 m	Fillet radius of impeller blade
w_ib	blade_width	0.05 m	Width of the impeller blade
w_a_ib	0[m]	0 m	Blade attachment width
w_o_ib	blade_width	0.05 m	Outer width of the impeller blade
w_cil_ib	blade_width*0.25	0.0125 m	Width of inner-lower cut
w_ciu_ib	blade_width*0.25	0.0125 m	Width of inner-upper cut
w_col_ib	0[m]	0 m	Width of outer-lower cut
d_im	Da	0.25 m	Impeller diameter
hp_im	-blade_width*sin(alpha)/2	-0.01768 m	Position of the lowest part of the impeller hub or impeller shaft along the z-axis
d_is	shaft_diameter	0.025 m	Diameter of impeller shaft

Name	Expression	Value	Description
pa_cs_im	1	1	Add cross-section planes for flow evaluation above and below the impeller: 1 = add planes, 0 = do not add planes.
d_cs_im	Da*1.2	0.3 m	Diameter of cross-section planes above and below the impeller. The planes are used to compute power draw and flow numbers.

- 4 Click to expand the **Object Selections** section. Click **New Cumulative Selection**.
- 5 In the **New Cumulative Selection** dialog, type Impeller Domains in the **Name** text field.
- 6 Click **OK**.
- 7 In the **Settings** window for **Part Instance**, locate the **Object Selections** section.
- 8 Click **New Cumulative Selection**.
- 9 In the **New Cumulative Selection** dialog, type Control Domain in the **Name** text field.
- 10 Click **OK**.
- 11 In the table, enter the following settings:

Name	Contribute to
Impeller	Impeller Domains
Tank	Control Domain

- 12 In the **Settings** window for **Part Instance**, click to expand the **Boundary Selections** section.
- 13 Click **New Cumulative Selection**.
- 14 In the **New Cumulative Selection** dialog, type Rotating Interior Wall in the **Name** text field.
- 15 Click **OK**.

16 In the **Settings** window for **Part Instance**, locate the **Boundary Selections** section.

17 Click **New Cumulative Selection**.

18 In the **New Cumulative Selection** dialog, type Rotating Wall in the **Name** text field.

19 Click **OK**.

20 In the **Settings** window for **Part Instance**, locate the **Boundary Selections** section.

21 Click **New Cumulative Selection**.

22 In the **New Cumulative Selection** dialog, type View Suppression in the **Name** text field.

23 Click **OK**.

24 In the **Settings** window for **Part Instance**, locate the **Boundary Selections** section.

25 Click **New Cumulative Selection**.

26 In the **New Cumulative Selection** dialog, type Mesh in the **Name** text field.

27 Click **OK**.

28 In the table, enter the following settings:

Name	Contribute to
Impeller blades	Rotating Interior Wall
Impeller hub	Rotating Wall
Control surface upper	Mesh
Control surface lower	Mesh
Control surface side	Mesh
Surfaces to hide	View Suppression

29 In the **Settings** window for **Part Instance**, click to expand the **Edge Selections** section.

30 Click **New Cumulative Selection**.

31 In the **New Cumulative Selection** dialog, type Remove Edges in the **Name** text field.

32 Click **OK**.



33 In the table, enter the following settings:

Name	Contribute to
Edges to remove	Remove Edges

34 In the **Settings** window for **Part Instance**, locate the **Selection Settings** section.

35 Select the **Keep noncontributing selections** checkbox.

PART LIBRARIES

- 1 In the **Geometry** toolbar, click  **Part Libraries**.
- 2 In the **Model Builder** window, click **Geometry 1**.
- 3 In the **Part Libraries** window, select **Mixer Module > Shafts > impeller_shaft** in the tree.
- 4 Click  **Add to Geometry**.

GEOMETRY 1

Impeller Shaft 1 (pi2)

- 1 In the **Model Builder** window, under **Component 1 (comp1) > Geometry 1** click **Impeller Shaft 1 (pi2)**.
- 2 In the **Settings** window for **Part Instance**, locate the **Input Parameters** section.
- 3 In the table, enter the following settings:

Name	Expression	Value	Description
hp_im	$-\text{blade_width} * \sin(\alpha) / 2$	-0.017678 m	Position of the lowest part of the impeller hub or impeller shaft along the z-axis
d_is	shaft_diameter	0.025 m	Impeller shaft diameter
l_is	H-C	0.375 m	Impeller shaft length

- 4 Click to expand the **Object selections** section. In the table, enter the following settings:

Name	Contribute to
Impeller	Impeller Domains

- 5 Click to expand the **Boundary selections** section. In the table, enter the following settings:



Name	Contribute to
Exterior	None
Impeller	Rotating Wall

- 6 Click to expand the **Edge selections** section. In the table, enter the following settings:

Name	Contribute to
Edges to remove	Remove Edges
Impeller	None

- 7 Locate the **Selection Settings** section. Select the **Keep noncontributing selections** checkbox.

PART LIBRARIES

- 1 In the **Geometry** toolbar, click  **Part Libraries**.
- 2 In the **Model Builder** window, click **Geometry 1**.
- 3 In the **Part Libraries** window, select **Mixer Module > Tanks > dished_bottom_tank** in the tree.
- 4 Click  **Add to Geometry**.

GEOMETRY 1

Dished Bottom Tank 1 (pi3)

- 1 In the **Model Builder** window, under **Component 1 (comp1) > Geometry 1** click **Dished Bottom Tank 1 (pi3)**.
- 2 In the **Settings** window for **Part Instance**, locate the **Input Parameters** section.
- 3 In the table, enter the following settings:

Name	Expression	Value	Description
n_ba	B	4	Number of baffles
w_ba	bw	0.041667 m	Baffle width
d_im	Da	0.25 m	Impeller diameter
d_ta	T	0.5 m	Tank diameter
h_ta	H	0.5 m	Tank height
hp_ta	-C	-0.125 m	Height position, cylindrical surface
rm_b_ta	T/10	0.05 m	Minor radius of the tank bottom
bo_rd_ta	T*2	1 m	Bottom offset of rotating domain relative to the tank bottom minor radius
t_ta	0	0 m	Thickness of tank wall
t_ba	0	0 m	Thickness of tank baffles

- 4 Locate the **Boundary Selections** section. Click **New Cumulative Selection**.
- 5 In the **New Cumulative Selection** dialog, type **Interior Wall** in the **Name** text field.
- 6 Click **OK**.
- 7 In the **Settings** window for **Part Instance**, locate the **Boundary Selections** section.

8 Click **New Cumulative Selection**.

9 In the **New Cumulative Selection** dialog, type Symmetry in the **Name** text field.

10 Click **OK**.

11 In the table, enter the following settings:

Name	Contribute to
All	Control Domain

12 Click to expand the **Boundary selections** section. In the table, enter the following settings:

Name	Contribute to
Baffles	Interior Wall
Fluid surface	Symmetry
Surfaces to hide	View suppression

13 In the **Settings** window for **Part Instance**, locate the **Selection Settings** section.

14 Select the **Keep noncontributing selections** checkbox to keep all selections from the part.

Rotating Fluid Domain

1 In the **Geometry** toolbar, click  **Booleans and Partitions** and choose **Difference**.

2 In the **Settings** window for **Difference**, type Rotating Fluid Domain in the **Label** text field.

3 Locate the **Difference** section. From the **Objects to add** list, choose **Control Domain**.

4 From the **Objects to subtract** list, choose **Impeller Domains**.

5 From the **Repair tolerance** list, choose **Relative**.

6 Locate the **Selections of Resulting Entities** section. Select the **Resulting objects selection** checkbox.

7 From the **Show in physics** list, choose **All levels**.

8 Click  **Build Selected**.

Reduce the domain to a quarter of the original size.

Block 1 (blk1)

1 In the **Geometry** toolbar, click  **Block**.

2 In the **Settings** window for **Block**, locate the **Position** section.



3 In the **x** text field, type 0.2.

- 4 In the **y** text field, type -0.2.
- 5 In the **z** text field, type -0.5.
- 6 Locate the **Rotation Angle** section. In the **Rotation** text field, type 45.

Block 2 (blk2)

- 1 Right-click **Block 1 (blk1)** and choose **Duplicate**.
- 2 In the **Settings** window for **Block**, locate the **Position** section.
- 3 In the **x** text field, type -0.2.

Difference 2 (dif2)

- 1 In the **Geometry** toolbar, click  **Booleans and Partitions** and choose **Difference**.
- 2 Select the object **dif1** only.
- 3 In the **Settings** window for **Difference**, locate the **Difference** section.
- 4 Click to select the  **Activate Selection** toggle button for **Objects to subtract**.
- 5 Select the objects **blk2** and **blk1** only.

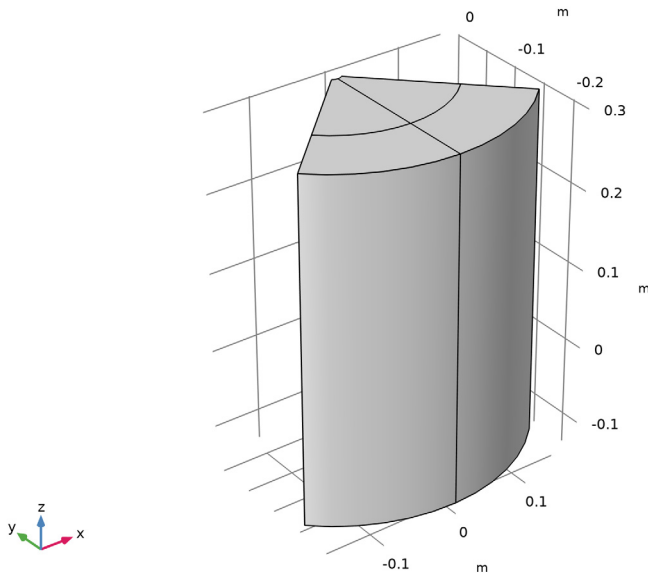

Flat Pressure Point

- 1 In the **Geometry** toolbar, click  **Selections** and choose **Explicit Selection**.
- 2 In the **Settings** window for **Explicit Selection**, type Flat Pressure Point in the **Label** text field.

- 3 Locate the **Entities to Select** section. From the **Geometric entity level** list, choose **Point**.
- 4 On the object **diff2**, select Point 19 only.

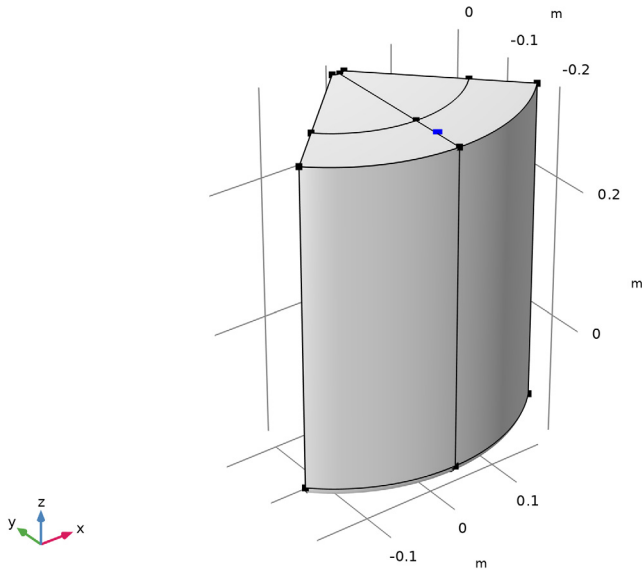

- 5 In the **Model Builder** window, click **Flat Pressure Point (sel1)**.
- 6 Locate the **Resulting Selection** section. Find the **Cumulative selection** subsection. Click **New**.
- 7 In the **New Cumulative Selection** dialog, type Pressure Point Constraint in the **Name** text field.
- 8 Click **OK**.

Form Union (fin)



- 1 In the **Model Builder** window, under **Component 1 (comp1) > Geometry 1** click **Form Union (fin)**.
- 2 In the **Settings** window for **Form Union/Assembly**, locate the **Form Union/Assembly** section.
- 3 From the **Action** list, choose **Form an assembly**.
- 4 Clear the **Create pairs** checkbox.
- 5 From the **Repair tolerance** list, choose **Relative**.

Ignore Edges 1 (igel)



- 1 In the **Geometry** toolbar, click  **Virtual Operations** and choose **Ignore Edges**.

- 2 In the **Settings** window for **Ignore Edges**, locate the **Input** section.
- 3 From the **Edges to ignore** list, choose **Remove Edges**.

Mesh Control Faces 1 (mcf1)

- 1 In the **Geometry** toolbar, click  **Virtual Operations** and choose **Mesh Control Faces**.
- 2 In the **Settings** window for **Mesh Control Faces**, locate the **Input** section.
- 3 Click to select the  **Activate Selection** toggle button for **Faces to include**.
- 4 From the **Faces to include** list, choose **Mesh**.
- 5 In the **Geometry** toolbar, click  **Build All**.

Union Selection: All Walls

- 1 In the **Geometry** toolbar, click  **Selections** and choose **Union Selection**.
- 2 In the **Settings** window for **Union Selection**, type Union Selection: All Walls in the **Label** text field.
- 3 Locate the **Geometric Entity Level** section. From the **Level** list, choose **Boundary**.
- 4 Locate the **Input Entities** section. Click  **Add**.
- 5 In the **Add** dialog, in the **Selections to add** list, choose **Rotating Interior Wall**, **Rotating Wall**, **Interior Wall**, and **Tank walls (Dished Bottom Tank 1)**.
- 6 Click **OK**.

The model geometry is now complete.