



Model created in COMSOL Multiphysics 6.4

Free Surface Mixer Level Set

Introduction

This example of turbulent two-phase flow in a partially baffled mixer shows how to set up a time dependent, turbulent two-phase flow simulation together with a rotating domain. The interface between the two fluids, water and air, is modeled using a level-set approach, and turbulence is modeled using the k - ϵ turbulence model. The mixer geometry used in this model corresponds to the one used by J.-P. Torr  and others (Ref. 1), and the results can be compared with experiments.

Model Definition

The mixer is a glass-lined, under-baffled stirred vessel. Figure 1 shows the model geometry. The mixer includes a three-bladed impeller and two beavertail baffles supported at the top of the vessel. The tank bottom is curved, allowing the three-bladed impeller to be placed close to the bottom. The cylindrical part of the tank has a diameter of 450 mm, and the initial water level is 467 mm. The two contoured baffles hang from the top of the mixer, and their lower part is 256 mm above the bottom of the vessel.

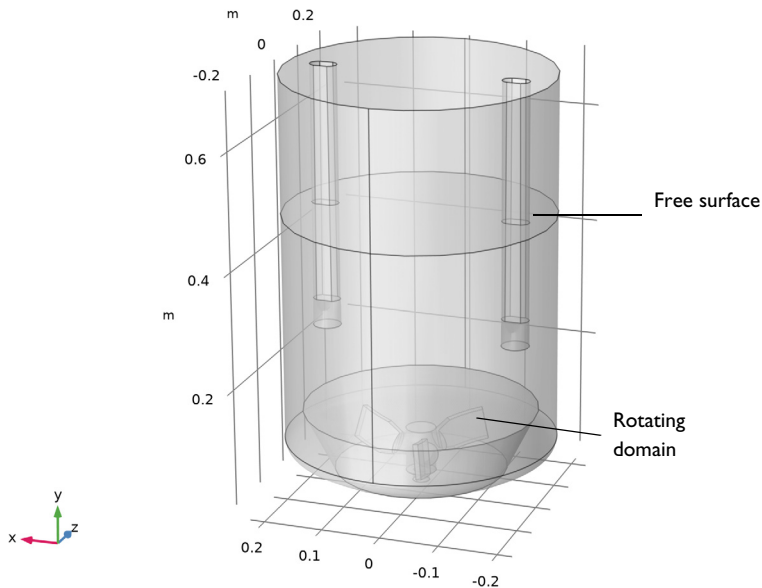

Figure 1: Geometry of the mixer with two rods and a three-bladed impeller.

The model uses a time dependent simulation starting from rest. The rotational velocity of the impeller is gradually increased until it reaches 275 rpm at $t = 5$ s, and the simulation is continued until $t = 5.5$ s. The flow in the mixer is modeled using a Two-Phase Flow, Level Set physics interface, to track the interface between water and air, with a k - ϵ turbulence model.

Results and Discussion

The results, presented in this section, focus on the shape of the unstable free surface. The free surface is plotted at different times in Figure 2 to Figure 8. The surface remains essentially unperturbed until, at around $t = 4.0$ s, it starts forming a “bath-tub vortex.” The vortex is fully developed and reaches the bottom at $t = 4.5$ s. Once the impeller reaches the maximum rotational velocity, at $t = 5$ s, the shape of the free surface agrees with the experimental and numerical results presented in Ref. 1. The vortex is more or less stable for a short while before it breaks at the impeller and air bubbles are entrained into the water bulk. This last stage is not included in this model, but can be observed if the simulation is extended for another second.

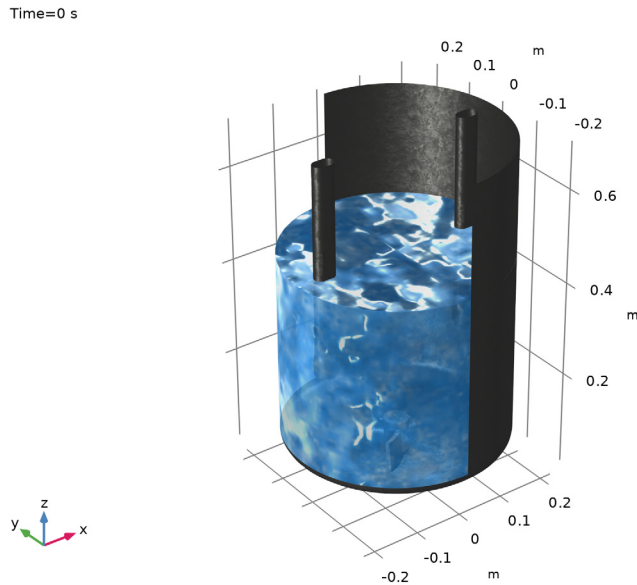

Figure 2: Water surface position at $t = 0$ s.

Time=3 s

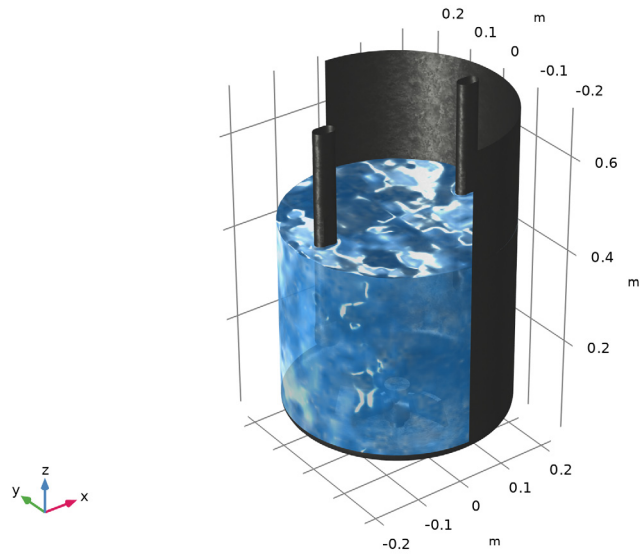

Figure 3: Water surface position at $t = 3.0$ s. The impeller is rotating at 187 rpm, but the rotation has not yet affected the shape of the free surface.

Time=4 s

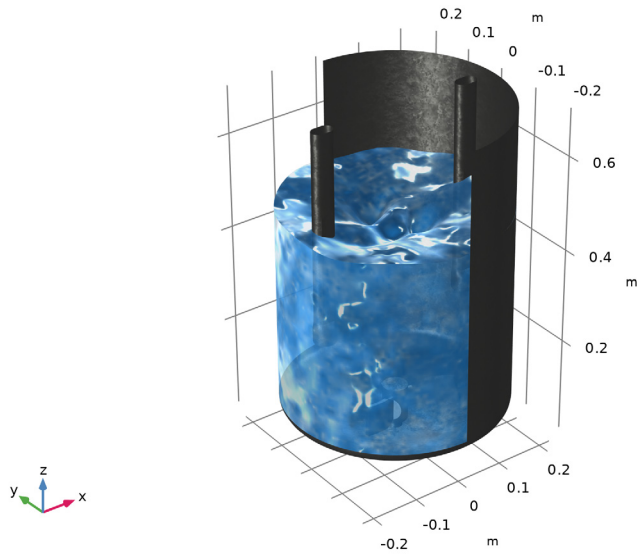

Figure 4: Water surface position at $t = 4.0$ s. The impeller is already rotating at 259 rpm, and the free surface has started to deform.

Time=4.3 s

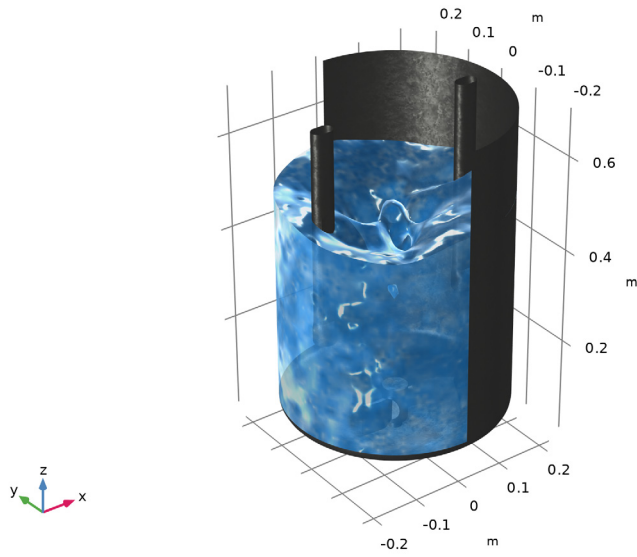

Figure 5: Water surface position at $t = 4.3$ s. The impeller is almost rotating at the maximum speed, and the free surface is forming a bath-tub vortex.

Time=4.5 s

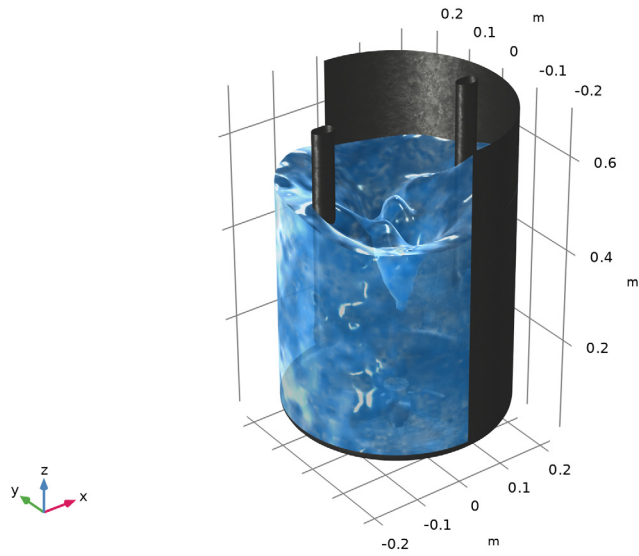

Figure 6: Water surface position at $t = 4.5$ s. The free surface has reached the impeller and the vortex remains semi-stable for about one second.

Time=5 s

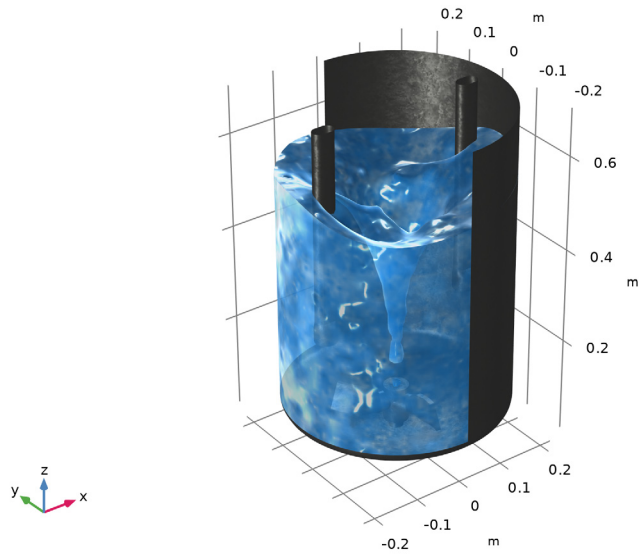

Figure 7: Water surface position at $t = 5.0$ s. The impeller has reached the maximum rotating velocity of 275 rpm. The vortex shape is fully developed and can be compared with experimental data.

Time=5.5 s

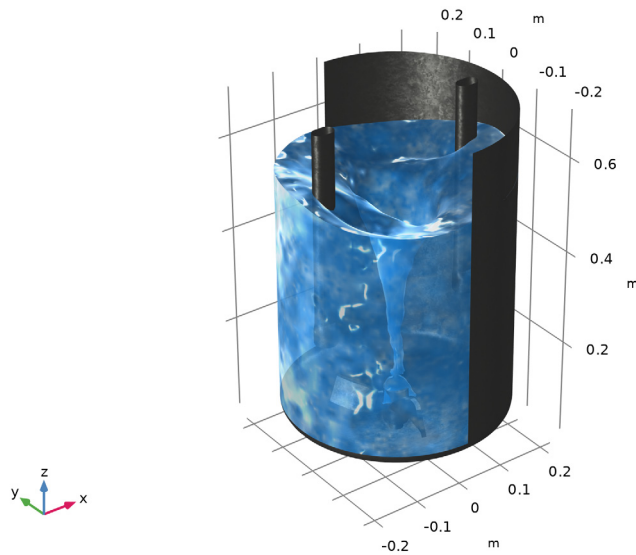

Figure 8: Water surface position at $t = 5.5$ s. The mixer has been rotating at constant velocity for 0.5 s and the vortex remains more or less stable. Should the model be simulated for longer time, the vortex shape would break at the impeller and air bubbles would be shed away.

Notes About the COMSOL Implementation

The present application uses the Block-Navier–Stokes preconditioner instead of the default preconditioner for GMRES when solving the Navier–Stokes equations. This preconditioner can uncouple the pressure and velocity equations when solving, and may provide faster solutions for large time-dependent incompressible models with high Reynolds numbers or low viscosities.

Reference

I. J.-P. Torr  and others, “An Experimental and Computational Study of the Vortex Shape in a Partially Baffled Agitated Vessel,” *Chem. Eng. Sci.*, vol. 62, no. 7, pp. 1915–1926, 2007.

Application Library path: Mixer_Module/Tutorials/free_surface_mixer_ls



Modeling Instructions

From the **File** menu, choose **New**.

NEW

In the **New** window, click  **Model Wizard**.

MODEL WIZARD

- 1 In the **Model Wizard** window, click  **3D**.
- 2 In the **Select Physics** tree, select **Fluid Flow > Multiphase Flow > Rotating Machinery, Two-Phase Flow, Level Set > Turbulent Flow > Turbulent Flow, k-ε**.
- 3 Click **Add**.
- 4 Click  **Study**.
- 5 In the **Select Study** tree, select **Preset Studies for Selected Multiphysics > Time Dependent with Phase Initialization**.
- 6 Click  **Done**.

GEOMETRY I

As the main focus will be on the physics and numerics, a detailed treatment of the geometry building procedure lies outside the scope of this tutorial. Instead, the geometry has been prepared in the file `free_surface_mixer_geom_sequence.mph`. You can start by inserting the geometry sequence from that file.

- 1 In the **Geometry** toolbar, click **Insert Sequence** and choose **Insert Sequence**.
- 2 Browse to the model's Application Libraries folder and double-click the file `free_surface_mixer_geom_sequence.mph`.
- 3 In the **Geometry** toolbar, click  **Build All**.

4 In the **Model Builder** window, under **Component 1 (comp1)** click **Geometry 1**.

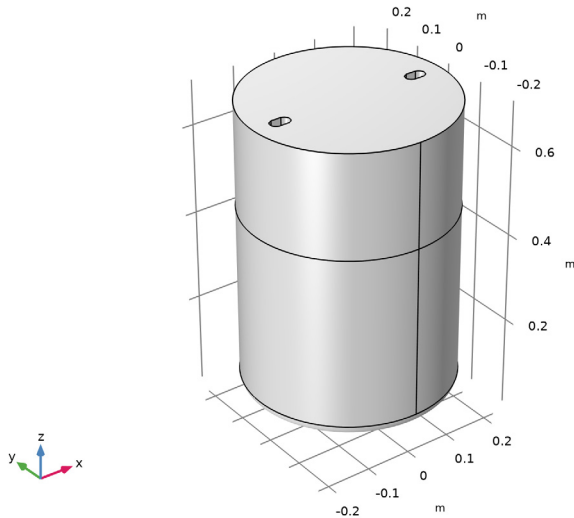

5 Click the  **Go to Default View** button in the **Graphics** toolbar.

6 Click the  **Transparency** button in the **Graphics** toolbar.

Define a step function to be used when ramping up the rotational velocity.

GLOBAL DEFINITIONS

Step 1 (step1)

1 In the **Home** toolbar, click  **Functions** and choose **Global > Step**.

2 In the **Settings** window for **Step**, locate the **Parameters** section.

3 In the **Location** text field, type 2.5.

4 Click to expand the **Smoothing** section. In the **Size of transition zone** text field, type 5.

MOVING MESH

Rotating Domain 1

1 In the **Model Builder** window, under **Component 1 (comp1)** > **Moving Mesh** click **Rotating Domain 1**.

2 In the **Settings** window for **Rotating Domain**, locate the **Domain Selection** section.

3 In the list, choose **1** and **2**.

4 Click  **Remove from Selection**.

- 5 Select Domain 3 only.
- 6 Locate the **Rotation** section. In the f text field, type $275[\text{rpm}] * \text{step1}(t[1/\text{s}])$.
- 7 Locate the **Axis** section. Specify the \mathbf{u}_{rot} vector as

0	X
0	Y
1	Z

Next, add a **Multiphase Material** to compute effective material properties, and define phase from the Material Library.

MULTIPHYSICS

Two-Phase Flow, Level Set 1 (tpfl)

- 1 In the **Model Builder** window, under **Component 1 (comp1) > Multiphysics** click **Two-Phase Flow, Level Set 1 (tpfl)**.
- 2 In the **Settings** window for **Two-Phase Flow, Level Set**, locate the **Material Properties** section.
- 3 Click  **Add Multiphase Material**.

MATERIALS

Phase 1 (mpmat1.phase1)

- 1 In the **Model Builder** window, under **Component 1 (comp1) > Materials > Multiphase Material 1 (mpmat1)** click **Phase 1 (mpmat1.phase1)**.
- 2 In the **Settings** window for **Phase**, locate the **Link Settings** section.
- 3 Click  **Add Material from Library**. This button is found when expanding the options next to the **Material** list.

ADD MATERIAL TO PHASE 1 (MPMAT1.PHASE1)

- 1 Go to the **Add Material to Phase 1 (mpmat1.phase1)** window.
- 2 In the tree, select **Built-in > Water, liquid**.
- 3 Click **Add Material**.

MATERIALS

Phase 2 (mpmat1.phase2)

- 1 In the **Model Builder** window, under **Component 1 (comp1) > Materials > Multiphase Material 1 (mpmat1)** click **Phase 2 (mpmat1.phase2)**.

- 2 In the **Settings** window for **Phase**, locate the **Link Settings** section.
- 3 Click  **Add Material from Library** . This button is found when expanding the options next to the **Material** list.

ADD MATERIAL TO PHASE 2 (MPMAT1.PHASE2)

- 1 Go to the **Add Material to Phase 2 (mpmat1.phase2)** window.
- 2 In the tree, select **Built-in > Air**.
- 3 Click **Add Material**.

MATERIALS

- 1 Click the  **Show More Options** button in the **Model Builder** toolbar.
- 2 In the **Show More Options** dialog, in the tree, select the checkbox for the node **Physics > Advanced Physics Options**.
- 3 Click **OK**.

TURBULENT FLOW, K-ε (SPF)

- 1 In the **Model Builder** window, under **Component 1 (comp1)** click **Turbulent Flow, k-ε (spf)**.
- 2 In the **Settings** window for **Turbulent Flow, k-ε**, locate the **Physical Model** section.
- 3 Select the **Include gravity** checkbox.
- 4 Click to expand the **Advanced Settings** section. Find the **Linear solver** subsection. Select the **Use Block Navier–Stokes preconditioner** checkbox. This preconditioner is efficient for time dependent incompressible flow problems.

Next, set up an initial pressure that accounts for the presence of both phases.

Initial Values 1

- 1 In the **Model Builder** window, under **Component 1 (comp1) > Turbulent Flow, k-ε (spf)** click **Initial Values 1**.
- 2 In the **Settings** window for **Initial Values**, locate the **Initial Values** section.
- 3 In the p text field, type $tpf1.rho2*g_const*(0.7[m]-z)*1s.Vf2+tpf1.rho1*g_const*(0.4667[m]-z)*1s.Vf1$.
- 4 Clear the **Compensate for hydrostatic pressure** checkbox.

Pressure Point Constraint 1

- 1 In the **Physics** toolbar, click  **Points** and choose **Pressure Point Constraint**.
- 2 Select Point 22 only.

- 3 In the **Settings** window for **Pressure Point Constraint**, locate the **Pressure Constraint** section.
- 4 Clear the **Compensate for hydrostatic pressure** checkbox.



LEVEL SET (LS)

Initial Values, Fluid 2

- 1 In the **Model Builder** window, under **Component 1 (comp1) > Level Set (ls)** click **Initial Values, Fluid 2**.
- 2 Select Domain 2 only.

MULTIPHYSICS

Wetted Wall, Automatic from frame

- 1 In the **Physics** toolbar, click  **Multiphysics Couplings** and choose **Boundary > Wetted Wall**.
- 2 In the **Settings** window for **Wetted Wall**, type Wetted Wall, Automatic from frame in the **Label** text field.
- 3 Locate the **Boundary Selection** section. From the **Selection** list, choose **Walls**.
- 4 In the list box, select **32**.
- 5 Click  **Remove from Selection**.

The **Translational velocity** is set per default to **Automatic from frame**. This means that the boundaries adjacent to the **Rotating Domain** will rotate due to the angular velocity. However, boundary 32 (the base of the mixer) is adjacent to the **Rotating Domain** but should not rotate. Add a new **Wetted Wall** feature and set the **Translational velocity** to **Zero (Fixed wall)**.

Wetted Wall, Fixed wall

- 1 In the **Physics** toolbar, click  **Multiphysics Couplings** and choose **Boundary > Wetted Wall**.
- 2 In the **Settings** window for **Wetted Wall**, type Wetted Wall, Fixed wall in the **Label** text field.
- 3 Select Boundary 32 only.
- 4 Locate the **Wall Movement** section. From the **Translational velocity** list, choose **Zero (Fixed wall)**.

MESH 1

- 1 In the **Model Builder** window, under **Component 1 (comp1)** click **Mesh 1**.

- 2 In the **Settings** window for **Mesh**, locate the **Physics-Controlled Mesh** section.
- 3 In the table, clear the **Use** checkbox for **Geometric Analysis, Detail Size**.
- 4 Locate the **Sequence Type** section. From the list, choose **User-controlled mesh**.

Size 1

In the **Model Builder** window, under **Component 1 (comp1) > Mesh 1** right-click **Size 1** and choose **Build Selected**.

Size 2

- 1 Right-click **Component 1 (comp1) > Mesh 1 > Size 1** and choose **Duplicate**.
- 2 In the **Settings** window for **Size**, locate the **Geometric Entity Selection** section.
- 3 From the **Selection** list, choose **Impeller Walls**.

Size 3

- 1 In the **Model Builder** window, right-click **Mesh 1** and choose **Size**.
- 2 In the **Settings** window for **Size**, locate the **Geometric Entity Selection** section.
- 3 From the **Geometric entity level** list, choose **Edge**.
- 4 Select Edges 9, 22, 40, and 53 only.
- 5 Locate the **Element Size** section. From the **Calibrate for** list, choose **Fluid dynamics**.
- 6 From the **Predefined** list, choose **Finer**.
- 7 Click  **Build All**.

STUDY 1

Step 2: Time Dependent

- 1 In the **Model Builder** window, under **Study 1** click **Step 2: Time Dependent**.
- 2 In the **Settings** window for **Time Dependent**, locate the **Study Settings** section.
- 3 In the **Output times** text field, type range (0, 0.1, 5.5).

Solution 1 (sol1)

- 1 In the **Study** toolbar, click  **Show Default Solver**.
- 2 In the **Model Builder** window, expand the **Solution 1 (sol1)** node.
- 3 In the **Model Builder** window, expand the **Study 1 > Solver Configurations > Solution 1 (sol1) > Dependent Variables 2** node, then click **Velocity Field (Spatial Frame) (comp1.u)**.
- 4 In the **Settings** window for **Field**, locate the **Scaling** section.
- 5 From the **Method** list, choose **Manual**.

- 6 In the **Scale** text field, type 10.
- 7 In the **Model Builder** window, under **Study 1 > Solver Configurations > Solution 1 (sol1)** click **Time-Dependent Solver 1**.
- 8 In the **Settings** window for **Time-Dependent Solver**, click to expand the **Time Stepping** section.
- 9 Find the **Algebraic variable settings** subsection. From the **Consistent initialization** list, choose **Off**.
The model starts with zero rotation velocity, so consistent initialization is not required.
- 10 Click  **Run**.

RESULTS

Velocity (spf)

- 1 In the **Model Builder** window, click **Results**.
- 2 In the **Settings** window for **Results**, locate the **Update of Results** section.
- 3 Select the **Only plot when requested** checkbox.

Water Free Surface

- 1 In the **Results** toolbar, click  **3D Plot Group**.
- 2 In the **Settings** window for **3D Plot Group**, type Water Free Surface in the **Label** text field.
- 3 Click to expand the **Title** section. From the **Title type** list, choose **Custom**.
- 4 Find the **Type and data** subsection. Clear the **Type** checkbox.
- 5 Clear the **Description** checkbox.
- 6 Clear the **Unit** checkbox.
- 7 Locate the **Plot Settings** section. Clear the **Plot dataset edges** checkbox.

Surface 1

Right-click **Water Free Surface** and choose **Surface**.

Selection 1

- 1 In the **Model Builder** window, right-click **Surface 1** and choose **Selection**.
- 2 In the **Settings** window for **Selection**, locate the **Selection** section.
- 3 From the **Selection** list, choose **Walls**.
- 4 In the list, choose **1** and **3**.
- 5 Click  **Remove from Selection**.

- 6 Select Boundaries 2, 8–29, and 32–69 only.

Material Appearance 1

- 1 In the **Model Builder** window, right-click **Surface 1** and choose **Material Appearance**.
- 2 In the **Settings** window for **Material Appearance**, locate the **Appearance** section.
- 3 From the **Appearance** list, choose **Custom**.
- 4 From the **Material type** list, choose **Iron (scratched)**.

Surface 2

- 1 In the **Model Builder** window, right-click **Water Free Surface** and choose **Surface**.
- 2 In the **Settings** window for **Surface**, click **Replace Expression** in the upper-right corner of the **Expression** section. From the menu, choose **Component 1 (comp1) > Level Set > Is.Vf1 - Volume fraction of fluid 1 - 1**.
- 3 Click to expand the **Range** section. Select the **Manual data range** checkbox.
- 4 In the **Minimum** text field, type 0.5.
- 5 In the **Maximum** text field, type 1.

Selection 1

- 1 Right-click **Surface 2** and choose **Selection**.
- 2 Select Boundaries 1, 3, and 5 only.

Material Appearance 1

- 1 In the **Model Builder** window, right-click **Surface 2** and choose **Material Appearance**.
- 2 In the **Settings** window for **Material Appearance**, locate the **Appearance** section.
- 3 From the **Appearance** list, choose **Custom**.
- 4 From the **Material type** list, choose **Water**.

Transparency 1

Right-click **Surface 2** and choose **Transparency**.

Isosurface 1

- 1 In the **Model Builder** window, right-click **Water Free Surface** and choose **Isosurface**.
- 2 In the **Settings** window for **Isosurface**, locate the **Expression** section.
- 3 In the **Expression** text field, type `Is.Vf1`.
- 4 Locate the **Levels** section. In the **Total levels** text field, type 1.

Material Appearance 1

- 1 Right-click **Isosurface 1** and choose **Material Appearance**.

- 2 In the **Settings** window for **Material Appearance**, locate the **Appearance** section.
- 3 From the **Appearance** list, choose **Custom**.
- 4 From the **Material type** list, choose **Water**.

Transparency I

- 1 In the **Model Builder** window, right-click **IsoSurface 1** and choose **Transparency**.
- 2 In the **Settings** window for **Transparency**, locate the **Transparency** section.
- 3 Find the **Transparency** subsection. Set the **Transparency** value to **0.15**.
- 4 In the **Water Free Surface** toolbar, click  **Plot**.

Water Free Surface

- 1 In the **Model Builder** window, under **Results** click **Water Free Surface**.
- 2 In the **Settings** window for **3D Plot Group**, locate the **Data** section.
- 3 From the **Time (s)** list, choose **5.5**.
- 4 In the **Water Free Surface** toolbar, click  **Plot**.