



Model created in COMSOL Multiphysics 6.4

# Lamella Mixer

## *Introduction*

---

At the macroscopic level, systems usually mix fluids using mechanical actuators or turbulent 3D flow. At the microscale level, however, neither of these approaches is practical or even possible. This model demonstrates the mixing of fluids using laminar-layered flow in a microfluidic mixer.

To characterize the fluid flow's turbulent behavior scientists generally use the Reynolds number

$$\text{Re} = \frac{\rho u L}{\mu}$$

where  $\rho$  is the fluid density,  $u$  is flow velocity,  $L$  is a characteristic length, and  $\mu$  is the fluid's dynamic viscosity. Turbulent flow takes place when the Reynolds number is high, typically when  $\text{Re} > 2000$ . At microfluidic scales, the width of a channel is in the range of  $100 \mu\text{m}$  and the velocity is approximately  $1 \text{ cm/s}$ . In this case, for water-like substances  $\text{Re}$  is close to unity. The fluid flow is thus clearly laminar, so effective mixing of fluids in microfluidic devices requires other means.

[Figure 1](#) shows a section of a component that uses layered flow to improve mixing. The mixer has several lamellae of microchannels, and the two fluids being mixed are alternated for every second layer. Pressure forces the fluid to travel in the channels from back to front. The fluid enters a larger space, the mixing chamber (visible at the front of the image). The figure does not include this chamber, but it covers the area beyond where the grid of the microchannel ends. Near the ends of the microchannels the mixing chamber has distinct lamellae of the two fluids, but this separation vanishes toward the end of the chamber.

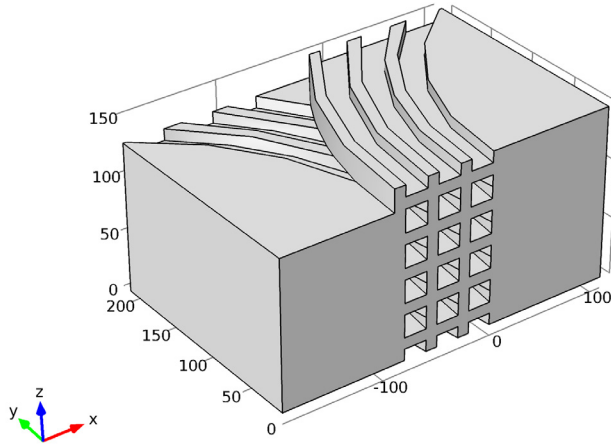

*Figure 1: Geometry of a lamella mixer (mixing chamber not visible).*

### *Model Definition*

---

This model analyzes the steady-state condition of the fluid flow as well as the convection and diffusion of a dissolved substance in a lamella mixer. The geometry in [Figure 2](#) corresponds to [Figure 1](#) except it includes only a small vertical section of the mixer with a height of  $30\ \mu\text{m}$ . The model starts from a plane in the middle of the channel bending to the left and ends at a plane in the middle of the channel bending to the right.

Each microchannel in the mixer has a quadratic cross section with a side of  $20\ \mu\text{m}$ . Because of the chosen geometry, microchannel height in the model is only  $10\ \mu\text{m}$ . The fluid exiting the microchannels enters a mixing chamber of length  $200\ \mu\text{m}$  and width  $80\ \mu\text{m}$ .

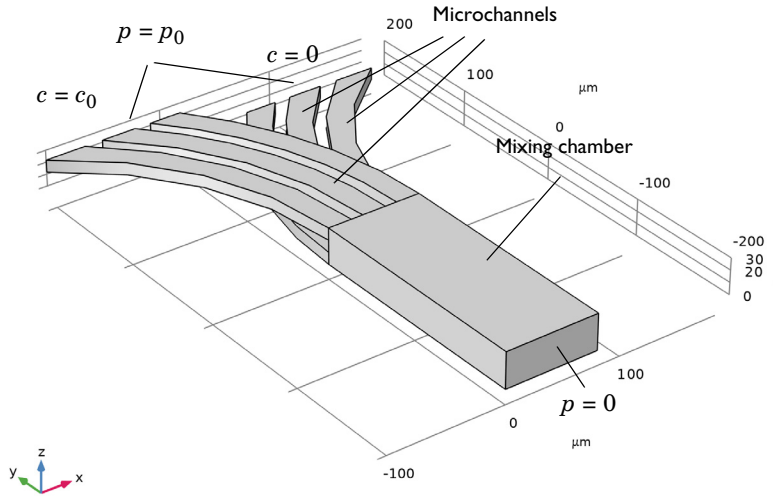

Figure 2: The model geometry for a lamella mixer takes advantage of symmetry so it is not necessary to model the entire height of the device.

You solve the fluid flow in the channels and in the chamber with the incompressible, steady Navier–Stokes equations

$$\begin{aligned} -\nabla \cdot [-p\mathbf{I} + \mu(\nabla\mathbf{u} + (\nabla\mathbf{u})^T)] + \rho\mathbf{u} \cdot \nabla\mathbf{u} &= \mathbf{F} \\ -\nabla \cdot \mathbf{u} &= 0 \end{aligned} \quad (1)$$

where  $\rho$  is fluid density,  $\mathbf{u} = (u, v, w)$  is the flow-velocity field,  $p$  is fluid pressure,  $\mathbf{I}$  is the unit diagonal matrix,  $\mu$  is the fluid's dynamic viscosity, and  $\mathbf{F} = (f_x, f_y, f_z)$  is a volume force affecting the fluid. The fluid is water with  $\rho = 1000 \text{ kg/m}^3$ ,  $\mu = 0.001 \text{ Pa}\cdot\text{s}$ , and  $\mathbf{F} = \mathbf{0}$  because there are no volume forces.

The system applies a pressure of  $p_0 = 10 \text{ Pa}$  on all six microchannel inputs to drive the flow through the mixing chamber to where there is zero pressure. At the chamber exit the flow velocity has components only in the normal direction of the boundary.

On the microchannel and mixing-chamber walls, the no slip boundary condition applies. However, in the vertical direction, due to the geometry, you can use a symmetry boundary condition.

The following steady convection–diffusion equation describes the concentration of the dissolved substances in the fluid:

$$\nabla \cdot (-D\nabla c) = R - \mathbf{u} \cdot \nabla c \quad (2)$$

where  $c$  is the concentration,  $D$  is the diffusion coefficient, and  $R$  is the reaction rate. In this model,  $D = 10^{-10} \text{ m}^2/\text{s}$ , and  $R = 0$  because the concentration is not affected by any reactions.

There is a concentration of  $c_0 = 50 \text{ mol/m}^3$  on the input boundaries of the channels curving to the left, whereas the channels curving to the right have zero concentration. At the output boundary of the mixing chamber the substance flows through the boundary by convection. The walls of the channels and the chamber are insulated for this dissolved substance, and on the top and bottom boundaries you use a symmetry boundary condition.

### *Results and Discussion*

---

[Figure 3](#) details fluid flow in the mixer. You can see a gradual change in the velocity magnitude across the slices, indicating a laminar parabolic flow. The streamlines do not show swirls, and there are only small changes in the flow direction. The figure also shows that the maximum flow velocity in the microchannels is at the model’s symmetry boundaries. Inside the mixing chamber, a flow velocity gradient is visible only along the  $x$  direction; the symmetry conditions on the top and bottom boundaries give a uniform velocity profile in the  $z$  direction.

The peak velocity is roughly  $1.3 \text{ mm/s}$  in the microchannels and  $0.6 \text{ mm/s}$  in the mixing chamber. Given the corresponding lengths ( $20 \text{ }\mu\text{m}$  and  $80 \text{ }\mu\text{m}$ ), the Reynolds numbers are  $\text{Re} = 0.026$  and  $\text{Re} = 0.048$ , so the flow is clearly laminar.

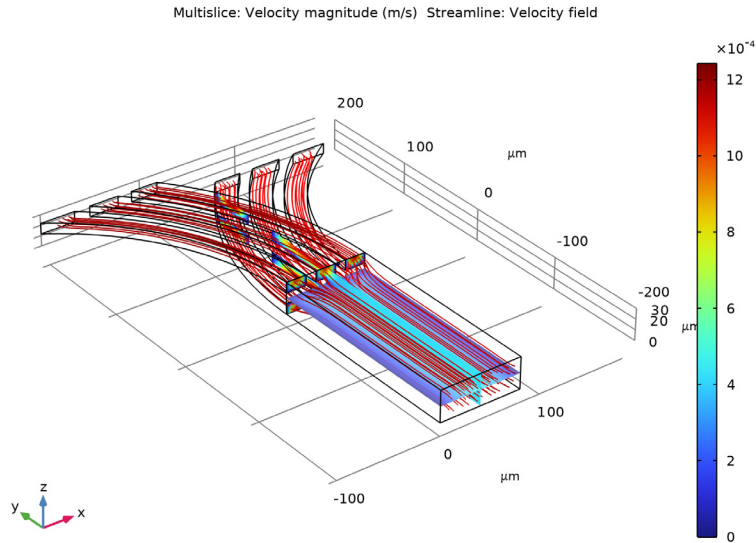

*Figure 3: Fluid flow in the lamella mixer.*

Figure 4 shows the concentration distribution on the model boundaries. The inflow channels see a constant concentration of 0 or  $50 \text{ mol/m}^3$  depending on the channel. Mixing starts when the fluid enters the mixing chamber. At the entrance there is a clear separation of the concentration, but this diminishes toward the end of the chamber. On the sides of the mixing chamber where the flow velocity is smaller the mixing is better than at its center. The mixing, however, is not perfect, and a reduced flow velocity, a longer mixing chamber, or some other means to increase mixing is preferable.

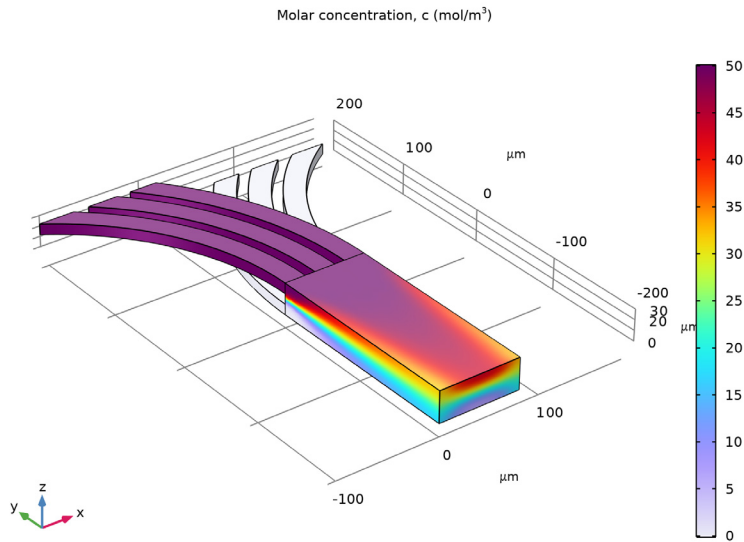

*Figure 4: Concentration plot on the boundaries of the lamella mixer model.*

To get another point of view, examine [Figure 5](#), which shows the concentration profile at the chamber's centerline. Near the channels the transition is very rapid, but closer to the chamber's end the profile has a flatter sigmoid shape. On the chamber's sides the concentration profile has the same shape, but its amplitude is between approximately  $17 \text{ mol}/\text{m}^3$  and  $32 \text{ mol}/\text{m}^3$ .

If you generalize the concentration profile to cover the entire component ([Figure 1](#)), the profile would be a wave-like curve where concentration would alternate between its minimum and maximum values with a spatial frequency related to the layer thickness.

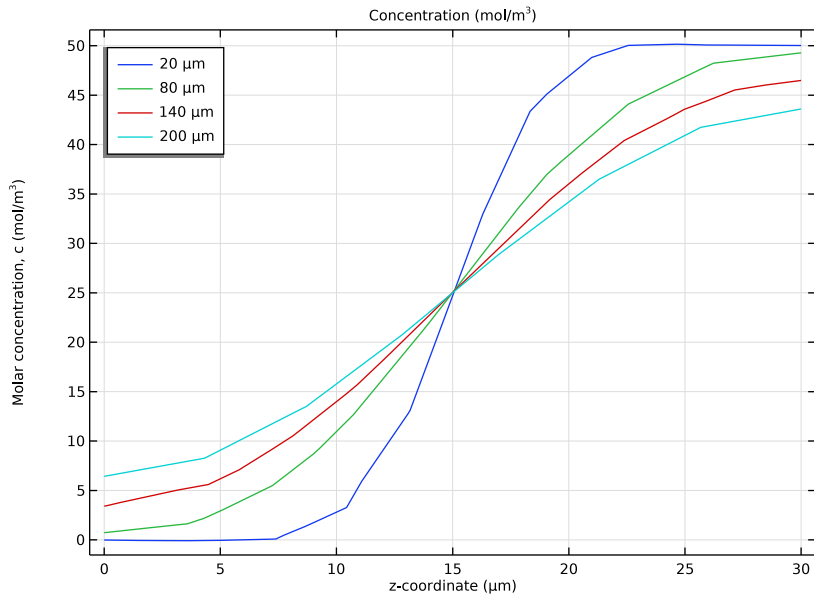

Figure 5: Concentration profile along a line in the  $z$  direction in the middle of the mixing chamber at various distances from the microchannels: 20  $\mu\text{m}$  (solid), 80  $\mu\text{m}$  (dotted), 140  $\mu\text{m}$  (dashed), and 200  $\mu\text{m}$  (dash-dotted).

### Notes About the COMSOL Implementation

---

Because the concentration does not affect the fluid flow, it is not necessary to solve the Laminar Flow and Transport of Diluted Species interfaces simultaneously. By solving them sequentially, starting with the Navier–Stokes equations, you improve the solution’s convergence and reduce the solution time.

---

**Application Library path:** Microfluidics\_Module/Micromixers/lamella\_mixer

---

### Modeling Instructions



---

From the **File** menu, choose **New**.

## NEW

In the **New** window, click  **Model Wizard**.

## MODEL WIZARD

- 1 In the **Model Wizard** window, click  **3D**.
- 2 In the **Select Physics** tree, select **Chemical Species Transport > Reacting Flow > Laminar Flow, Diluted Species**.
- 3 Click **Add**.
- 4 Click  **Study**.
- 5 In the **Select Study** tree, select **General Studies > Stationary**.
- 6 Click  **Done**.

## GEOMETRY I

For convenience, the device geometry is inserted from an existing file. You can read the instructions for creating the geometry in the [Appendix — Geometry Instructions](#).

- 1 In the **Geometry** toolbar, click **Insert Sequence** and choose **Insert Sequence**.
- 2 Browse to the model's Application Libraries folder and double-click the file `lamella_mixer_geom_sequence.mph`.
- 3 In the **Geometry** toolbar, click  **Build All**.

The dimensions of this geometry are given in micrometers, so check the length unit and change it accordingly if necessary.

## GLOBAL DEFINITIONS



### *Parameters I*

- 1 In the **Model Builder** window, under **Global Definitions** click **Parameters I**.
- 2 In the **Settings** window for **Parameters**, locate the **Parameters** section.
- 3 In the table, enter the following settings:

| Name | Expression               | Value                   | Description                     |
|------|--------------------------|-------------------------|---------------------------------|
| p0   | 10[Pa]                   | 10 Pa                   | Driving pressure                |
| c0   | 50[mol/m <sup>3</sup> ]  | 50 mol/m <sup>3</sup>   | Input concentration             |
| D_i  | 1e-10[m <sup>2</sup> /s] | 1E-10 m <sup>2</sup> /s | Isotropic diffusion coefficient |

Next, add a material for the fluid.

## ADD MATERIAL

- 1 In the **Materials** toolbar, click  **Add Material** to open the **Add Material** window.
- 2 Go to the **Add Material** window.
- 3 In the tree, select **Built-in > Water, liquid**.
- 4 Click the **Add to Component** button in the window toolbar.
- 5 In the **Materials** toolbar, click  **Add Material** to close the **Add Material** window.

## MATERIALS

*Water, liquid (mat1)*



You are now ready to set up the physics.

## LAMINAR FLOW (SPF)

*Inlet 1*

- 1 In the **Physics** toolbar, click  **Boundaries** and choose **Inlet**.
- 2 In the **Settings** window for **Inlet**, locate the **Boundary Selection** section.
- 3 From the **Selection** list, choose **Inlet**.
- 4 Locate the **Boundary Condition** section. From the list, choose **Pressure**.
- 5 Locate the **Pressure Conditions** section. In the  $p_0$  text field, type  $p_0$ .

*Symmetry 1*

- 1 In the **Physics** toolbar, click  **Boundaries** and choose **Symmetry**.
- 2 Click the  **Wireframe Rendering** button in the **Graphics** toolbar.
- 3 In the **Settings** window for **Symmetry**, locate the **Boundary Selection** section.
- 4 From the **Selection** list, choose **Symmetry**.

- 5 Click the  **Zoom Extents** button in the **Graphics** toolbar.

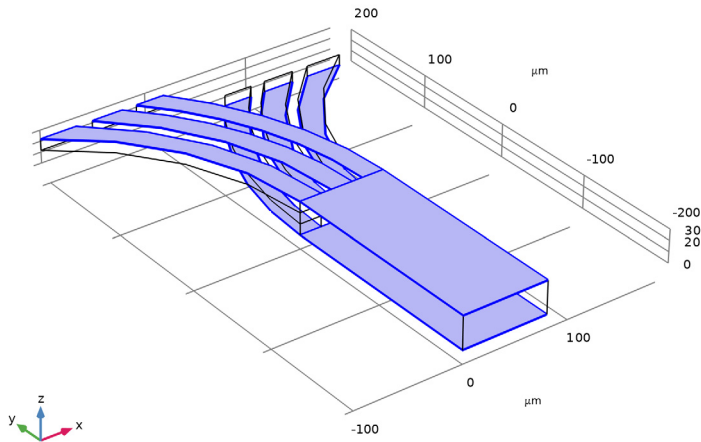

#### *Outlet 1*

- 1 In the **Physics** toolbar, click  **Boundaries** and choose **Outlet**.
- 2 In the **Settings** window for **Outlet**, locate the **Boundary Selection** section.
- 3 From the **Selection** list, choose **Outlet**.

There are two options available for the type of crosswind diffusion used to provide numerical stabilization. The default option, **Do Carmo and Galeao** is more effective at suppressing undershoots and overshoots in the concentration, whereas the second option, **Codina** produces less artificial diffusion in the crosswind direction.

#### **TRANSPORT OF DILUTED SPECIES (TDS)**

- 1 Click the  **Show More Options** button in the **Model Builder** toolbar.
- 2 In the **Show More Options** dialog, in the tree, select the checkbox for the node **Physics > Stabilization**.
- 3 Click **OK**.
- 4 In the **Model Builder** window, under **Component 1 (comp1)** click **Transport of Diluted Species (tds)**.
- 5 In the **Settings** window for **Transport of Diluted Species**, click to expand the **Consistent Stabilization** section.
- 6 From the **Crosswind diffusion type** list, choose **Codina**.

### *Fluid 1*

- 1 In the **Model Builder** window, under **Component 1 (comp1) > Transport of Diluted Species (tds)** click **Fluid 1**.
- 2 In the **Settings** window for **Fluid**, locate the **Diffusion** section.
- 3 In the  $D_c$  text field, type  $D_i$ .  
Note that the velocity field for the species convection is controlled by the **Reacting Flow, Diluted Species** multiphysics coupling.



### *Concentration 1*

- 1 In the **Physics** toolbar, click  **Boundaries** and choose **Concentration**.
- 2 In the **Settings** window for **Concentration**, locate the **Boundary Selection** section.
- 3 From the **Selection** list, choose **Concentration 1**.
- 4 Locate the **Concentration** section. Select the **Species c** checkbox.
- 5 In the  $c_{0,c}$  text field, type  $c_0$ .

### *Concentration 2*

- 1 In the **Physics** toolbar, click  **Boundaries** and choose **Concentration**.
- 2 In the **Settings** window for **Concentration**, locate the **Boundary Selection** section.
- 3 From the **Selection** list, choose **Concentration 2**.
- 4 Locate the **Concentration** section. Select the **Species c** checkbox.  
Leave the concentration at its default zero value.

### *Outflow 1*

- 1 In the **Physics** toolbar, click  **Boundaries** and choose **Outflow**.
- 2 In the **Settings** window for **Outflow**, locate the **Boundary Selection** section.
- 3 From the **Selection** list, choose **Outlet**.
- 4 Click the  **Wireframe Rendering** button in the **Graphics** toolbar.

## **MESH 1**

### *Free Tetrahedral 1*

In the **Mesh** toolbar, click  **Free Tetrahedral**.

### *Size*

- 1 In the **Model Builder** window, click **Size**.
- 2 In the **Settings** window for **Size**, locate the **Element Size** section.
- 3 From the **Calibrate for** list, choose **Fluid dynamics**.

4 From the **Predefined** list, choose **Fine**.

5 Click  **Build All**.

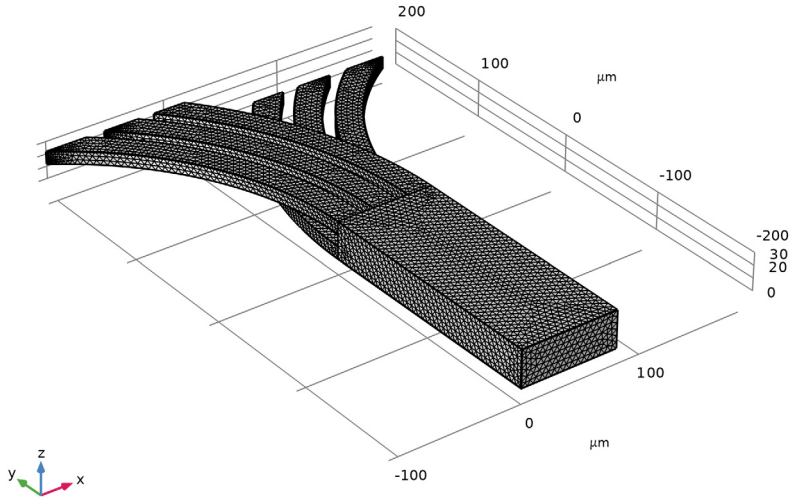

## STUDY 1

In the **Study** toolbar, click  **Compute**.

## RESULTS

The following instructions show how to reproduce the plots in the [Results and Discussion](#) section.

### *Streamline 1*

- 1 In the **Model Builder** window, right-click **Velocity (spf)** and choose **Streamline**.
- 2 In the **Settings** window for **Streamline**, locate the **Streamline Positioning** section.
- 3 From the **Positioning** list, choose **Magnitude controlled**.
- 4 In the **Minimum density level** text field, type 11.
- 5 In the **Maximum density level** text field, type 13.4.
- 6 In the **Velocity (spf)** toolbar, click  **Plot**.



Compare the result with the plot in [Figure 3](#).

### Concentration, Surface (tds)

The second of the two default concentration plots shows the concentration on the modeling domain's boundary; compare with [Figure 4](#).

To reproduce [Figure 5](#), showing the concentration as a function of  $z$  at four different  $y$  positions along the mixing chamber, begin by creating four **Cut Line 3D** datasets. The possibility to duplicate model-tree nodes simplifies the procedure considerably.

#### Cut Line 3D 1

- 1 In the **Results** toolbar, click  **Cut Line 3D**.
- 2 In the **Settings** window for **Cut Line 3D**, locate the **Line Data** section.
- 3 In row **Point 1**, set **x** to 40 and **y** to -20.
- 4 In row **Point 2**, set **x** to 40, **y** to -20, and **z** to 30.
- 5 Click  **Plot**.
- 6 Click the  **Zoom In** button in the **Graphics** toolbar.

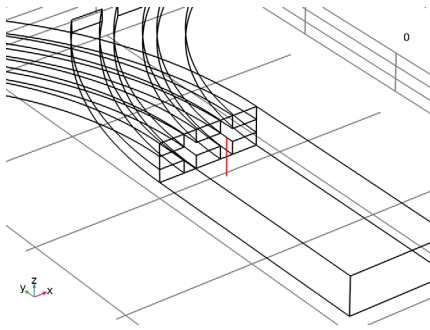

- 7 Click the  **Zoom Extents** button in the **Graphics** toolbar.

#### Cut Line 3D 2

- 1 Right-click **Cut Line 3D 1** and choose **Duplicate**.
- 2 In the **Settings** window for **Cut Line 3D**, locate the **Line Data** section.
- 3 In row **Point 1**, set **y** to -80.
- 4 In row **Point 2**, set **y** to -80.  
Leave the  $x$  and  $z$  values unchanged.

#### Cut Line 3D 3

- 1 Right-click **Cut Line 3D 2** and choose **Duplicate**.
- 2 In the **Settings** window for **Cut Line 3D**, locate the **Line Data** section.
- 3 In row **Point 1**, set **y** to -140.

4 In row **Point 2**, set **y** to -140.

#### *Cut Line 3D 4*

- 1 Right-click **Cut Line 3D 3** and choose **Duplicate**.
- 2 In the **Settings** window for **Cut Line 3D**, locate the **Line Data** section.
- 3 In row **Point 1**, set **y** to -200.
- 4 In row **Point 2**, set **y** to -200.

#### *ID Plot Group 5*

- 1 In the **Results** toolbar, click  **ID Plot Group**.
- 2 In the **Settings** window for **ID Plot Group**, locate the **Legend** section.
- 3 From the **Position** list, choose **Upper left**.
- 4 Click to expand the **Title** section. From the **Title type** list, choose **Manual**.
- 5 In the **Title** text area, type Concentration (mol/m<sup>3</sup>).  
Note the use of HTML tags to get superscript text.

#### *Line Graph 1*

- 1 Right-click **ID Plot Group 5** and choose **Line Graph**.
- 2 In the **Settings** window for **Line Graph**, locate the **Data** section.
- 3 From the **Dataset** list, choose **Cut Line 3D 1**.
- 4 Click **Replace Expression** in the upper-right corner of the **y-Axis Data** section. From the menu, choose **Component 1 (comp1) > Transport of Diluted Species > Species c > c - Molar concentration, c - mol/m<sup>3</sup>**.
- 5 Click **Replace Expression** in the upper-right corner of the **x-Axis Data** section. From the menu, choose **Component 1 (comp1) > Geometry > Coordinate > z - z-coordinate**.
- 6 Click to expand the **Legends** section. Select the **Show legends** checkbox.
- 7 From the **Legends** list, choose **Manual**.
- 8 In the table, enter the following settings:

---

| <b>Legends</b> |
|----------------|
| 20 μm          |

---

To enter the character 'μ', copy the Unicode character u00b5 from an external tool (such as the Character Map in Windows) and paste into the table.

#### *Line Graph 2*

- 1 Right-click **Line Graph 1** and choose **Duplicate**.

- 2 In the **Settings** window for **Line Graph**, locate the **Data** section.
- 3 From the **Dataset** list, choose **Cut Line 3D 2**.
- 4 Locate the **Legends** section. In the table, enter the following settings:

| <b>Legends</b>   |
|------------------|
| 80 $\mu\text{m}$ |

#### *Line Graph 3*

- 1 Right-click **Line Graph 2** and choose **Duplicate**.
- 2 In the **Settings** window for **Line Graph**, locate the **Data** section.
- 3 From the **Dataset** list, choose **Cut Line 3D 3**.
- 4 Locate the **Legends** section. In the table, enter the following settings:

| <b>Legends</b>    |
|-------------------|
| 140 $\mu\text{m}$ |

#### *Line Graph 4*

- 1 Right-click **Line Graph 3** and choose **Duplicate**.
- 2 In the **Settings** window for **Line Graph**, locate the **Data** section.
- 3 From the **Dataset** list, choose **Cut Line 3D 4**.
- 4 Locate the **Legends** section. In the table, enter the following settings:

| <b>Legends</b>    |
|-------------------|
| 200 $\mu\text{m}$ |

- 5 In the **ID Plot Group 5** toolbar, click  **Plot**.  
Compare the result with [Figure 5](#).

## *Appendix — Geometry Instructions*

---

From the **File** menu, choose **New**.

### **NEW**

In the **New** window, click  **Blank Model**.

### **ADD COMPONENT**

In the **Home** toolbar, click  **Add Component** and choose **3D**.

## GEOMETRY I

- 1 In the **Settings** window for **Geometry**, locate the **Units** section.
- 2 From the **Length unit** list, choose **µm**.

### *Block 1 (blk1)*

- 1 In the **Geometry** toolbar, click  **Block**.
- 2 In the **Settings** window for **Block**, locate the **Size and Shape** section.
- 3 In the **Width** text field, type 80.
- 4 In the **Depth** text field, type 200.
- 5 In the **Height** text field, type 30.
- 6 Locate the **Position** section. In the **y** text field, type -200.

### *Work Plane 1 (wp1)*

In the **Geometry** toolbar, click  **Work Plane**.

### *Work Plane 1 (wp1) > Plane Geometry*

In the **Model Builder** window, click **Plane Geometry**.

### *Work Plane 1 (wp1) > Circle 1 (c1)*

- 1 In the **Work Plane** toolbar, click  **Circle**.
- 2 In the **Settings** window for **Circle**, locate the **Size and Shape** section.
- 3 In the **Radius** text field, type 320.
- 4 In the **Sector angle** text field, type 90.
- 5 Locate the **Position** section. In the **xw** text field, type 320.
- 6 Locate the **Rotation Angle** section. In the **Rotation** text field, type 90.
- 7 Click to expand the **Layers** section. In the table, enter the following settings:



| Layer name | Thickness (µm) |
|------------|----------------|
| Layer 1    | 20             |
| Layer 2    | 10             |
| Layer 3    | 20             |
| Layer 4    | 10             |
| Layer 5    | 20             |

### *Work Plane 1 (wp1) > Rectangle 1 (r1)*

- 1 In the **Work Plane** toolbar, click  **Rectangle**.
- 2 In the **Settings** window for **Rectangle**, locate the **Size and Shape** section.

- 3 In the **Width** text field, type 320.
- 4 In the **Height** text field, type 200.

*Work Plane 1 (wp1) > Intersection 1 (int1)*

- 1 In the **Work Plane** toolbar, click  **Booleans and Partitions** and choose **Intersection**.
- 2 Click in the **Graphics** window and then press Ctrl+A to select both objects.
- 3 In the **Settings** window for **Intersection**, click  **Build Selected**.

*Work Plane 1 (wp1) > Delete Entities 1 (dell)*

- 1 In the **Work Plane** toolbar, click  **Delete**.
- 2 In the **Settings** window for **Delete Entities**, locate the **Entities or Objects to Delete** section.
- 3 From the **Geometric entity level** list, choose **Domain**.
- 4 On the object **int1**, select Domains 2, 4, and 6 only.

*Extrude 1 (ext1)*

- 1 In the **Model Builder** window, under **Component 1 (comp1) > Geometry 1** right-click **Work Plane 1 (wp1)** and choose **Extrude**.
- 2 In the **Settings** window for **Extrude**, locate the **Distances** section.
- 3 In the table, enter the following settings:

| <b>Distances (µm)</b> |
|-----------------------|
| 10                    |

*Copy 1 (copy1)*

- 1 In the **Geometry** toolbar, click  **Transforms** and choose **Copy**.
- 2 Select the object **ext1** only.
- 3 In the **Settings** window for **Copy**, locate the **Displacement** section.
- 4 In the **z** text field, type 20.

*Mirror 1 (mir1)*

- 1 In the **Geometry** toolbar, click  **Transforms** and choose **Mirror**.
- 2 Select the object **copy1** only.
- 3 In the **Settings** window for **Mirror**, locate the **Point on Plane of Reflection** section.
- 4 In the **x** text field, type 40.
- 5 Locate the **Normal Vector to Plane of Reflection** section. In the **x** text field, type 1.
- 6 In the **z** text field, type 0.

### *Union 1 (uni1)*

- 1 In the **Geometry** toolbar, click  **Booleans and Partitions** and choose **Union**.
- 2 Click in the **Graphics** window and then press Ctrl+A to select all objects.
- 3 In the **Settings** window for **Union**, locate the **Union** section.
- 4 Clear the **Keep interior boundaries** checkbox.



### *Form Union (fin)*

- 1 In the **Model Builder** window, click **Form Union (fin)**.
- 2 In the **Settings** window for **Form Union/Assembly**, click  **Build Selected**.

### *Geometry*

- 1 In the **Geometry** toolbar, click  **Selections** and choose **Explicit Selection**.
- 2 On the object **fin**, select Domain 1 only.
- 3 In the **Settings** window for **Explicit Selection**, type Geometry in the **Label** text field.

### *All Walls*

- 1 In the **Geometry** toolbar, click  **Selections** and choose **Adjacent Selection**.
- 2 In the **Settings** window for **Adjacent Selection**, type All Walls in the **Label** text field.
- 3 Locate the **Input Entities** section. Click  **Add**.
- 4 In the **Add** dialog, select **Geometry** in the **Input selections** list.
- 5 Click **OK**.

### *Outlet*

- 1 In the **Geometry** toolbar, click  **Selections** and choose **Explicit Selection**.
- 2 In the **Settings** window for **Explicit Selection**, type Outlet in the **Label** text field.
- 3 Locate the **Entities to Select** section. From the **Geometric entity level** list, choose **Boundary**.
- 4 On the object **fin**, select Boundary 16 only.



### *Concentration 1*

- 1 In the **Geometry** toolbar, click  **Selections** and choose **Explicit Selection**.
- 2 In the **Settings** window for **Explicit Selection**, type Concentration 1 in the **Label** text field.
- 3 Locate the **Entities to Select** section. From the **Geometric entity level** list, choose **Boundary**.
- 4 On the object **fin**, select Boundaries 1, 6, and 11 only.

### *Concentration 2*

- 1 In the **Geometry** toolbar, click  **Selections** and choose **Explicit Selection**.
- 2 In the **Settings** window for **Explicit Selection**, type Concentration 2 in the **Label** text field.
- 3 Locate the **Entities to Select** section. From the **Geometric entity level** list, choose **Boundary**.
- 4 On the object **fin**, select Boundaries 32, 35, and 36 only.



### *Inlet*

- 1 In the **Geometry** toolbar, click  **Selections** and choose **Union Selection**.
- 2 In the **Settings** window for **Union Selection**, type Inlet in the **Label** text field.
- 3 Locate the **Geometric Entity Level** section. From the **Level** list, choose **Boundary**.
- 4 Locate the **Input Entities** section. Click  **Add**.
- 5 In the **Add** dialog, in the **Selections to add** list, choose **Concentration 1** and **Concentration 2**.
- 6 Click **OK**.

### *Symmetry*

- 1 In the **Geometry** toolbar, click  **Selections** and choose **Explicit Selection**.
- 2 In the **Settings** window for **Explicit Selection**, type Symmetry in the **Label** text field.
- 3 Locate the **Entities to Select** section. From the **Geometric entity level** list, choose **Boundary**.
- 4 Select the **Group by continuous tangent** checkbox.
- 5 On the object **fin**, select Boundaries 4, 9, 14, 17, 18, 20, 26, and 30 only.

### *Exterior Walls*

- 1 In the **Geometry** toolbar, click  **Selections** and choose **Difference Selection**.
- 2 In the **Settings** window for **Difference Selection**, type Exterior Walls in the **Label** text field.
- 3 Locate the **Geometric Entity Level** section. From the **Level** list, choose **Boundary**.
- 4 Locate the **Input Entities** section. Click the  **Add** button for **Selections to add**.
- 5 In the **Add** dialog, select **All Walls** in the **Selections to add** list.
- 6 Click **OK**.
- 7 In the **Settings** window for **Difference Selection**, locate the **Input Entities** section.
- 8 Click the  **Add** button for **Selections to subtract**.

- 9** In the **Add** dialog, in the **Selections to subtract** list, choose **Outlet**, **Inlet**, and **Symmetry**.
- 10** Click **OK**.