



Model created in COMSOL Multiphysics 6.4

Electroosmotic Micromixer¹

1. This model is courtesy of H. Chen, Y. T. Zhang, I. Mezić, C. D. Meinhart, and L. Petzold of the University of California, Santa Barbara ([Ref. 1](#) and [Ref. 2](#)).

Introduction

Microlaboratories for biochemical applications often require rapid mixing of different fluid streams. At the microscale, flow is usually highly ordered laminar flow, and the lack of turbulence makes diffusion the primary mechanism for mixing. While diffusional mixing of small molecules (and therefore of rapidly diffusing species) can occur in a matter of seconds over distances of tens of micrometers, mixing of larger molecules such as peptides, proteins, and high molecular-weight nucleic acids can require equilibration times from minutes to hours over comparable distances. Such delays are impractically long for many chemical analyses. These problems have led to an intense search for more efficient mixers for microfluidic systems.

Most microscale mixing devices are either passive mixers that use geometrical stirring, or active mixers that use moving parts or external forces, such as pressure or electric field.

In a passive mixer, one way of increasing the mixing is by “shredding” two or several fluids into very thin alternating layers, which decreases the average diffusion length for the molecules between the different fluids. However, these mixers often require very long mixing channels because the different fluids often run in parallel. Another way of improving mixing efficiency is to use active mixers with moving parts that stir the fluids. At the microscale level moving parts in an active mixer are very fragile. One alternative is to use electroosmotic effects to achieve a mixing effect that is perpendicular to the main direction of the flow.

This model takes advantage of electroosmosis to mix fluids. The system applies a time-dependent electric field, and the resulting electroosmosis perturbs the parallel streamlines in the otherwise highly ordered laminar flow.

Model Definition

This example of a rather simple micromixer geometry ([Figure 1](#)) combines two fluids entering from different inlets into a single 10 μm wide channel. The fluids then enter a ring-shaped mixing chamber that has four microelectrodes placed on the outer wall at angular positions of 45, 135, -45 , and -135 degrees, respectively. Assume that the aspect ratio (channel depth to width) is large enough that you can model the mixer using a 2D

cross-sectional geometry. The material parameters relevant for the model are given in Table 1.

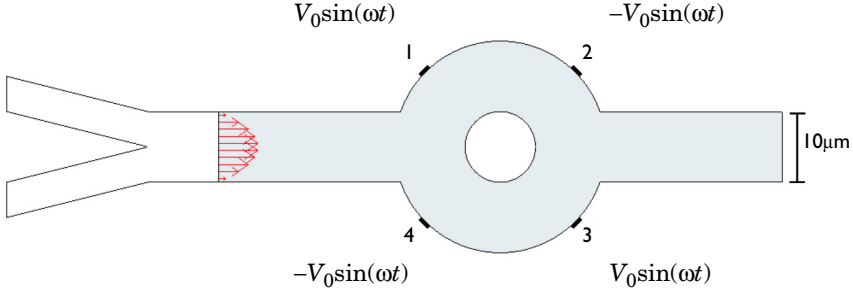

Figure 1: Geometry of the micromixer with four symmetric electrodes on the wall of the mixing chamber. This example does not model the two inlet channels. Here you assume a parabolic inflow at the beginning of the computational domain (the gray area).

The Navier–Stokes equations for incompressible flow describe the flow in the channels:

$$\rho \frac{\partial \mathbf{u}}{\partial t} - \nabla \cdot \eta (\nabla \mathbf{u} + (\nabla \mathbf{u})^T) + \rho \mathbf{u} \cdot \nabla \mathbf{u} + \nabla p = 0$$

$$\nabla \cdot \mathbf{u} = 0$$

Here η denotes the dynamic viscosity (SI unit: kg/(m·s)), \mathbf{u} is the velocity (SI unit: m/s), ρ equals the fluid density (SI unit: kg/m³), and p refers to the pressure (SI unit: Pa).

Because you do not model the two inlet channels, assume that the entrance channel starts at a position where the flow has a fully developed laminar profile. The mixed fluid flows freely out of the right end boundary, where you specify vanishing total stress components normal to the boundary:

$$\mathbf{n} \cdot [-p\mathbf{I} + \eta(\nabla \mathbf{u} + (\nabla \mathbf{u})^T)] = \mathbf{0}$$

When brought into contact with an electrolyte, most solid surfaces acquire a surface charge. In response to the spontaneously formed surface charge, a charged solution forms close to the liquid-solid interface. Known as an electric double layer, it forms because of the charged groups located on the surface that faces the solution. When the operator applies an electric field, the electric field generating the electroosmotic flow displaces the charged liquid in the electric double layer. This scheme imposes a force on the positively charged solution close to the wall surface, and the fluid starts to flow in the direction of the electric field. The velocity gradients perpendicular to the wall give rise to viscous

transport in this direction. In the absence of other forces, the velocity profile eventually becomes almost uniform in the cross section perpendicular to the wall.

This model replaces the thin electric double layer with the Helmholtz–Smoluchowski relation between the electroosmotic velocity and the tangential component of the applied electric field:

$$\mathbf{u} = \frac{\varepsilon_w \zeta_0}{\eta} \nabla_T V$$

In this equation, $\varepsilon_w = \varepsilon_0 \varepsilon_r$ denotes the fluid’s electric permittivity (F/m), ζ_0 represents the zeta potential at the channel wall (V), and V equals the potential (V). This equation applies on all boundaries except for the entrance and the outlet.

Assuming that there are no concentration gradients in the ions that carry the current, you can express the current balance in the channel with Ohm’s law and the balance equation for current density

$$\nabla \cdot (-\sigma \nabla V) = 0$$

where σ denotes conductivity (S/m) and the expression within parentheses represents the current density (A/m^2).

The electric potentials on the four electrodes are sinusoidal in time with the same maximum value ($V_0 = 0.1$ V) and the same frequency (8 Hz), but they alternate in polarity. The potentials on electrodes 1 and 3 are $V_0 \sin(2\pi ft)$, whereas those on electrodes 2 and 4 are $-V_0 \sin(2\pi ft)$ (see [Figure 1](#)).

Assume all other boundaries are insulated. The insulation boundary condition

$$-\sigma \nabla V \cdot \mathbf{n} = 0$$

sets the normal component of the electric field to zero.

At the upper half of the inlet (see [Figure 1](#)) the solute has a given concentration, c_0 ; at the lower half the concentration is zero. Thus, assume that the concentration changes abruptly from zero to c_0 at the middle of the inlet boundary. The mixed solution flows out from the right outlet by convection, and all other boundaries are assumed insulated.

Inside the mixer, the following convection–diffusion equation describes the concentration of the dissolved substances in the fluid:

$$\frac{\partial c}{\partial t} + \nabla \cdot (-D \nabla c) = R - \mathbf{u} \cdot \nabla c$$

Here c is the concentration, D represents the diffusion coefficient, R denotes the reaction rate, and \mathbf{u} equals the flow velocity. In this model $R = 0$ because the concentration is not affected by any reactions.

TABLE I: MODEL INPUT DATA.

Parameter	Value	Description
ρ	1000 kg/m ³	Density of the fluid
η	10 ⁻³ Pa·s	Dynamic viscosity of the fluid
U_0	0.1 mm/s	Average velocity through the inlet
ϵ_r	80.2	Relative electric permittivity of the fluid
ζ	-0.1 V	Zeta potential on the wall-fluid boundary
σ	0.11845 S/m	Conductivity of the ionic solution
D	10 ⁻¹¹ m ² /s	Diffusion coefficient
c_0	1 mol/m ³	Initial concentration

Results and Discussion

Figure 2 shows a typical instantaneous streamline pattern. It reveals that electroosmotic recirculation of the fluid vigorously stirs the flow, typically in the form of two rotating vortices near the electrodes.

The fundamental processes of effective mixing involve a combination of repeated stretching and folding of fluid elements in combination with diffusion at small scales. As the system applies the AC field (Figure 3), the resulting electroosmotic flow perturbs the laminar pressure-driven flow such that it pushes the combined stream pattern up and down at the beginning of the mixing chamber, causing extensive folding and stretching of material lines.

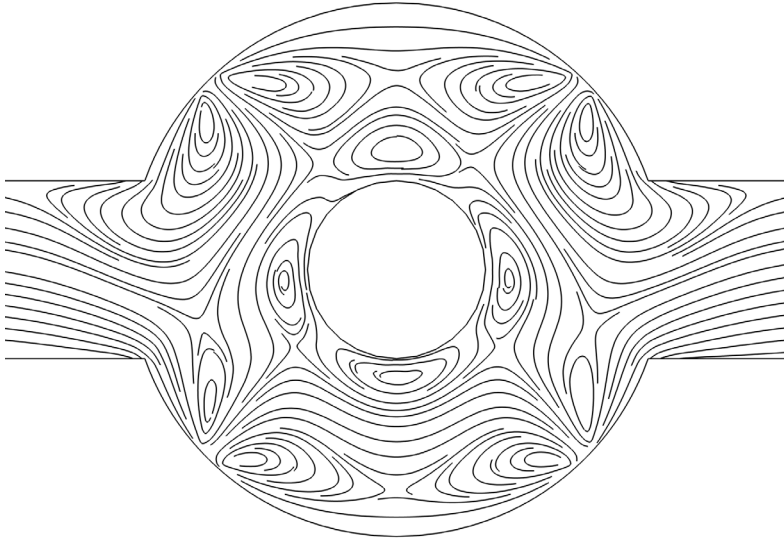

Figure 2: Fluid streamlines in an electroosmotic micromixer at $t = 0.0375$ s.

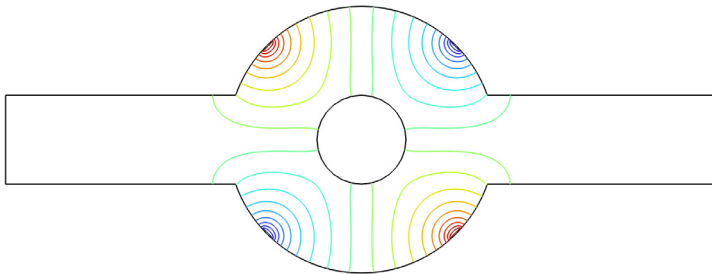

Figure 3: Electric potential lines for an electroosmotic micromixer. The contour lines show the shape when the device uses maximal potentials ($\pm V_0$).

The following plots further exemplify how the mixer operates. Figure 4 shows the concentration at steady state when the electric field is not applied. The flow is laminar and the diffusion coefficient is very small, so the two fluids are well separated also at the outlet. When the alternating electric field is applied, the mixing increases considerably owing to the alternating swirls in the flow. Figure 5 depicts the system at the instant when the electric field and the electroosmotic velocity have their largest magnitudes during the cycle (that is, when $|\sin \omega t| = 1$). From the plot you can estimate that the concentration at the outlet fluctuates with the same frequency as the electric field. Thus, this mixer should be further improved to get a steadier output.

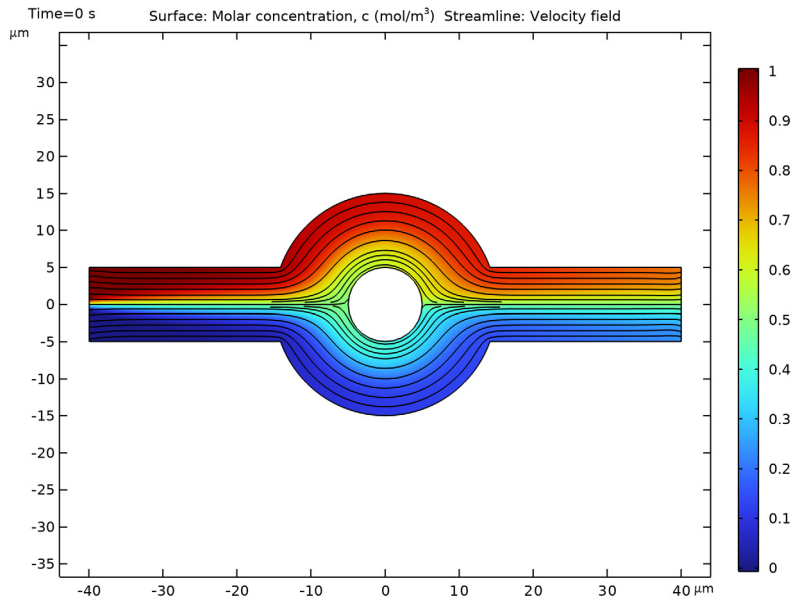

Figure 4: Steady-state solution in the absence of an electric field.

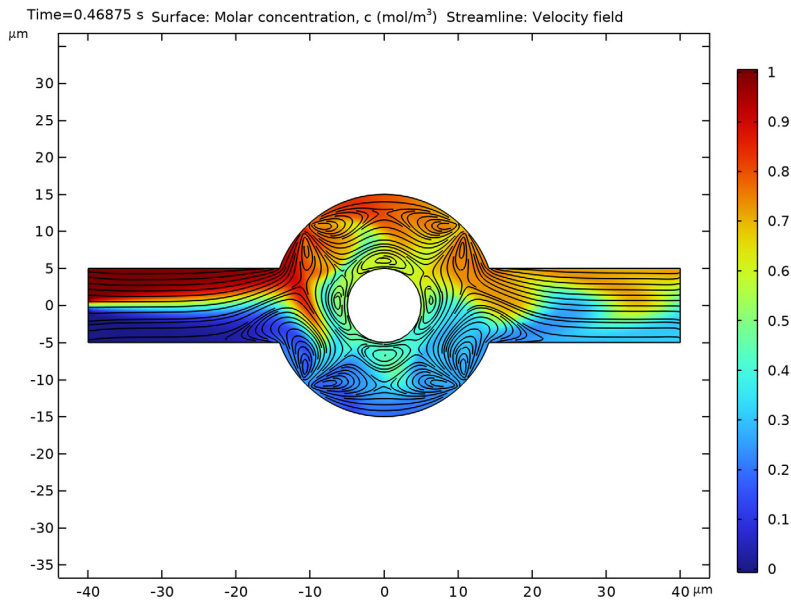

Figure 5: Time-dependent solution at the time when the alternating electric field has its largest magnitude.

This example demonstrates a rather simple and effective use of electrokinetic forces for mixing. The scheme is easy to implement, and you can easily control both the amplitude and the frequency. At low Reynolds numbers the inertial forces are small, which makes it possible to calculate stationary streamlines patterns using the parametric solver to control amplitude.

Notes About the COMSOL Implementation

Cummings and others (Ref. 3) have shown that in order to use the Helmholtz–Smoluchowski equation at the fluid–solid boundaries, the electric field must be at least quasistatic to neglect transient effects. In other words, the time scale of the unsteady electric field must be much larger than that of the transient flow. Y.T. Zhang and others (Ref. 1) estimated that the time scale of the transient effect in the modeled micromixer (with a channel width of 10 microns) is roughly 0.0127 s. In this simulation, the frequency of the applied electric potential is 8 Hz, which corresponds to a time scale of the electric field 10 times larger than that of the flow.

Because you can model the time-dependent electric field as a product of a stationary electric field and a time-dependent phase factor ($\sin\omega t$), it is possible to reduce the simulation time and memory requirements by dividing the solution into two stages. In the first, calculate the amplitude of the electric potential field and the initial state for the time-dependent flow model using a stationary solver. In the second stage, you deactivate the Electric Currents interface and calculate the transient solution for the Laminar Flow and the Transport of Diluted Species interfaces. You obtain the tangential electric field components used in the electroosmotic velocity boundary condition by multiplying the stationary DC solution by $\sin(\omega t)$. This approach is permissible because there is only a unidirectional dependence between the electric field and the fluid fields.

References

1. H. Chen, Y.T. Zhang, I. Mezic, C.D. Meinhart, and L. Petzold, “Numerical Simulation of an Electroosmotic Micromixer,” *Proc. Microfluidics 2003* (ASME IMECE), 2003.
2. Y.T. Zhang, H. Chen, I. Mezic, C.D. Meinhart, L. Petzold, and N.C. MacDonald, “SOI Processing of a Ring Electrokinetic Chaotic Micromixer,” *Proc. NSTI Nanotechnology Conference and Trade Show* (Nanotech 2004), vol. 1, pp. 292–295, 2004.
3. E. Cummings, S. Griffiths, R. Nilson, and P. Paul, “Conditions for Similitude Between the Fluid Velocity and the Electric Field in Electroosmotic Flow,” *Anal. Chem.*, vol. 72, pp. 2526–2532, 2000.

Application Library path: Microfluidics_Module/Micromixers/
electroosmotic_mixer

Modeling Instructions



From the **File** menu, choose **New**.

NEW

In the **New** window, click  **Model Wizard**.

MODEL WIZARD

I In the **Model Wizard** window, click  **2D**.

- 2 In the **Select Physics** tree, select **Chemical Species Transport > Reacting Flow > Laminar Flow, Diluted Species**.
- 3 Click **Add**.
- 4 In the **Select Physics** tree, select **AC/DC > Electric Fields and Currents > Electric Currents (ec)**.
- 5 Click **Add**.
- 6 Click  **Study**.
- 7 In the **Select Study** tree, select **General Studies > Stationary**.
- 8 Click  **Done**.

GLOBAL DEFINITIONS

Parameters 1

- 1 In the **Model Builder** window, under **Global Definitions** click **Parameters 1**.
- 2 In the **Settings** window for **Parameters**, locate the **Parameters** section.
- 3 In the table, enter the following settings:

Name	Expression	Value	Description
U0	0.1[mm/s]	1E-4 m/s	Mean inflow velocity
sigma_w	0.11845[S/m]	0.11845 S/m	Conductivity of the ionic solution
eps_r	80.2	80.2	Relative permittivity of the fluid
zeta	-0.1[V]	-0.1 V	Zeta potential
V0	0.1[V]	0.1 V	Maximum value of the AC potential
omega	2*pi[rad]*8[Hz]	50.265 Hz	Angular frequency of the AC potential
t	0[s]	0 s	Start time
D	1e-11[m^2/s]	1E-11 m ² /s	Diffusion coefficient of the solution
c0	1[mol/m^3]	1 mol/m ³	Initial concentration

You need the constant t (used in the scalar expressions below) when first solving the model using a stationary solver. In the time-dependent simulation, the internal time

variable, t , overwrites this constant (the red color is just a warning signaling that t is an internal variable).

Now define a smoothed step function that you will later use to impose a step in the concentration in the middle of the channel entrance.

Step 1 (step1)

- 1 In the **Home** toolbar, click  **Functions** and choose **Global > Step**.
- 2 In the **Settings** window for **Step**, click to expand the **Smoothing** section.
- 3 In the **Size of transition zone** text field, type $0.1e-6$.

GEOMETRY 1

- 1 In the **Model Builder** window, under **Component 1 (comp1)** click **Geometry 1**.
- 2 In the **Settings** window for **Geometry**, locate the **Units** section.
- 3 From the **Length unit** list, choose μm .

Rectangle 1 (r1)

- 1 In the **Geometry** toolbar, click  **Rectangle**.
- 2 In the **Settings** window for **Rectangle**, locate the **Position** section.
- 3 From the **Base** list, choose **Center**.
- 4 Locate the **Size and Shape** section. In the **Width** text field, type 80.
- 5 In the **Height** text field, type 10.

Circle 1 (c1)

- 1 In the **Geometry** toolbar, click  **Circle**.
- 2 In the **Settings** window for **Circle**, locate the **Size and Shape** section.
- 3 In the **Radius** text field, type 15.

To add vertices for the electrode endpoints on the outer boundary, use the Partition Edges.

Partition Edges 1 (pare1)

- 1 In the **Geometry** toolbar, click  **Booleans and Partitions** and choose **Partition Edges**.

2 On the object **c1**, select Boundaries 1–4 only.

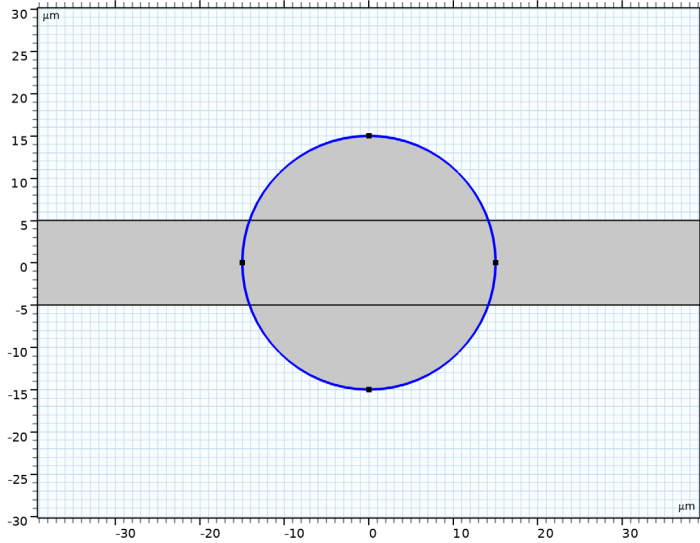

3 In the **Settings** window for **Partition Edges**, locate the **Positions** section.

4 In the table, enter the following settings:

Relative arc length parameters

0.47

0.53

Circle 2 (c2)

1 In the **Geometry** toolbar, click  **Circle**.

2 In the **Settings** window for **Circle**, locate the **Size and Shape** section.

3 In the **Radius** text field, type 5.

Compose 1 (c1)

1 In the **Geometry** toolbar, click  **Booleans and Partitions** and choose **Compose**.

2 Click in the **Graphics** window and then press Ctrl+A to select all objects.

3 In the **Settings** window for **Compose**, locate the **Compose** section.

4 In the **Set formula** text field, type $(r1+pare1) - c2$.

5 Clear the **Keep interior boundaries** checkbox.

Form Union (fin)

- 1 In the **Model Builder** window, click **Form Union (fin)**.

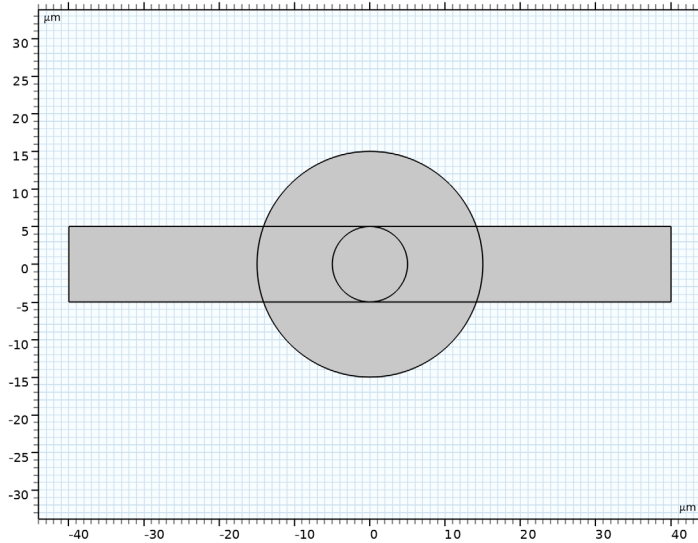

The model geometry is now complete.

MATERIALS

Material 1 (mat1)

- 1 In the **Model Builder** window, under **Component 1 (comp1)** right-click **Materials** and choose **Blank Material**.
- 2 In the **Settings** window for **Material**, locate the **Material Contents** section.
- 3 In the table, enter the following settings:

Property	Variable	Value	Unit	Property group
Density	rho	1e3 [kg/m ³]	kg/m ³	Basic
Dynamic viscosity	mu	1e-3 [Pa*s]	Pa*s	Basic

Property	Variable	Value	Unit	Property group
Electric conductivity	sigma_iso ; sigma _{ii} = sigma_iso, sigma _{ij} = 0	sigma_w	S/m	Basic
Relative permittivity	epsilon _{nr_} iso ; epsilon _{nr_{ii}} = epsilon _{nr_} iso, epsilon _{nr_{ij}} = 0	eps_r	1	Basic

LAMINAR FLOW (SPF)

1 In the **Model Builder** window, under **Component 1 (comp1)** click **Laminar Flow (spf)**.

2 In the **Settings** window for **Laminar Flow**, click to expand the **Discretization** section.

3 From the **Discretization of fluids** list, choose **P2+P1**.

Using higher-order elements can improve the accuracy of the solution significantly for low Reynolds number flows such as those in this model.

Inlet 1

1 In the **Physics** toolbar, click  **Boundaries** and choose **Inlet**.

2 Select Boundary 1 only.

3 In the **Settings** window for **Inlet**, locate the **Boundary Condition** section.

4 From the list, choose **Fully developed flow**.

5 Locate the **Fully Developed Flow** section. In the U_{av} text field, type $U0$.

Outlet 1

1 In the **Physics** toolbar, click  **Boundaries** and choose **Outlet**.

2 Select Boundary 6 only.

Wall 1

1 In the **Model Builder** window, click **Wall 1**.

2 In the **Settings** window for **Wall**, locate the **Boundary Condition** section.

3 From the **Wall condition** list, choose **Electroosmotic velocity**.

4 Specify the **E** vector as

ec.Ex*sin(omega*t)	x
ec.Ey*sin(omega*t)	y

- 5 From the **Electroosmotic mobility** list, choose **Built-in expression**.
- 6 In the ζ text field, type zeta.
- 7 In the ϵ_r text field, type eps_r.

TRANSPORT OF DILUTED SPECIES (TDS)

Raise the element order to match that of the **Laminar Flow** interface.

- 1 In the **Model Builder** window, under **Component 1 (comp1)** click **Transport of Diluted Species (tds)**.
- 2 In the **Settings** window for **Transport of Diluted Species**, click to expand the **Discretization** section.
- 3 From the **Concentration** list, choose **Quadratic**.

Fluid 1

- 1 In the **Model Builder** window, under **Component 1 (comp1)** > **Transport of Diluted Species (tds)** click **Fluid 1**.
- 2 In the **Settings** window for **Fluid**, locate the **Diffusion** section.
- 3 In the D_c text field, type D.

Note that the velocity field for the species convection is controlled by the **Reacting Flow**, **Diluted Species** multiphysics coupling.

Concentration 1

- 1 In the **Physics** toolbar, click  **Boundaries** and choose **Concentration**.
- 2 Select Boundary 1 only.
- 3 In the **Settings** window for **Concentration**, locate the **Concentration** section.
- 4 Select the **Species c** checkbox.
- 5 In the $c_{0,c}$ text field, type $c0*step1(y[1/m])$.

The concentration condition on boundaries 1 and 3 gives a sharp but smooth concentration gradient in the middle of the channel entrance.

Outflow 1

- 1 In the **Physics** toolbar, click  **Boundaries** and choose **Outflow**.
- 2 Select Boundary 6 only.

ELECTRIC CURRENTS (EC)

In the **Model Builder** window, under **Component 1 (comp1)** click **Electric Currents (ec)**.

Electric Potential 1

- 1 In the **Physics** toolbar, click  **Boundaries** and choose **Electric Potential**.
- 2 Select Boundaries 9 and 20 only.

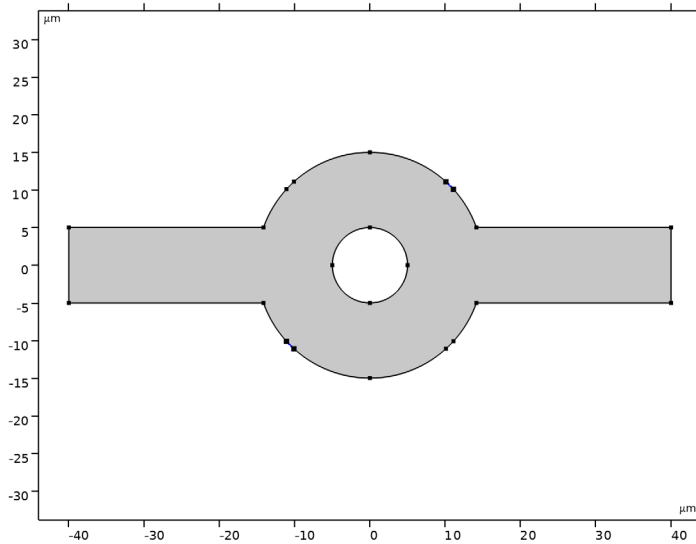

- 3 In the **Settings** window for **Electric Potential**, locate the **Electric Potential** section.
- 4 In the V_0 text field, type $-V_0$.

Electric Potential 2

- 1 In the **Physics** toolbar, click  **Boundaries** and choose **Electric Potential**.

2 Select Boundaries 10 and 19 only.

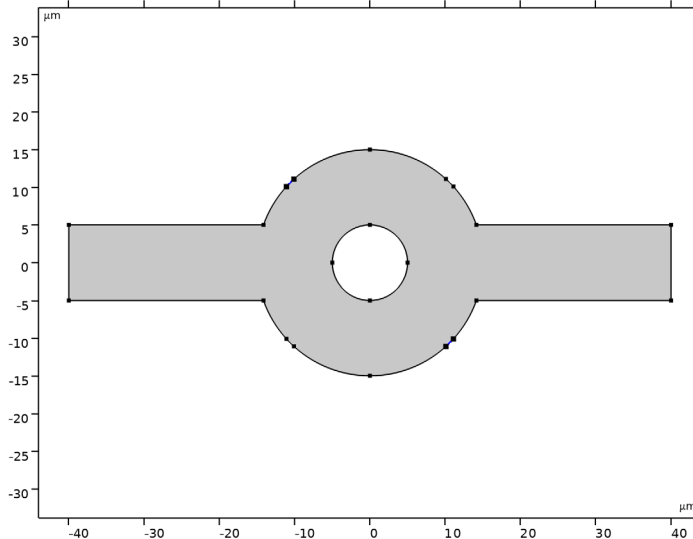

3 In the **Settings** window for **Electric Potential**, locate the **Electric Potential** section.

4 In the V_0 text field, type V_0 .

MESH 1

Free Triangular 1

In the **Mesh** toolbar, click  **Free Triangular**.

Size

1 In the **Model Builder** window, click **Size**.

2 In the **Settings** window for **Size**, locate the **Element Size** section.

3 From the **Predefined** list, choose **Extra fine**.

Size 1

1 In the **Model Builder** window, right-click **Free Triangular 1** and choose **Size**.

2 In the **Settings** window for **Size**, locate the **Geometric Entity Selection** section.

3 From the **Geometric entity level** list, choose **Boundary**.

4 Select Boundaries 9, 10, 19, and 20 only.

5 Locate the **Element Size** section. Click the **Custom** button.

6 Locate the **Element Size Parameters** section.

- 7 Select the **Maximum element size** checkbox. In the associated text field, type 0.2.
- 8 Select the **Maximum element growth rate** checkbox. In the associated text field, type 1.1.
- 9 Click  **Build All**.

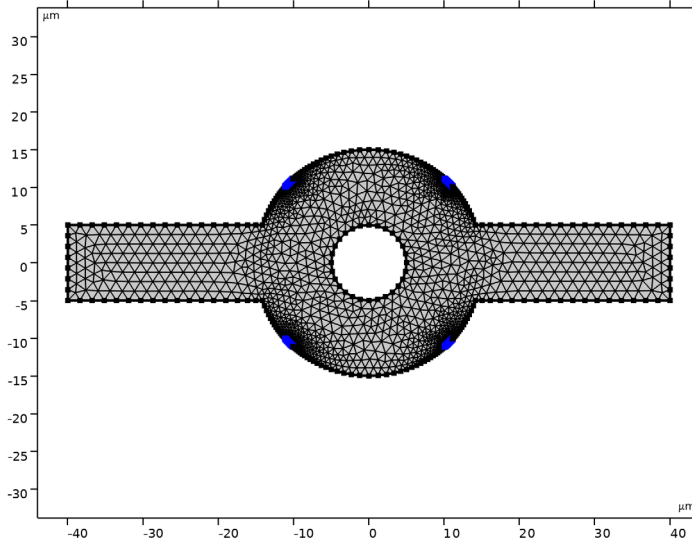

STUDY 1

Set up the study to start by computing the stationary solution for velocity, pressure, concentration, and electric potential. Then, add a transient simulation stage that solves only for the variables of the **Laminar Flow** and **Transport of Diluted Species** interfaces. Begin by adding a study step for the transient part.



Step 2: Time Dependent

- 1 In the **Study** toolbar, click  **Time Dependent**.
- 2 In the **Settings** window for **Time Dependent**, locate the **Study Settings** section.
- 3 In the **Output times** text field, type range(0,0.125/60,0.5).
- 4 Locate the **Physics and Variables Selection** section. In the **Solve for** column of the table, under **Component 1 (comp1)**, clear the checkbox for **Electric Currents (ec)**.
- 5 In the **Model Builder** window, click **Study 1**.
- 6 In the **Settings** window for **Study**, locate the **Study Settings** section.

7 Clear the **Generate default plots** checkbox.

This is convenient if you want to create specialized plots while keeping the number of plot groups down.

Solution 1 (sol1)

- 1 In the **Study** toolbar, click  **Show Default Solver**.
- 2 In the **Model Builder** window, expand the **Solution 1 (sol1)** node, then click **Time-Dependent Solver 1**.
- 3 In the **Settings** window for **Time-Dependent Solver**, click to expand the **Absolute Tolerance** section.
- 4 From the **Tolerance method** list, choose **Manual**.
- 5 In the **Absolute tolerance** text field, type $5.0E-5$.
- 6 In the **Study** toolbar, click  **Compute**.



RESULTS

The following instructions show how to reproduce the plots in the [Results and Discussion](#) section.

Velocity, streamlines

- 1 In the **Results** toolbar, click  **2D Plot Group**.
- 2 In the **Settings** window for **2D Plot Group**, type **Velocity, streamlines** in the **Label** text field.
- 3 Locate the **Data** section. From the **Time (s)** list, choose **0.0375**.

Streamline 1



- 1 Right-click **Velocity, streamlines** and choose **Streamline**.
- 2 In the **Settings** window for **Streamline**, click **Replace Expression** in the upper-right corner of the **Expression** section. From the menu, choose **Component 1 (comp1) > Laminar Flow > Velocity and pressure > u,v - Velocity field**.
- 3 Locate the **Streamline Positioning** section. From the **Positioning** list, choose **Uniform density**.
- 4 In the **Density level** text field, type 9.4 .
- 5 In the **Velocity, streamlines** toolbar, click  **Plot**.
- 6 Click the  **Zoom Extents** button in the **Graphics** toolbar.
- 7 Click the  **Zoom In** button in the **Graphics** toolbar.

Compare the result with [Figure 2](#).

Electric potential

- 1 In the **Results** toolbar, click  **2D Plot Group**.
- 2 In the **Settings** window for **2D Plot Group**, type **Electric potential** in the **Label** text field.
- 3 Locate the **Data** section. From the **Time (s)** list, choose **0.0375**.

Contour 1

- 1 Right-click **Electric potential** and choose **Contour**.
- 2 In the **Settings** window for **Contour**, click **Replace Expression** in the upper-right corner of the **Expression** section. From the menu, choose **Component 1 (comp1) > Electric Currents > Electric > V - Electric potential - V**.
- 3 In the **Electric potential** toolbar, click  **Plot**.
- 4 Click the  **Zoom Extents** button in the **Graphics** toolbar.
Compare the result with [Figure 3](#).

Concentration

- 1 In the **Results** toolbar, click  **2D Plot Group**.
- 2 In the **Settings** window for **2D Plot Group**, type **Concentration** in the **Label** text field.

Surface 1

- 1 Right-click **Concentration** and choose **Surface**.
- 2 In the **Settings** window for **Surface**, click **Replace Expression** in the upper-right corner of the **Expression** section. From the menu, choose **Component 1 (comp1) > Transport of Diluted Species > Species c > c - Molar concentration, c - mol/m³**.

Streamline 1

- 1 In the **Model Builder** window, right-click **Concentration** and choose **Streamline**.
- 2 In the **Settings** window for **Streamline**, click **Replace Expression** in the upper-right corner of the **Expression** section. From the menu, choose **Component 1 (comp1) > Laminar Flow > Velocity and pressure > u,v - Velocity field**.
- 3 Locate the **Streamline Positioning** section. From the **Positioning** list, choose **Uniform density**.
- 4 In the **Density level** text field, type **9.4**.

Concentration

- 1 In the **Model Builder** window, click **Concentration**.
- 2 In the **Settings** window for **2D Plot Group**, locate the **Data** section.
- 3 From the **Time (s)** list, choose **0**.

4 In the **Concentration** toolbar, click  **Plot**.

Compare the result with [Figure 4](#).

5 From the **Time (s)** list, choose **0.46875**.

6 In the **Concentration** toolbar, click  **Plot**.

Compare the result with [Figure 5](#).