



Model created in COMSOL Multiphysics 6.4

Controlled Diffusion Separator¹

1. This example was originally formulated by Albert Witarsa under Professor Bruce Finlayson's supervision at the University of Washington in Seattle. It was part of a graduate course in which the assignment consisted of using mathematical modeling to evaluate the potential of patents in the field of microfluidics.

Introduction

This model treats an H-shaped microfluidic device for controlled separation through diffusion. The device puts two different laminar streams in contact for a controlled period of time. The contact surface is well defined, and by controlling the flow rate it is possible to maintain the laminar flow field and control the amount of species transported from one stream to the other through diffusion. The device concept is illustrated in [Figure 1](#). The design aims to maintain a laminar flow field when the two streams, A and B, are united and thus prevent uncontrolled convective mixing. The transport of species between streams A and B should take place only by diffusion in order that species with low diffusion coefficients stay in their respective streams. In this way, light species with high diffusivity can be separated from heavy species with low diffusivity. Let us look at a mixture of light and heavy species entering through inlet A. If the separator is properly designed, the heavy species should exit almost exclusively through outlet A. The lighter species should exit through both outlet A and B in equal rates. In this way, outlet B contains only the lighter species.

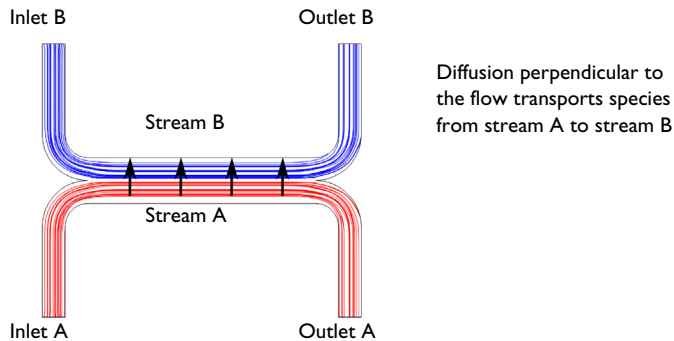

Figure 1: Diagram of the device.

Model Definition

The geometry of the device is shown in [Figure 2](#). The device geometry is split in two because of symmetry.

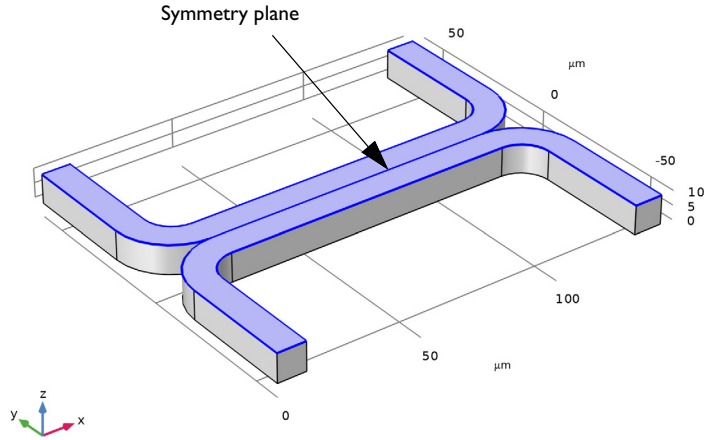

Figure 2: Model geometry. To avoid any type of convective mixing, the design must smoothly let both streams come in contact with each other. Due to symmetry, it is sufficient to model half the geometry, so the actual channel is twice as high in the z direction.

The flow rate at the inlet is approximately 0.1 mm/s. The Reynolds number, which is important for characterizing the flow is given by:

$$\text{Re} = \frac{\rho UL}{\mu} = 0,001$$

where ρ is the fluid density (1000 kg/m³), U is a characteristic velocity of the flow (0.1 mm/s), μ is the fluid viscosity (1 mPa·s) and L is a characteristic dimension of the device (10 μm). When the Reynolds number is significantly less than 1, as in this example, the Creeping Flow interface can be used. The convective term in the Navier–Stokes equations can be dropped, leaving the incompressible Stokes equations:

$$\begin{aligned} \nabla \cdot (-p\mathbf{I} + \mu(\nabla\mathbf{u} + (\nabla\mathbf{u})^T)) &= 0 \\ \nabla \cdot \mathbf{u} &= 0 \end{aligned}$$

where \mathbf{u} is the local velocity (m/s) and p is the pressure (Pa).

Mixing in the device involves species at relatively low concentrations compared to the solvent, in this case water. This means that the solute molecules interact only with water

molecules, and Fick's law can be used to describe the diffusive transport. The mass-balance equation for the solute is therefore

$$-\nabla \cdot (-D\nabla c + c\mathbf{u}) = 0 \quad (1)$$

where D is the diffusion coefficient of the solute (m^2/s) and c is its concentration (mol/m^3). Diffusive flows can be characterized by another dimensionless number: the Peclet number, which is given by

$$\text{Pe} = \frac{LU}{D}$$

In this model, the parametric solver is used to solve [Equation 1](#) for three different species, each with different values of D : $1 \times 10^{-11} \text{ m}^2/\text{s}$, $5 \times 10^{-11} \text{ m}^2/\text{s}$, and $1 \times 10^{-10} \text{ m}^2/\text{s}$. These values of D correspond to Peclet numbers of 100, 20, and 10 respectively. Since these Peclet numbers are all greater than 1, implying a cell Peclet number significantly greater than 1, numerical stabilization is required when solving Fick's equation. COMSOL automatically includes the stabilization by default, so no explicit settings are required.

Two versions of the model are solved:

- In the first version, it is assumed that a change in solute concentration does not influence the fluid's density and viscosity. This implies that it is possible to first solve the Navier–Stokes equations and then solve the mass balance equation.
- In the second version, the viscosity depends quadratically on the concentration:

$$\mu = \mu_0(1 + \alpha c^2)$$

Here α is a constant of dimension $\text{m}^6/(\text{mol})^2$ and μ_0 is the viscosity at zero concentration. Such a relationship between concentration and viscosity is usually observed in solutions of larger molecules.

Results and Discussion

Figure 3 shows the velocity field for the case where viscosity is concentration independent. The flow is symmetric and is not influenced by the concentration field. Figure 4 shows the corresponding pressure distribution on the channel walls that results from the flow.

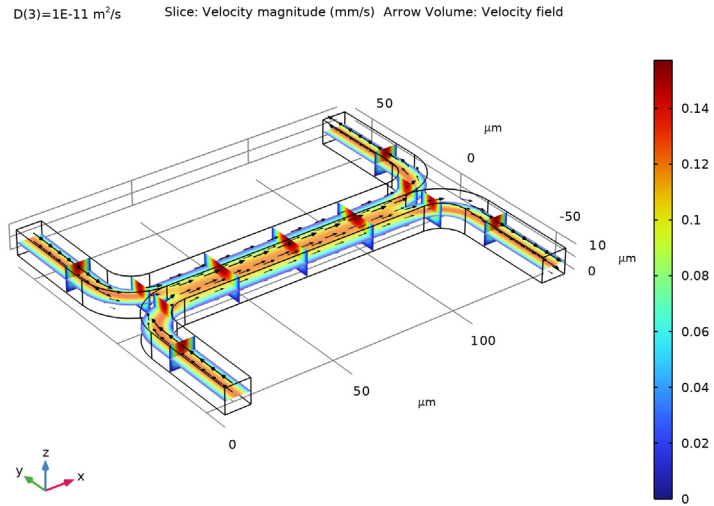

Figure 3: Flow velocity field.

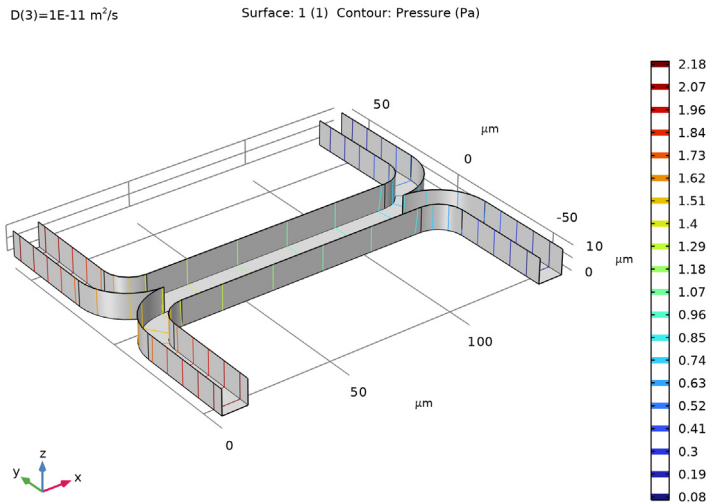

Figure 4: Pressure distribution on the channel walls.

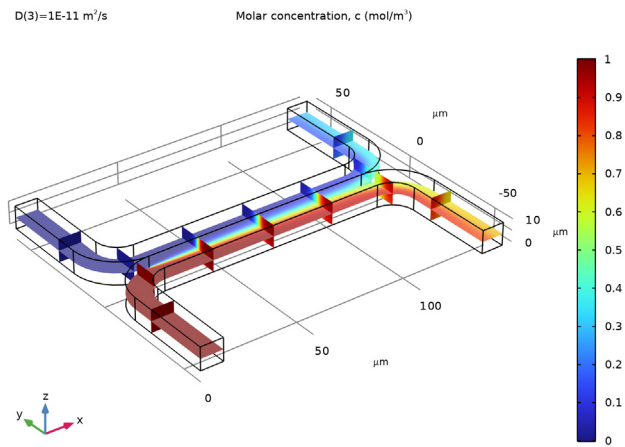

Figure 5: Concentration distribution for a species with diffusivity $1 \cdot 10^{-11} \text{ m}^2/\text{s}$.

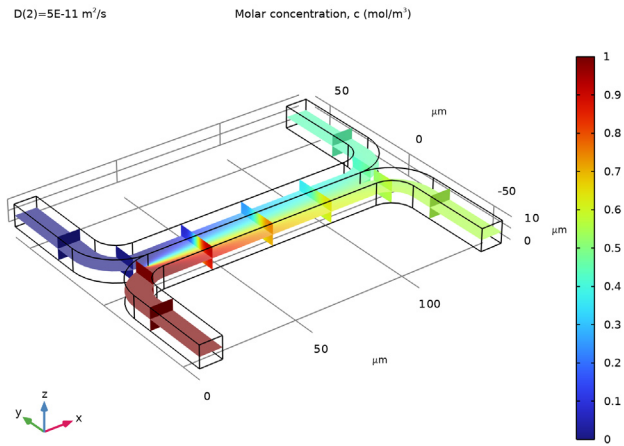

Figure 6: Concentration distribution for a species with diffusivity $5 \cdot 10^{-11} \text{ m}^2/\text{s}$.

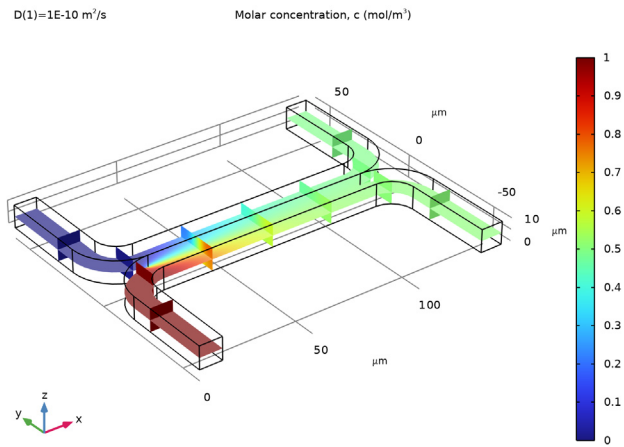

Figure 7: Concentration distribution for a species with diffusivity $1 \cdot 10^{-10} \text{ m}^2/\text{s}$.

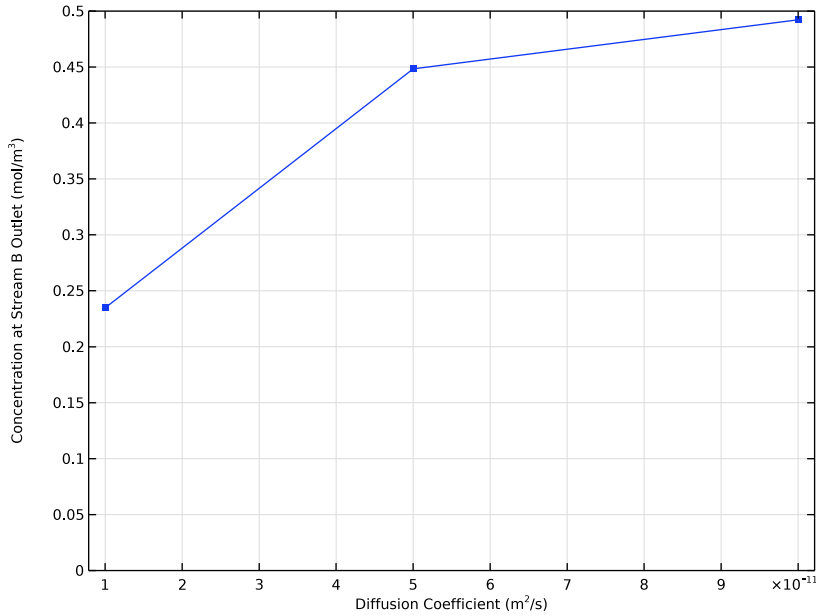

Figure 8: Average concentration at the outlet of stream B as a function of the diffusion coefficient.

Figure 5, Figure 6, and Figure 7 show the species concentration for the each of the three diffusion coefficients. For the heaviest species, which has the smallest diffusivity, there is almost no significant mixing between streams A and B (Figure 5). For the lightest species, which has the largest diffusion coefficient, the mixing is almost perfect (Figure 7).

Figure 8 shows how the mean concentration of the species at the outlet of stream B varies for the different species diffusion coefficients. The simulation clearly shows that the device could be used to separate lighter molecules from heavier ones. By placing a number of these devices in series, a high degree of separation could be obtained.

In some cases, especially those involving solutions of macromolecules, the macromolecule concentration has a large influence on the liquid’s viscosity. In such situations, the Navier–Stokes and the convection–diffusion equations become coupled, and so they must be solved simultaneously. Figure 9, Figure 10, and Figure 11 show the results of such a simulation, in which the Navier–Stokes equations are solved with a concentration-dependent viscosity. In this case, for the species with diffusivity $5 \cdot 10^{-11} \text{ m}^2/\text{s}$. The velocity field is altered slightly by the concentration dependent viscosity (see Figure 12) but this has little effect on the mean stream A outlet concentration, which changes only

slightly from 0.448 to 0.45. Much more serious is the effect of the nonuniform viscosity on the pressure distribution required to maintain the two streams at the same flow rate. A larger pressure is required at the inlet of stream B to drive the higher viscosity fluid through the system. This asymmetry in the pressure distribution makes placing several devices in series much more difficult.

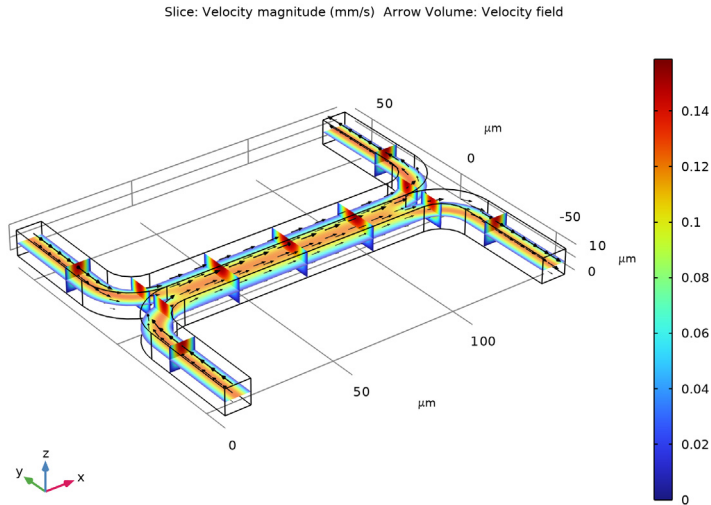

Figure 9: Velocity field. The viscosity varies with the concentration according to $\mu = \mu_0(1 + \alpha c^2)$ with $\alpha = 0.5 \text{ (m}^3/\text{mol)}^2$. It is difficult to see the differences between this figure and that in Figure 3, but careful inspection reveals a slight change in the velocity profile. This is highlighted further in Figure 12.

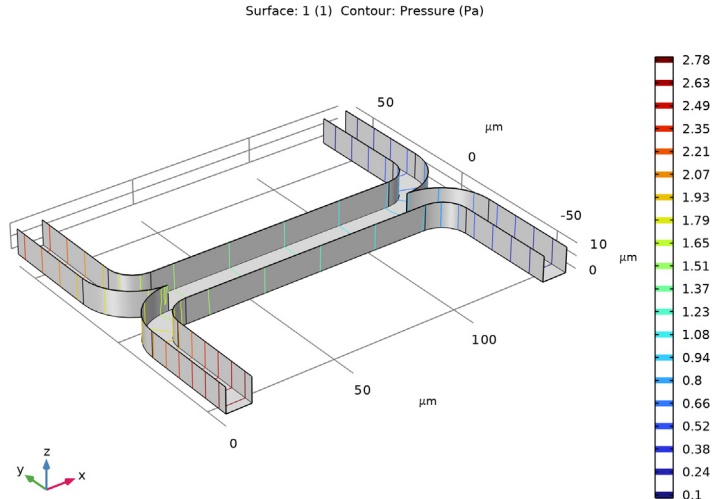

Figure 10: Pressure distribution. The viscosity varies with the concentration according to $\mu = \mu_0(1 + \alpha c^2)$ with $\alpha = 0.5 \text{ (m}^3/\text{mol)}^2$. This figure should be compared to Figure 4. There are significant differences between the two cases.

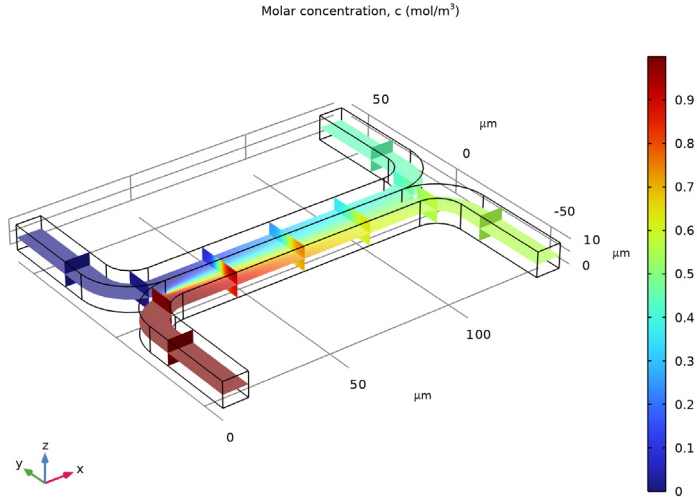

Figure 11: Concentration distribution for the species with diffusivity $5 \cdot 10^{-11} \text{ m}^2/\text{s}$ for the case where the fluid viscosity varies with concentration. This plot is very similar to the corresponding plot for an uncoupled flow, shown in Figure 6.

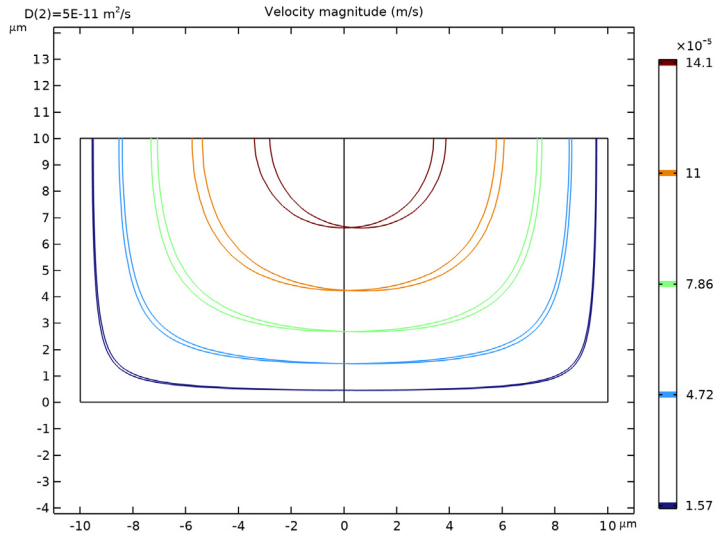



Figure 12: Comparison of the velocity field for the uncoupled and coupled flow simulations showing the difference between the two cases. The coupled flow, in which the fluid viscosity is a function of concentration, is asymmetric.

Application Library path: Microfluidics_Module/Micromixers/
controlled_diffusion_separator



Modeling Instructions

From the **File** menu, choose **New**.

NEW

In the **New** window, click  **Model Wizard**.

MODEL WIZARD

- 1 In the **Model Wizard** window, click  **3D**.
- 2 In the **Select Physics** tree, select **Fluid Flow** > **Single-Phase Flow** > **Creeping Flow (spf)**.
- 3 Click **Add**.
- 4 In the **Select Physics** tree, select **Chemical Species Transport** > **Transport of Diluted Species (tds)**.
- 5 Click **Add**.
- 6 Click  **Study**.
- 7 In the **Select Study** tree, select **General Studies** > **Stationary**.
- 8 Click  **Done**.

GEOMETRY I

For many microfluidic devices it is convenient to specify the geometry dimensions using micrometers.

- 1 In the **Model Builder** window, under **Component 1 (comp1)** click **Geometry 1**.
- 2 In the **Settings** window for **Geometry**, locate the **Units** section.
- 3 From the **Length unit** list, choose **µm**.

The geometry can be constructed by extruding a 2-dimensional work plane. First draw a top down view of the structure in the work plane.



Work Plane 1 (wp1)

- 1 In the **Geometry** toolbar, click  **Work Plane**.
- 2 In the **Settings** window for **Work Plane**, click  **Go to Plane Geometry**.



Work Plane 1 (wp1) > Plane Geometry

In the **Model Builder** window, click **Plane Geometry**.



Work Plane 1 (wp1) > Rectangle 1 (r1)

- 1 In the **Work Plane** toolbar, click  **Rectangle**.
- 2 In the **Settings** window for **Rectangle**, locate the **Size and Shape** section.
- 3 In the **Width** text field, type 140.
- 4 In the **Height** text field, type 60.
- 5 Click  **Build Selected**.

Work Plane 1 (wp1) > Rectangle 2 (r2)

- 1 In the **Work Plane** toolbar, click  **Rectangle**.
- 2 In the **Settings** window for **Rectangle**, locate the **Size and Shape** section.
- 3 In the **Width** text field, type 120.
- 4 In the **Height** text field, type 50.
- 5 Locate the **Position** section. In the **xw** text field, type 10.
- 6 In the **yw** text field, type 10.
- 7 Click  **Build Selected**.

Work Plane 1 (wp1) > Difference 1 (dif1)

- 1 In the **Work Plane** toolbar, click  **Booleans and Partitions** and choose **Difference**.
- 2 Select the object **r1** only.
- 3 In the **Settings** window for **Difference**, locate the **Difference** section.
- 4 Click to select the  **Activate Selection** toggle button for **Objects to subtract**.
- 5 Select the object **r2** only.
- 6 Click  **Build Selected**.



Work Plane 1 (wp1) > Fillet 1 (fil1)

- 1 In the **Work Plane** toolbar, click  **Fillet**.
- 2 On the object **dif1**, select Points 3 and 5 only.



It might be easier to select the correct points by using the **Selection List** window. To open this window, in the **Home** toolbar click **Windows** and choose **Selection List**. (If you are running the cross-platform desktop, you find **Windows** in the main menu.)

- 3 In the **Settings** window for **Fillet**, locate the **Radius** section.
- 4 In the **Radius** text field, type 10.
- 5 Click  **Build Selected**.



Work Plane 1 (wp1) > Fillet 2 (fil2)

- 1 In the **Work Plane** toolbar, click  **Fillet**.
- 2 On the object **fil1**, select Points 1 and 9 only.
- 3 In the **Settings** window for **Fillet**, locate the **Radius** section.
- 4 In the **Radius** text field, type 20.
- 5 Click  **Build Selected**.

Work Plane 1 (wp1) > Mirror 1 (mir1)

- 1 In the **Work Plane** toolbar, click  **Transforms** and choose **Mirror**.
- 2 Select the object **fil2** only.
- 3 In the **Settings** window for **Mirror**, locate the **Input** section.
- 4 Select the **Keep input objects** checkbox.
- 5 Locate the **Normal Vector to Line of Reflection** section. In the **xw** text field, type 0.
- 6 In the **yw** text field, type 1.
- 7 Click  **Build Selected**.

Work Plane 1 (wp1) > Union 1 (uni1)

- 1 In the **Work Plane** toolbar, click  **Booleans and Partitions** and choose **Union**.
- 2 Click in the **Graphics** window and then press Ctrl+A to select both objects.
- 3 In the **Settings** window for **Union**, click  **Build Selected**.

Extrude the 2D geometry to create a 3 dimensional geometry.

Extrude 1 (ext1)

- 1 In the **Model Builder** window, under **Component 1 (comp1) > Geometry 1** right-click **Work Plane 1 (wp1)** and choose **Extrude**.
- 2 In the **Settings** window for **Extrude**, locate the **Distances** section.
- 3 In the table, enter the following settings:

Distances (µm)
10

- 4 Click  **Build Selected**.

5 Click the  **Zoom Extents** button in the **Graphics** toolbar.

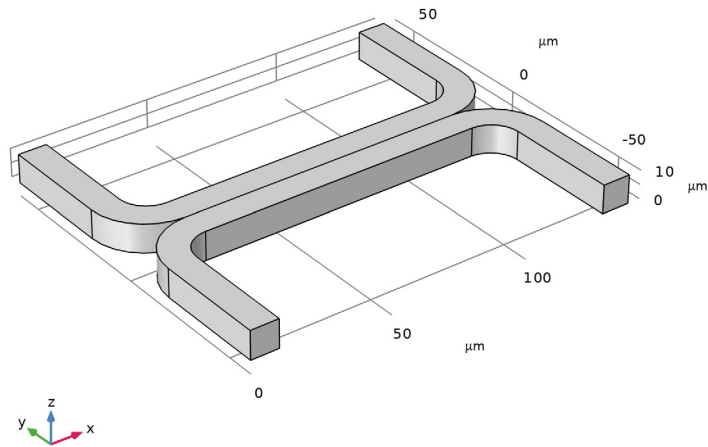

Create parameters to define the model.

GLOBAL DEFINITIONS

Parameters 1

- 1 In the **Model Builder** window, under **Global Definitions** click **Parameters 1**.
- 2 In the **Settings** window for **Parameters**, locate the **Parameters** section.
- 3 In the table, enter the following settings:

Name	Expression	Value	Description
D	$5e-11 [m^2/s]$	$5E-11 m^2/s$	Diffusion constant
fr	$15 [pl/s]$	$1.5E-14 m^3/s$	Inlet flow rate
c0	$1 [mol/m^3]$	$1 mol/m^3$	Inlet concentration
alpha	$0.5 [(m^3/mol)^2]$	$0.5 m^6/mol^2$	Viscosity c^2 -term prefactor

MATERIALS

Material 1 (mat1)

- 1 In the **Model Builder** window, under **Component 1 (comp1)** right-click **Materials** and choose **Blank Material**.
- 2 In the **Settings** window for **Material**, locate the **Material Contents** section.
- 3 In the table, enter the following settings:

Property	Variable	Value	Unit	Property group
Density	rho	1000	kg/m ³	Basic
Dynamic viscosity	mu	1e-3	Pa·s	Basic

Use the **Reacting Flow**, **Diluted Species** multiphysics couplings to couple the velocity.

MULTIPHYSICS

Reacting Flow, Diluted Species 1 (rfd1)

In the **Physics** toolbar, click  **Multiphysics Couplings** and choose **Domain > Reacting Flow, Diluted Species**.

CREEPING FLOW (SPF)

Add a **Fully developed flow** inlet boundary condition.

Inlet 1

- 1 In the **Physics** toolbar, click  **Boundaries** and choose **Inlet**.
- 2 Select Boundaries 2 and 10 only.
- 3 In the **Settings** window for **Inlet**, locate the **Boundary Condition** section.
- 4 From the list, choose **Fully developed flow**.
- 5 Locate the **Fully Developed Flow** section. Click the **Flow rate** button.
- 6 In the V_0 text field, type $fr/2$.
Set the flow rate to one half of the parameter value, since only half of the geometry is modeled.

Add an outlet with a **Pressure** boundary condition.

Outlet 1

- 1 In the **Physics** toolbar, click  **Boundaries** and choose **Outlet**.
- 2 Select Boundaries 23 and 25 only.
The default pressure of 0 Pa is appropriate in this case.

Add a **Symmetry** boundary condition in the symmetry plane.

Symmetry 1

- 1 In the **Physics** toolbar, click  **Boundaries** and choose **Symmetry**.
- 2 Select Boundaries 4 and 9 only.

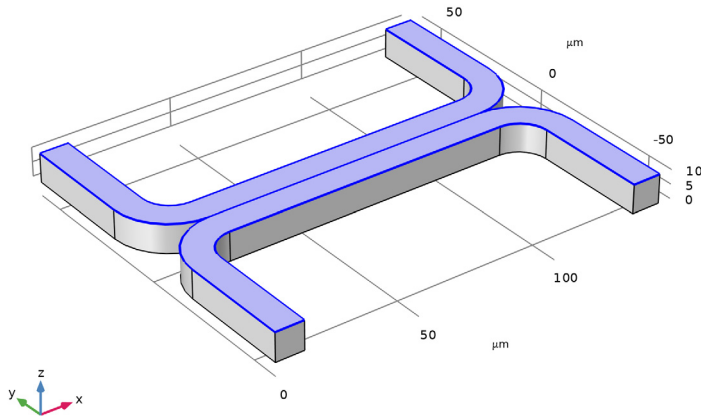

Now set up the mass transport physics. Start by raising the element order to quadratic, in order to match the discretization for the velocity.

TRANSPORT OF DILUTED SPECIES (TDS)

- 1 In the **Model Builder** window, under **Component 1 (comp1)** click **Transport of Diluted Species (tds)**.
- 2 In the **Settings** window for **Transport of Diluted Species**, click to expand the **Discretization** section.
- 3 From the **Concentration** list, choose **Quadratic**.

Fluid 1

The diffusion coefficient is set to use the parameter previously defined.

- 1 In the **Model Builder** window, under **Component 1 (comp1)** > **Transport of Diluted Species (tds)** click **Fluid 1**.
- 2 In the **Settings** window for **Fluid**, locate the **Diffusion** section.

3 In the D_c text field, type D.

Note that the velocity field for the species convection is controlled by the **Reacting Flow, Diluted Species** multiphysics coupling.

Specify the concentration at the two inlets.

Concentration 1

- 1 In the **Physics** toolbar, click  **Boundaries** and choose **Concentration**.
- 2 Select Boundary 2 only.
- 3 In the **Settings** window for **Concentration**, locate the **Concentration** section.
- 4 Select the **Species c** checkbox.
- 5 In the $c_{0,c}$ text field, type c0.



Concentration 2

- 1 In the **Physics** toolbar, click  **Boundaries** and choose **Concentration**.
- 2 Select Boundary 10 only.
- 3 In the **Settings** window for **Concentration**, locate the **Concentration** section.
- 4 Select the **Species c** checkbox.



In this case the concentration should take the default value of 0.

Use the **Outflow** condition to allow species to leave the domain by convection. Since we will ultimately be interested in the weighted average concentration, add two **Outflow** features, each of which will provide its own value.

Outflow 1

- 1 In the **Physics** toolbar, click  **Boundaries** and choose **Outflow**.
- 2 In the **Settings** window for **Outflow**, locate the **Boundary Selection** section.
- 3 Click  **Paste Selection**.
- 4 In the **Paste Selection** dialog, type 23 in the **Selection** text field.
- 5 Click **OK**.

Outflow 2

- 1 In the **Physics** toolbar, click  **Boundaries** and choose **Outflow**.
- 2 In the **Settings** window for **Outflow**, locate the **Boundary Selection** section.
- 3 Click  **Paste Selection**.
- 4 In the **Paste Selection** dialog, type 25 in the **Selection** text field.
- 5 Click **OK**.

Set up the mesh. By default, COMSOL will create a mesh for the physics currently in the model. Often this is good enough, but in this case, we want to make some small edits to the default mesh sequence.

MESH 1

By default, the fine mesh is not applied to interior boundaries. Typically this is wanted, since interior boundaries are transparent to the fluid flow. However, in this case, the mixing of the two streams occurs close to this interior boundary, so we can add boundary 16 to the **Size 1** and also the **Boundary Layer Properties 1** mesh feature.

- 1 In the **Model Builder** window, under **Component 1 (comp1)** click **Mesh 1**.
- 2 In the **Settings** window for **Mesh**, locate the **Physics-Controlled Mesh** section.
- 3 From the **Element size** list, choose **Coarse**.
- 4 Right-click **Component 1 (comp1)** > **Mesh 1** and choose **Edit Physics-Induced Sequence**.

Size 2

- 1 In the **Model Builder** window, under **Component 1 (comp1)** > **Mesh 1** click **Size 2**.
- 2 In the **Settings** window for **Size**, locate the **Geometric Entity Selection** section.
- 3 Click  **Paste Selection**.
- 4 In the **Paste Selection** dialog, type 16 in the **Selection** text field.
- 5 Click **OK**.

Boundary Layer Properties 1

- 1 In the **Model Builder** window, expand the **Component 1 (comp1)** > **Mesh 1** > **Boundary Layers 1** node, then click **Boundary Layer Properties 1**.
- 2 In the **Settings** window for **Boundary Layer Properties**, locate the **Boundary Selection** section.
- 3 Click  **Paste Selection**.
- 4 In the **Paste Selection** dialog, type 16 in the **Selection** text field.
- 5 Click **OK**.

6 In the **Settings** window for **Boundary Layer Properties**, click  **Build All**.

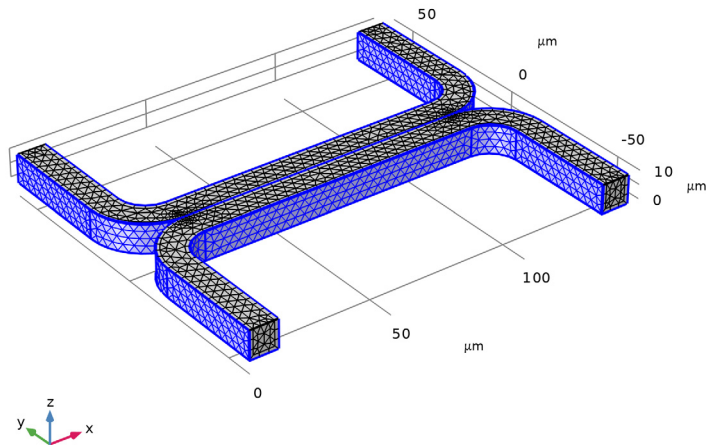

STUDY 1

Now set up a study to solve the problem. Initially it is assumed that the fluid flow and diffusion problems are uncoupled. In this case it makes sense to solve the fluid flow problem first and then to use the velocity field as an input for the diffusion problem. This will save time and memory, particularly since the diffusion problem is solved for three parameters.

Since the study will automatically generate a large number of default plots, default plots are disabled.

- 1 In the **Model Builder** window, click **Study 1**.
- 2 In the **Settings** window for **Study**, locate the **Study Settings** section.
- 3 Clear the **Generate default plots** checkbox.

For **Step 1**, solve only the creeping flow problem.

Step 1: Stationary

- 1 In the **Model Builder** window, under **Study 1** click **Step 1: Stationary**.
- 2 In the **Settings** window for **Stationary**, locate the **Physics and Variables Selection** section.

- 3 In the **Solve for** column of the table, under **Component 1 (comp1)**, clear the checkbox for **Transport of Diluted Species (tds)**.

Add a second study step.

Step 2: Stationary 2

- 1 In the **Study** toolbar, click  **Stationary**.

Disable the solution of the creeping flow problem for this step.

- 2 In the **Settings** window for **Stationary**, locate the **Physics and Variables Selection** section.
- 3 In the **Solve for** column of the table, under **Component 1 (comp1)**, clear the checkbox for **Creeping Flow (spf)**.

Solve the diffusion problem for three values of the diffusion coefficient.

- 4 Click to expand the **Study Extensions** section. Select the **Auxiliary sweep** checkbox.
- 5 Click  **Add**.
- 6 In the table, enter the following settings:

Parameter name	Parameter value list	Parameter unit
D (Diffusion constant)	1e-10 5e-11 1e-11	m ² /s

- 7 In the **Study** toolbar, click  **Compute**.

Create a **Surface** dataset to view the pressure on the channel walls.

RESULTS

Surface 1

- 1 In the **Model Builder** window, expand the **Results** node.
- 2 Right-click **Results** > **Datasets** and choose **Surface**.
- 3 In the **Settings** window for **Surface**, locate the **Selection** section.
- 4 Click  **Paste Selection**.
- 5 In the **Paste Selection** dialog, type 1 3 5 6 7 8 11 12 13 14 15 17 18 19 20 21 22 24 26 27 in the **Selection** text field.
- 6 Click **OK**.

Velocity (Uncoupled Flow)

- 1 In the **Results** toolbar, click  **3D Plot Group**.
- 2 In the **Settings** window for **3D Plot Group**, type Velocity (Uncoupled Flow) in the **Label** text field.

Use a **Slice** plot to view the data on one or more slices through the geometry.

Slice 1

- 1 Right-click **Velocity (Uncoupled Flow)** and choose **Slice**.
- 2 In the **Settings** window for **Slice**, locate the **Expression** section.
- 3 From the **Unit** list, choose **mm/s**.

Velocity (Uncoupled Flow)

Add additional slices in different directions.

Slice 2

- 1 In the **Model Builder** window, right-click **Velocity (Uncoupled Flow)** and choose **Slice**.
- 2 In the **Settings** window for **Slice**, locate the **Expression** section.
- 3 From the **Unit** list, choose **mm/s**.
- 4 Locate the **Plane Data** section. From the **Plane** list, choose **xy-planes**.
- 5 In the **Planes** text field, type 1.

The extra slices should use the same scale and colors for the velocity plot as the existing slice.

- 6 Click to expand the **Inherit Style** section. From the **Plot** list, choose **Slice 1**.
To avoid duplicate titles, turn off the title for additional slices.
- 7 Click to expand the **Title** section. From the **Title type** list, choose **None**.

Add slices in a third plane.

Slice 3

- 1 Right-click **Slice 2** and choose **Duplicate**.
- 2 In the **Settings** window for **Slice**, locate the **Plane Data** section.
- 3 From the **Plane** list, choose **zx-planes**.
- 4 In the **Planes** text field, type 2.

Use the **Arrow Volume** plot to visualize the flow direction.

Arrow Volume 1

- 1 In the **Model Builder** window, right-click **Velocity (Uncoupled Flow)** and choose **Arrow Volume**.
- 2 In the **Settings** window for **Arrow Volume**, locate the **Arrow Positioning** section.
- 3 Find the **x grid points** subsection. In the **Points** text field, type 14.
- 4 Find the **y grid points** subsection. In the **Points** text field, type 21.

- 5 Find the **z grid points** subsection. In the **Points** text field, type 3.
- 6 Locate the **Coloring and Style** section. From the **Color** list, choose **Black**.
- 7 In the **Velocity (Uncoupled Flow)** toolbar, click  **Plot**.

D(3)=1E-11 m²/s

Slice: Velocity magnitude (mm/s) Arrow Volume: Velocity field

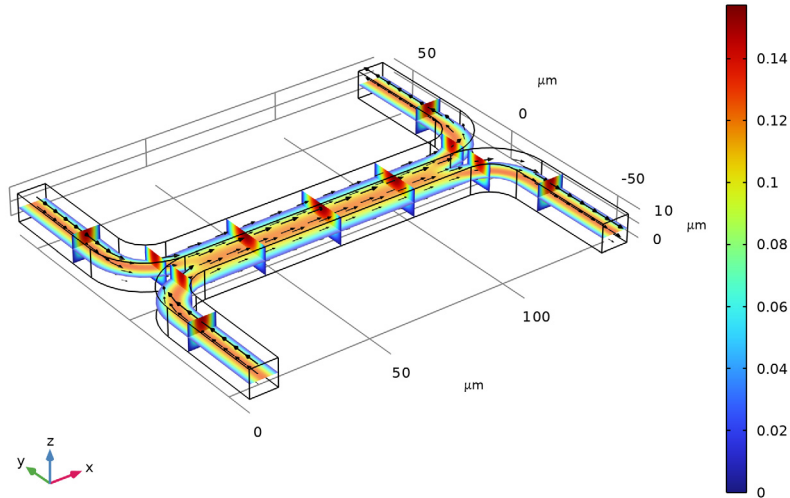

Next add a pressure plot, using the dataset created previously.

Pressure (Uncoupled Flow)

- 1 In the **Results** toolbar, click  **3D Plot Group**.
- 2 In the **Settings** window for **3D Plot Group**, type Pressure (Uncoupled Flow) in the **Label** text field.
- 3 Locate the **Data** section. From the **Dataset** list, choose **Surface 1**.

First add a uniformly colored surface, to highlight the channel walls.

Surface 1

- 1 Right-click **Pressure (Uncoupled Flow)** and choose **Surface**.
- 2 In the **Settings** window for **Surface**, locate the **Expression** section.
- 3 In the **Expression** text field, type 1.
- 4 Locate the **Coloring and Style** section. From the **Coloring** list, choose **Uniform**.
- 5 From the **Color** list, choose **Gray**.

Next use contours to visualize the pressure.

Contour 1

- 1 In the **Model Builder** window, right-click **Pressure (Uncoupled Flow)** and choose **Contour**.
- 2 In the **Settings** window for **Contour**, click **Replace Expression** in the upper-right corner of the **Expression** section. From the menu, choose **Component 1 (comp1) > Creeping Flow > Velocity and pressure > p - Pressure - Pa**.
- 3 In the **Pressure (Uncoupled Flow)** toolbar, click  **Plot**.

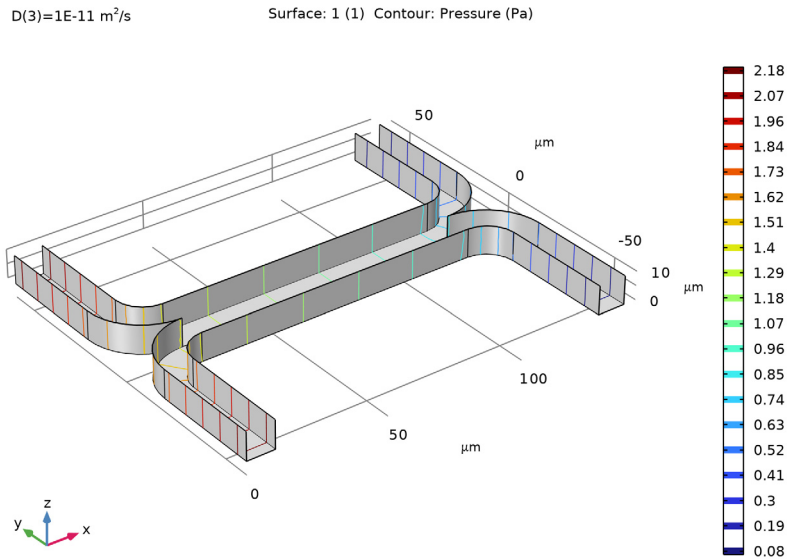

Next create a **Slice** plot to visualize the concentration in the device. Use the existing velocity slice plot as a basis for this plot.

Concentration (Uncoupled Flow)

- 1 In the **Model Builder** window, right-click **Velocity (Uncoupled Flow)** and choose **Duplicate**.
- 2 In the **Settings** window for **3D Plot Group**, type Concentration (Uncoupled Flow) in the **Label** text field.

For each of the slice subnodes, change the plotted quantity to concentration.

Slice 1

- 1 In the **Model Builder** window, expand the **Concentration (Uncoupled Flow)** node, then click **Slice 1**.

- 2 In the **Settings** window for **Slice**, click **Replace Expression** in the upper-right corner of the **Expression** section. From the menu, choose **Component 1 (comp1) > Transport of Diluted Species > Species c > c - Molar concentration, c - mol/m³**.

Slice 2

- 1 In the **Model Builder** window, click **Slice 2**.
- 2 In the **Settings** window for **Slice**, click **Replace Expression** in the upper-right corner of the **Expression** section. From the menu, choose **c - Molar concentration, c - mol/m³**.

Slice 3

- 1 In the **Model Builder** window, click **Slice 3**.
- 2 In the **Settings** window for **Slice**, click **Replace Expression** in the upper-right corner of the **Expression** section. From the menu, choose **c - Molar concentration, c - mol/m³**.

Disable the **Arrow Volume** plot.

Arrow Volume 1

In the **Model Builder** window, right-click **Arrow Volume 1** and choose **Disable**.

Concentration (Uncoupled Flow)

Look at the plot for each of the three diffusion coefficient levels.

The plots on the next page show the results for each of the diffusion coefficients solved for. For the heaviest species, which has the smallest diffusivity, there is limited mixing between streams A and B. For the lightest species, which has the largest diffusion coefficient, the mixing is almost perfect.

- 1 In the **Model Builder** window, click **Concentration (Uncoupled Flow)**.

2 In the **Concentration (Uncoupled Flow)** toolbar, click  **Plot**.

$D(3)=1E-11 \text{ m}^2/\text{s}$

Molar concentration, $c \text{ (mol/m}^3\text{)}$

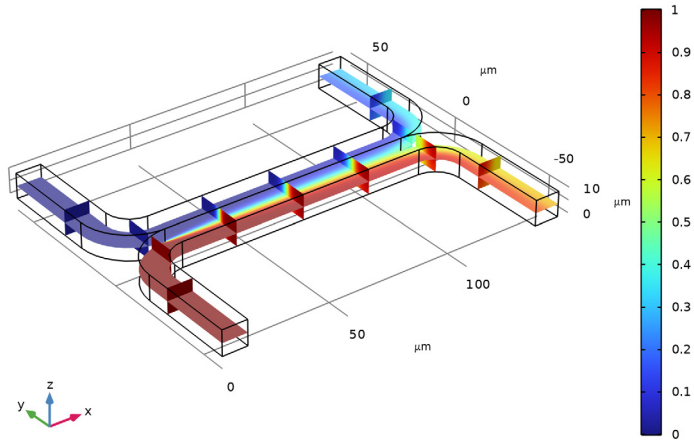

3 In the **Settings** window for **3D Plot Group**, click  **Plot Previous**.

$D(2)=5E-11 \text{ m}^2/\text{s}$

Molar concentration, $c \text{ (mol/m}^3\text{)}$

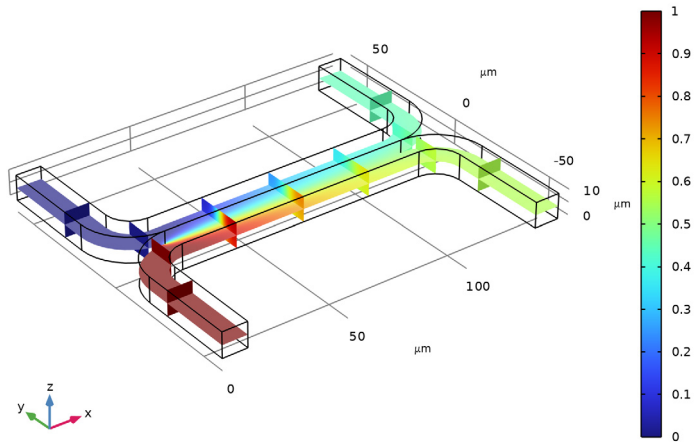

4 Click  **Plot Previous.**

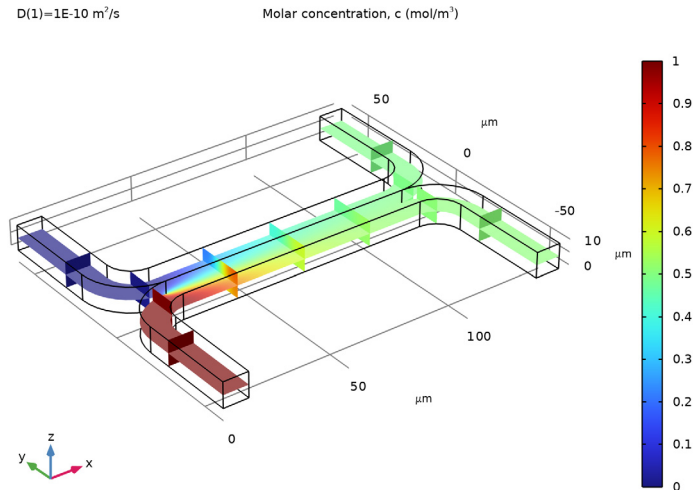

Add a **Global** plot to show how the concentration at the output differs with diffusion coefficient.

Output Concentration (Uncoupled Flow)

- 1 In the **Results** toolbar, click  **ID Plot Group**.
- 2 In the **Settings** window for **ID Plot Group**, type **Output Concentration (Uncoupled Flow)** in the **Label** text field.

Global 1

- 1 Right-click **Output Concentration (Uncoupled Flow)** and choose **Global**.
Use the built in variable to compute the average concentration at the device output.
- 2 In the **Settings** window for **Global**, click **Replace Expression** in the upper-right corner of the **y-Axis Data** section. From the menu, choose **Component 1 (comp1) > Transport of Diluted Species > Outflow 2 > tds.out2.c0_avg_c - Average concentration - mol/m³**.
No legend is necessary for this plot, as only one quantity is plotted.
- 3 Click to expand the **Legends** section. Clear the **Show legends** checkbox.
Add a marker in the computed data points.
- 4 Click to expand the **Coloring and Style** section. Find the **Line markers** subsection. From the **Marker** list, choose **Point**.

- 5 Locate the **x-Axis Data** section. From the **Parameter** list, choose **Expression**.
- 6 In the **Expression** text field, type D.

Change the axis titles. Note that html tags and a range of mathematical symbols and Greek letters can be entered in the axis and plot titles.

Output Concentration (Uncoupled Flow)

- 1 In the **Model Builder** window, click **Output Concentration (Uncoupled Flow)**.
- 2 In the **Settings** window for **ID Plot Group**, click to expand the **Title** section.
- 3 From the **Title type** list, choose **None**.
- 4 Locate the **Plot Settings** section.
- 5 Select the **x-axis label** checkbox. In the associated text field, type Diffusion Coefficient (m^{2}/s).
- 6 Select the **y-axis label** checkbox. In the associated text field, type Concentration at Stream B Outlet (mol/m^{3}).

Change the axis limits for the plot.

- 7 Locate the **Axis** section. Select the **Manual axis limits** checkbox.
- 8 In the **y minimum** text field, type 0.
- 9 In the **y maximum** text field, type 0.5.
- 10 In the **Output Concentration (Uncoupled Flow)** toolbar, click  **Plot**.

This plot shows that the concentration of the species at the output is strongly dependent on the diffusion coefficient of the molecule. Thus the device could be used to separate species with different diffusion coefficients, particularly if multiple stages of the device were arranged in series.

In some cases, particularly if the solution consists of large macromolecules, the dissolved species has a large influence on the liquid's viscosity. In such situations, the Navier–

Stokes and the convection–diffusion equations become coupled, and so they must be solved simultaneously.

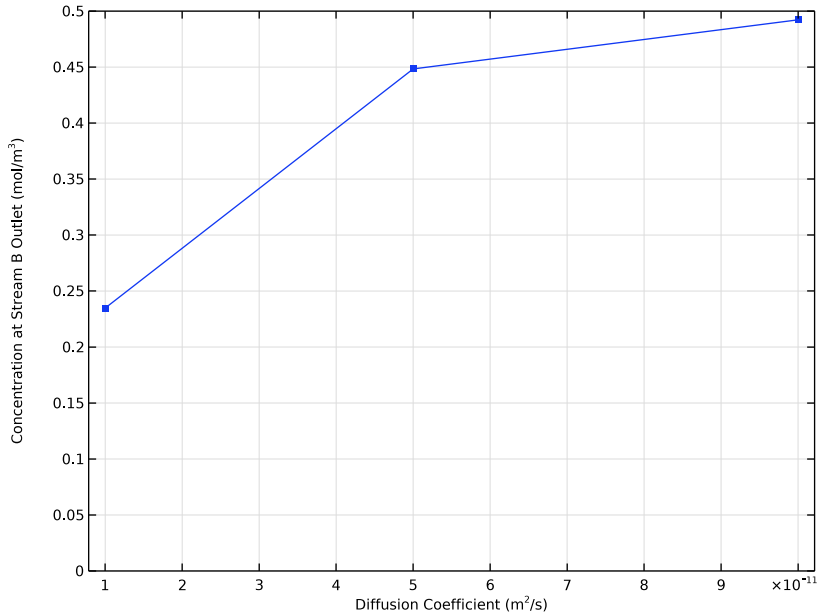

Add a new **Fluid Properties** node that will be used to set up the fully coupled problem. To make the viscosity a function of the species concentration simply type an expression into the **Dynamic viscosity** field of the **Fluid Properties** node.

CREEPING FLOW (SPF)

Fluid Properties: Uncoupled

- 1 In the **Model Builder** window, under **Component 1 (comp1) > Creeping Flow (spf)** click **Fluid Properties 1**.
- 2 In the **Settings** window for **Fluid Properties**, type Fluid Properties: Uncoupled in the **Label** text field.

Fluid Properties: Coupled

- 1 Right-click **Fluid Properties: Uncoupled** and choose **Duplicate**.
- 2 In the **Settings** window for **Fluid Properties**, type Fluid Properties: Coupled in the **Label** text field.
- 3 Locate the **Fluid Properties** section. From the μ list, choose **User defined**. In the associated text field, type $1e-3[\text{Pa}\cdot\text{s}]\cdot(1+\alpha\cdot c^2)$.



Deactivate the **Fluid Properties: Coupled** node in **Study 1** to be able to reproduce the uncoupled results in the future. Then, add a new study to solve the fully coupled problem. In this instance only a single diffusion coefficient will be solved for, so no parametric sweep will be required. The model will default to the parameter entered on the **Parameters** node for the diffusion constant: $5e-11 \text{ m}^2/\text{s}$.

STUDY 1

Step 1: Stationary

- 1 In the **Model Builder** window, under **Study 1** click **Step 1: Stationary**.
- 2 In the **Settings** window for **Stationary**, locate the **Physics and Variables Selection** section.
- 3 Select the **Modify model configuration for study step** checkbox.
- 4 In the tree, select **Component 1 (comp1) > Creeping Flow (spf) > Fluid Properties: Coupled**.
- 5 Right-click and choose **Disable**.

ADD STUDY

- 1 In the **Home** toolbar, click  **Add Study** to open the **Add Study** window.
- 2 Go to the **Add Study** window.
- 3 Find the **Studies** subsection. In the **Select Study** tree, select **General Studies > Stationary**.
- 4 Click the **Add Study** button in the window toolbar.
- 5 In the **Home** toolbar, click  **Add Study** to close the **Add Study** window.

STUDY 2

Turn off the default plot groups again.

- 1 In the **Settings** window for **Study**, locate the **Study Settings** section.
- 2 Clear the **Generate default plots** checkbox.
- 3 In the **Study** toolbar, click  **Compute**.

Add another surface dataset that points to the new solution.

RESULTS

Surface 2

- 1 In the **Model Builder** window, under **Results > Datasets** right-click **Surface 1** and choose **Duplicate**.
- 2 In the **Settings** window for **Surface**, locate the **Data** section.
- 3 From the **Dataset** list, choose **Study 2/Solution 3 (sol3)**.

Recreate the velocity, pressure and concentration plots for the fully coupled problem.

Velocity (Coupled Flow)

- 1 In the **Model Builder** window, right-click **Velocity (Uncoupled Flow)** and choose **Duplicate**.
- 2 In the **Settings** window for **3D Plot Group**, type Velocity (Coupled Flow) in the **Label** text field.
- 3 Locate the **Data** section. From the **Dataset** list, choose **Study 2/Solution 3 (sol3)**.
- 4 In the **Velocity (Coupled Flow)** toolbar, click  **Plot**.

There are significant differences in the flow pattern, although these are hard to see when comparing this plot with the similar one generated previously. The flow through a slice of the channel will be investigated in more detail later to better highlight these differences.

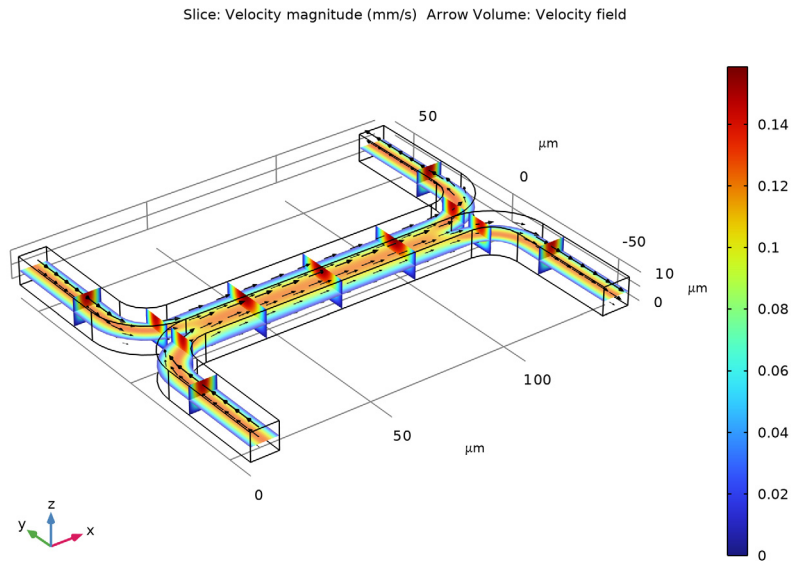

Pressure (Coupled Flow)

- 1 In the **Model Builder** window, right-click **Pressure (Uncoupled Flow)** and choose **Duplicate**.
- 2 In the **Settings** window for **3D Plot Group**, type Pressure (Coupled Flow) in the **Label** text field.
- 3 Locate the **Data** section. From the **Dataset** list, choose **Surface 2**.

- 4 In the **Pressure (Coupled Flow)** toolbar, click  **Plot**.

The pressure distribution in the channel has changed significantly as a result of the increased viscosity of the fluid that contains the added species. Thus the two inlets must be maintained at different pressures. This may be possible for a single stage, but it would significantly complicate the design of a multiple stage device.

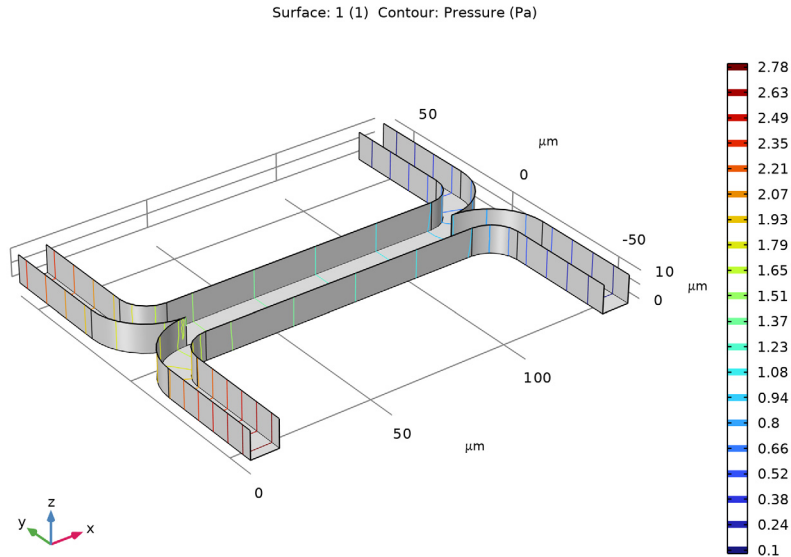

Concentration (Coupled Flow)

- 1 In the **Model Builder** window, right-click **Concentration (Uncoupled Flow)** and choose **Duplicate**.
- 2 In the **Settings** window for **3D Plot Group**, type **Concentration (Coupled Flow)** in the **Label** text field.
- 3 Locate the **Data** section. From the **Dataset** list, choose **Study 2/Solution 3 (sol3)**.

4 In the **Concentration (Coupled Flow)** toolbar, click  **Plot**.

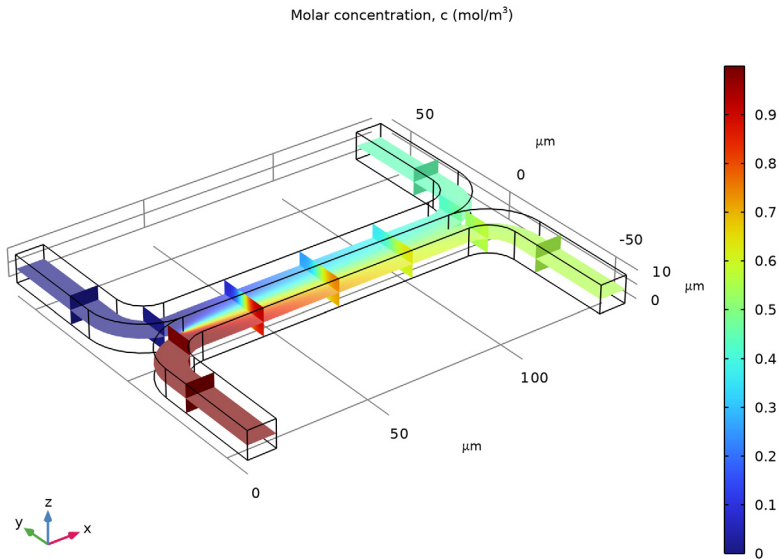

The concentration distribution is affected only slightly by the coupling between the flow and the concentration.

Next add a **Cut Plane** dataset in the center of the channel, for both the uncoupled and fully coupled solutions. These will be used to visualize the change in the flow profile induced by the coupling.

Cut Plane 1

- 1 In the **Results** toolbar, click  **Cut Plane**.
- 2 In the **Settings** window for **Cut Plane**, locate the **Plane Data** section.
- 3 In the **x-coordinate** text field, type 70.

Cut Plane 2

- 1 Right-click **Cut Plane 1** and choose **Duplicate**.
- 2 In the **Settings** window for **Cut Plane**, locate the **Data** section.
- 3 From the **Dataset** list, choose **Study 2/Solution 3 (sol3)**.

Cut Plane 1

Then add a **Contour** plot of the velocity magnitude.

Velocity Comparison

- 1 In the **Results** toolbar, click  **2D Plot Group**.
- 2 In the **Settings** window for **2D Plot Group**, type **Velocity Comparison** in the **Label** text field.
- 3 Locate the **Data** section. From the **Dataset** list, choose **Cut Plane 1**.
- 4 From the **Parameter value (D (m²/s))** list, choose **5E-11**.

Contour 1

- 1 Right-click **Velocity Comparison** and choose **Contour**.
- 2 In the **Settings** window for **Contour**, locate the **Levels** section.
- 3 In the **Total levels** text field, type 5.

Create a duplicate **Contour** plot, using the same colors and scales, but showing the coupled data.

Contour 2

- 1 Right-click **Contour 1** and choose **Duplicate**.
- 2 In the **Settings** window for **Contour**, locate the **Data** section.
- 3 From the **Dataset** list, choose **Cut Plane 2**.
- 4 Click to expand the **Title** section. From the **Title type** list, choose **None**.
- 5 Locate the **Coloring and Style** section. Clear the **Color legend** checkbox.
- 6 Click to expand the **Inherit Style** section. From the **Plot** list, choose **Contour 1**.
- 7 In the **Velocity Comparison** toolbar, click  **Plot**.

8 Click the  **Zoom Extents** button in the **Graphics** toolbar.

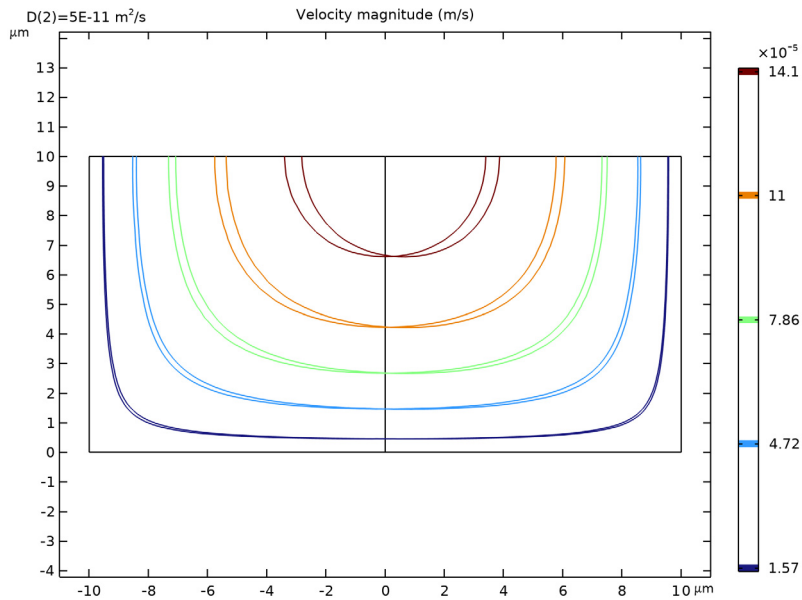

Now it is possible to compare the velocity distributions more carefully. It is clear that the coupling has introduced an asymmetry into the flow pattern, as a result of the higher viscosity in the fluid containing the dissolved species.

Finally compare the output concentration between the two solutions.

Global Evaluation 1



- 1 In the **Results** toolbar, click  **Global Evaluation**.
- 2 In the **Settings** window for **Global Evaluation**, click **Replace Expression** in the upper-right corner of the **Expressions** section. From the menu, choose **Component 1 (comp1) > Transport of Diluted Species > Outflow 2 > tds.out2.c0_avg_c - Average concentration - mol/m³**.
- 3 Click  **Evaluate**.

TABLE I

Go to the **Table I** window.

Global Evaluation 2

- 1 Right-click **Global Evaluation 1** and choose **Duplicate**.
- 2 In the **Settings** window for **Global Evaluation**, locate the **Data** section.

3 From the **Dataset** list, choose **Study 2/Solution 3 (sol3)**.

4 Click ▼ next to **⌘ Evaluate**, then choose **New Table**.

Only a small difference occurs in the output concentration as a result of the coupling between the problems. However the coupling would make adding multiple stages of the device together much more difficult, as different pressures are required at the two inlets to obtain the same flow velocity in the two streams.