



Model created in COMSOL Multiphysics 6.4

# Thickness Shear Mode Quartz Oscillator

## Introduction

---

AT cut quartz crystals are widely employed in a range of applications, from oscillators to microbalances. One of the important properties of the AT cut is that the resonant frequency of the crystal is temperature independent to first order. This is desirable in both mass sensing and timing applications. AT cut crystals vibrate in the thickness shear mode — an applied voltage across the faces of the cut produces shear stresses inside the crystal. This example considers the vibration of an AT cut thickness shear oscillator, focusing on the mechanical response of the system in the frequency domain. The effect of a series capacitor on the mechanical resonance is also considered. Adding a series capacitance is a technique frequently employed to tune crystal oscillators.

## Model Definition

---

The model geometry is shown in [Figure 1](#). The oscillator consists of a single (left-handed) quartz disc, supported so as not to impede the motion of the vibrational mode. There are two electrodes on the top and bottom surfaces of the geometry, one of which is grounded.

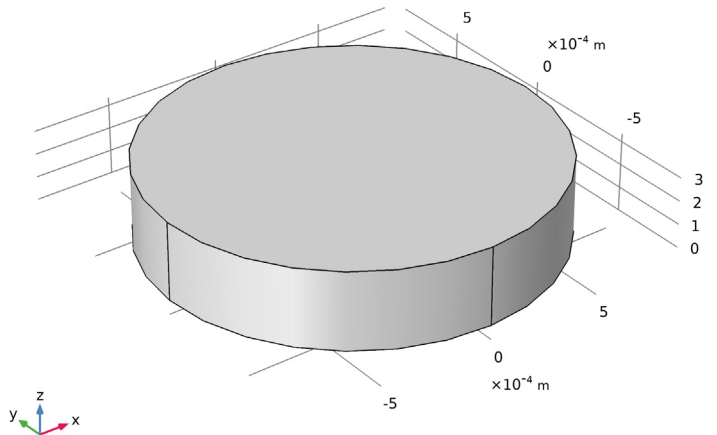

*Figure 1: Model geometry.*

In the first version of the model an AC voltage is applied to the top electrode. In the second version, the crystal is still driven by an AC voltage, but a capacitor is placed between the voltage source and the top electrode of the crystal.

### DOMAIN LEVEL EQUATIONS

Within a piezoelectric crystal there is a coupling between the strain and the electric field, which is determined by the constitutive relation

$$\begin{aligned}\mathbf{T} &= c_E \mathbf{S} - e^T \mathbf{E} \\ \mathbf{D} &= e \mathbf{S} + \epsilon_S \mathbf{E}\end{aligned}\tag{1}$$

Here,  $\mathbf{S}$  is the strain,  $\mathbf{T}$  is the stress,  $\mathbf{E}$  is the electric field, and  $\mathbf{D}$  is the electric displacement field. The material parameters  $c_E$ ,  $e$ , and  $\epsilon_S$ , correspond to the material stiffness, the coupling properties, and the permittivity. These quantities are tensors of rank 4, 3, and 2, respectively, but, since the tensors are highly symmetric for physical reasons, they can be represented as matrices within an abbreviated subscript notation, which is usually more convenient. Equation 1 is implemented by the **Piezoelectricity** coupling. This constitutive relation is used to couple the equations of **Solid Mechanics** and **Electrostatics**, which are solved within the material.

### MATERIAL ORIENTATION

The orientation of a piezoelectric crystal cut is frequently defined by the system introduced by the IRE standard of 1949 (Ref. 1). This standard has undergone a number of subsequent revisions, with the final revision being the IEEE standard of 1987 (Ref. 2). Unfortunately the 1987 standard contained a number of serious errors and the IEEE subsequently withdrew it. COMSOL Multiphysics therefore adopts the preceding 1978 standard (Ref. 3), which is similar to the 1987 standard, for material property definitions. Most of the material properties in the material library are based on the values given in the book by Auld (Ref. 4), which uses the 1978 IEEE conventions. This is consistent with general practice except in the specific case of quartz, where it is more common to use the 1949 IRE standard to define the material properties. COMSOL Multiphysics therefore provides an additional set of material properties consistent with the 1949 standard for the case of quartz. Note that the material properties for quartz are based on Ref. 5, which uses the 1949 IRE standard (the properties are appropriately modified according to the different standards).

In COMSOL Multiphysics, the stiffness, compliance, coupling, and dielectric material property matrices are defined with respect to the crystal axes. Because the crystal axes for quartz were defined differently between the IRE 1949 and the IEEE 1978 standards (see Figure 3), the signs of several matrix components differ between the two standards (see Table 1). In the absence of a user-defined coordinate system, the crystal axes coincide with the global  $X_g$ ,  $Y_g$ , and  $Z_g$  coordinate axes (the axes shown in the COMSOL Desktop geometry window). When an alternative coordinate system is selected, this system defines the orientation of the crystal axes. This is the mechanism used in COMSOL Multiphysics to define a particular crystal cut, and typically it is necessary to calculate the appropriate Euler angles for the cut (given the thickness orientation for the wafer).

All piezoelectric material properties are defined using the Voigt form of the abbreviated subscript notation, which is universally employed in the literature (this differs from the standard notation used for **Linear Elastic Material** feature in the **Solid Mechanics** interface). The material properties are defined in the material frame, so that if the solid rotates during deformation the material properties rotate with the solid.

Crystal cuts are usually defined by a mechanism introduced by the IEEE/IRE standards. Both standards use a notation that defines the orientation of a virtual slice (the plate) through the crystal. The crystal axes are denoted  $X$ ,  $Y$ , and  $Z$  and the plate, which is usually rectangular, is defined as having sides  $l$ ,  $w$ , and  $t$  (length, width, and thickness). Initially the plate is aligned with respect to the crystal axes and then up to three rotations are defined, using a right-handed convention about axes embedded along the  $l$ ,  $w$ , and  $t$  sides of the plate.

This tutorial uses AT cut quartz, defined in the IEEE 1978 standard as:  $(YXl) -35.25^\circ$ . The first two letters in the bracketed expression always refer to the initial orientation of the thickness ( $t$ ) and the length ( $l$ ) of the plate. Subsequent bracketed letters then define up to three rotational axes, which move with the plate as it is rotated. Angles of rotation about these axes are specified after the bracketed expression in the order of the letters, using a right-handed convention. For AT cut quartz only one rotation, about the  $l$  axis, is required. This is illustrated in [Figure 2](#).

[Figure 3](#) shows the final orientation of the plate with respect to the crystal for the AT cut quartz, according to both standards. In this figure, for clarity, the crystal axes labels  $X$ ,  $Y$ , and  $Z$  are appended with a subscript “cr” ( $X_{cr}$ ,  $Y_{cr}$ , and  $Z_{cr}$ ). Note that within the 1949 IRE Standard, AT cut quartz is defined as:  $(YXl) +35.25^\circ$ . As shown in [Figure 3](#), the final orientation of the plate ( $l$ ,  $w$ , and  $t$  axes) are not the same between the two standards.

[Table 2](#) summarizes the differences between the standards for the AT cut.



---

When defining the material properties of quartz, the orientation of the crystal axes  $X$ ,  $Y$ , and  $Z$  with respect to the crystal differs between the 1978 IEEE standard and the 1949 IRE standard, as shown in [Figure 3](#). (In the figure the crystal axes  $X$ ,  $Y$ , and  $Z$  are labeled as  $X_{cr}$ ,  $Y_{cr}$ , and  $Z_{cr}$  for clarity.) A consequence of this is that both the material property matrices and the crystal cut differ between the two standards. [Table 1](#) summarizes the signs for the important matrix elements under the two conventions. [Table 2](#) shows the different definitions of the crystal cuts under the two conventions.

---

TABLE 1: SIGNS FOR THE MATERIAL PROPERTIES OF QUARTZ, WITHIN THE TWO STANDARDS COMMONLY EMPLOYED.

| MATERIAL PROPERTY | IRE 1949 STANDARD   |                    | IEEE 1978 STANDARD  |                    |
|-------------------|---------------------|--------------------|---------------------|--------------------|
|                   | RIGHT-HANDED QUARTZ | LEFT-HANDED QUARTZ | RIGHT-HANDED QUARTZ | LEFT-HANDED QUARTZ |
| $s_{14}$          | +                   | +                  | -                   | -                  |
| $c_{14}$          | -                   | -                  | +                   | +                  |
| $d_{11}$          | -                   | +                  | +                   | -                  |
| $d_{14}$          | -                   | +                  | -                   | +                  |
| $e_{11}$          | -                   | +                  | +                   | -                  |
| $e_{14}$          | +                   | -                  | +                   | -                  |

TABLE 2: CRYSTAL CUT DEFINITIONS FOR QUARTZ CUTS WITHIN THE TWO STANDARDS COMMONLY EMPLOYED AND THE CORRESPONDING EULER ANGLES FOR DIFFERENT ORIENTATIONS OF THE CRYSTAL THICKNESS.

| STANDARD  | REPRESENTATION           | AT CUT                                   |
|-----------|--------------------------|--|
| IRE 1949  | Standard                 | $(YXI) +35.25^\circ$                     |
|           | Y-thickness Euler angles | $(ZZZ: 0^\circ, -35.25^\circ, 0^\circ)$  |
|           | Z-thickness Euler angles | $(ZZZ: 0^\circ, +54.75^\circ, 0^\circ)$  |
| IEEE 1978 | Standard                 | $(YXI) -35.25^\circ$                     |
|           | Y-thickness Euler angles | $(ZZZ: 0^\circ, +35.25^\circ, 0^\circ)$  |
|           | Z-thickness Euler angles | $(ZZZ: 0^\circ, +125.25^\circ, 0^\circ)$ |

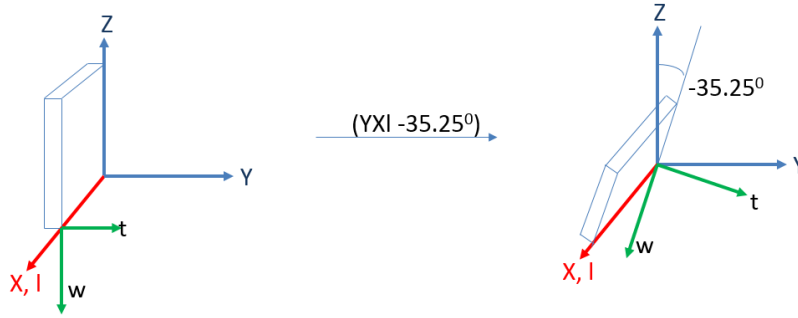

Figure 2: Definition of the AT cut of quartz within the IEEE 1978 standard. It is defined as:  $(YXI) -35.25^\circ$ . The first two bracketed letters specify the initial orientation of the plate, with the thickness direction ( $t$ ) along the crystal  $Y$  axis, and the length direction ( $l$ ) along the  $X$  axis. Then up to three rotations about axes that move with the plate are specified by the corresponding bracketed letters and the subsequent angles. In this case only one rotation is required about the  $l$  axis, of  $-35.25^\circ$  (in a right-handed sense).

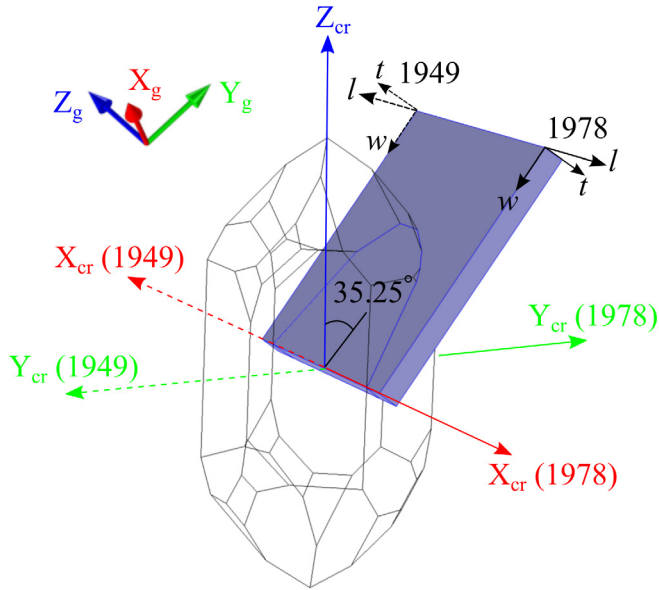

Figure 3: Summary of two standards for AT cut quartz and the coordinate systems involved in the model setup. The cut plate is in its final orientation ( $l, w, t$ ), after a single rotation of  $35.25^\circ$  from the crystal axes ( $X_{cr}, Y_{cr}, Z_{cr}$ ), according to the standards. The global coordinate system ( $X_g, Y_g, Z_g$ ) is given by the orientation of the plate in the model geometry, which can be quite arbitrary as illustrated in the figure.

In general, when setting up a COMSOL model involving crystal cuts, there are three coordinate systems and three sets of relationships among them to be considered, as summarized in Figure 3.

- 1 The IRE or IEEE standard defines the relationship between the crystal axes ( $X_{cr}, Y_{cr}, Z_{cr}$ ) and the plate axes ( $l, w, t$ ).
- 2 When creating a COMSOL Multiphysics model, we draw the plate in the geometry window, thereby implicitly defines the relationship between the plate axes ( $l, w, t$ ) and the global axes ( $X_g, Y_g, Z_g$ ). If the plate is oriented differently in the model geometry, then this relationship will also be different.
- 3 Using the two relationships above, we can determine the relationship between the crystal axes ( $X_{cr}, Y_{cr}$ , and  $Z_{cr}$ ) and the global axes ( $X_g, Y_g$ , and  $Z_g$ ).

Using this final relationship, we create a local coordinate system that coincides with the crystal axes ( $X_{cr}, Y_{cr}$ , and  $Z_{cr}$ ), to specify the material orientation, so that the crystal cut in the model is consistent with the standard shown in the figure.

For a specific example, consider the IEEE 1978 standard for AT cut quartz as shown in Figure 2 and Figure 3. As discussed in 2 above, the definition of the appropriate local coordinate system depends on the desired final orientation of the plate in the global coordinate system (how the plate is drawn in the geometry window). One way to set up the plate is to orient its normal ( $t$ ) along the  $Y_g$  axis in the global coordinate system, as shown in Figure 4(b). Another way is to orient the plate normal ( $t$ ) along the global  $Z_g$  axis, which is the case for the crystal in this model (as in Figure 4(a)). By comparing Figure 4(a) and (b), it is clear that the orientation of the local system (the crystal axes  $X_{cr}$ ,  $Y_{cr}$ , and  $Z_{cr}$ ) with respect to the global system ( $X_g$ ,  $Y_g$ , and  $Z_g$ ) is different between the two configurations. Therefore it is critical to keep track of this relationship between the local and global system when setting up a model.

There are several methods available to define the local coordinate system with respect to the global system in a model. Usually it is most convenient to define the local coordinates with a **Rotated System** node, which defines three Euler angles according to the *ZZZ* convention (rotation about  $Z$ , then rotated- $X$ , then rotated- $Z$ ). Note that these Euler angles define the rotation starting from the global axes and ending at the local (crystal) axes, as shown in Figure 5. This is distinct from the IRE/IEEE standards that starts the rotation from the crystal (local) axes and ends at the plate axes, as shown in Figure 2.

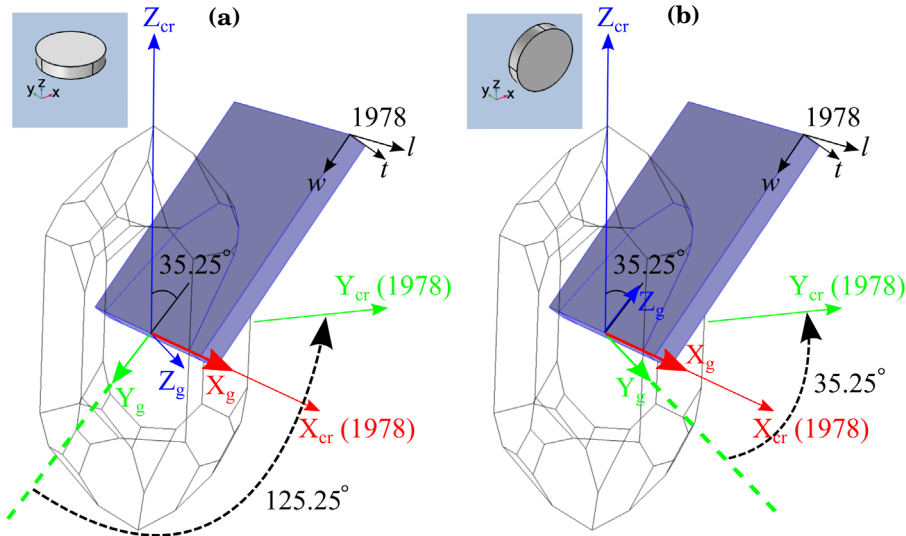

Figure 4: For the same AT cut of quartz within the IEEE 1978 standard, there are many different possible ways to orient the plate in the model geometry. The thickness direction ( $t$ ) can be aligned with the global  $Z_g$  axis (a), or the global  $Y_g$  axis (b). This results in different Euler angles:  $125.25^\circ$  for the former and  $35.25^\circ$  for the latter. The insets show the plate orientation as seen in the model geometry window.

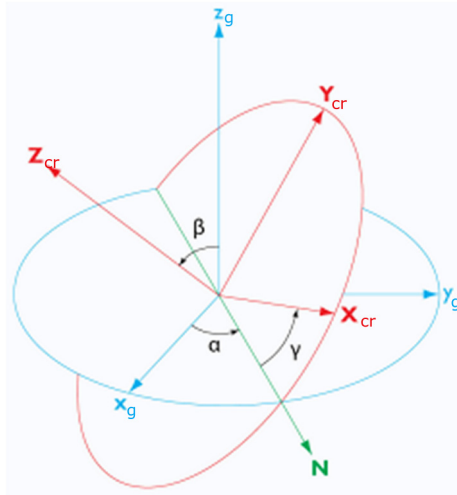

Figure 5: According to the ZYZ convention adopted by COMSOL Multiphysics, the Euler angles ( $\alpha$ ,  $\beta$ ,  $\gamma$ ) define three successive rotations starting from the global axes ( $X_g$ ,  $Y_g$ , and  $Z_g$ ) and ending at the local (crystal) axes ( $X_{cr}$ ,  $Y_{cr}$ , and  $Z_{cr}$ ).

From Figure 4 it can be seen that for the AT cut quartz, if the plate thickness direction ( $t$ ) is along the global  $Z_g$  axis (a), or the global  $Y_g$  axis (b), then only one nontrivial Euler rotation about the  $X_g$  axis is required to bring the global axes ( $X_g$ ,  $Y_g$ , and  $Z_g$ ) to align with the crystal (local) axes ( $X_{cr}$ ,  $Y_{cr}$ , and  $Z_{cr}$ ). For these two relatively simple cases, the Euler angles can be easily determined: (ZZZ:  $0^\circ$ ,  $+125.25^\circ$ ,  $0^\circ$ ) for (a) and (ZZZ:  $0^\circ$ ,  $+35.25^\circ$ ,  $0^\circ$ ) for (b), as shown in the figure and Table 2.

## ELECTRICAL CIRCUIT

In the first part of the model an AC voltage is applied directly to the top plate of the oscillator, which is grounded. In the second part of the model, a capacitor is added between the voltage source and the oscillator, as shown in Figure 6. In COMSOL Multiphysics, the oscillator is coupled into the circuit using the **External I Terminal** feature.

The terminal boundary condition within the model is set to **Circuit** and this feature then captures the charge generated by the circuit.

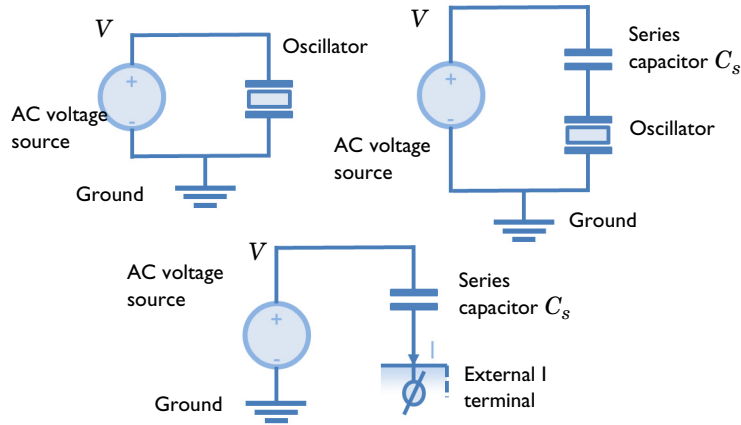
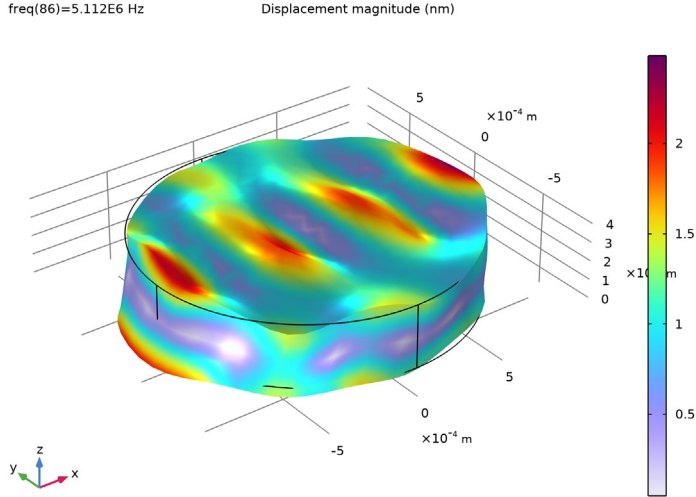

Figure 6: Upper left: Electrical circuit for the first part of the model. Upper right: Electrical circuit for the second part of the model. Bottom: Circuit for the second part of the model as implemented in COMSOL Multiphysics.

## Results and Discussion

Figure 7 shows the crystal displacement at its resonant frequency of 5.11 MHz. The form of the displacement shows clearly the shear nature of the resonance. The potential on cut slices through the plate is illustrated in Figure 8. The mechanical domain frequency response of the oscillator is shown in Figure 9. A clear resonance is apparent, with a resonant frequency close to 5.11 MHz.

The addition of a series capacitance between the oscillator and the voltage source is expected to pull the resonant frequency to higher values. Figure 10 shows this effect, with the resonant frequency increasing the most for smaller values of the series capacitance (in the limit of very large series capacitance the impedance of the series capacitor goes to zero and produces the result shown in Figure 9).



*Figure 7: Displacement of the crystal at resonance.*

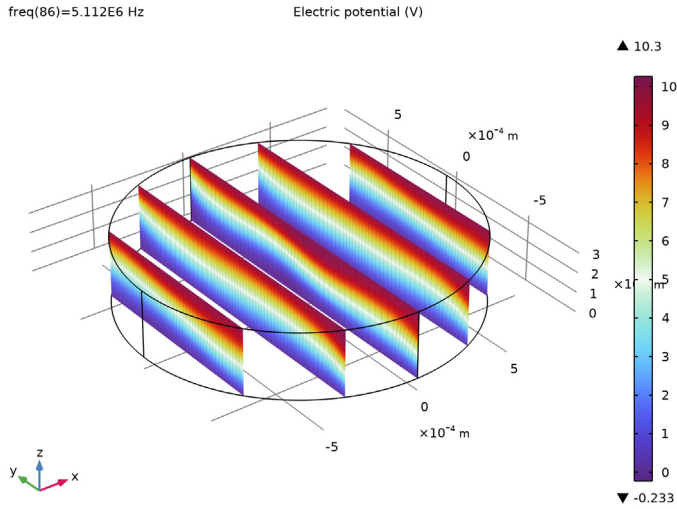

*Figure 8: Electric potential inside the crystal at resonance.*

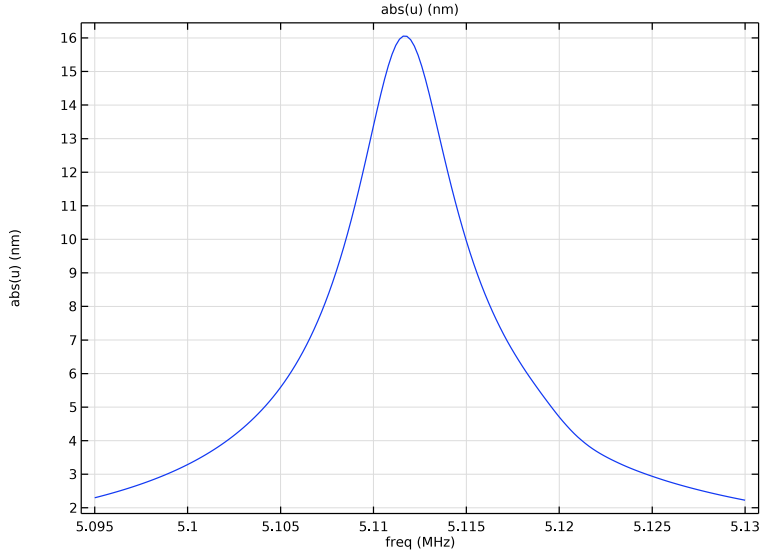

Figure 9: Mechanical response of the structure with no series capacitance.

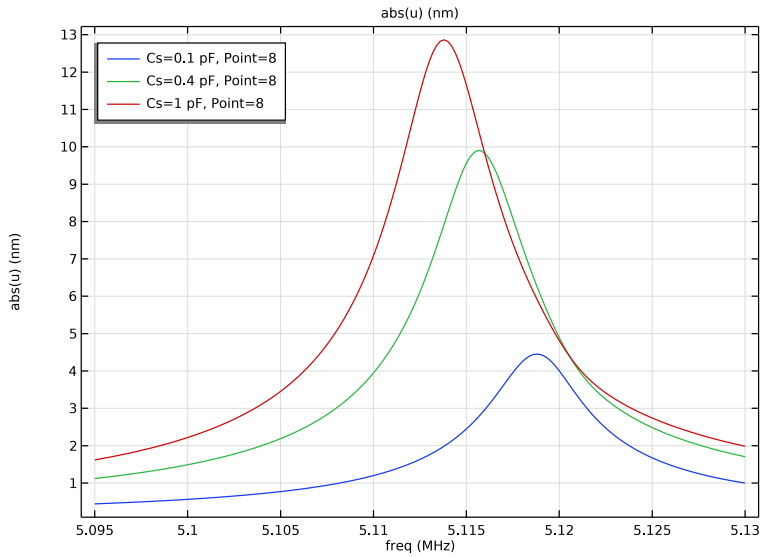

Figure 10: Mechanical response of the structure with different series capacitances.

## References

---

1. “Standards on Piezoelectric Crystals, 1949,” *Proceedings of the I. R. E.*, vol. 37, no. 12, pp. 1378–1395, 1949.
  2. *ANSI/IEEE Standard 176-1987, Piezoelectricity*, IEEE, 1988.
  3. *ANSI/IEEE Standard 176-1978, Piezoelectricity*, IEEE, 1978.
  4. B.A. Auld, *Acoustic Fields and Waves in Solids*, Krieger Publishing Company, 1990.
  5. R. Bechmann, “Elastic and Piezoelectric Constants of Alpha-Quartz,” *Phys. Rev. B*, vol. 110 no. 5, pp. 1060–1061, 1958.
- 

**Application Library path:** MEMS\_Module/Piezoelectric\_Devices/  
thickness\_shear\_quartz\_oscillator

---

## Modeling Instructions

---

From the **File** menu, choose **New**.

### NEW

In the **New** window, click  **Model Wizard**.

### MODEL WIZARD

- 1 In the **Model Wizard** window, click  **3D**.
- 2 In the **Select Physics** tree, select **Structural Mechanics > Electromagnetics–Structure Interaction > Piezoelectricity > Piezoelectricity, Solid**.

- 3 Click **Add**.

We will select the **Adaptive Frequency Sweep** study step later.

- 4 Click  **Done**.

### GEOMETRY I

Add parameters for the model geometry and series capacitance.

### GLOBAL DEFINITIONS

#### Parameters I

- 1 In the **Model Builder** window, under **Global Definitions** click **Parameters I**.

- 2 In the **Settings** window for **Parameters**, locate the **Parameters** section.
- 3 In the table, enter the following settings:



| Name | Expression | Value     | Description          |
|------|------------|-----------|----------------------|
| Cs   | 1 [pF]     | 1E-12 F   | Series capacitance   |
| RO   | 835 [um]   | 8.35E-4 m | Oscillator radius    |
| HO   | 334 [um]   | 3.34E-4 m | Oscillator thickness |

Instead of building the geometry from scratch, import a prebuilt mesh. This showcases a less-known functionality of COMSOL Multiphysics to create and solve a model from imported mesh without needing any geometry object to be created.

To keep the computational time and RAM requirements as low as possible, we use a coarse mesh. For this kind of high-Q systems, a much finer mesh is required for the resonant structure to be truly converged.

## MESH I

### Import I

- 1 In the **Mesh** toolbar, click  **Import**.
- 2 In the **Settings** window for **Import**, locate the **Import** section.
- 3 Click  **Browse**.
- 4 Browse to the model's Application Libraries folder and double-click the file `thickness_shear_quartz_oscillator_mesh.mphbin`.
- 5 Click  **Import**.

Create an operator to evaluate quantities on a point for the **Adaptive Frequency Sweep** study step.

## DEFINITIONS

### Integration I (intop1)

- 1 In the **Definitions** toolbar, click  **Nonlocal Couplings** and choose **Integration**.
- 2 In the **Settings** window for **Integration**, locate the **Source Selection** section.
- 3 From the **Geometric entity level** list, choose **Point**.
- 4 Select Point 8 only.

The **Adaptive Frequency Sweep** study step will generate a high resolution frequency sweep. To avoid large file size, create an "explicit selection" to store solution data only on the external surfaces of the modeling domain.



### *All surfaces*

- 1 In the **Definitions** toolbar, click  **Explicit**.
- 2 In the **Settings** window for **Explicit**, type A11 surfaces in the **Label** text field.
- 3 Locate the **Input Entities** section. From the **Geometric entity level** list, choose **Boundary**.
- 4 Select the **All boundaries** checkbox.  
Set up a rotated system appropriate for AT cut Quartz.

### *Rotated System 2 (sys2)*

- 1 In the **Definitions** toolbar, click  **Coordinate Systems** and choose **Rotated System**.
- 2 In the **Settings** window for **Rotated System**, locate the **Rotation** section.
- 3 Find the **Euler angles** subsection. In the  $\beta$  text field, type 125.25[deg].

### **ADD MATERIAL**

- 1 In the **Materials** toolbar, click  **Add Material** to open the **Add Material** window.
- 2 Go to the **Add Material** window.
- 3 In the tree, select **Piezoelectric > Quartz LH (1978 IEEE)**.
- 4 Click the **Add to Component** button in the window toolbar.
- 5 In the **Materials** toolbar, click  **Add Material** to close the **Add Material** window.

### **SOLID MECHANICS (SOLID)**

Use the rotated system to define the orientation of the crystal.

### *Piezoelectric Material 1*

- 1 In the **Model Builder** window, under **Component 1 (comp1) > Solid Mechanics (solid)** click **Piezoelectric Material 1**.
- 2 In the **Settings** window for **Piezoelectric Material**, locate the **Coordinate System Selection** section.
- 3 From the **Coordinate system** list, choose **Rotated System 2 (sys2)**.  
Add damping to the model.

### *Mechanical Damping 1*

- 1 In the **Physics** toolbar, click  **Attributes** and choose **Mechanical Damping**.
- 2 In the **Settings** window for **Mechanical Damping**, locate the **Damping Settings** section.
- 3 From the **Damping type** list, choose **Isotropic loss factor**.
- 4 From the  $\eta_s$  list, choose **User defined**. In the associated text field, type 1e-3.

## ELECTROSTATICS (ES)

Add electrical boundary conditions to the model. First add a **Boundary Terminal** feature that connects the electrode to an external circuit.

- 1 In the **Model Builder** window, under **Component 1 (comp1)** click **Electrostatics (es)**.

### *Boundary Terminal 1*

- 1 In the **Physics** toolbar, click  **Boundaries** and choose **Boundary Terminal**.
- 2 Select Boundary 4 only.
- 3 In the **Settings** window for **Boundary Terminal**, locate the **Terminal** section.
- 4 From the **Terminal type** list, choose **Circuit**.

Override the preceding boundary condition with a constant potential boundary condition to compute the response of the device without a series capacitance. This node will be disabled in the study when the circuit is included in the model.

### *Boundary Terminal 2*

- 1 In the **Physics** toolbar, click  **Boundaries** and choose **Boundary Terminal**.
- 2 In the **Settings** window for **Boundary Terminal**, locate the **Terminal** section.
- 3 In the **Terminal name** text field, type 1.
- 4 Select Boundary 4 only.
- 5 From the **Terminal type** list, choose **Voltage**.
- 6 In the  $V_0$  text field, type 10.



### *Ground 1*

- 1 In the **Physics** toolbar, click  **Boundaries** and choose **Ground**.
- 2 Select Boundary 3 only.

## ROOT

In the second study in this model, the effect of a series capacitor on the device response will be investigated. Add an **Electrical Circuit** interface to model the capacitor.

## ADD PHYSICS

- 1 In the **Home** toolbar, click  **Add Physics** to open the **Add Physics** window.
- 2 Go to the **Add Physics** window.
- 3 In the tree, select **AC/DC > Electrical Circuit (cir)**.
- 4 Click the **Add to Component 1** button in the window toolbar.
- 5 In the **Home** toolbar, click  **Add Physics** to close the **Add Physics** window.

## ELECTRICAL CIRCUIT (CIR)

Features in the **Electrical Circuit** interface are connected by specifying connecting node numbers for each port of the device.

### Ground Node 1 (gnd1)

A ground node is automatically added to the circuit, with the default node number of 0.

Next add a voltage source between the ground node and a (newly created) node with number 2.

### Voltage Source 1 (V1)

1 In the **Electrical Circuit** toolbar, click  **Voltage Source**.

2 In the **Settings** window for **Voltage Source**, locate the **Node Connections** section.

3 In the table, enter the following settings:

| Label | Node names |
|-------|------------|
| p     | 2          |
| n     | 0          |

4 Locate the **Device Parameters** section. From the **Source type** list, choose **AC-source**.

5 In the  $v_{src}$  text field, type 10.

Add a capacitor between the voltage source output (node 2) and a new node, 1.

### Capacitor 1 (C1)

1 In the **Electrical Circuit** toolbar, click  **Capacitor**.

2 In the **Settings** window for **Capacitor**, locate the **Node Connections** section.

3 In the table, enter the following settings:

| Label | Node names |
|-------|------------|
| p     | 2          |
| n     | 1          |

4 Locate the **Device Parameters** section. In the  $C$  text field, type 0s.

Connect node 1 to the **Terminal** feature in the model using the **External I-Terminal** feature.

### External I-Terminal 1 (term1)

1 In the **Electrical Circuit** toolbar, click  **External I-Terminal**.

Couple the electric potential from the **Terminal** in the electrostatics interface back into the model.

- 2 In the **Settings** window for **External I-Terminal**, locate the **Node Connections** section.
- 3 In the **Node name** text field, type 1.
- 4 Locate the **External Terminal** section. From the *V* list, choose **Terminal voltage (es)**.

#### MESH 1

- 1 In the **Model Builder** window, under **Component 1 (comp1)** click **Mesh 1**.

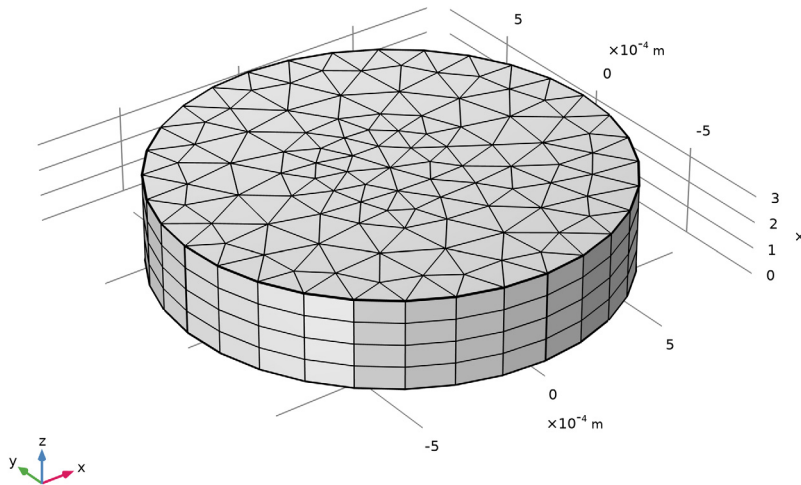



The mesh used here is somewhat coarse for this kind of high-Q systems. The reason is mainly to keep the computational time and RAM requirements as low as possible.

Interested users are encouraged to solve the problem for finer mesh settings.

Set up and solve an **Adaptive Frequency Sweep** study, which is optimized for resolving narrow resonant peaks without excessive computation.

#### ADD STUDY

- 1 In the **Home** toolbar, click  **Add Study** to open the **Add Study** window.
- 2 Go to the **Add Study** window.
- 3 Find the **Studies** subsection. In the **Select Study** tree, select **Empty Study**.
- 4 Click the **Add Study** button in the window toolbar.
- 5 In the **Home** toolbar, click  **Add Study** to close the **Add Study** window.

## STUDY 1

### Step 1: Adaptive Frequency Sweep

- 1 In the **Study** toolbar, click  **More Study Steps** and choose **Frequency Domain > Adaptive Frequency Sweep**.
- 2 In the **Settings** window for **Adaptive Frequency Sweep**, locate the **Study Settings** section.
- 3 In the **Frequencies** text field, type range (5.095 [MHz] , 0.2 [kHz] , 5.13 [MHz] ).
- 4 From the **AWE expression type** list, choose **User controlled**.
- 5 In the table, enter the following settings:

---

#### Asymptotic waveform evaluation (AWE) expressions

---

comp1.intop1(abs(comp1.u)/1e-9[m])

---

In the first study, disable the electrical circuit.

- 6 Locate the **Physics and Variables Selection** section. In the **Solve for** column of the table, under **Component 1 (comp1)**, clear the checkbox for **Electrical Circuit (cir)**.
- 7 In the **Study** toolbar, click  **Compute**.



## RESULTS

Instead of the stress plot, visualize the mode shape of the device at resonance.

### Displacement

- 1 In the **Model Builder** window, under **Results** click **Stress (solid)**.
- 2 In the **Settings** window for **3D Plot Group**, type Displacement in the **Label** text field.
- 3 Locate the **Data** section. From the **Parameter value (freq (Hz))** list, choose **5.112E6**.

### Volume 1

- 1 In the **Model Builder** window, expand the **Displacement** node, then click **Volume 1**.
- 2 In the **Settings** window for **Volume**, click **Replace Expression** in the upper-right corner of the **Expression** section. From the menu, choose **Component 1 (comp1) > Solid Mechanics > Displacement > solid.disp - Displacement magnitude - m**.
- 3 Locate the **Expression** section. From the **Unit** list, choose **nm**.
- 4 Click the  **Zoom Extents** button in the **Graphics** toolbar.
- 5 In the **Displacement** toolbar, click  **Plot**.

The second default plot shows the electric potential within the device. For a better view, plot 5 slices in  $xy$  planes.

### *Electric Potential (es)*

- 1 In the **Model Builder** window, under **Results** click **Electric Potential (es)**.
- 2 In the **Settings** window for **3D Plot Group**, locate the **Data** section.
- 3 From the **Parameter value (freq (Hz))** list, choose **5.112E6**.

### *Multislice 1*

- 1 In the **Model Builder** window, expand the **Electric Potential (es)** node, then click **Multislice 1**.
- 2 In the **Settings** window for **Multislice**, locate the **Multipane Data** section.
- 3 Find the **x-planes** subsection. From the **Entry method** list, choose **Number of planes**.
- 4 In the **Planes** text field, type 5.
- 5 Find the **y-planes** subsection. From the **Entry method** list, choose **Number of planes**.
- 6 In the **Planes** text field, type 0.
- 7 Find the **z-planes** subsection. From the **Entry method** list, choose **Number of planes**.
- 8 In the **Planes** text field, type 0.

### *Streamline Multislice 1*

- 1 In the **Model Builder** window, click **Streamline Multislice 1**.
- 2 In the **Settings** window for **Streamline Multislice**, locate the **Multipane Data** section.
- 3 Find the **x-planes** subsection. From the **Entry method** list, choose **Number of planes**.
- 4 In the **Planes** text field, type 5.
- 5 Find the **y-planes** subsection. From the **Entry method** list, choose **Number of planes**.
- 6 In the **Planes** text field, type 0.
- 7 Find the **z-planes** subsection. From the **Entry method** list, choose **Number of planes**.
- 8 In the **Planes** text field, type 0.
- 9 In the **Electric Potential (es)** toolbar, click  **Plot**.

Add a plot to show the mechanical response of the device.

### *Mechanical Response*

- 1 In the **Results** toolbar, click  **ID Plot Group**.
- 2 In the **Settings** window for **ID Plot Group**, type Mechanical Response in the **Label** text field.



### *Point Graph 1*

- 1 Right-click **Mechanical Response** and choose **Point Graph**.
- 2 Select Point 8 only.

- 3 In the **Settings** window for **Point Graph**, locate the **y-Axis Data** section.
- 4 In the **Expression** text field, type `abs(u)`.
- 5 From the **Unit** list, choose **nm**.
- 6 Locate the **x-Axis Data** section. From the **Unit** list, choose **MHz**.
- 7 In the **Mechanical Response** toolbar, click  **Plot**.

Now set up a study to compute the frequency response of the device with different capacitors added in series.

#### ADD STUDY

- 1 In the **Home** toolbar, click  **Add Study** to open the **Add Study** window.
- 2 Go to the **Add Study** window.
- 3 Find the **Studies** subsection. In the **Select Study** tree, select **Empty Study**.
- 4 Click the **Add Study** button in the window toolbar.
- 5 In the **Home** toolbar, click  **Add Study** to close the **Add Study** window.

#### STUDY 2

*Step 1: Adaptive Frequency Sweep*

- 1 In the **Study** toolbar, click  **More Study Steps** and choose **Frequency Domain** > **Adaptive Frequency Sweep**.
- 2 In the **Settings** window for **Adaptive Frequency Sweep**, locate the **Study Settings** section.
- 3 In the **Frequencies** text field, type `range(5.095[MHz], 0.2[kHz], 5.13[MHz])`.
- 4 From the **AWE expression type** list, choose **User controlled**.
- 5 In the table, enter the following settings:

---

##### Asymptotic waveform evaluation (AWE) expressions

---

```
comp1.intop1(abs(comp1.u)/1e-9[m])
```

---

- 6 Locate the **Physics and Variables Selection** section. Select the **Modify model configuration for study step** checkbox.
- 7 In the tree, select **Component 1 (comp1)** > **Electrostatics (es)** > **Boundary Terminal 2**.
- 8 Click  **Disable**.

To reduce file size, only store solution data on the external surfaces.

9 Click to expand the **Store in Output** section. In the table, enter the following settings:

| Interface               | Output    |
|-------------------------|-----------|
| Solid Mechanics (solid) | Selection |

10 Under **Selections**, click **+ Add**.

11 In the **Add** dialog, select **All surfaces** in the **Selections** list.

12 Click **OK**.

13 In the **Settings** window for **Adaptive Frequency Sweep**, locate the **Store in Output** section.

14 In the table, enter the following settings:

| Interface           | Output    |
|---------------------|-----------|
| Electrostatics (es) | Selection |

15 Under **Selections**, click **+ Add**.

16 In the **Add** dialog, select **All surfaces** in the **Selections** list.

17 Click **OK**.

#### *Parametric Sweep*

1 In the **Study** toolbar, click  **Parametric Sweep**.

2 In the **Settings** window for **Parametric Sweep**, locate the **Study Settings** section.

3 Click **+ Add**.

4 In the table, enter the following settings:

| Parameter name          | Parameter value list | Parameter unit |
|-------------------------|----------------------|----------------|
| Cs (Series capacitance) | 0.1 0.4 1            | pF             |

5 In the **Model Builder** window, click **Study 2**.

6 In the **Settings** window for **Study**, locate the **Study Settings** section.

7 Clear the **Generate default plots** checkbox.

8 In the **Study** toolbar, click  **Compute**.

## **RESULTS**

Replot the mechanical response with the additional series capacitance.

#### *Mechanical response, Parametric*

1 In the **Model Builder** window, right-click **Mechanical Response** and choose **Duplicate**.

- 2 In the **Settings** window for **ID Plot Group**, type Mechanical response, Parametric in the **Label** text field.
- 3 Locate the **Data** section. From the **Dataset** list, choose **Study 2/ Parametric Solutions 1 (sol3)**.
- 4 Locate the **Legend** section. From the **Position** list, choose **Upper left**.

#### *Point Graph 1*

- 1 In the **Model Builder** window, expand the **Mechanical response, Parametric** node, then click **Point Graph 1**.
- 2 In the **Settings** window for **Point Graph**, click to expand the **Legends** section.
- 3 Select the **Show legends** checkbox.
- 4 In the **Mechanical response, Parametric** toolbar, click  **Plot**.  
Note how the mechanical resonant frequency is 'pulled' by the series capacitance.